

MGA-634P8

Ultra Low Noise, High Linearity Low Noise Amplifier



Data Sheet



Description

Avago Technologies' MGA-634P8 is an economical, easy-to-use GaAs MMIC Low Noise Amplifier (LNA). The LNA has low noise and high linearity achieved through the use of Avago Technologies' proprietary 0.25um GaAs Enhancement-mode pHEMT process. It is housed in a miniature 2.0 x 2.0 x 0.75mm³ 8-pin Quad-Flat-Non-Lead (QFN) package. It is designed for optimum use from 1.5 GHz up to 2.3 GHz. The compact footprint and low profile coupled with low noise, high gain and high linearity make the MGA-634P8 an ideal choice as a low noise amplifier for cellular infrastructure for GSM and CDMA. For optimum performance at lower frequency from 450MHz up to 1.5GHz, MGA-633P8 is recommended. For optimum performance at higher frequency from 2.3GHz up to 4GHz, MGA-635P8 is recommended. All these 3 products, MGA-633P8, MGA-634P8 and MGA-635P8 share the same package and pinout configuration.

Pin Configuration and Package Marking

2.0 x 2.0 x 0.75 mm³ 8-lead QFN

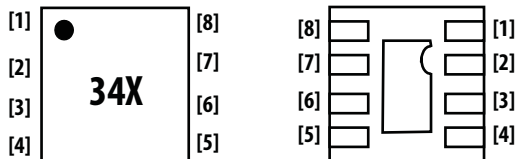

Top View

- Pin 1 - Vbias
- Pin 2 - RFinput
- Pin 3 - Not Used
- Pin 4 - Not Used

Bottom View

- Pin 5 - Not Used
- Pin 6 - Not Used
- Pin 7 - RFoutput/Vdd
- Pin 8 - Not Used
- Centre tab - Ground

Note:

Package marking provides orientation and identification
"34" = Device Code, where X is the month code.



Attention: Observe precautions for handling electrostatic sensitive devices.

ESD Machine Model = 70 V (Class A)
ESD Human Body Model = 500 V (Class 1B)
Refer to Avago Application Note A004R:
Electrostatic Discharge, Damage and Control.

Features

- Ultra Low noise Figure
- High linearity performance
- GaAs E-pHEMT Technology [1]
- Low cost small package size: 2.0x2.0x0.75 mm³
- Excellent uniformity in product specifications
- Tape-and-Reel packaging option available

Specifications

1.9 GHz; 5V, 48mA

- 17.4 dB Gain
- 0.44 dB Noise Figure
- 15.5 dB Input Return Loss
- 36 dBm Output IP3
- 21 dBm Output Power at 1dB gain compression

Applications

- Low noise amplifier for cellular infrastructure for GSM TDS-CDMA, and CDMA.
- Other ultra low noise application.

Simplified Schematic

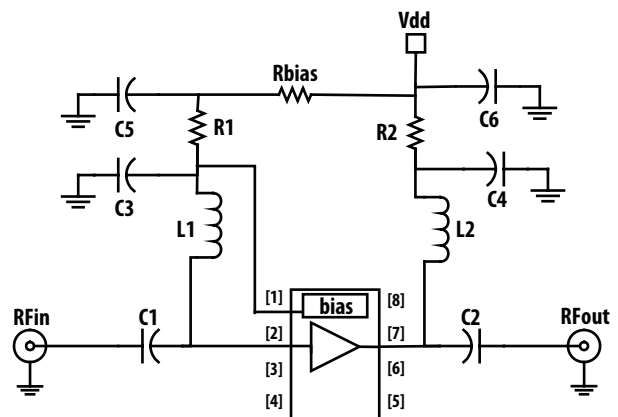

Notes:

- The schematic is shown with the assumption that similar PCB is used for all MGA-633P8, MGA-634P8 and MGA-635P8.
- Detail of the components needed for this product is shown in Table 1.
- Enhancement mode technology employs positive gate voltage, thereby eliminating the need of negative gate voltage associated with conventional depletion mode devices.
- Good RF practice requires all unused pins to be earthed.

Absolute Maximum Rating ^[1] T_A=25°C

Symbol	Parameter	Units	Absolute Maximum
V _{dd}	Device Voltage, RF output to ground	V	5.5
V _{bias}	Gate Voltage	V	0.7
P _{in,max}	CW RF Input Power (V _{dd} = 5.0V, I _d = 50 mA)	dBm	+20
P _{diss}	Total Power Dissipation ^[2]	W	0.5
T _j	Junction Temperature	°C	150
T _{stg}	Storage Temperature	°C	-65 to 150

Thermal Resistance

Thermal Resistance ^[3]
(V_{dd} = 5.0V, I_{dd} = 50mA)
θ_{jc} = 62°C/W

Notes:

1. Operation of this device in excess of any of these limits may cause permanent damage.
2. Power dissipation with device turned on. Board temperature T_B is 25°C. Derate at 16mW/°C for T_B>119°C.
3. Thermal resistance measured using Infra-Red Measurement Technique

Electrical Specifications ^{[1], [4]}

RF performance at T_A = 25°C, V_{dd} = 5V, R_{bias} = 5.6 kOhm, 1.9 GHz, measured on demo board in Figure 1 with component listed in Table 1 for 1.9 GHz matching.

Symbol	Parameter and Test Condition	Units	Min.	Typ.	Max.
I _{dd}	Drain Current	mA	37	48	61
Gain	Gain	dB	16.1	17.4	19.1
OIP3 ^[2]	Output Third Order Intercept Point	dBm	33	36	
NF ^[3]	Noise Figure	dB		0.44	0.69
OP1dB	Output Power at 1dB Gain Compression	dBm		21	
IRL	Input Return Loss, 50Ω source	dB		15.5	
ORL	Output Return Loss, 50Ω load	dB		13	
REV ISOL	Reverse Isolation	dB		30	

Notes:

1. Measurements at 1.9 GHz obtained using demo board described in Figure 1.
2. OIP3 test condition: F_{RF1} = 1.9 GHz, F_{RF2} = 1.901 GHz with input power of -10dBm per tone.
3. For NF data, board losses of the input have not been de-embedded.
4. Use proper bias, heatsink and derating to ensure maximum device temperature is not exceeded. See absolute maximum ratings and application note for more details.

Product Consistency Distribution Charts [1, 2]

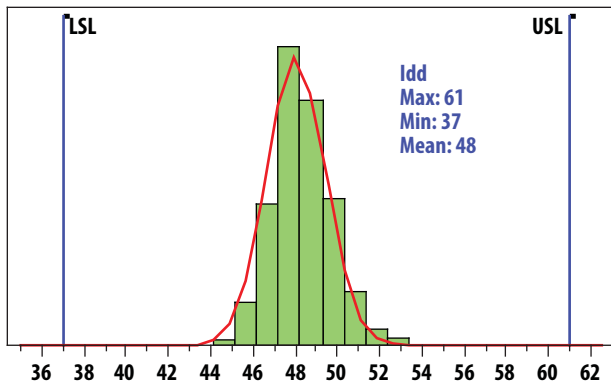

Figure 1. Idd @ 1.9GHz, 5V, 48mA Mean = 48

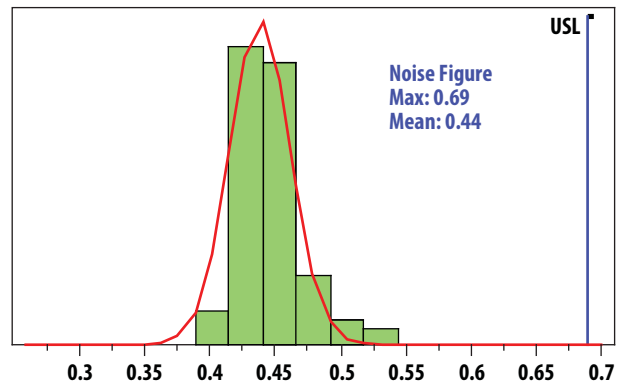

Figure 2. Noise Figure @1.9GHz, 5V, 48mA Mean = 0.44

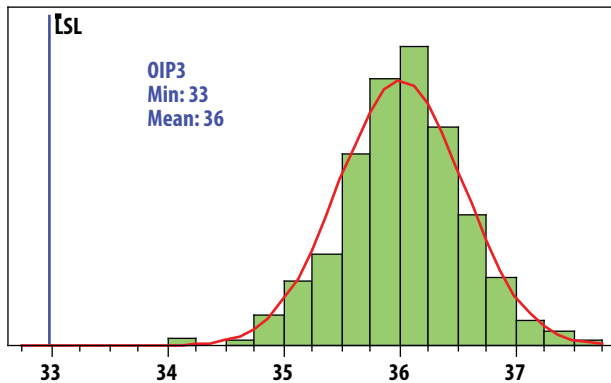

Figure 3. OIP3 @ 1.9GHz, 5V, 48mA Mean = 36

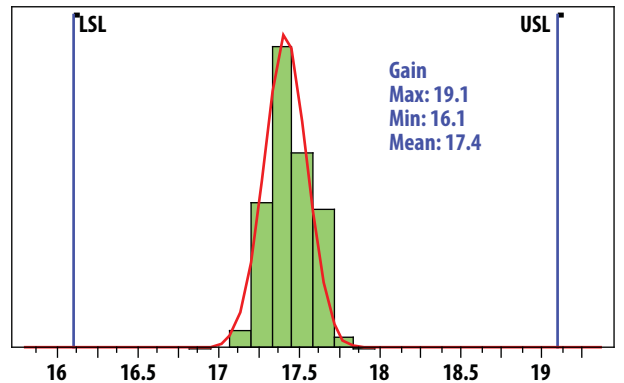

Figure 4. Gain @1.9GHz, 5V, 48mA Mean = 17.4

Notes:

1. Distribution data samples are 500 samples taken from 3 different wafers. Future wafers allocated to this product may have nominal values anywhere between the upper and lower limits.
2. Circuit Losses have not been de-embedded from the actual measurements.

Demo Board Layout

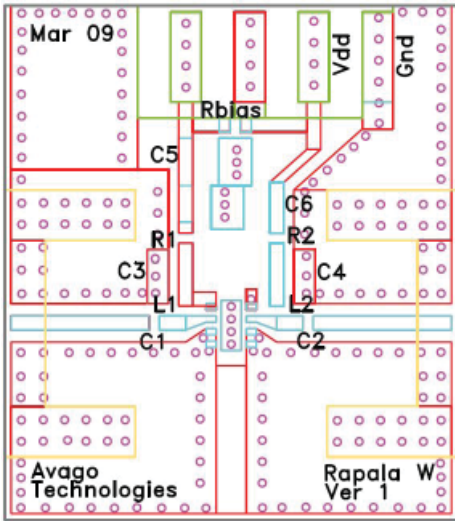

Figure 5. Demo Board Layout Diagram

- Recommended PCB material is 10 mils Rogers R04350.
- Suggested component values may vary according to layout and PCB material.

Demo Board Schematic

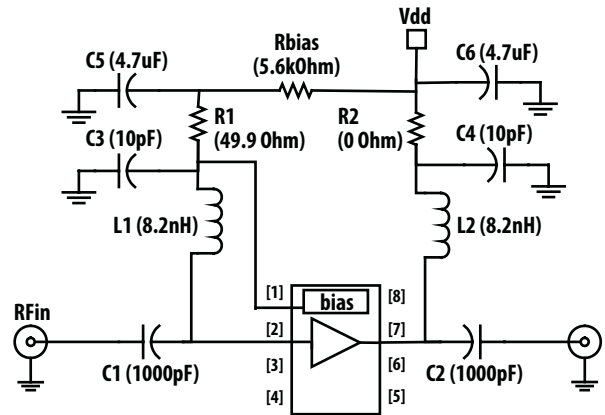

Figure 6. Demo Board Schematic Diagram

Table 1. Component list for 1.9 GHz matching

Part	Size	Value	Detail Part Number
C1, C2	0402	1000pF (Murata)	GRM155R71H102KA01E
L1	0402	8.2nH (CoilCraft)	0402CS-8N2XGLU
L2	0402	8.2nH (Toko)	LLP1005-FH8N2C
C3, C4	0402	10pF (Murata)	GRM1555C1H100JZ01E
C5, C6	0805	4.7uF (Murata)	GRM21BR60J475KA11L
R1	0402	49.9 Ohm (Rohm)	MCR01 MZS F 49R9
R2	0402	0 Ohm (Kamaya)	RMC1/16S-JPTH
Rbias	0402	5.6 kohm (Rohm)	MCR01 MZS J 562

Note:

- C1, C2 are DC Blocking capacitors
- L1 input match for NF
- L2 output match for OIP3
- C3, C4, C5, C6 are bypass capacitors
- R1 is stabilizing resistor
- Rbias is the biasing resistor

MGA-634P8 Typical Performance

RF performance at $T_A = 25^\circ\text{C}$, $V_{dd} = 5\text{V}$, $I_d = 50\text{mA}$, measured using 50ohm input and output board, unless otherwise stated. OIP3 test condition: $F_{RF1} = 1.9\text{GHz}$, $F_{RF2} = 1.901\text{GHz}$ with input power of -10dBm per tone.

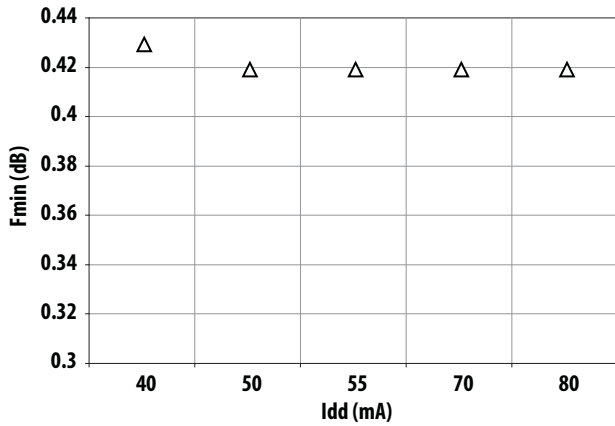

Figure 7. Fmin vs Idd at 5V at 1.9GHz.

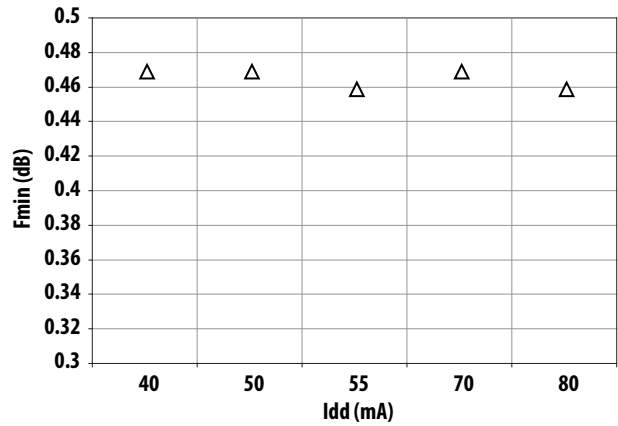

Figure 8. Fmin vs Idd at 5V at 2GHz.

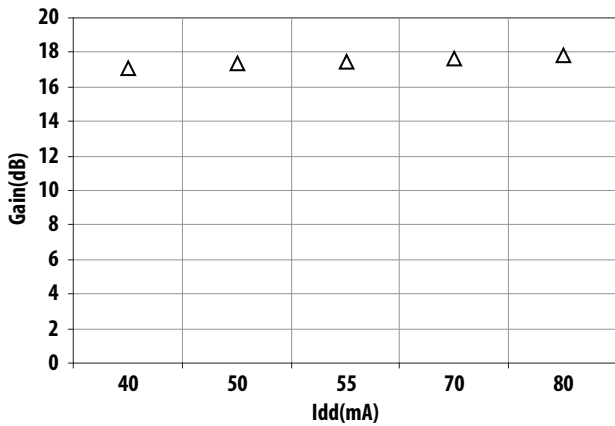

Figure 9. Gain vs Idd at 5V Tuned for Optimum OIP3 and Fmin at 1.9GHz.

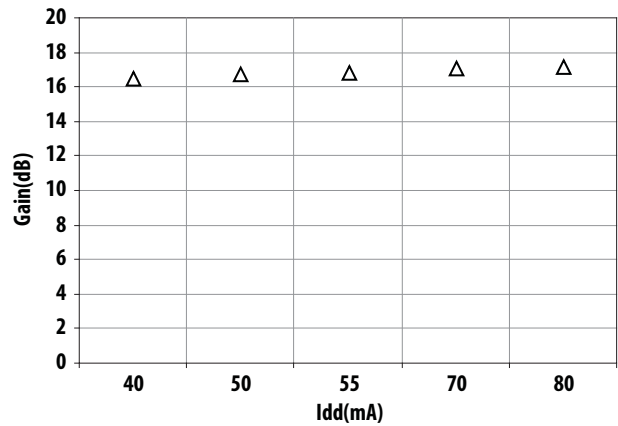

Figure 10. Gain vs Idd at 5V Tuned for Optimum OIP3 and Fmin at 2GHz.

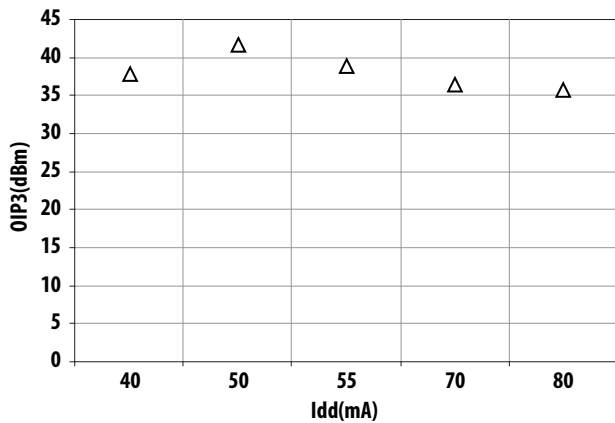

Figure 11. OIP3 vs Idd at 5V Tuned for Optimum OIP3 and Fmin at 1.9GHz.

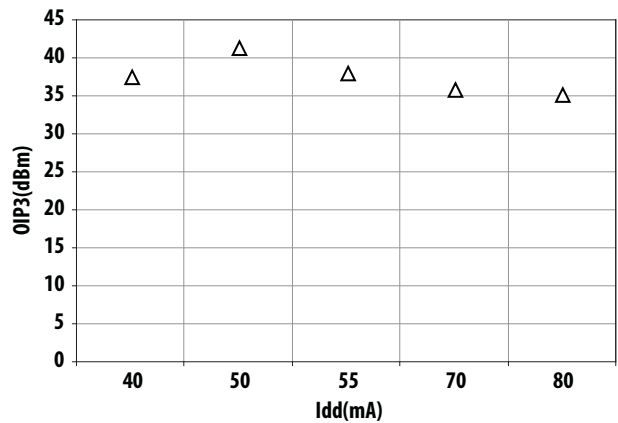

Figure 12. OIP3 vs Idd at 5V Tuned for Optimum OIP3 and Fmin at 2GHz.

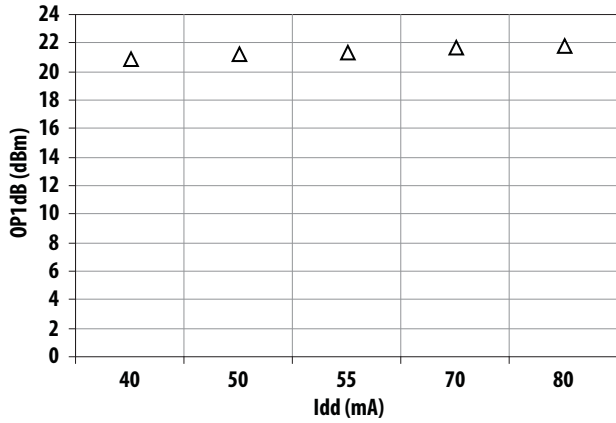

Figure 13. OP1dB vs Idd at 5V Tuned for Optimum OIP3 and Fmin at 1.9GHz

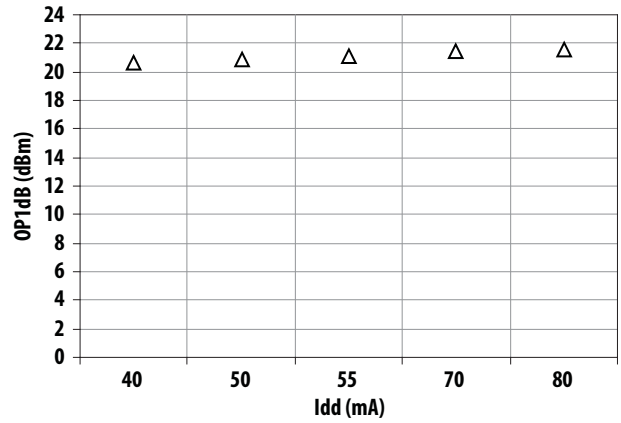

Figure 14. OP1dB vs Idd at 5V Tuned for Optimum OIP3 and Fmin at 2GHz.

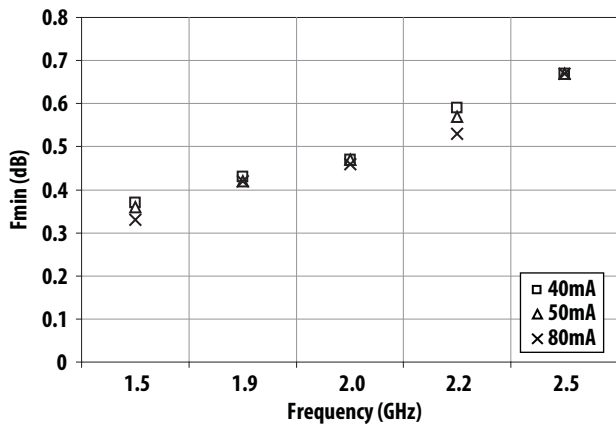

Figure 15. Fmin vs Frequency and Idd at 5V

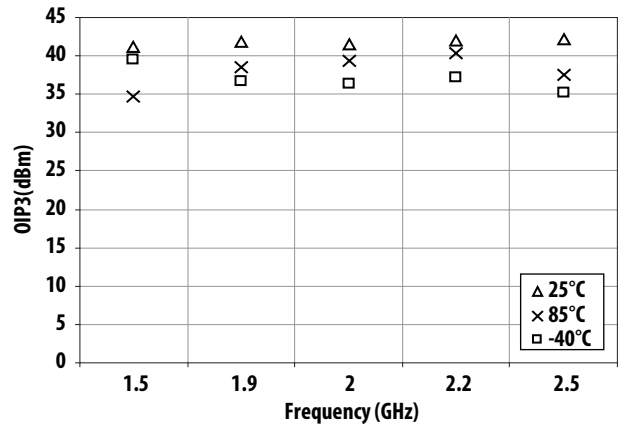

Figure 16. OIP3 vs Frequency and Temperature for Optimum OIP3 and Fmin at 5V 50mA

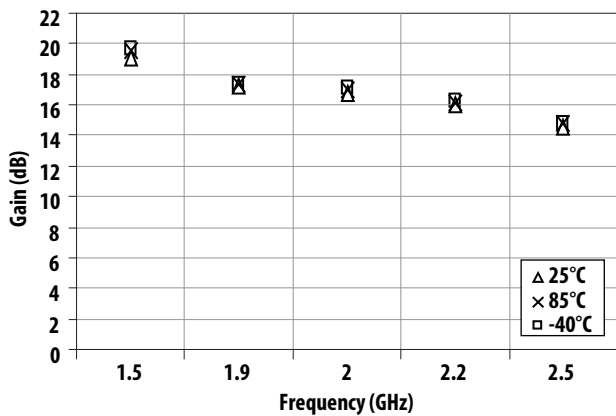

Figure 17. Gain vs Frequency and Temperature for Optimum OIP3 and Fmin at 5V 50mA

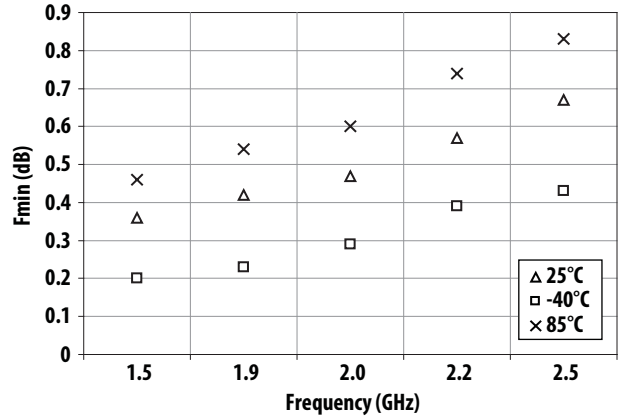

Figure 18. Fmin vs Frequency and Temperature for Optimum OIP3 and Fmin at 5V 50mA

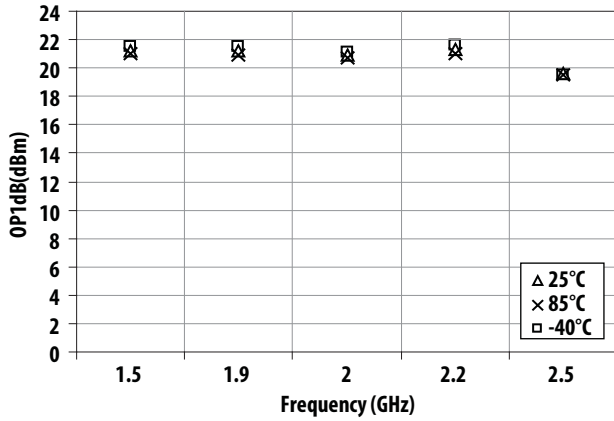
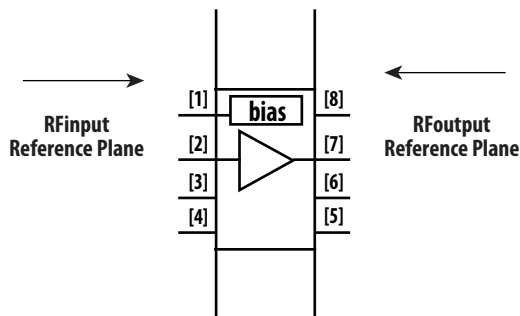

Figure 19. OP1dB vs Frequency and Temperature for Optimum OIP3 and Fmin at 5V 50mA

Below is the table showing the MGA-634P8 Reflection Coefficient Parameters tuned for maximum OIP3, Vdd = 5V, Idd = 50mA

Frequency (GHz)	Gamma Load position		OIP3 (dBm)	OP1dB (dBm)
	Magnitude	Angle		
1.5	0.42	20	41.13	21.26
1.9	0.28	30	41.8	21.19
2	0.28	30	41.56	20.89
2.2	0.42	40.1	41.95	21.36
2.5	0.57	57.6	42.24	19.65



Notes:

1. The maximum OIP3 values are calculated based on Load pull measurements on approximately 136 different impedances using Focus' Load Pull test system.
2. Measurements are conducted on 0.010 inch thick ROGER 4350. The input reference plane is at the end of the RFin pin and the output reference plane is at the end of the RFout pin as shown in Figure 20.
3. Gamma Load for maximum OIP3 with biasing of 5V 40mA, 5V 50mA, 5V 70mA and 5V 80mA from 1.5GHz to 2.5GHz are available upon request.

Figure 20

MGA-634P8 Typical Performance in Demoboard

RF performance at $T_A = 25^\circ\text{C}$, $V_{dd} = 5\text{V}$, $R_{bias} = 5.6\text{ k}\Omega$, measured on demo board in Figure. 5 with component list in Table 1 for 1.9 GHz matching, unless or otherwise stated.

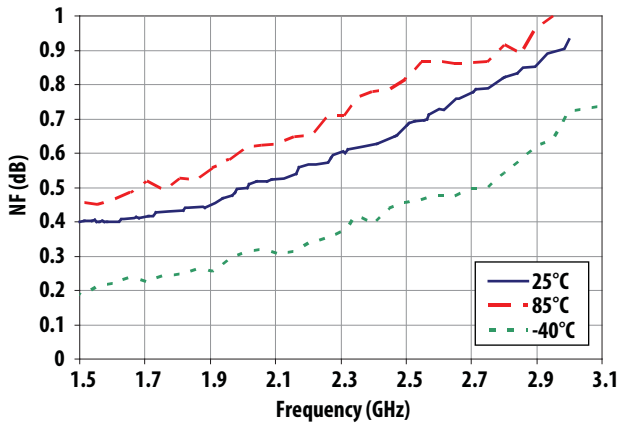

Figure 21. NF vs Frequency vs Temperature

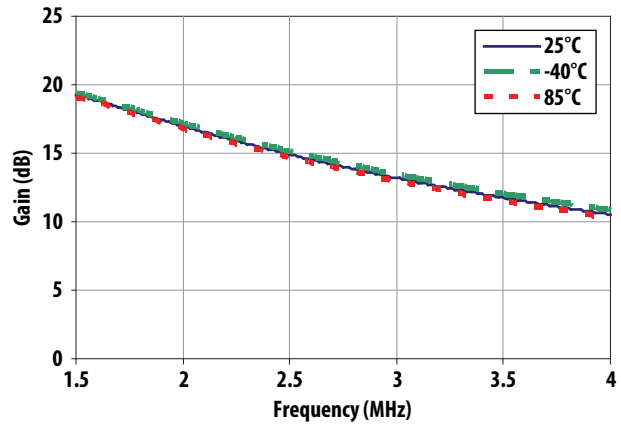

Figure 22. Gain vs Frequency vs Temperature

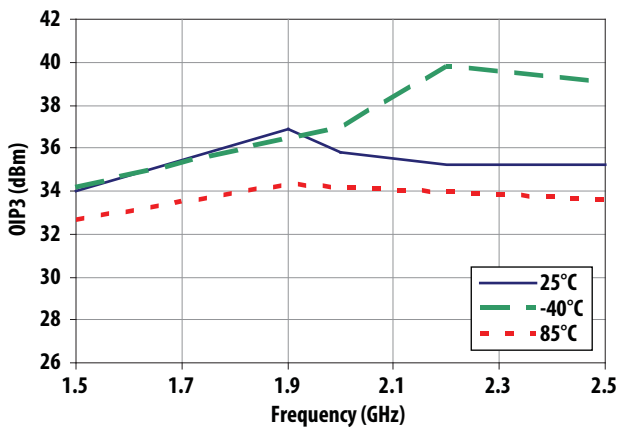

Figure 23. OIP3 vs Frequency vs Temperature

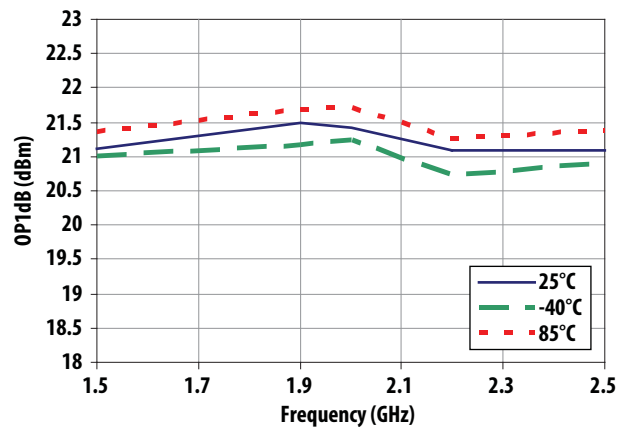

Figure 24. OP1dB vs Frequency vs Temperature

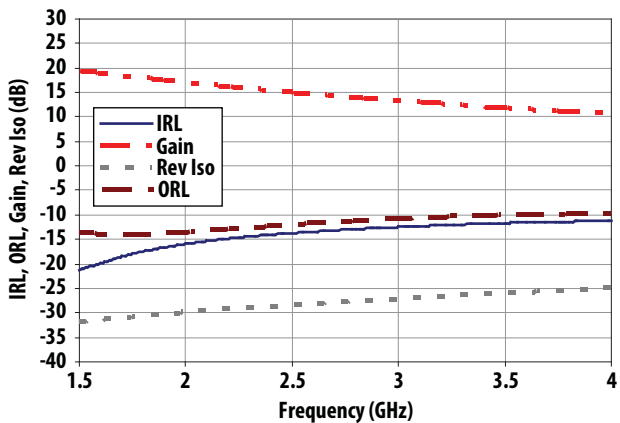

Figure 25. S-Parameter performance with DUT on demoboard shown in Figure 1.

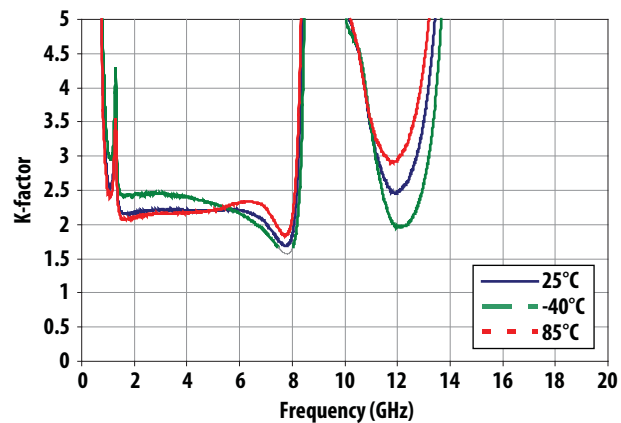

Figure 26. K-factor vs Frequency vs Temperature

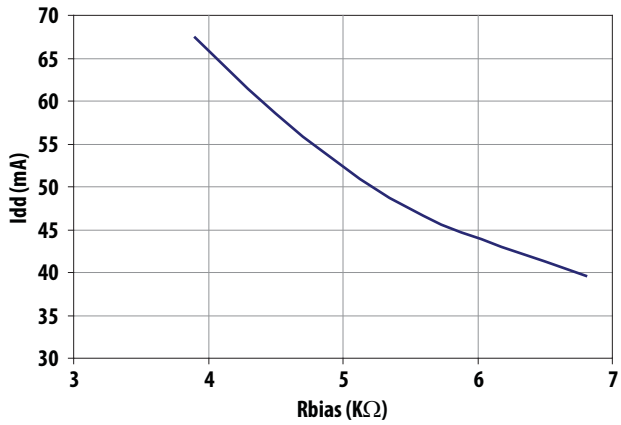

Figure 27. I_{dd} vs R_{bias}

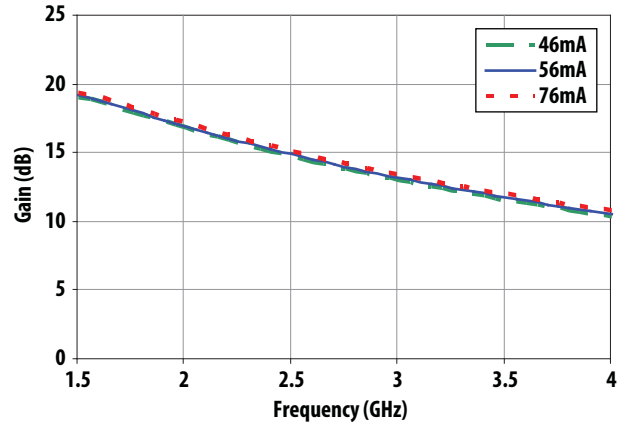

Figure 28. Gain vs Frequency vs I_{dd}

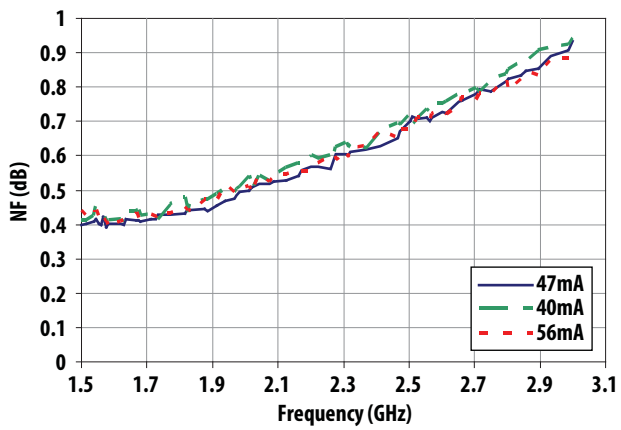

Figure 29. NF vs Frequency vs I_{dd}

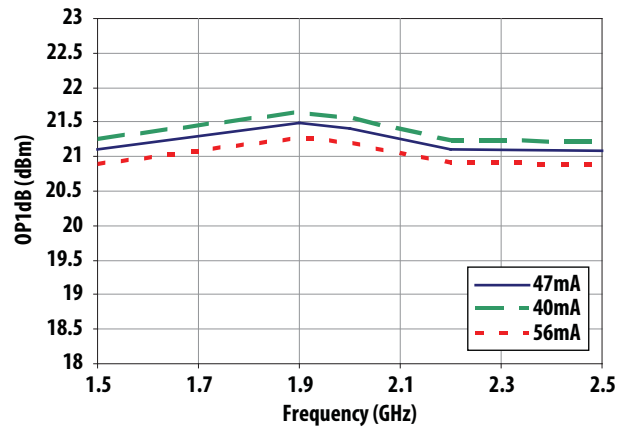

Figure 30. OP1dB vs Frequency vs I_{dd}

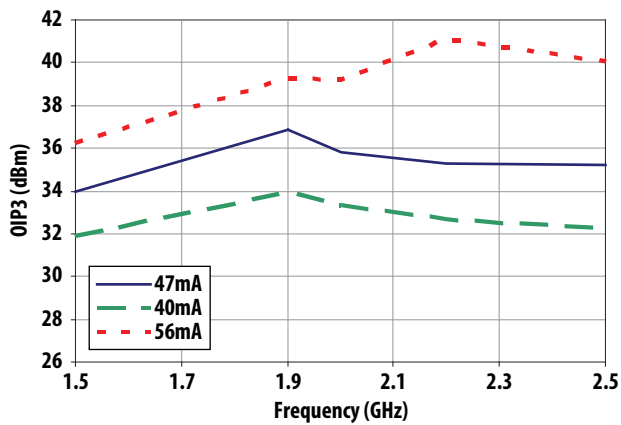

Figure 31. OIP3 vs Frequency vs I_{dd}

MGA-634P8 Typical Scattering Parameters, Vdd = 5V, Idd = 50mA

Freq GHz	S11		S21			S12		S22	
	Mag.	Ang.	dB	Mag.	Ang.	Mag.	Ang.	Mag.	Ang.
0.10	0.23	-163.34	8.19	2.57	-125.30	0.00	97.65	0.94	160.95
0.50	0.48	136.70	14.45	5.28	171.68	0.00	79.05	0.72	85.19
0.90	0.37	37.53	21.26	11.56	113.46	0.01	84.82	0.45	1.93
1.00	0.27	9.09	21.61	12.04	88.15	0.01	66.43	0.36	-25.00
1.50	0.09	-176.43	19.22	9.14	18.04	0.03	7.89	0.21	-60.82
1.90	0.15	115.81	17.45	7.46	-34.36	0.03	-34.00	0.20	-142.05
2.00	0.16	104.04	16.94	7.03	-47.24	0.03	-43.61	0.21	-158.67
2.50	0.21	62.05	14.92	5.57	-98.96	0.04	-84.48	0.25	141.36
3.00	0.24	24.06	13.16	4.55	-149.45	0.04	-124.96	0.29	89.94
4.00	0.28	-49.44	10.50	3.35	116.58	0.06	158.36	0.33	-3.50
5.00	0.29	-130.59	8.39	2.63	23.57	0.07	80.99	0.35	-103.34
6.00	0.32	142.80	6.26	2.06	-69.38	0.08	2.65	0.40	155.89
7.00	0.41	59.02	4.36	1.65	-162.15	0.09	-76.09	0.45	64.58
8.00	0.61	-25.71	2.84	1.39	83.27	0.12	-177.50	0.20	-45.85
9.00	0.55	-99.89	-12.65	0.23	40.36	0.03	146.66	0.60	-19.43
10.00	0.64	-158.49	-7.75	0.41	-26.75	0.07	92.57	0.69	-105.31
11.00	0.67	143.37	-8.52	0.38	-104.19	0.09	25.31	0.74	-173.97
12.00	0.62	84.82	-8.10	0.39	174.66	0.12	-48.61	0.76	113.83
13.00	0.40	10.64	-7.36	0.43	74.90	0.18	-140.59	0.61	25.16
14.00	0.17	168.38	-10.64	0.29	-46.45	0.14	97.06	0.25	-116.58
15.00	0.20	114.45	-18.47	0.12	-121.86	0.10	56.12	0.22	117.87
16.00	0.62	53.59	-21.00	0.09	151.34	0.08	-60.50	0.51	83.13
17.00	0.74	3.66	-24.22	0.06	84.71	0.04	-159.91	0.59	31.81
18.00	0.73	-35.67	-26.17	0.05	5.69	0.01	145.48	0.69	-11.95
19.00	0.69	-73.02	-28.94	0.04	-56.84	0.02	92.22	0.66	-58.62
20.00	0.61	-109.61	-34.21	0.02	-123.92	0.04	31.07	0.50	-104.19

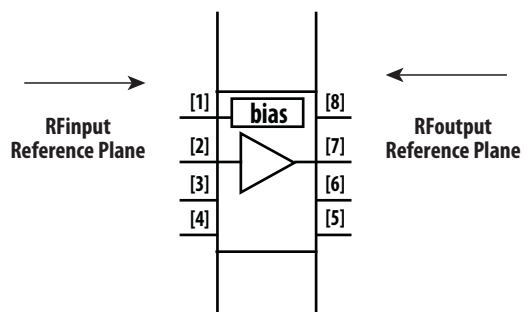

Figure 32.

Typical Noise Parameters, Vdd = 5V, Idd = 50mA

Freq GHz	Fmin dB	Γ_{opt} Mag.	Γ_{opt} Ang.	$R_{n/50}$
1.5	0.36	0.138	68.4	0.0484
1.9	0.42	0.191	113.6	0.0442
2	0.47	0.177	120.4	0.0526
2.2	0.57	0.173	131.1	0.0444
2.5	0.67	0.188	151.5	0.0476

Notes:

1. The Fmin values are based on noise figure measurements at 100 different impedances using Focus source pull test system. From these measurements a true Fmin is calculated.
2. Scattering and noise parameters are measured on coplanar waveguide made on 0.010 inch thick ROGER 4350. The input reference plane is at the end of the RFinpin and the output reference plane is at the end of the RFoutput pin as shown in figure 32.
3. S2P file with scattering and noise parameters for biasing 5V 40mA, 5V 50mA, 5V 70mA and 5V 80mA are available upon request.

Part Number Ordering Information

Part Number	No. of Devices	Container
MGA-634P8-BLKG	100	Antistatic Bag
MGA-634P8-TR1G	3000	7 inch Reel

SLP2X2 Package

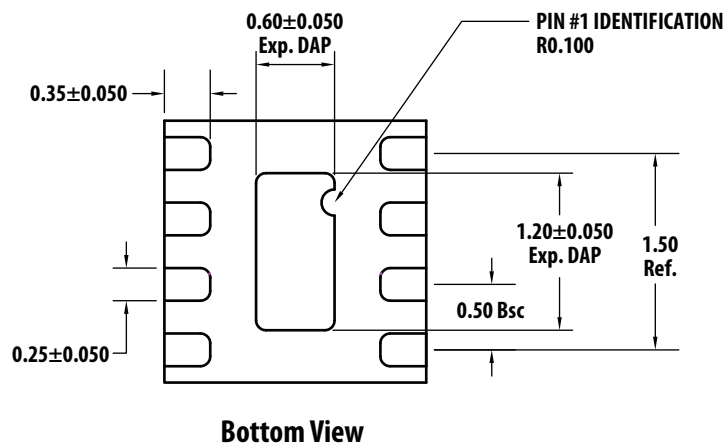
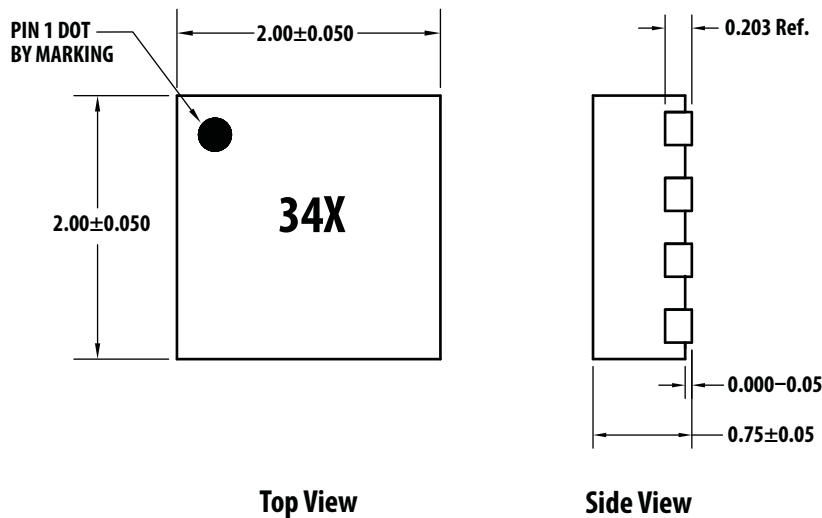

Notes:

1. All dimensions are in millimeters.
2. Dimensions are inclusive of plating.
3. Dimensions are exclusive of mold flash and metal burr.

Recommended PCB Land Pattern and Stencil Design

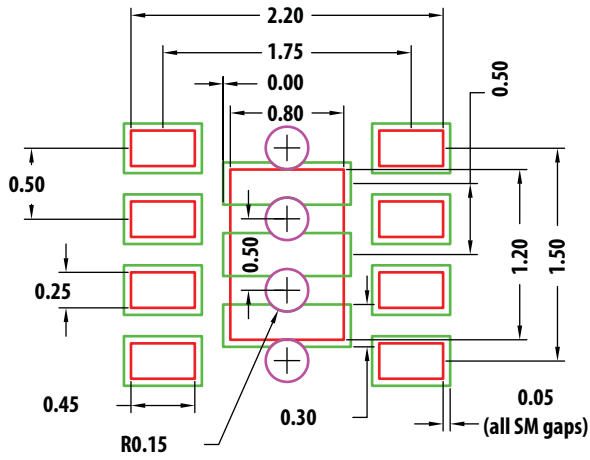

Land Pattern

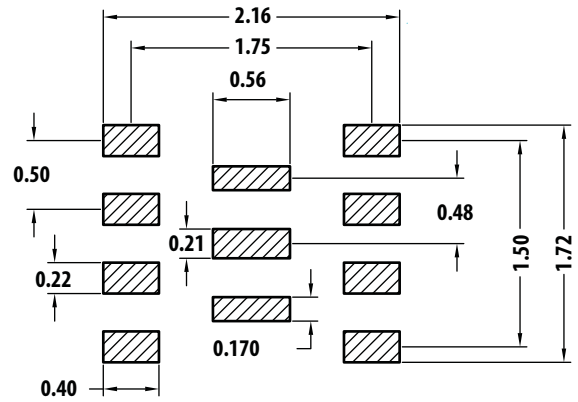

Stencil Opening

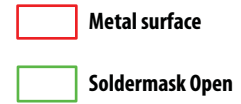
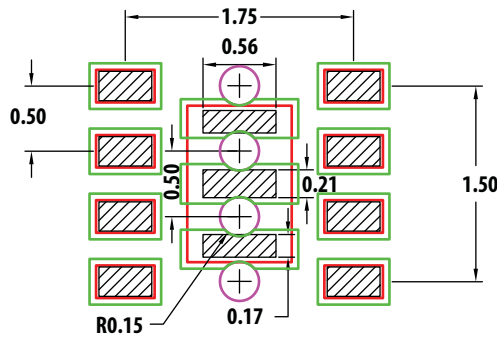

Combination of Land Pattern and Stencil Opening

Note:

1. Recommended Land Pattern and Stencil Opening
2. Stencil thickness is 0.1mm (4 mils)
3. All dimension are in mm unless otherwise specified

Device Orientation

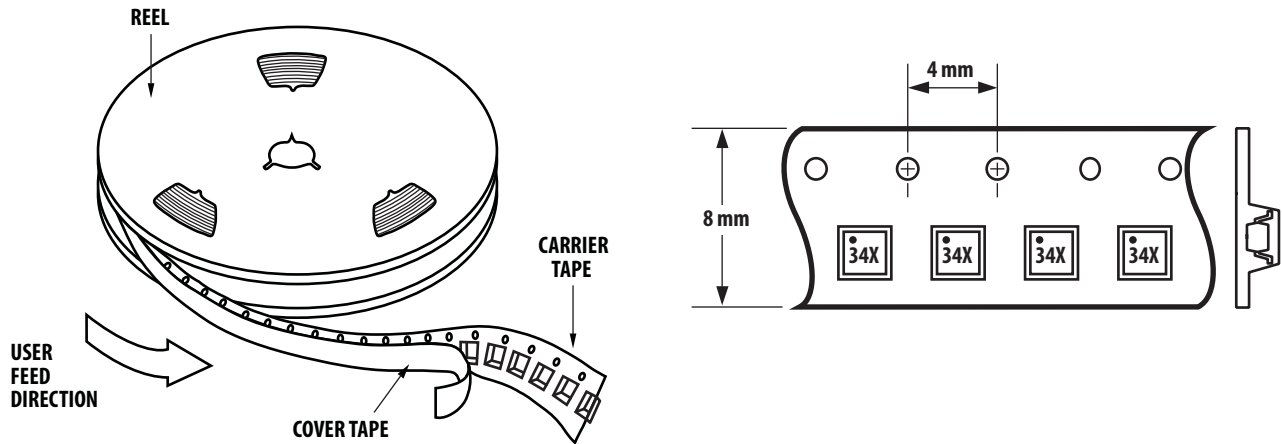

Tape Dimensions

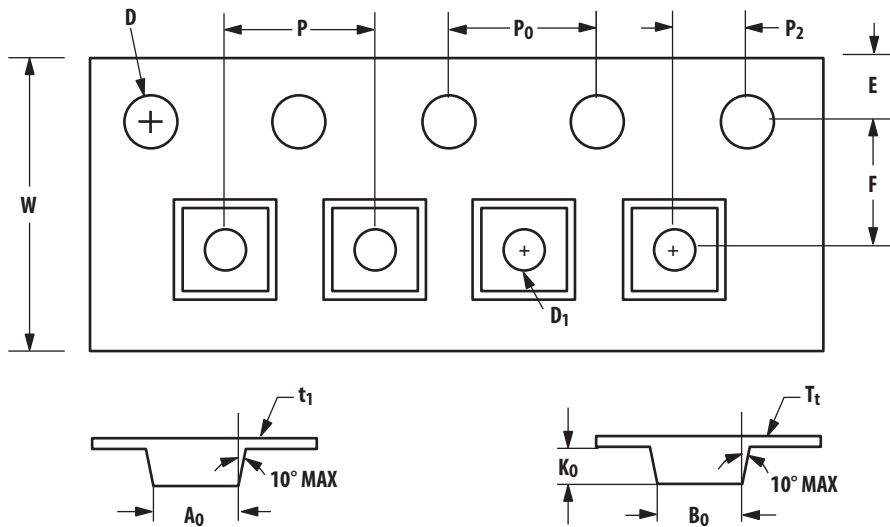

	DESCRIPTION	SYMBOL	SIZE (mm)	SIZE (INCHES)
CAVITY	LENGTH	A_0	2.30 ± 0.05	0.094 ± 0.004
	WIDTH	B_0	2.30 ± 0.05	0.094 ± 0.004
	DEPTH	K_0	1.00 ± 0.05	0.047 ± 0.004
	PITCH	P	4.00 ± 0.10	0.157 ± 0.004
	BOTTOM HOLE DIAMETER	D_1	1.00 ± 0.25	0.039 ± 0.010
PERFORATION	DIAMETER	D	1.50 ± 0.10	0.061 ± 0.002
	PITCH	P_0	4.00 ± 0.10	0.157 ± 0.004
	POSITION	E	1.75 ± 0.10	0.069 ± 0.004
CARRIER TAPE	WIDTH	W	8.00 ± 0.30	0.315 ± 0.012
	THICKNESS	t_1	8.00 ± 0.10 0.254 ± 0.02	0.315 ± 0.004 0.0100 ± 0.0008
COVER TAPE	WIDTH	C	5.4 ± 0.10	0.205 ± 0.004
	TAPE THICKNESS	T_t	0.062 ± 0.001	0.0025 ± 0.0004
DISTANCE	CAVITY TO PERFORATION (WIDTH DIRECTION)	F	3.50 ± 0.05	0.138 ± 0.002
	CAVITY TO PERFORATION (LENGTH DIRECTION)	P_2	2.00 ± 0.05	0.079 ± 0.002

Reel Dimensions – 7 inch

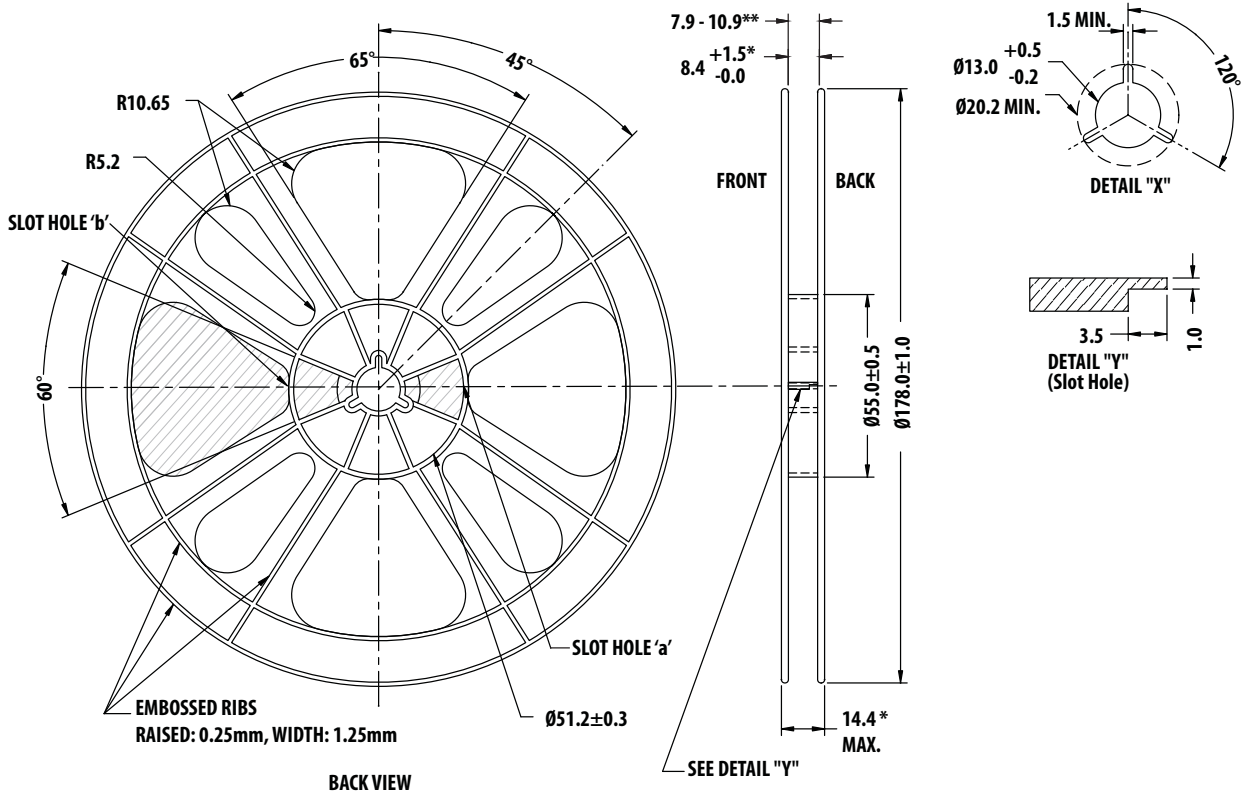
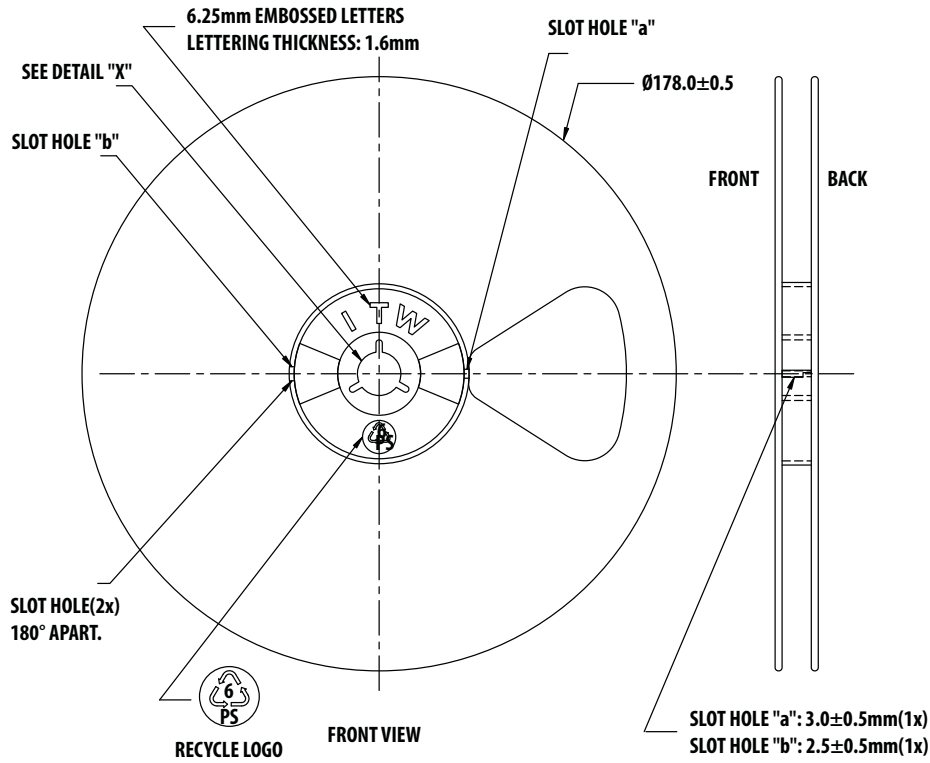

For product information and a complete list of distributors, please go to our web site: www.avagotech.com

Avago, Avago Technologies, and the A logo are trademarks of Avago Technologies in the United States and other countries. Data subject to change. Copyright © 2005-2012 Avago Technologies. All rights reserved. AV02-2544EN - May 25, 2012