

# MC33560

## Power Management and Interface IC for Smartcard Readers and Couplers

The MC33560 is an interface IC for smartcard reader/writer applications. It enables the management of any type of smart or memory card through a simple and flexible microcontroller interface. Moreover, several couplers can be coupled in parallel, thanks to the chip select input pin (Pin 5). The MC33560 is particularly suited to low power and portable applications because of its power saving features and the minimum of external parts required. Battery life is extended by the wide operating range and the low quiescent current in standby mode. A highly sophisticated protection system guarantees timely and controlled shutdown upon error conditions.

- 100% Compatible with ISO 7816–3 Standard
- Wide Battery Supply Voltage Range:  $1.8\text{ V} < V_{\text{BAT}} < 6.6\text{ V}$
- Programmable  $V_{\text{CC}}$  Supply for 3.0 V or 5.0 V Card Operation
- Power Management for Very Low Quiescent Current in Standby Mode (30  $\mu\text{A}$  max)
- Microprocessor Wakeup Signal Generated Upon Card Insertion
- Self Contained DC–DC Converter to Generate  $V_{\text{CC}}$  using a Minimum of Passive Components
- Controlled Powerup/Down Sequence for High Signal Integrity on the Card I/O and Signal Lines
- Programmable Card Clock Generator
- Chip Select Capability for Parallel Coupler Operation
- High ESD Protection on Card Pins (4.0 kV, Human Body Model)
- Fault Monitoring  $V_{\text{BATlow}}$ ,  $V_{\text{CClow}}$  and  $I_{\text{CClim}}$
- All Card Outputs Current Limited and Short Circuit Protected
- Tested Operating Temperature Range:  $-25^{\circ}\text{C}$  to  $+85^{\circ}\text{C}$
- Pb–Free Packages are Available



**ON Semiconductor®**

<http://onsemi.com>



**SO–24W  
DW SUFFIX  
CASE 751E**

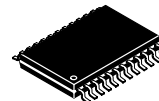

**TSSOP–24  
DTB SUFFIX  
CASE 948K**

### MARKING DIAGRAMS

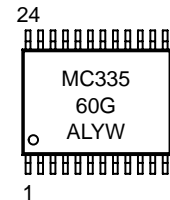
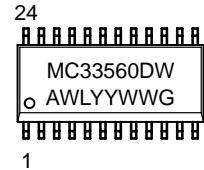

A = Assembly Location  
 WL, L = Wafer Lot  
 YY, Y = Year  
 WW, W = Work Week  
 G = Pb–Free Device

### PIN CONNECTIONS

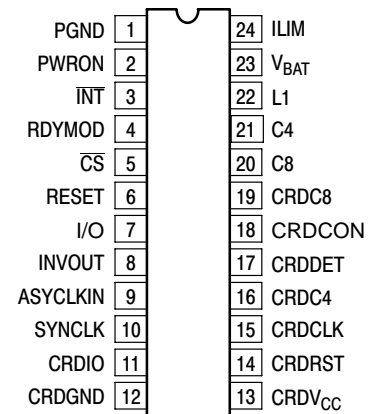

(Top View)

### ORDERING INFORMATION

See detailed ordering and shipping information in the package dimensions section on page 24 of this data sheet.

# MC33560

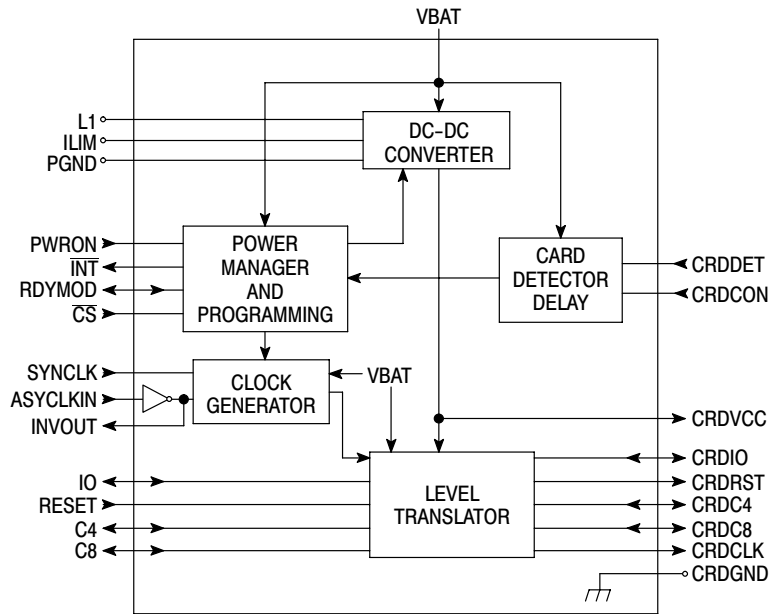

Figure 1. Simplified Functional Block Diagram

## MAXIMUM RATINGS (Note 1)

Symbol	Rating	Value	Unit
$V_{BAT}$	Battery Supply Voltage	7.0	V
$I_{BAT}$	Battery Supply Current	$\pm 200$	mA
$V_{CC}$	Power Supply Voltage	6.0	V
$I_{CC}$	Power Supply Current	$\pm 150$	mA
$V_{IN}$ $I_{IN}$	Digital Input Pins 2, 4, 5, 6, 7, 9, 10, 17, 18, 20, 21	$-0.5$ to $V_{BAT} + 0.5$ but $< 7.0$ $\pm 5.0$	V mA
$V_{OUT}$ $I_{OUT}$	Digital Output Pins 3, 4, 8	$-0.5$ to $V_{BAT} + 0.5$ but $< 7.0$ $\pm 10$	V mA
$V_{Card}$ $I_{Card}$	Card Interface Pins 11, 13, 14, 15, 16, 19	$-0.5$ to $V_{CC} + 0.5$ $\pm 25$	V mA
$I_L$	Coil Driver Pin 22, ILIM (Pin 24) Power Ground (Pin 1)	$\pm 200$ $\pm 100$	mA
$V_{ESD}$	ESD Capability: (Note 2) Standard Pins 2, 3, 4, 5, 6, 7, 8, 9, 10, 17, 18, 20, 21, 22, 23, 24 Card Interface Pins 11, 13, 14, 15, 16, 19	2.0 4.0	kV kV
$P_{Ds}$ $R_{\theta JA s}$	SO-24 Package: Power Dissipation @ $T_A = 85^\circ\text{C}$ Thermal Resistance Junction-to-Air	285 140	mW $^\circ\text{C}/\text{W}$
$P_{Dt}$ $R_{\theta JA t}$	TSSOP-24 Package: Power Dissipation @ $T_A = 85^\circ\text{C}$ Thermal Resistance Junction-to-Air	220 180	mW $^\circ\text{C}/\text{W}$
$T_A$	Operating Ambient Temperature Range	$-40$ to $+85$	$^\circ\text{C}$
$T_J$	Operating Junction Temperature Range	$-40$ to $+125$	$^\circ\text{C}$
$T_{Jmax}$	Maximum Junction Temperature (Note 3)	150	$^\circ\text{C}$
$T_{stg}$	Storage Temperature Range	$-65$ to $+150$	$^\circ\text{C}$

Maximum ratings are those values beyond which device damage can occur. Maximum ratings applied to the device are individual stress limit values (not normal operating conditions) and are not valid simultaneously. If these limits are exceeded, device functional operation is not implied, damage may occur and reliability may be affected.

1. Maximum electrical ratings are those values beyond which damage to the device may occur.  $T_A = 25^\circ\text{C}$ .
2. Human body model,  $R = 1500 \Omega$ ,  $C = 100 \text{ pF}$ .
3. Maximum thermal rating beyond which damage to the device may occur.

# MC33560

**ELECTRICAL CHARACTERISTICS** These specifications are written in the same style as common for standard integrated circuits. The convention considers current flowing into the pin (sink current) as positive and current flowing out of the pin (source current) as negative. (Conditions:  $V_{BAT} = 4.0\text{ V}$ ,  $V_{CC} = 5.0\text{ V nom}$ ,  $PWRON = V_{BAT}$ , Operating Mode,  $-I_{CC} = 10\text{ mA}$ ,  $-25^{\circ}\text{C} \leq T_A \leq 85^{\circ}\text{C}$ ,  $L_1 = 47\text{ }\mu\text{H}$ ,  $R_{LIM} = 0\text{ }\Omega$ ,  $CRDV_{CC}$  capacitor =  $10\text{ }\mu\text{F}$ , unless otherwise noted.)

Characteristic	Test Conditions	Symbol	Min	Typ	Max	Unit
----------------	-----------------	--------	-----	-----	-----	------

## BATTERY POWER SUPPLY SECTION

Supply Voltage Range Normal operating range extended operating range (Note 4)		$V_{BAT}$	2.2 1.8	– –	6.0 6.6	V
MC33560 Standby Quiescent Current $PWRON = GND$ , $CRDCON = GND$ , $ASYCLKIN = GND$ , $V_{BAT} = 6.0\text{ V}$ , All Other Logic Inputs and Outputs Open		$I_{oBAT}$	–	–	30	$\mu\text{A}$
DC Operating Current $-I_{CC} = 10\text{ mA}$ ; $V_{CC} = 5.0\text{ V}$ , $V_{BAT} = 6.0\text{ V}$		$I_{BATop}$	–	–	12.5	mA
$V_{BAT}$ Undervoltage Detection: Upper Threshold Lower Threshold Hysteresis		–	– – –	1.6 1.4 0.2	– – –	V

## $V_{CC} = 5.0\text{ V}$ NOMINAL POWER SUPPLY SECTION

Output Voltage	$2.2\text{ V} \leq V_{BAT} \leq 6.0\text{ V}$ $1.0\text{ mA} \leq -I_{CC} \leq 25\text{ mA}$ $3.0\text{ V} \leq V_{BAT} \leq 6.0\text{ V}$ $1.0\text{ mA} \leq -I_{CC} \leq 60\text{ mA}$	$V_{CC}$	4.75 4.60	5.0 5.0	5.25 5.40	V
Card $V_{CC}$ Undervoltage Detection: Upper Threshold Lower Threshold Switching Hysteresis	(RDYMOD Output) (See Table 4)	$V_{T5H}$ $V_{T5L}$ $V_{HYS5}$	4.2 120	4.5 180	$V_{CC} - 0.14$	V mV
Peak Output Current	$V_{CC} = 4.0\text{ V}$ , Internally Limited (RDYMOD = L)	$-I_{CClim}$	80	–	–	mA
Current limit time-out	$V_{CC} = 4.0\text{ V}$	$t_d$	–	160	–	ms
Startup Current	$V_{CC} = 2.0\text{ V}$ ; $0^{\circ}\text{C}$ to $+85^{\circ}\text{C}$ $-40^{\circ}\text{C}$ to $0^{\circ}\text{C}$	$-I_{CCst}$	80 50	– –	– –	mA
Low Side Switch Saturation Voltage	$I_L = 50\text{ mA}$ , Pin 22	$V_{sat22}$	–	100	160	mV
Rectifier on Saturation Voltage	$I_L = 50\text{ mA}$ , Pin 22 to Pin 13	$V_{Fsat22}$	–	400	520	mV
Converter Switching Frequency	$T_A = 25^{\circ}\text{C}$	$f_{sw}$	–	120	–	kHz
Shutdown Current (Card access deactivated)	$PWRON = GND$ , $V_{CC} = 2.0\text{ V}$	$I_{SD}$	80	–	–	mA

## $V_{CC} = 3.0\text{ V}$ NOMINAL POWER SUPPLY SECTION ( $V_{BAT} = 2.5\text{ V}$ , $-I_{CC} = 5.0\text{ mA}$ )

Output Voltage	$2.2\text{ V} \leq V_{BAT} \leq 6.0\text{ V}$ $1.0\text{ mA} \leq -I_{CC} \leq 10\text{ mA}$ $2.5\text{ V} \leq V_{BAT} \leq 6.0\text{ V}$ $1.0\text{ mA} \leq -I_{CC} \leq 50\text{ mA}$	$V_{CC}$	2.75 2.60	3.0 3.0	3.25 3.40	V
Card $V_{CC}$ Undervoltage Detection: Upper Threshold Lower Threshold Switching Hysteresis	(RDYMOD Output) (See Table 4)	$V_{T3H}$ $V_{T3L}$ $V_{HYS3}$	2.4 80	2.7 110	$V_{CC} - 0.1$	V mV
Startup Current Shutdown Current (Card access deactivated)	$V_{CC} = 2.0\text{ V}$ $PWRON = GND$ , $V_{CC} = 2.0\text{ V}$	$-I_{CCst}$ $I_{SD}$	50 50	– –	– –	mA

- See Figures 2 and 3.
- The transistors T1 on lines IO, C4 and C8 (see Figure 24) have a max  $R_{dson}$  of  $250\text{ }\Omega$ .
- Pin loading =  $30\text{ pF}$ , except INVOUT =  $15\text{ pF}$ .
- As the clock buffer is optimized for low power consumption and hence not symmetrical, clock signal duty cycle is guaranteed for divide by 2 and divide by 4 ratio.
- In either direction.

# MC33560

**ELECTRICAL CHARACTERISTICS (continued)** These specifications are written in the same style as common for standard integrated circuits. The convention considers current flowing into the pin (sink current) as positive and current flowing out of the pin (source current) as negative. (Conditions:  $V_{BAT} = 4.0\text{ V}$ ,  $V_{CC} = 5.0\text{ V}$  nom,  $PWRON = V_{BAT}$ , Operating Mode,  $-I_{CC} = 10\text{ mA}$ ,  $-25^{\circ}\text{C} \leq T_A \leq 85^{\circ}\text{C}$ ,  $L_1 = 47\text{ }\mu\text{H}$ ,  $R_{LIM} = 0\text{ }\Omega$ ,  $CRDV_{CC}$  capacitor =  $10\text{ }\mu\text{F}$ , unless otherwise noted.)

Characteristic	Test Conditions	Symbol	Min	Typ	Max	Unit
<b>APPLICATION INTERFACE DC SECTION (<math>V_{BAT} = 5.0\text{ V}</math>)</b>						
Input High Threshold Voltage (increasing)	Pins 2, 4, 5, 6, 10, 17	$V_{IH}$	$0.55 \cdot V_{BAT}$	–	$0.65 \cdot V_{BAT}$	V
Input Low Threshold Voltage (decreasing)	Pins 2, 5, 6, 10 Pin 17 Pin 4	$V_{IL}$	$0.3 \cdot V_{BAT}$ $0.2 \cdot V_{BAT}$ $0.3 \cdot V_{BAT}$	– – –	$0.45 \cdot V_{BAT}$ $0.40 \cdot V_{BAT}$ $0.5 \cdot V_{BAT}$	V
Switching Hysteresis	Pins 2, 4, 5, 6, 10, 17	$V_{HYST}$	$0.06 \cdot V_{BAT}$	–	$0.3 \cdot V_{BAT}$	V
Threshold Voltage	Pin 9 Pin 18	$V_{TH}$	$0.5 \cdot V_{BAT}$ $0.4 \cdot V_{BAT}$	– –	$0.6 \cdot V_{BAT}$ $0.6 \cdot V_{BAT}$	V
Pulldown resistance	$V_{IN} = V_{BAT} - 1.0\text{ V}$ , Pins 2, 6, 7, 10	$R_{down}$	120	240	500	k $\Omega$
Pullup resistance	$V_{IN} = 0.5\text{ V}$ , Pin 3, 4, 5	$R_{up}$	120	240	500	k $\Omega$
Output High Voltage	$I_{OH} = -2.5\text{ }\mu\text{A}$ , Pin 3, Pin 4 for $\overline{CS} = H$ $I_{OH} = -50\text{ }\mu\text{A}$ , pins 7, 20, 21 $I_{OH} = -0.2\text{ mA}$ , Pin 8 Pin 4 ( in Output Mode)	$V_{OH}$	$V_{BAT} - 1$	–	–	V
Output Low Voltage	$I_{OL} = 1.0\text{ mA}$ , Pins 7, 20, 21 $I_{OL} = 0.2\text{ mA}$ , Pins 3, 4, 8	$V_{OL}$	–	–	0.4	V
Input Leakage Current	$V_{IN} = 2.5\text{ V}$ , $\overline{CS} = H$ , Pins 9, 17, 18, 20, 21	$\pm I_{leak}$	–	–	2.0	$\mu\text{A}$

## CARD INTERFACE DC SECTION ( $V_{BAT} = 5.0\text{ V}$ )

Output High Voltage	$I_{OH} = -20\text{ }\mu\text{A}$ , Pins 11, 16, 19 $I_{OL} = 0.2\text{ mA}$ , Pins 14, 15	$V_{OH}$	$V_{CC} - 0.9$	–	–	V
Output Low Voltage	$I_{OL} = 1.0\text{ mA}$ , Pins 11, 16, 19 $I_{OL} = 0.2\text{ mA}$ , Pins 14, 15	$V_{OL}$	–	–	0.4	V
I/O Pullup Resistance, Operating Mode, $\overline{CS} = L$ , $PWRON = H$	$V_{OL} = 0.5\text{ V}$ , Pins 11, 16, 19	–	–	18	–	k $\Omega$
Card pins security voltage (Card access deactivated)	$PWRON = GND$ , $I_{in} = 10\text{ mA}$ , Pins 11, 14, 15, 16, 19	$V_{security}$	–	–	2.0	V

## DIGITAL DYNAMIC SECTION ( $V_{BAT} = 5.0\text{ V}$ , Normal Operating Mode) (Note 6)

Input Clock Frequency	Pin 9, Duty Cycle = 50%	$f_{asyck}$	–	–	20	MHz
Card Clock Frequency	Pin 15	$f_{crdclk}$	–	–	20	MHz
Card Clock Duty Cycle (Note 7)	Pin 15, 50% to 50% $V_{CC}$ , $f_{io} = 16\text{ MHz}$	$r_{clk}$	45	–	55	%
Card Clock Rise and Fall Time	Pin 15, 10% $\leftrightarrow$ 90% $V_{CC}$	$t_{rclk}$ , $t_{fclk}$	–	–	10	ns
I/O Data Transfer Frequency	Pin [7, 11], [21, 16], [20, 19] (Note 8)	$f_{io}$	–	1.0	–	MHz
I/O Duty Cycle	Pin [7, 11], [21, 16], [20, 19] (Note 8) 50% to 50% $V_{CC}$	$r_{io}$	45	–	55	%
I/O Rise and Fall Time	Pin [7, 11], [21, 16], [20, 19] (Note 8) 10% $\leftrightarrow$ 90% $V_{CC}$	$t_{rio}$ , $t_{fio}$	–	–	150	ns
I/O Transfer Time	Pin [7, 11], [21, 16], [20, 19] (Note 8) 50% to 50% $V_{CC}$ , $L \rightarrow H$ , $H \rightarrow L$	$t_{tr}$	–	–	100	ns
Card Signal Sequence Interval	Pins 11, 14, 15, 16, 19 $V_{CC}$ Powerup / Powerdown	$t_{dseq}$	–	0.2	1.0	$\mu\text{s}$

4. See Figures 2 and 3.

5. The transistors T1 on lines IO, C4 and C8 (see Figure 24) have a max  $R_{dson}$  of 250  $\Omega$ .

6. Pin loading = 30 pF, except INVOUT = 15 pF.

7. As the clock buffer is optimized for low power consumption and hence not symmetrical, clock signal duty cycle is guaranteed for divide by 2 and divide by 4 ratio.

8. In either direction.

# MC33560

**ELECTRICAL CHARACTERISTICS (continued)** These specifications are written in the same style as common for standard integrated circuits. The convention considers current flowing into the pin (sink current) as positive and current flowing out of the pin (source current) as negative. (Conditions:  $V_{BAT} = 4.0\text{ V}$ ,  $V_{CC} = 5.0\text{ V nom}$ ,  $PWRON = V_{BAT}$ , Operating Mode,  $-I_{CC} = 10\text{ mA}$ ,  $-25^{\circ}\text{C} \leq T_A \leq 85^{\circ}\text{C}$ ,  $L_1 = 47\text{ }\mu\text{H}$ ,  $R_{LIM} = 0\text{ }\Omega$ ,  $CRDV_{CC}$  capacitor =  $10\text{ }\mu\text{F}$ , unless otherwise noted.)

Characteristic	Test Conditions	Symbol	Min	Typ	Max	Unit
----------------	-----------------	--------	-----	-----	-----	------

**DIGITAL DYNAMIC SECTION** ( $V_{BAT} = 5.0\text{ V}$ , Normal Operating Mode) (Note 6)

Card Detection Filter Time: Card Insertion Card Extraction		$t_{f\text{itin}}$ $t_{f\text{itout}}$	50 50	– –	150 150	$\mu\text{s}$ $\mu\text{s}$
Internal Reset Delay	RES, $V_{CC}$ Powerup / Powerdown	$t_{\text{dres}}$	–	20	–	$\mu\text{s}$
Ready Delay Time	Pin 4	$t_{\text{drdy}}$	–	–	2.0	$\mu\text{s}$
PWRON low Pulse Width	$\overline{\text{CS}} = \text{L}$ , Pin 2	$t_{\text{won}}$	2.0	–	–	$\mu\text{s}$

**DIGITAL DYNAMIC SECTION** ( $V_{BAT} = 5.0\text{ V}$ , programming mode) (Note 6)

Data Setup Time RDYMOD, PWRON, RESET, IO	Pins 2, 4, 6, 7	$t_{\text{smod}}$	1.0	–	–	$\mu\text{s}$
Data Hold Time RDYMOD, PWRON, RESET, IO	Pins 2, 4, 6, 7	$t_{\text{hmod}}$	1.0	–	–	$\mu\text{s}$
$\overline{\text{CS}}$ low Pulse Width	Pin 5	$t_{\text{wcs}}$	2.0	–	–	$\mu\text{s}$

4. See Figures 2 and 3.
5. The transistors T1 on lines IO, C4 and C8 (see Figure 24) have a max  $R_{\text{dson}}$  of  $250\text{ }\Omega$ .
6. Pin loading =  $30\text{ pF}$ , except INVOUT =  $15\text{ pF}$ .
7. As the clock buffer is optimized for low power consumption and hence not symmetrical, clock signal duty cycle is guaranteed for divide by 2 and divide by 4 ratio.
8. In either direction.

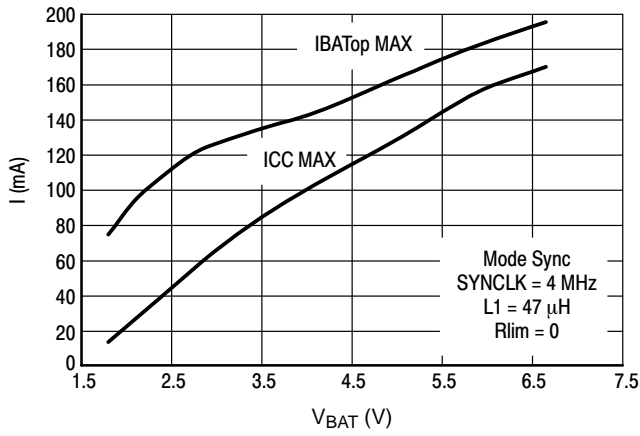

Figure 2. Maximum Battery and Card Supply Current vs.  $V_{BAT}$  ( $V_{CC} = 5.0 V$ )

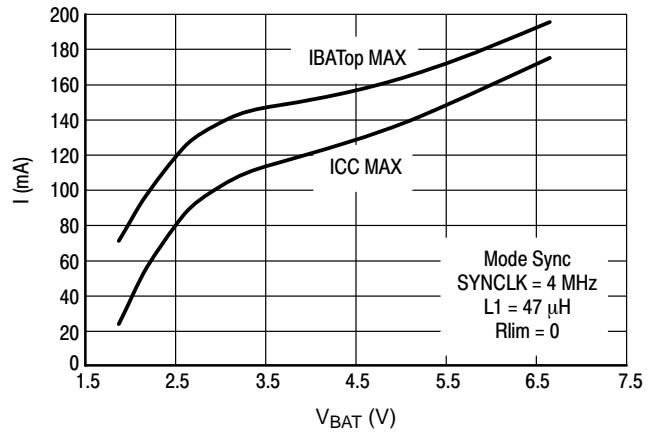

Figure 3. Maximum Battery and Card Supply Current vs.  $V_{BAT}$  ( $V_{CC} = 3.0 V$ )

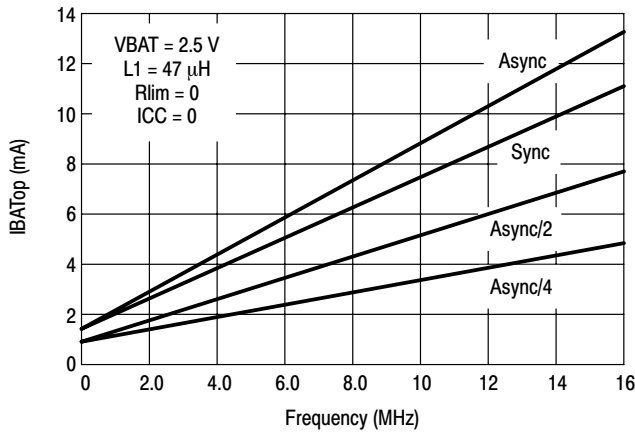

Figure 4. Battery Current vs. Input Clock Frequency ( $I_{CC} = 0$ ,  $V_{BAT} = 4.0 V$ )

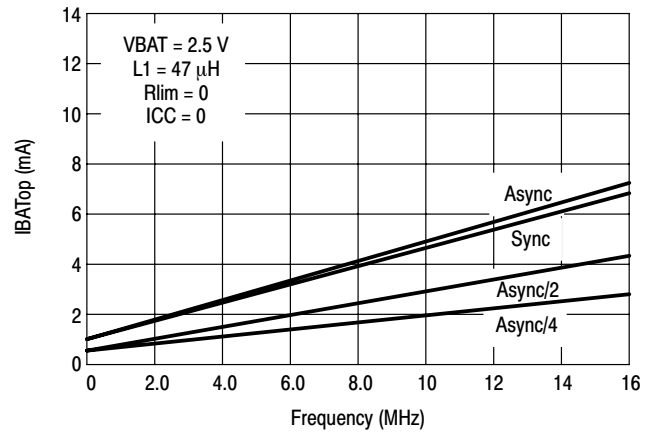

Figure 5. Battery Current vs. Input Clock Frequency ( $I_{CC} = 0$ ,  $V_{BAT} = 2.5 V$ )

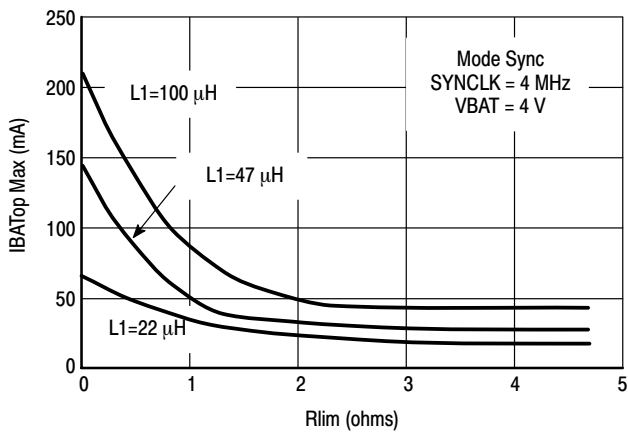

Figure 6. Maximum Battery Current vs.  $R_{LIM}$  ( $V_{CC} = 5.0 V$ ,  $V_{BAT} = 4.0 V$ )

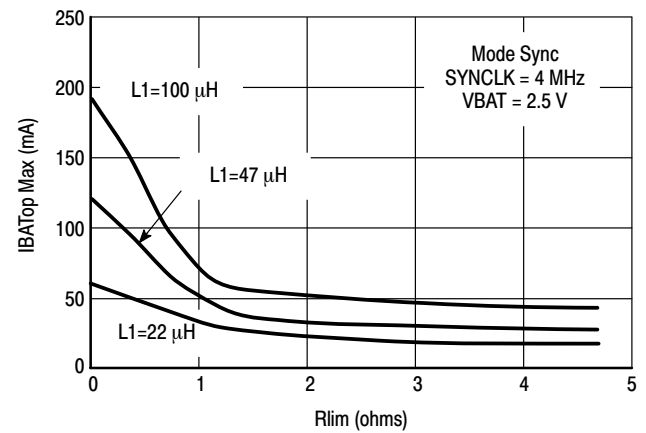

Figure 7. Maximum Battery Current vs.  $R_{LIM}$  ( $V_{CC} = 3.0 V$ ,  $V_{BAT} = 2.5 V$ )

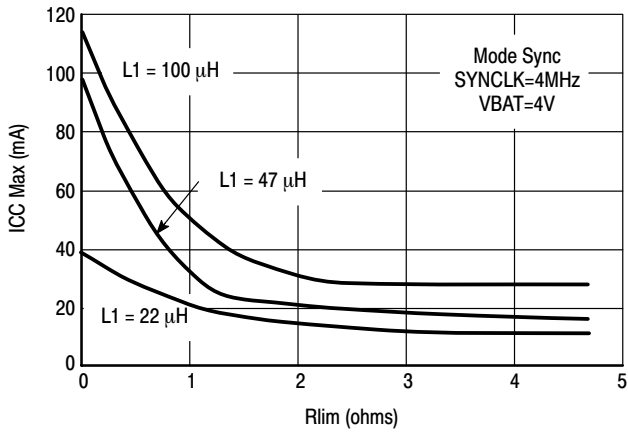

Figure 8. Maximum Card Supply Current vs.  $R_{LIM}$  ( $V_{CC} = 5.0$  V,  $V_{BAT} = 4.0$  V)

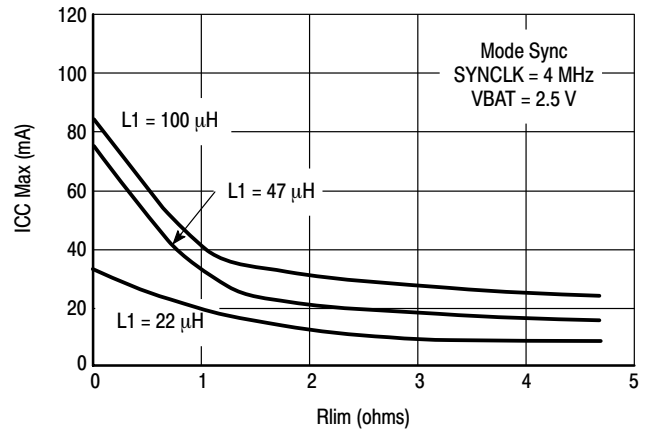

Figure 9. Maximum Card Supply Current vs.  $R_{LIM}$  ( $V_{CC} = 3.0$  V,  $V_{BAT} = 2.5$  V)

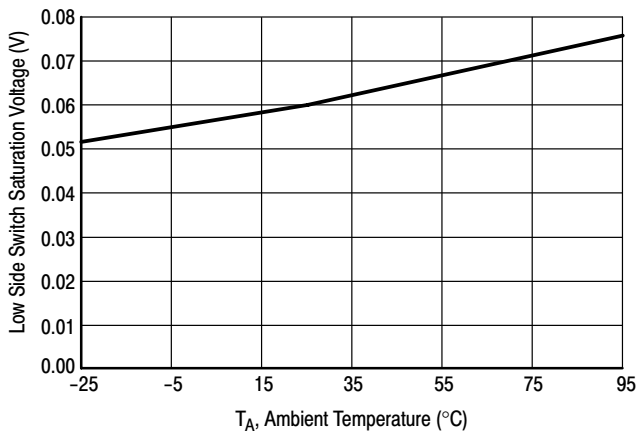

Figure 10. Low Side Switch Saturation Voltage ( $I_L = 50$  mA) vs. Temperature

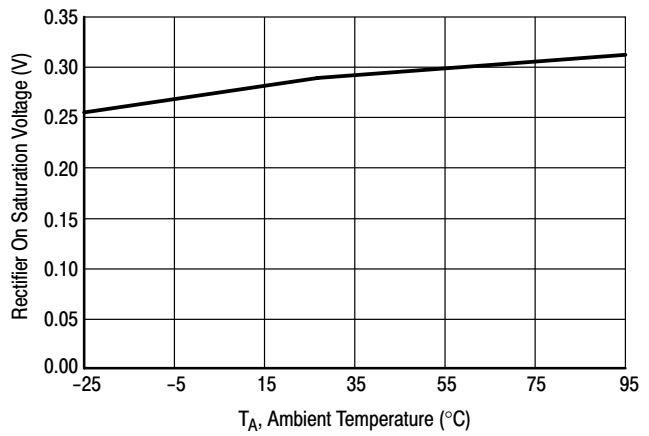

Figure 11. Rectifier On Saturation Voltage ( $I_L = 50$  mA) vs. Temperature

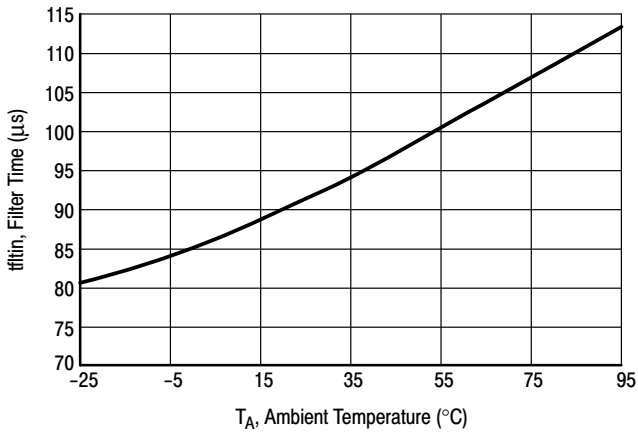

Figure 12. Card Detection (Insertion) Filter Time vs. Temperature

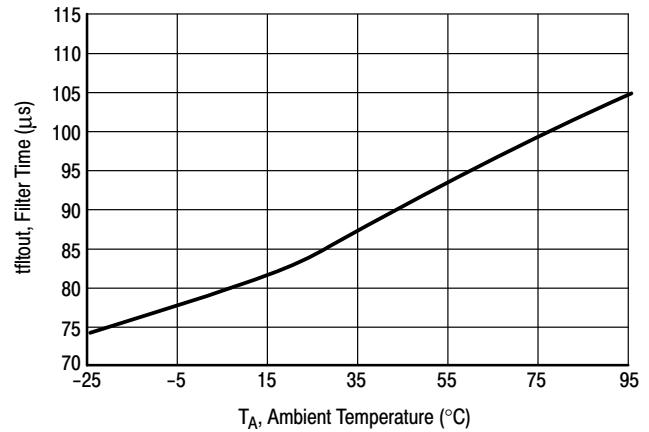

Figure 13. Card Detection (Extraction) Filter Time vs. Temperature

# MC33560

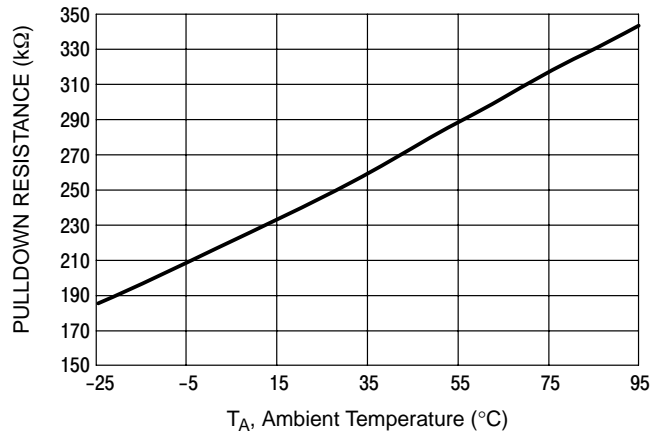

Figure 14. Pulldown Resistance vs. Temperature

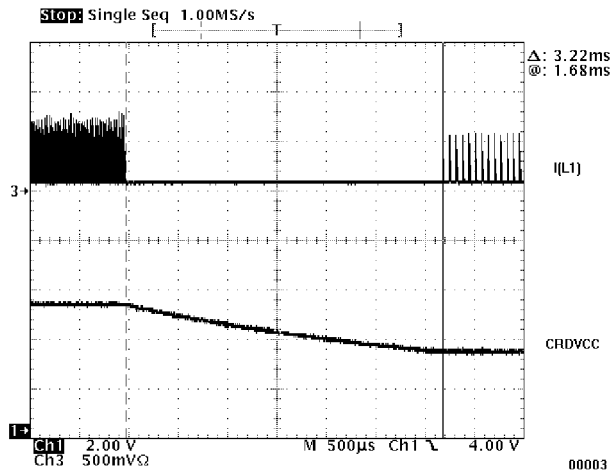

Figure 15. Transition from 5.0 V to 3.0 V Card Supply

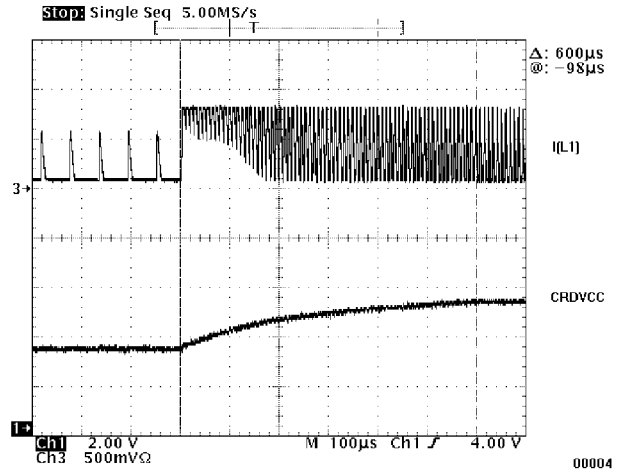

Figure 16. Transition from 3.0 V to 5.0 V Card Supply

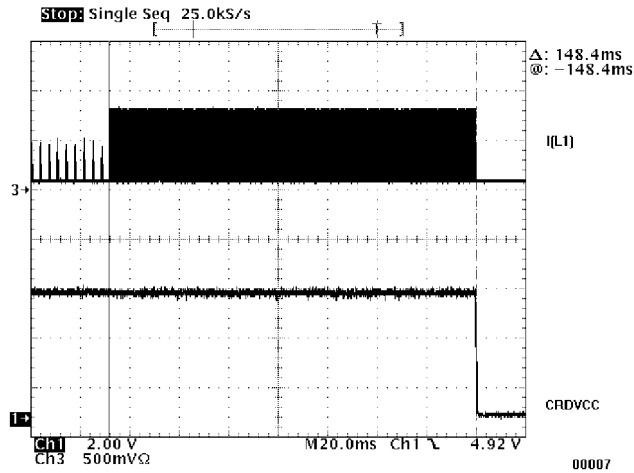

Figure 17. Overcurrent Shutoff ( $t_d = 160$  ms)

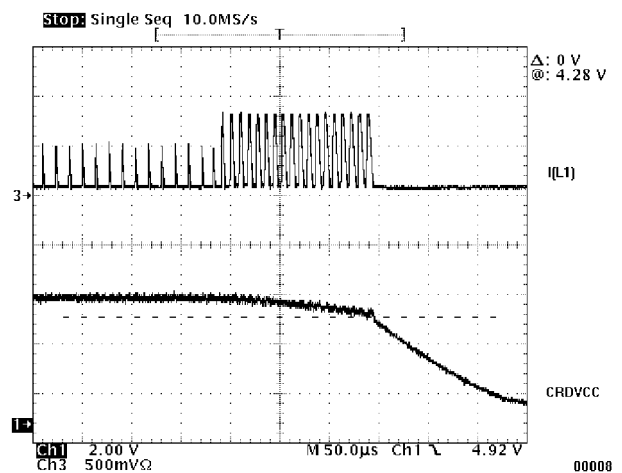

Figure 18. Undervoltage Shutoff ( $V_{T5L} = 4.6$  V)



# MC33560

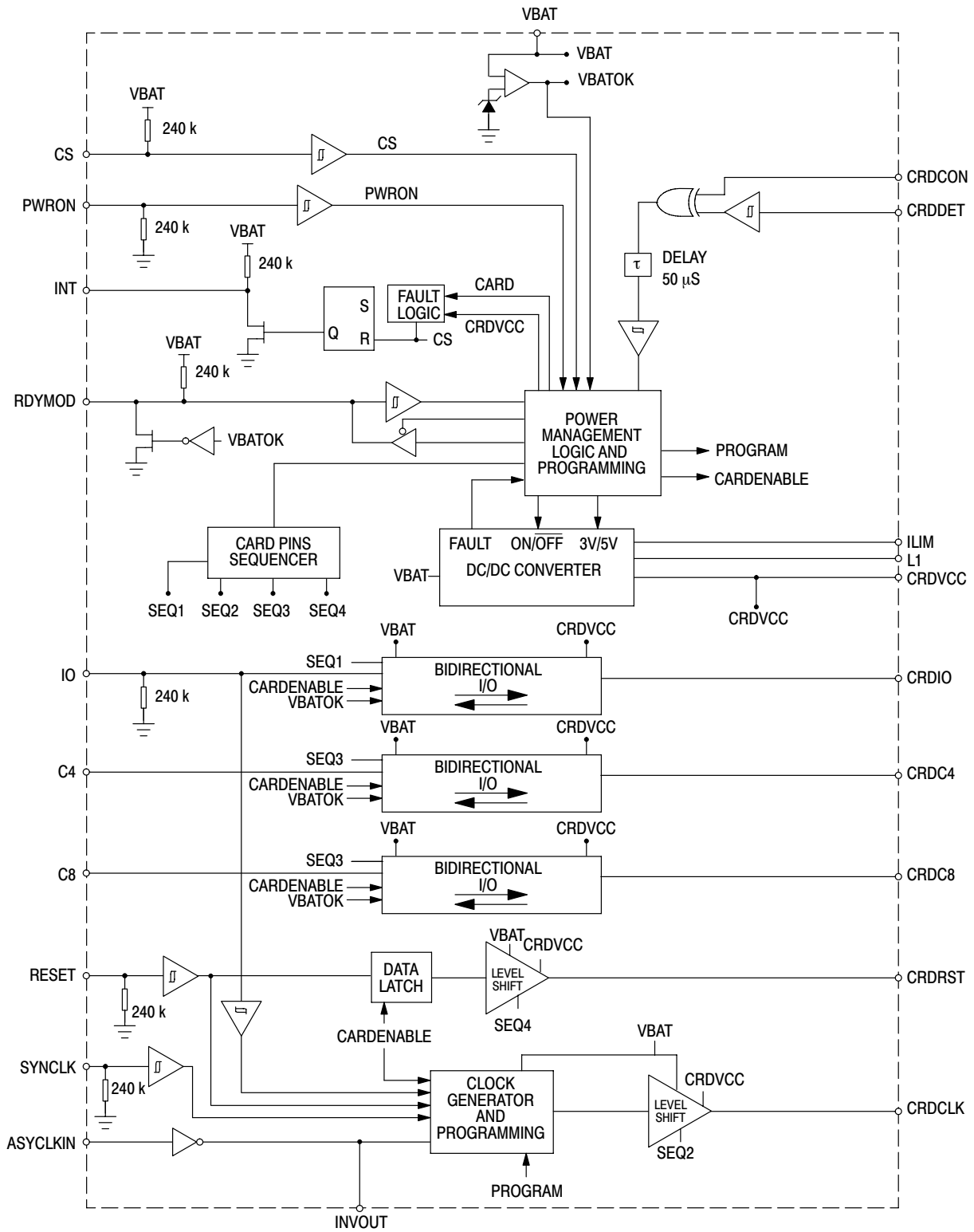

Figure 19. Functional Block Diagram

Table 1. PIN FUNCTION DESCRIPTION

Pin	Symbol	Type	Name/Function
<b>CONTROLLER INTERFACE</b>			
2	PWRON	INPUT Pulldown	This pin is used to start operation of the internal DC–DC converter. In programming mode, this pin is used to set the “Output Voltage” switch. (See Table 2).
3	INT	OUTPUT Pullup	This open collector pin indicates a change in the card presence circuit status. When a card is inserted or extracted, the pin goes to logic level “0”. The signal is reset to logic level “1” upon the rising edge of $\overline{CS}$ or upon the rising edge of PWRON. In the case of a multislot application, two or more INT outputs are connected together and the microcontroller has to poll all the MC33560s to identify which slot was detected.
4	RDYMOD	I/O and Pullup	This bidirectional pin has tri–state output and Schmitt trigger input. * When RDYMOD is forced to 0, the MC33560 can be set to programming mode by a negative transition on $\overline{CS}$ . * When RDYMOD is connected to a high impedance, the MC33560 is in normal operating mode, and RDYMOD is in output mode (See Tables 2 and 4): – With $\overline{CS} = L$ and PWRON=H, RDYMOD indicates the status of the DC–DC converter. – With $\overline{CS} = L$ and PWRON=L, RDYMOD indicates the status of the card detector.
5	CS	INPUT Pullup	This is the MC33560 chip select signal. Pins 2, 6, 7, 10, 20, 21 are disabled when $\overline{CS} = H$ . When RDYMOD = L, the MC33560 enters programming mode upon the falling edge of $\overline{CS}$ . (Figure 20)
6	RESET	INPUT Pulldown	The signal present at this input pin is translated to Pin 14 (the card reset signal) when $\overline{CS} = L$ . The signal on this pin is latched when $\overline{CS} = H$ . This pin is also used in programming mode. (See Table 2)
7	I/O	I/O	This pin connects to the Serial I/O port of a microcontroller. A bi–directional level translator adapts the serial I/O signal between the smartcard and the microcontroller. The level translator is enabled when $\overline{CS} = L$ . The signal on this pin is latched when $\overline{CS}=H$ . This pin is also used in programming mode. (See Table 2)
8	INVOUT	CLK OUTPUT	The ASYCLKIN (Pin 9) signal is buffered and inverted to generate the output signal INVOUT. This output is used for multislot applications, where the ASYCLKIN inputs and INVOUT outputs are daisy–chained. (See the multislot application example in Figure 31)
9	ASYCLKIN	CLK INPUT high impedance	This pin can be connected to the microcontroller master clock or any clock signal for asynchronous cards. The signal is fed to the internal clock selector circuit, and is translated to CRDCLK at the same frequency, or divided by 2 or 4, depending on programming. (See Table 3)
10	SYNCLK	CLK INPUT Pulldown	This function is used for communication with synchronous cards, and the pin is generally connected to the controller serial interface clock signal. The signal is fed to the internal clock selector circuit, and is translated to CRDCLK upon appropriate programming of the MC33560 (See Table 3). When selected at programming, the signal on this pin is latched when $\overline{CS} = H$ .
20	C8	I/O	General purpose input/output. It has the same behavior as I/O, except for programming. It can be connected to a bidirectional port of the microcontroller. The level translator is enabled when $\overline{CS} = L$ , and the signal is latched when $\overline{CS} = H$ . (Compare with Pin 19)
21	C4	I/O	General purpose input/output. It has the same behavior as I/O, except for programming. It can be connected to a bidirectional port of the microcontroller. The level translator is enabled when $\overline{CS} = L$ , and the signal is latched when $\overline{CS} = H$ . (Compare with Pin 16)
<b>CARD INTERFACE</b>			
11	CRDIO	I/O	This pin connects to the serial I/O pin of the card connector. A bidirectional level translator adapts the serial I/O signal between the card and the microcontroller. (Compare with Pin 7)
14	CRDRST	OUTPUT	This pin connects to the RESET pin of the card connector. A level translator adapts the RESET signal driven by the microcontroller. (Compare with Pin 6)
15	CRDCLK	OUTPUT	This pin connects to the CLK pin of the card connector. The CRDCLK signal is the output of the clock selector circuit. The clock selection is programmed using Pins 2, 6 and 7 with RDYMOD forced to “0”.
16	CRDC4	I/O	General purpose input/output. It has the same behavior as CRDIO. It can be connected to the C4 pin of the card connector.
17	CRDDET	INPUT high impedance	This pin connects to the card detection switch of the card connector. Card detection phase is determined with Pin 18. This pin needs an external pullup or pulldown resistor to operate properly.
18	CRDCON	INPUT high impedance	This pin connects to PGND or $V_{BAT}$ , or possibly to an output port of the microcontroller. With this pin set to a logic “0”, the presence of a card is signalled with a logic “1” on Pin 17. With this pin set to a logic “1”, the presence of a card is signalled with a logic “0” on Pin 17.

# MC33560

**Table 1. PIN FUNCTION DESCRIPTION**

Pin	Symbol	Type	Name/Function
<b>CARD INTERFACE</b>			
19	CRDC8	I/O	General purpose input/output. It has the same behavior as CRDIO. It can be connected to the C8 pin of the card connector.
<b>CURRENT LIMIT AND THERMAL PROTECTION</b>			
1	PGND	POWER	This pin is the return path for the current flowing into Pin 22 (L1). It must be connected to CRDGND using appropriate grounding techniques.
12	CRDGND	POWER	This pin is the signal ground. It must be connected to the ground pin of the card connector. It is the reference level for all analog and digital signals.
13	CRDV <sub>CC</sub>	POWER	This pin connects to the V <sub>CC</sub> pin of the card connector. It is the reference level for a logic "1" of Pins 11, 14, 15, 16 and 19.
22	L1	POWER	This pin connects to an external inductance for the DC–DC converter. Please refer to the description of the DC–DC converter functional block.
23	V <sub>BAT</sub>	POWER	This pin is connected to the supply voltage. Logic level "1" of Pins 2 to 10, 17, 18, 20 and 21 is referenced to V <sub>BAT</sub> . Operation of the MC33560 is inhibited when V <sub>BAT</sub> is lower than the minimum value.
24	ILIM	POWER	This pin can be connected to the PGND pin, or to a resistor connected to PGND, or left open, depending on the peak coil current needed to supply the card.

## PROGRAMMING AND STATUS FUNCTIONS

The MC33560 features a programming interface and a status interface. Figure 20 shows how to enter and exit programming mode; Table 2 shows which pins are used to access the various functions.

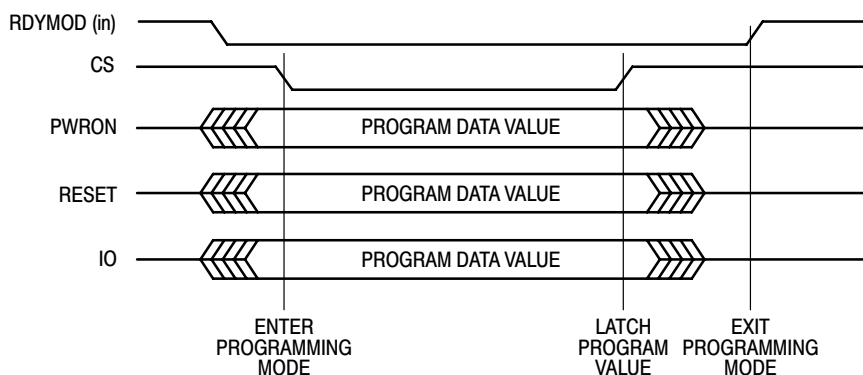

**Figure 20. MC33560 Programming Sequence**

**Table 2. PIN USE FOR PROGRAMMING AND STATUS FUNCTIONS**

	Programs CRDV <sub>CC</sub> TO 3 V/5 V	Select V <sub>CC</sub> ON/OFF	Select Clock Input	Program ASYCLKIN Divide Ratio	Poll Card Status	Poll CRDV <sub>CC</sub> Status
<b>RDYMOD (In/Out)</b>	Force to 0	READ	Force to 0	Force to 0	READ	READ
<b>CS (In)</b>	rising edge	0	rising edge	rising edge	0	0
<b>PWRON</b>	0/1	0/1	Programs CRDV <sub>CC</sub>	Programs CRDV <sub>CC</sub>	0 or Hi-z	1
<b>RESET(In)</b>	Programs CLK Input/Divide Ratio	NOT USED	0/1	0/1	NOT USED	NOT USED
<b>I/O(In)</b>	Programs CLK Input/Divide Ratio	NOT USED	0/1	0/1	NOT USED	NOT USED

### CARD V<sub>CC</sub> AND CARD CLOCK PROGRAMMING

The CRDV<sub>CC</sub> and ASYCLK programming options allow the system clock frequency to be matched to the card clock frequency and to select 3.0 V or 5.0 V CRDV<sub>CC</sub> supply. Table 3 shows the values of **PWRON**, **RESET** and **I/O** for the possible options. The default power reset condition is state 4 (synchronous clock and CRDV<sub>CC</sub> = 5.0 V). All states are latched for each output variable in programming mode at the positive transition of  $\overline{CS}$  (Figure 20).

**Table 3. CARD V<sub>CC</sub> AND CARD CLOCK TRUTH TABLE**

STATE#	PWRON	RESET	I/O	CRDV <sub>CC</sub>	CRDCLK
0	L	L	L	3 V	SYNCLK
1	L	L	H	3 V	ASYCLKIN/4
2	L	H	H	3 V	ASYCLKIN/2
3	L	H	L	3 V	ASYCLKIN
4	H	L	L	5 V	SYNCLK
5	H	L	H	5 V	ASYCLKIN/4
6	H	H	H	5 V	ASYCLKIN/2
7	H	H	L	5V	ASYCLKIN

NOTE: Card clock integrity is maintained during all frequency commutations (no spikes).  
State 4 is the default state at power on.

### DC-DC CONVERTER AND CARD DETECTOR STATUS

The MC33560 status can be polled when  $\overline{CS} = L$ . Please consult Table 2 for a description of input and output signals. The significance of the status message is described in Table 4.

**Table 4. RDYMOD STATUS MESSAGES**

PWRON (Input)	RDYMOD (Output)	Message
LOW	LOW	No card
LOW	HIGH	Card present
HIGH	LOW	DC-DC converter overload
HIGH	HIGH	DC-DC converter OK

### DETAILED OPERATING DESCRIPTION

#### INTRODUCTION

The MC33560 Smartcard interface IC has been designed to provide all necessary functions for safe data transfers between a microcontroller and a smartcard or memory card.

A card detector scans for the presence of a card and generates a debounced wake-up signal to the microcontroller.

Communication and control signal levels are translated between the digital interface and the card interface by the voltage level translator, and the card clock is matched to the system clock frequency by the programmable card clock

generator. The power management unit enables the DC-DC converter for card power supply, supervises the powerup/down sequence of the card's I/O and signal lines, and keeps the power consumption very low in standby mode.

All card interface pins have adequate ESD protection, and fault monitoring ( $V_{BATlow}$ ,  $V_{CClow}$ ,  $I_{CClim}$ ) guarantees hazard free card reader operation.

Several MC33560s can be operated in parallel, using the same control and data bus, through the use of the chip select signal CS.

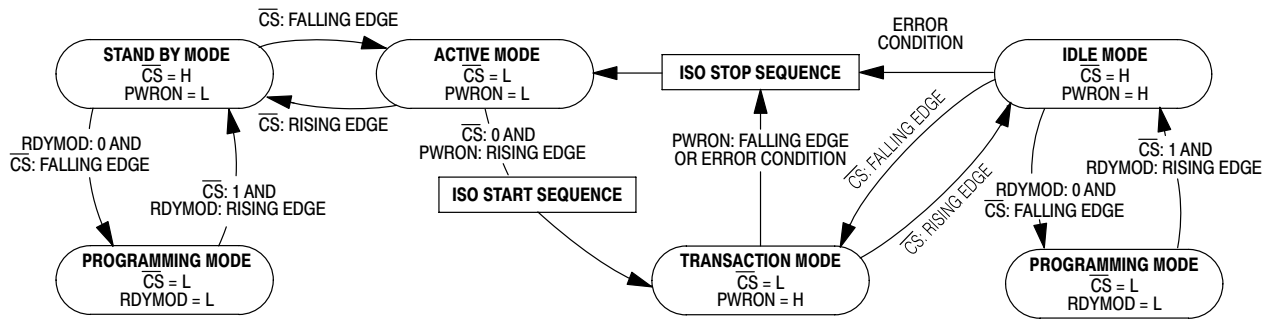

Figure 21. MC33560 Operating Modes

## OPERATING MODES

The MC33560 has five operating modes:

- Standby
- Programming
- Active
- Transaction
- Idle

The transitions between these different states are shown in Figure 21 above.

### STANDBY MODE

Standby mode allows the MC33560 to detect card insertion and monitor the power supply while keeping the power consumption at a minimum. It is obtained with  $\overline{CS} = H$  and  $PWRON = L$ .

When the MC33560 detects a card,  $\overline{INT}$  is asserted low to wake up the Microcontroller.

### PROGRAMMING MODE

The programming mode allows the user to configure the card  $V_{CC}$  and the card clock signal for his specific application. The card supply,  $CRDV_{CC}$ , can be programmed to 3 V or 5 V, and the card clock signal can be defined to be either synchronous, or asynchronous divided by 1, 2 or 4.

Programming mode is obtained with  $RDYMOD = L$  followed by a negative transition on  $\overline{CS}$ . The programming options are shown in Table 3. Programmed values are latched on a positive transition of  $\overline{CS}$  with  $RDYMOD = L$ .

### ACTIVE MODE

In active mode, the MC33560 is selected, the  $RDYMOD$  pin becomes an output, and the MC33560 status can be polled. Power is not applied to the card.

The microcontroller polls the MC33560 by asserting  $\overline{CS} = L$  and reading the  $RDYMOD$  pin.

If a card is present, the microcontroller starts the DC–DC converter by asserting  $PWRON = H$ . This starts the automatic power on sequence: when  $CRDV_{CC}$  reaches the undervoltage level ( $V_{T5H}$  or  $V_{T3H}$ , depending on programming), the card sequencer validates  $CRDIO$ ,  $CRDRST$ ,  $CRDCLK$ ,  $CRDC4$ ,  $CRDC8$  pins according to the ISO7816–3 sequence (Figure 26). The MC33560 is now in transaction mode, and the system is ready for data exchange via the three I/O lines and the  $RESET$  line.

### TRANSACTION MODE

In transaction mode, the MC33560 maintains power and the selected clock signal applied to the card, and the levels of the  $I/O$ ,  $RESET$ ,  $C4$  and  $C8$  signals between the microcontroller and the card are translated depending on the supply voltages  $V_{BAT}$  and  $V_{CC}$ .

The DC–DC converter status can be monitored on the  $RDYMOD$  pin.

### IDLE MODE

Idle mode is used when maintaining a card powered up without communicating with it. When an asynchronous clock is used, the selected clock signal is applied to the card.

### POWERDOWN OPERATION

Powerdown can be initiated by the controlling microprocessor, by stopping the DC–DC converter with  $PWRON = L$  while  $\overline{CS} = L$ , or by the MC33560 itself when an error condition has been detected ( $CRDV_{CC}$  undervoltage, overcurrent longer than 160 ms typ., overtemperature, “hot” card extraction). The communication session is terminated in a given sequence defined in ISO7816–3.

The MC33560 then goes into active mode, in which its status can be polled.

Standby mode is reached by deselecting the MC33560 ( $\overline{CS} = H$ ).

## FUNCTIONAL BLOCKS

### CARD DETECTOR

This block monitors the card contact  $CRDDET$  (during insertion and extraction), filters the incoming waveform and generates an interrupt signal  $\overline{INT}$  after each change. In order to identify which coupler activated the  $\overline{INT}$  line (multicoupler application) the microcontroller scans both circuits via  $\overline{CS}$  and reads the  $RDYMOD$  pin.

The programming input  $CRDCON$  tells the level detector which type of mechanical contact is implemented (normally open or normally closed). Special care is taken to hold the current consumption very low on this part of the circuit which is continuously powered by the  $V_{BAT}$  supply.

The  $CRDDET$  pin has high impedance input, and an external resistor must be connected to pullup or pulldown, depending on  $CRDCON$ . This resistor is chosen according to the maximum leakage current of the card connector and the PCB.

The card detector has an internal 50  $\mu$ s debouncing delay. The micro controller has to insert an additional delay (in the ms range) to allow the card contacts to stabilize in the card connector before setting **PWRON = H**.

When the card detector circuit detects a card extraction, it activates the powerdown sequence and stops the converter, regardless of the **PWRON** signal. The 50  $\mu$ s delay of the debouncer is enough to ensure that all card signals have reached a safe value before communication with the card takes place.

### CARD STATUS

The controlling microprocessor is informed of the MC33560 status by interrupt and by polling. When a card is extracted or inserted, the **INT** line is asserted low. The interrupt is cleared upon the rising edge of **CS** or upon the rising edge of **PWRON** (**INT** line set to high state).

The microprocessor can poll the status at any time by reading the **RDYMOD** pin with proper **PWRON** setting (see Tables 2 and 4).

Since **INT** and **RDYMOD** have a high value pullup resistor (240 k $\Omega$  typical), their rise time can be as long as 10  $\mu$ s if parasitic capacitance is high and no other pullup circuitry is connected.

### POWER MANAGER

The task of the power manager is to activate only those circuit functions which are needed for a determined operating mode in order to minimize power consumption (Figure 19).

In standby mode (**PWRON = L**) the power manager keeps only the “card present” detector alive. All card interface pins are forced to ground potential.

In the event of a powerup request from the microcontroller (**PWRON L to H** transition, **CS = L**) the power manager starts the DC–DC converter. As soon as the **CRDV<sub>CC</sub>** supply reaches the operating voltage range, the circuit activates the card signals in the following sequence:

**CRDV<sub>CC</sub>**, **CRDIO**, **CRDCLK**, **CRDC4/C8**, **CRDRST**

At the end of the transaction (**PWRON** reset to **L**, **CS = L**) or forced card extraction, the **CRDV<sub>CC</sub>** supply powers down and the card signal deactivation sequence takes place:

**CRDRST**, **CRDC4/C8**, **CRDCLK**, **CRDIO**, **CRDV<sub>CC</sub>**

When **CS = L**, the bi-directional signal lines (**I/O**, **C4** and **C8**) are put into high impedance state to avoid signal collision with the microcontroller in transmission mode.

### BATTERY UNDERVOLTAGE DETECTOR

The task of this block is to monitor the supply voltage, and to allow operation of the DC–DC converter only with valid voltage (typically 1.5 V). The comparator has been designed to have stability better than 20 mV in the temperature range.

### DC–DC CONVERTER

Upon request from the power manager, the DC–DC converter generates the **CRDV<sub>CC</sub>** supply for the smartcard.

The output voltage is programmable for 3.0 V or 5.0 V (see Table 3) to guarantee full cross compatibility of the reader for 5.0 V and 3.0 V smartcards. The wide voltage supply range,  $1.8 \text{ V} < V_{\text{BAT}} < 6.6 \text{ V}$ , accommodates a broad range of coupler applications with different battery configurations (single cell or multiple cells, serial or parallel connections).

The **CRDV<sub>CC</sub>** is current-limited and short-circuit-proof. To avoid excessive battery loading during a card short-circuit, a current integration function forces the powerdown sequence (Figure 28). To retry the session, the microprocessor works through the power on sequence as defined in the power manager section.

### DC–DC CONVERTER OPERATING PRINCIPLES

The DC–DC converter architecture used in the MC33560 allows step-up and step-down voltage conversion to be done. The unique regulation architecture permits an automatic transition from step-up to step-down, and from zero to full load, without affecting the output characteristics.

**DC–DC Converter Description:** The converter architecture is very similar to the boost architecture, with an active rectifier in place of the diode. The switching transistor is connected to ground through a resistor network in order to adjust the maximum peak current (Figure 22). A transistor connected to the converter output (**CRDV<sub>CC</sub>**) forces this pin to a low voltage when the converter is not operating. This prevents erratic voltage supply to the smartcard when not in use.

The MC33560 has a built in oscillator; the DC–DC converter requires only one inductor and the output filtering capacitor to operate.

**Stepup Operation:** When the card supply voltage is lower than the battery voltage, the converter operates like a boost converter; the active rectifier behavior is similar to that of a diode.

**Stepdown Operation:** When the card supply voltage is higher than the battery voltage, the rectifier control circuit puts the power rectifying transistor in conduction when the  $L_1$  voltage reaches  $V_{\text{BAT}} + V_{\text{FSAT}2}$ . The voltage across the rectifying transistor is higher than in step-up operation. The efficiency is lower, and similar to a linear regulator.

**Fault Detection:** The DC–DC converter has several features that help to avoid electrical overstress of the MC33560 and of the smartcard, and help to ensure that data transmission with the smartcard occurs only when its supply voltage is within predetermined limits. These functions are:

- Overtemperature Detection,
- Current Limitation, and
- Card Supply Undervoltage Detection.

The level at which current will be limited is defined by the maximum card supply current programmed with the external components  $L_1$  and  $RLIM$ .

The undervoltage detection levels for 3.0 V and 5.0 V card supply are preset internally to the MC33560.

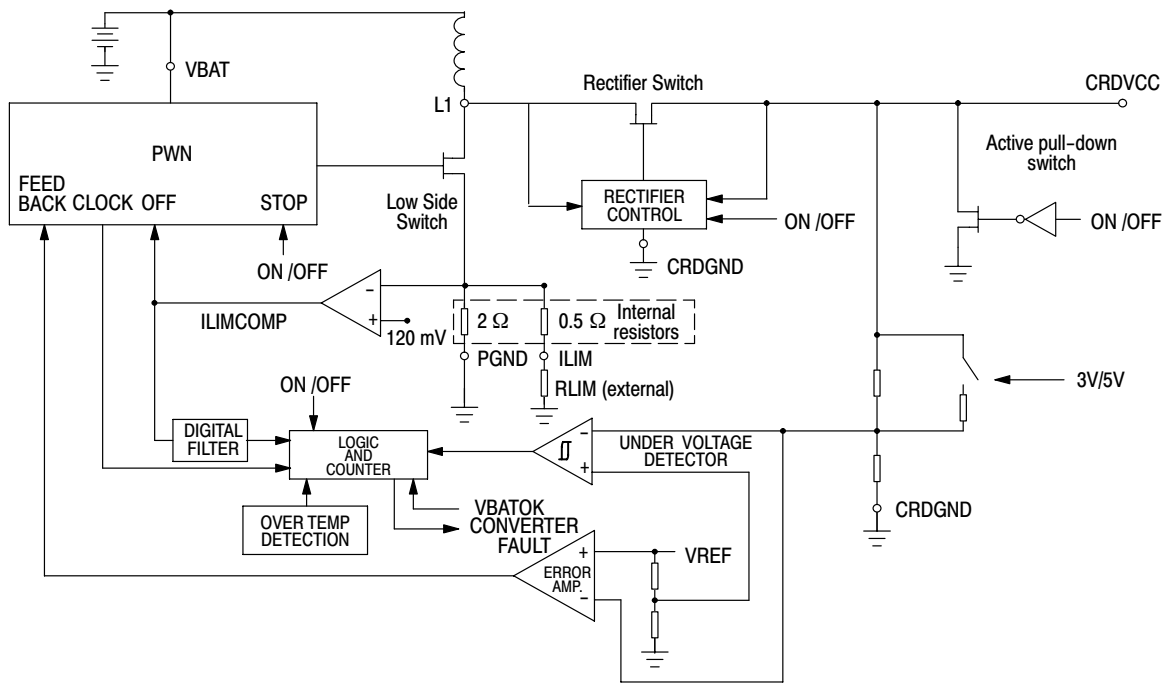

Figure 22. DC-DC Converter Functional Block

The overcurrent and undervoltage protection features are complementary, and will shut the circuit off either if the overcurrent is high enough to bring the  $CRDV_{CC}$  output below the preset threshold, either after 160 ms (typ.)

In addition, the DC-DC converter will be allowed to start only if the battery supply voltage is high enough to allow normal operation (1.8 V).

The undervoltage comparator has a hysteresis and a delay of typically 20 ms to ensure stable operation. The current detector is a comparator associated with two resistors: one  $2.0\ \Omega$  attached to  $PGND$  and usually connected to analog ground, and a  $0.5\ \Omega$  attached to  $ILIM$ , usually connected to ground through an external resistor to adjust the maximum peak current. The voltage developed across this resistor network is then compared to a 120 mV (typical) reference voltage, and the comparator output performs a cycle-by-cycle peak current limitation by switching off the low side transistor when the voltage exceeds 120 mV.

The internal  $ILIMCOMP$  signal is monitored to stop the converter if current limitation is continuously detected during 160 ms (typical). This allows normal operation with high filtering capacitance and low peak current, even at converter startup. As a result, a short circuit to ground on the card connector or a continuous overcurrent is reported by  $RDYMOD$  160 ms (typical) after powerup.

**Unexpected Card Extraction:** The MC33560 detects card extraction and runs a powerdown sequence if card power is still on when extraction occurs. An active pulldown switch clamps  $CRDV_{CC}$  to GND within 150  $\mu s$  (max) after extraction is detected. The external capacitors will then be discharged. With typical capacitor values of 10  $\mu F$  and 47 nF as indicated in the application schematic, the time needed to discharge  $CRDV_{CC}$  to a voltage below 0.4 V can be

estimated to less than 750  $\mu s$ . The total time aftercard extraction detection until  $CRDV_{CC}$  reaches 0.4 V is then estimated to 900  $\mu s$  (maximum). All smartcard connector contacts will be deactivated before  $CRDV_{CC}$  deactivation. This ensures that no electrical damage will be caused to the smartcard under abnormal extraction conditions.

**3.0 V/5.0 V Programming:** It is possible to set the card supply voltage to 3.0 V or 5.0 V at any time, before DC-DC converter start, or during converter operation. When switching from 3.0 V to 5.0 V, a 160 ms (typical) delay blanks the undervoltage fault detection to allow filter capacitor charging.

**PWM:** The free-running integrated oscillator has two working modes:

Variable on-state and fixed frequency (typically 120 KHz) for average to heavy loads.

Variable on-state and variable frequency for light loads.

The frequency can be as low as a few kHz if no load is connected to  $CRDV_{CC}$ .

The charging current of the timing capacitor is related to the  $V_{BAT}$  supply voltage, to allow better line regulation, and to increase stability.

**Filtering Capacitor:** A high value allows efficient filtering of card current spikes. Low values allow low startup charging current. Care must be taken not to combine low capacitor value with high current limiting, as this can generate high ripple. Usual values range from 4.7  $\mu F$  to 47  $\mu F$ , depending on current limiting.

**Selecting the External Components L1 and RLIM:** The choice of inductor L1 and resistor R4 is made by using Figure 8 (5.0 V card) and/or Figure 9 (3.0 V card) on page 8:

First, determine the maximum current that the application requires to supply to the card ( $ICC_{max}$ , on the y-axis)

Then, select one curve that crosses the selected  $ICC_{max}$  level. The curve is associated with an inductance value (22  $\mu$ H, 47  $\mu$ H, or 100  $\mu$ H).

Finally, use the intersection of the curve and the  $ICC_{max}$  level to find the  $R_{lim}$  value on the x-axis.

Good starting values are :  $L1 = 47 \mu\text{H}$ ;  $R_{lim} = 0.5 \Omega$

Note also that, for a high inductance value (100  $\mu$ H), the filtering capacitor is generally charged before inductance current reaches current limitation, while for a low inductance value, the current limitation is activated after a few converter cycles.

**Battery Requirements:** Having determined the  $L1$  and  $R_{lim}$  values, the maximum current drawn from the battery supply is shown by the curves in Figures 6 and 7.

When the application is powered by a single 3.0 V battery, special care has to be taken to extend its lifetime. When lithium batteries approach the end-of-life, their internal resistance increases, while voltage decreases. This phenomenon can prevent the startup of the DC-DC converter if the current limiting is set too high, because of the filtering capacitor charging current.

### CLOCK GENERATOR

The primary purpose of the clock generator module is to match the smartcard operating frequency to the system frequency. The source frequency can be provided to **ASYCLKIN** by the microcontroller itself or from an external oscillator circuit.

In programming mode ( $RDYMOD=L$  and  $\overline{CS}$  asserted low) the three input variables **PWRON**, **I/O** and **RESET** are used to configure the two output variables **CRDVCC** and **CRDCLK** as described in Table 3. This circuit setup is latched during the positive transition of  $\overline{CS}$ .

Furthermore, in asynchronous mode the system clock frequency **ASYCLKIN** can be divided by a factor of 1, 2 or 4. The circuit controls the frequency commutation to guarantee that the card clock signal remains free from spikes and glitches. In addition, this circuit ensures that **CRDCLK** signal pulses will not be shorter than the shortest and/or longer than the longest of the clock signals present before and after programming changes.

The **INVOUT** output is provided to drive other circuits without additional load to the microprocessor quartz oscillator. It can also be used to build a local RC oscillator. This driver has been optimized for low consumption; it has no hysteresis, and input levels are not symmetrical. If the **ASYCLKIN** pin is connected to a sine wave, the duty cycle will not always be 50% at **INVOUT**.

### CLOCK GENERATOR OPERATING PRINCIPLES

**Synchronous Clock:** This clock is used mainly for memory cards. It can also be used for asynchronous (microprocessor) cards, allowing the use of two different clock sources. The status of **SYNCLK** is latched at **CRDCLK** when  $\overline{CS}$  goes high, so that data (the **I/O** pin) and clock are always consistent at the card connector, whatever the  $\overline{CS}$  status is. When using the synchronous clock, the clock output becomes active only when the MC33560 is selected with  $\overline{CS}$ .

**Asynchronous Clock:** This clock is used mainly for microprocessor cards. When applied, the clock output remains active even when the MC33560 is not selected with  $\overline{CS}$ , in order to keep the microprocessor running and avoid an unwanted reset. The **ASYCLKIN** signal is buffered at the **INVOUT** pin, so that several MC33560 systems can use the same clock with one load only.

Depending on programming, the frequency is fed directly, or divided by 2 or by 4 to the **CRDCLK** pin. If the duty cycle of the applied clock signal is not exactly symmetrical, it is recommended that the clock signal be divided by two or four to guarantee 50% duty cycle.

**Clock Signal Synchronization and Consistency** (Figure 29). The clock divider includes synchronization logic that controls the switch from synchronous clock to asynchronous (and vice-versa), from any division ratio to any other ratio, during  $\overline{CS}$  changes and at powerup. The synchronization logic guarantees that each clock cycle on the **CRDCLK** pin is finished before changing clock selection (and has always the adequate duration), regardless of the moment the programming is changed.

At powerup, when **ASYCLKIN** is selected, the clock signal at the **CRDCLK** pin has an entire length, according to the selected divide ratio, whatever the **ASYCLKIN** signal is versus the internal sequencer timing.

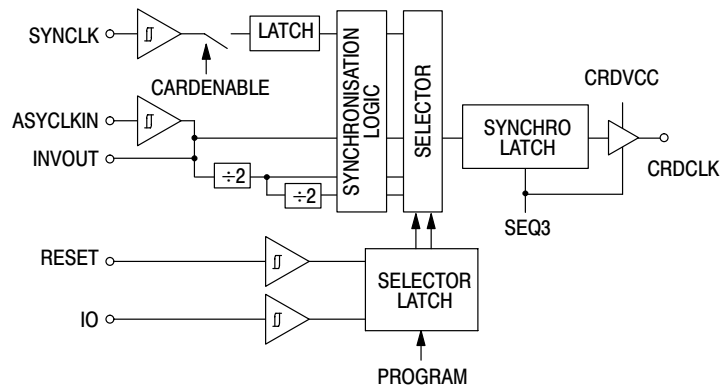

Figure 23. Clock Generator Functional Block



## BIDIRECTIONAL LEVEL TRANSLATOR

This module (used on **I/O/CRDIO**, **C4/CRDC4**, **C8/CRDC8**, Figure 24) adapts the signal voltage levels of the I/O and control lines between the micro controller (supplied by  $V_{BAT}$ ) and the smartcard (supplied by  $CRDV_{CC}$ )

When  $\overline{CS}$  is low, with  $CRDV_{CC}$  on, and start sequencing completed, this module is transparent for the data, and acts as if the card was directly connected to the reader microcontroller. The core of the level shifter circuit defined for the bidirectional **CRDIO**, **CRDC4** and **CRDC8** lines consists of a NMOS switch which can be driven to the logic low state from either side (microcontroller or card). If both sides work in transmission mode with opposite phase, then signal collision on the line is not avoidable. In this case, the peak current is limited to a safe value for the integrated circuit and the smartcard.

During high-to-low transitions, the NMOS transistor impedance ( $T1 = 250 \Omega$  maximum) is low enough to charge parasitic capacitance, and have a high enough dv/dt. On low to high transition, the NMOS transistor is not active above a certain voltage, and an acceleration circuit is activated to ensure a high dv/dt.

When the chip is disabled ( $\overline{CS} = H$ ) with the voltage supply  $CRDV_{CC}$  still active, the **I/O**, **C4** and **C8** lines keep their last logic state.

When the converter is off, a transistor forces the **CRDIO**, **CRDC4** and **CRDC8** lines to a low state, thus preventing any unwanted voltage level to be applied to the data lines when the card is not in use.

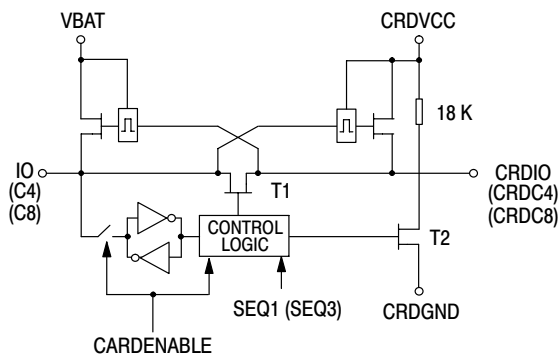

Figure 24. Bidirectional Translator Functional Block

## SECURITY FEATURES

The MC33560 has a number of unique security functions to guarantee that no electrical damage will be caused to the smartcard:

- Battery supply minimum voltage threshold
- Card supply undervoltage and overcurrent detection with automatic shutdown
- Card pin overvoltage clamp to  $CRDV_{CC}$

- Card presence detector for “clean” and fast shutdown
- Consistent card signal sequencing at startup and powerdown, according to ISO7816, even on error conditions
- Consistent clock signal, even when division ratio or synchronization clock signal are changed “on the fly” during a card session (Figure 29)
- Active pulldown on all card pins, including  $CRDV_{CC}$ , when not in normal operating mode.  
A current limiting function and an overtemperature detector are limiting power dissipation.

## ESD PROTECTION

Due to the nature of smartcards, the card interface pins must absorb high Electro Static Discharge (ESD) energy during card insertion. In addition, the control circuits attached to these pins must safely withstand short circuits and voltage transients during forced card extraction.

Therefore, the MC33560 features enhanced ESD protection, current limitation and short circuit protection on all smartcard interface pins, including **C4** and **C8**.

## PARALLEL OPERATION

For applications where two or more MC33560 are used, the digital control and data bus lines are common to all MC33560. Only the chip select signal,  $\overline{CS}$ , requires a separate line for each interface.

While deselected, all communication pins except **CRDCLK** will keep their logical state on the card side, and will go to high impedance mode on the microprocessor side.

Figure 31 shows a typical application of a dual card reader. This arrangement was chosen only to illustrate the parallel operation of two card interfaces in the same module. The discrete capacitor components are necessary to provide low impedance on the supply lines  $V_{BAT}$  and  $CRDV_{CC}$  and to suppress the high frequency noise due to the DC-DC converter. The load resistors are external in order to adapt the sense current of the “card present” switches.

## MINIMUM POWER CONSUMPTION CONSIDERATIONS

All analog blocks except the  $V_{BAT}$  comparator and the card presence detector are disabled in standby mode ( $\overline{CS} = H$ : DC-DC converter stopped).

In order to maintain standby current at a minimum value, all pins with pullup resistance ( $\overline{CS}$ ,  $\overline{INT}$ , **RDYMOD**) have to be kept in the high state or left open, and pins with pulldown resistance (**RESET**, **SYNCLK**, **PWRON**) have to be kept in the low state or left open. **ASYCLKIN** should not be connected to an active clock signal during standby to avoid dynamic currents. This is valid also for **SYNCLK**, except that it can be left open.

# MC33560

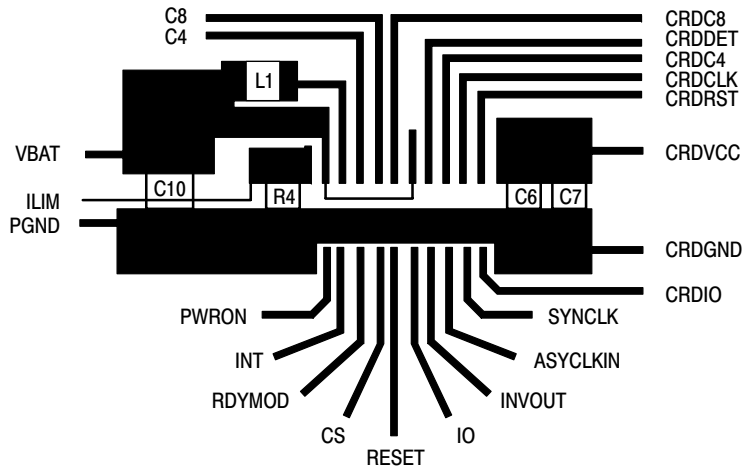
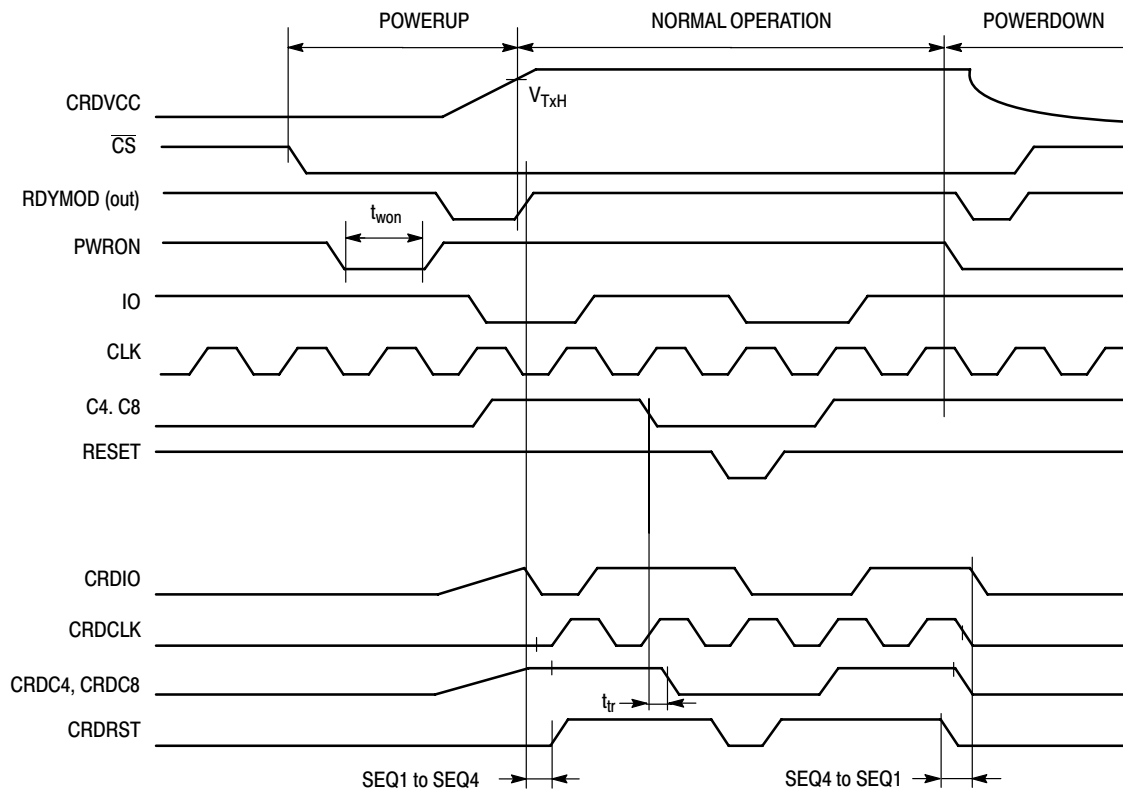
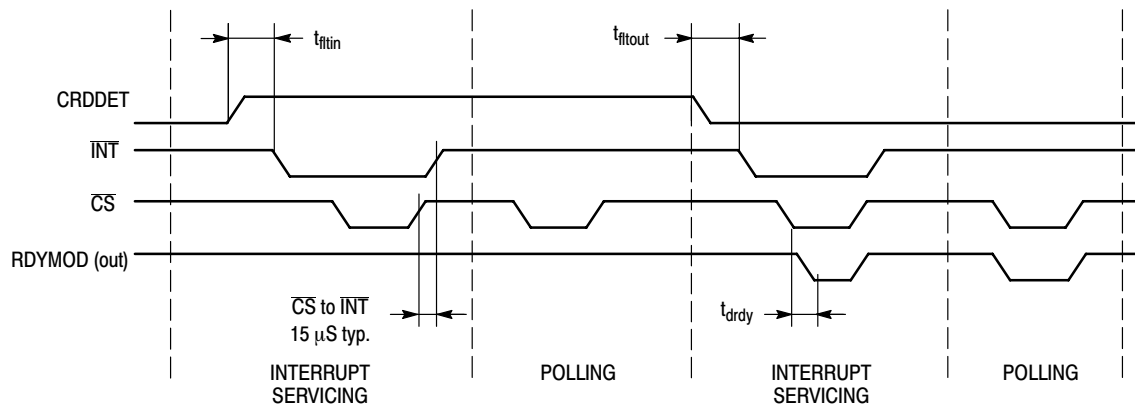

Figure 25. Example of Single Sided PCB Layout for MC33560

# MC33560



**Figure 26. Card Signal Sequence During  $V_{CC}$  Powerup/Down**



**Figure 27. Interrupt Servicing and Polling**

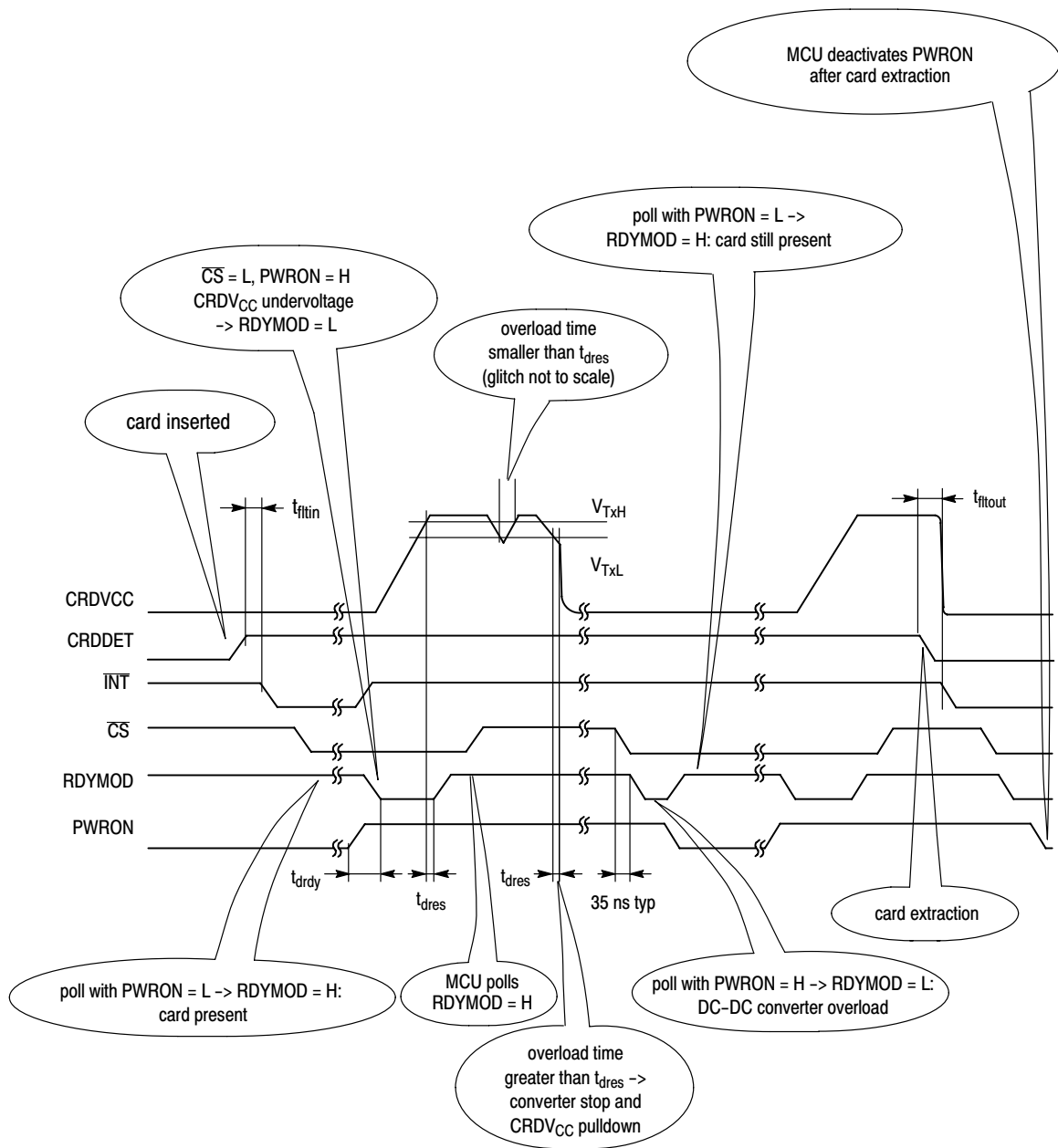

Figure 28. Card Signal Sequence During V<sub>CC</sub> Overload and Unexpected Card Extraction

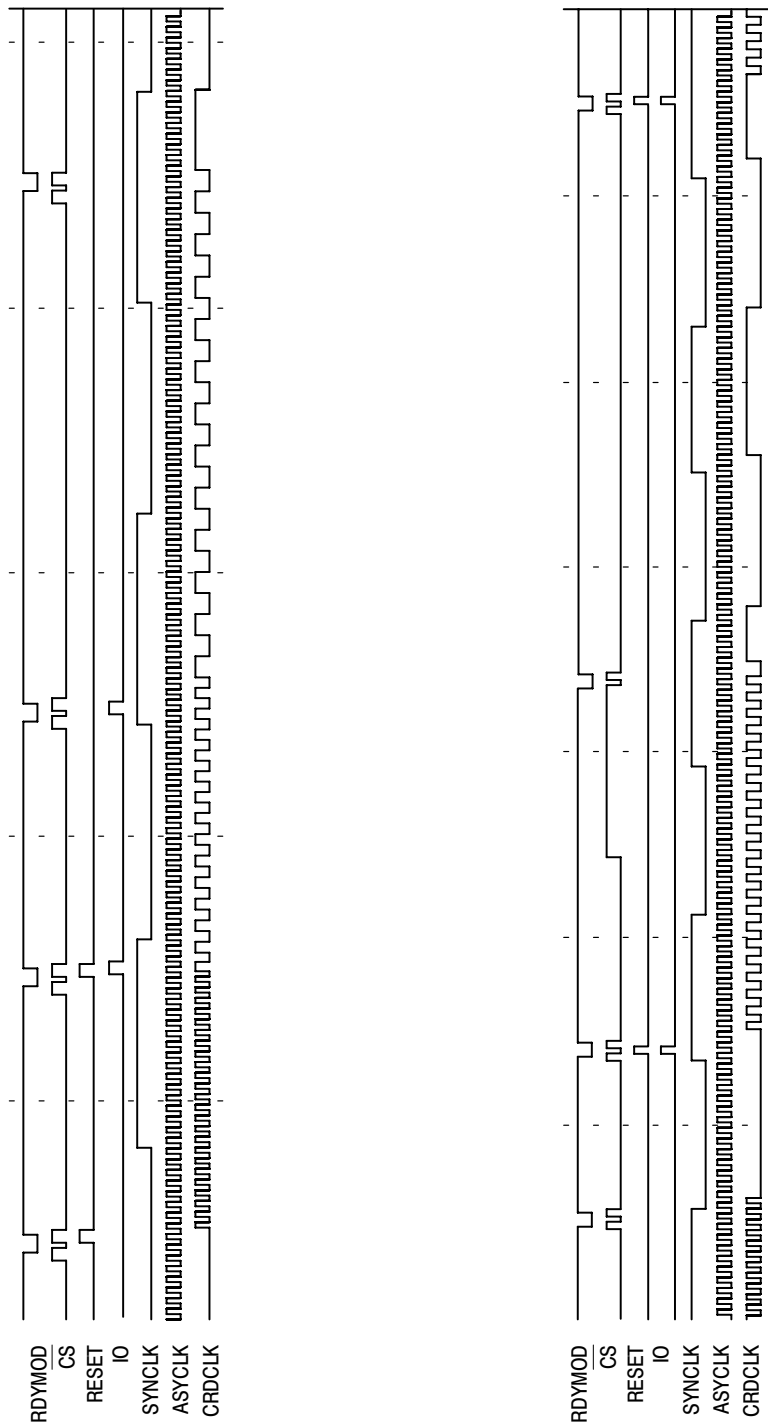

Figure 29. “On-the-Fly” Card Clock Selection Examples

# MC33560

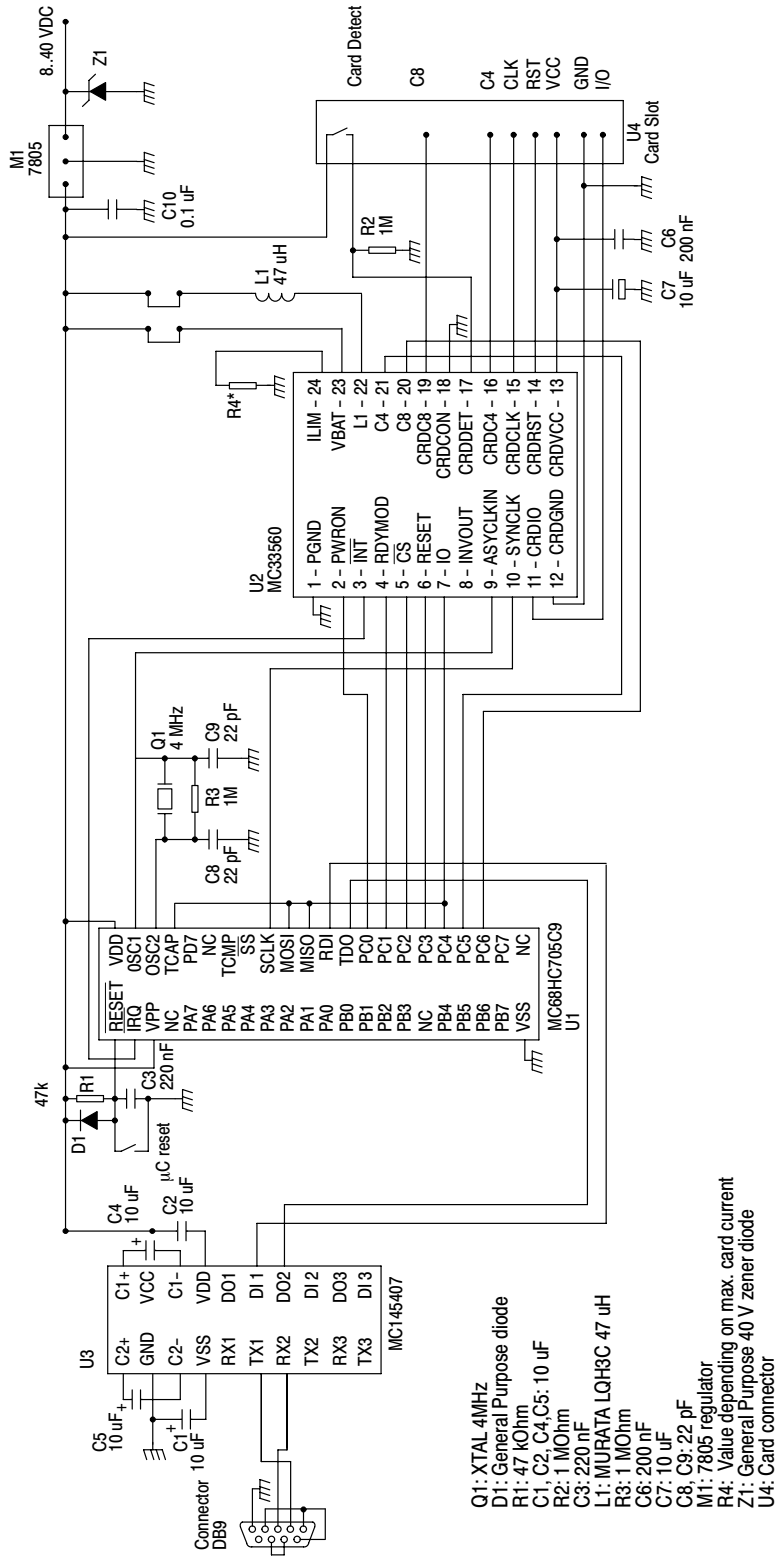

Figure 30. Card Reader/Writer Application

# MC33560

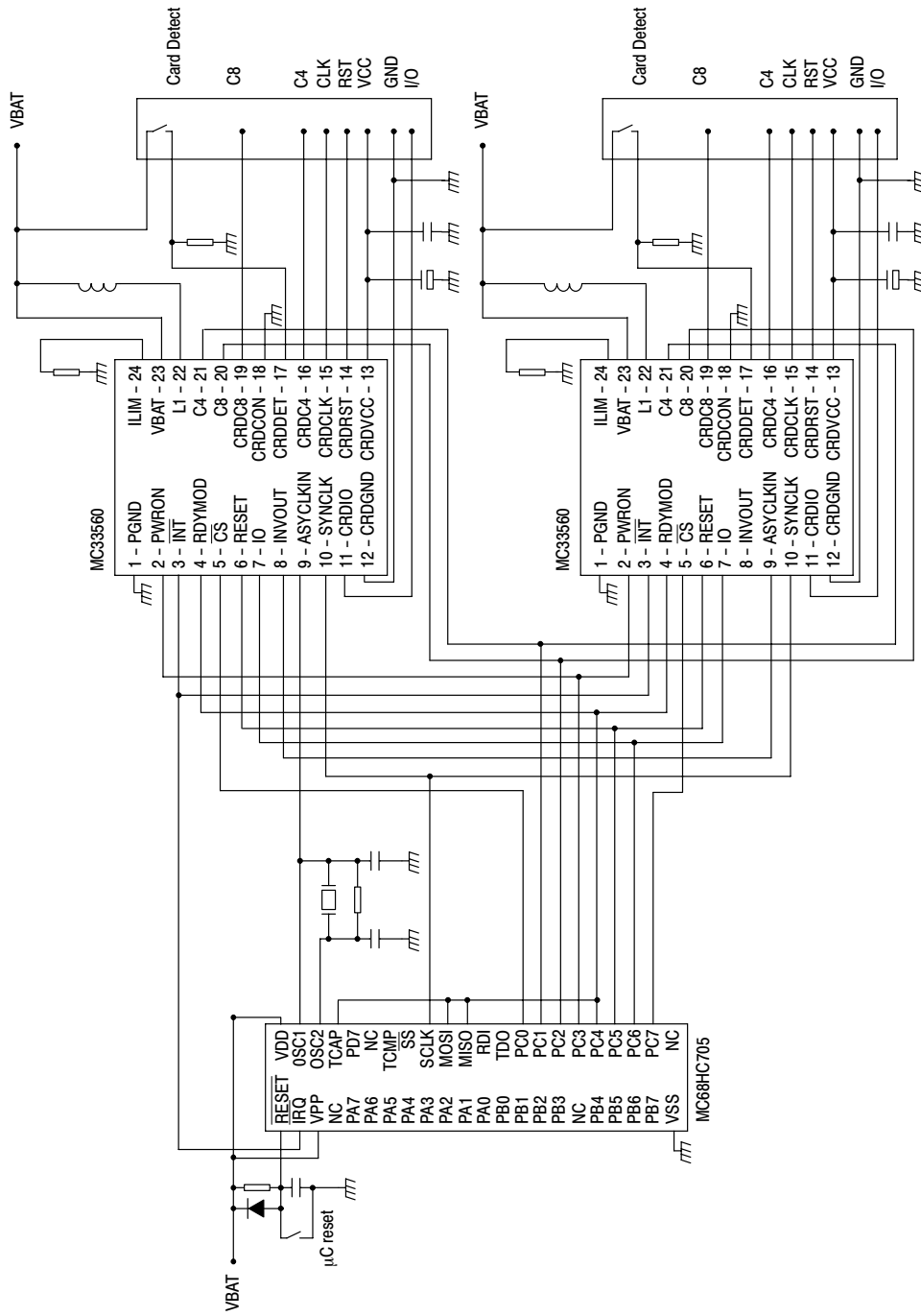

Figure 31. Multi Slot Card Reader/Writer Application

# MC33560

## ORDERING INFORMATION

Device	Package	Shipping†
MC33560DTB	TSSOP-24	62 Units / Rail
MC33560DTBR2	TSSOP-24	2500 / Tape & Reel
MC33560DTBR2G	TSSOP-24 (Pb-Free)	2500 / Tape & Reel
MC33560DW	SO-24	30 Units / Rail
MC33560DWR2	SO-24	1000 / Tape & Reel
MC33560DWR2G	SO-24 (Pb-Free)	1000 / Tape & Reel

†For information on tape and reel specifications, including part orientation and tape sizes, please refer to our Tape and Reel Packaging Specifications Brochure, BRD8011/D.



# MC33560

## PACKAGE DIMENSIONS

SO-24L  
DW SUFFIX  
PLASTIC PACKAGE  
CASE 751E-04  
ISSUE E

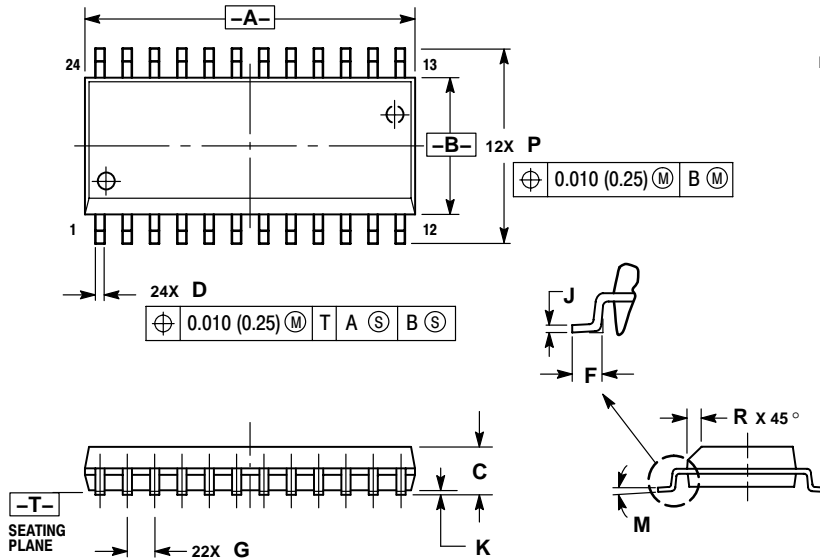

- NOTES:
1. DIMENSIONING AND TOLERANCING PER ANSI Y14.5M, 1982.
  2. CONTROLLING DIMENSION: MILLIMETER.
  3. DIMENSIONS A AND B DO NOT INCLUDE MOLD PROTRUSION.
  4. MAXIMUM MOLD PROTRUSION 0.15 (0.006) PER SIDE.
  5. DIMENSION D DOES NOT INCLUDE DAMBAR PROTRUSION. ALLOWABLE DAMBAR PROTRUSION SHALL BE 0.13 (0.005) TOTAL IN EXCESS OF D DIMENSION AT MAXIMUM MATERIAL CONDITION.

DIM	MILLIMETERS		INCHES	
	MIN	MAX	MIN	MAX
A	15.25	15.54	0.601	0.612
B	7.40	7.60	0.292	0.299
C	2.35	2.65	0.093	0.104
D	0.35	0.49	0.014	0.019
F	0.41	0.90	0.016	0.035
G	1.27 BSC		0.050 BSC	
J	0.23	0.32	0.009	0.013
K	0.13	0.29	0.005	0.011
M	0°	8°	0°	8°
P	10.05	10.55	0.395	0.415
R	0.25	0.75	0.010	0.029

# MC33560

## PACKAGE DIMENSIONS

TSSOP-24  
DTB SUFFIX  
PLASTIC PACKAGE  
CASE 948K-01  
ISSUE O

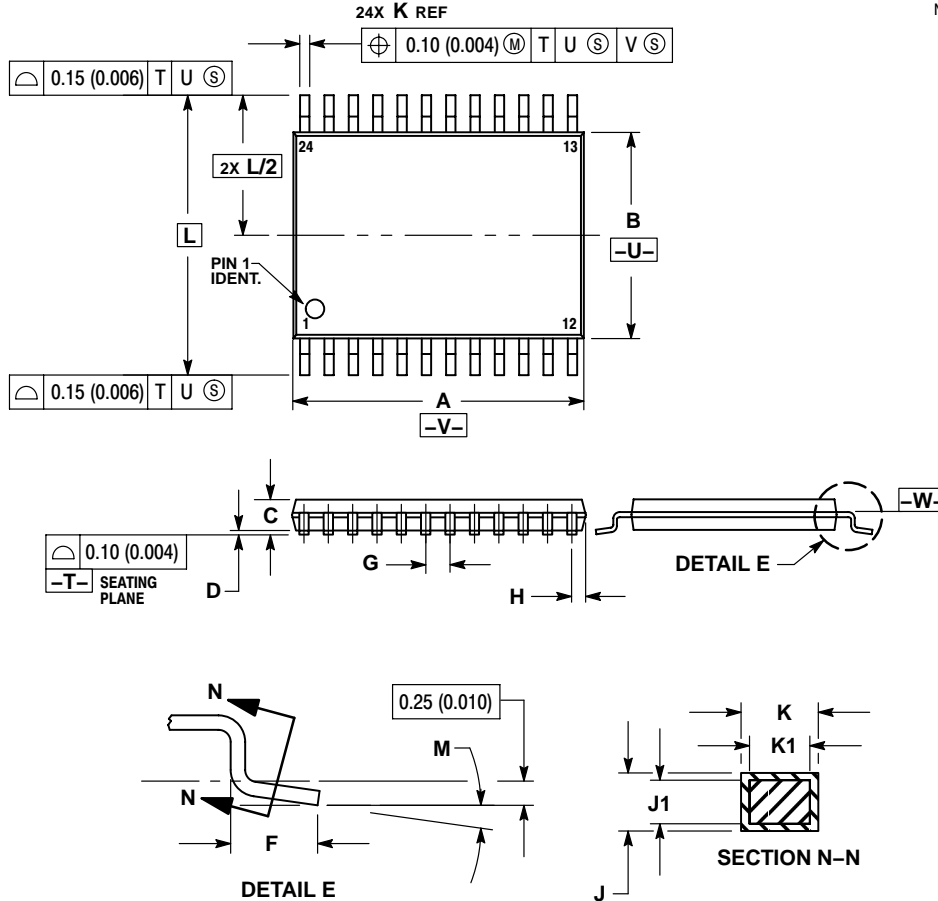

### NOTES:

1. DIMENSIONING AND TOLERANCING PER ANSI Y14.5M, 1982.
2. CONTROLLING DIMENSION: MILLIMETER.
3. DIMENSION A DOES NOT INCLUDE MOLD FLASH, PROTRUSIONS OR GATE BURRS. MOLD FLASH OR GATE BURRS SHALL NOT EXCEED 0.15 (0.006) PER SIDE.
4. DIMENSION B DOES NOT INCLUDE INTERLEAD FLASH OR PROTRUSION. INTERLEAD FLASH OR PROTRUSION SHALL NOT EXCEED 0.25 (0.010) PER SIDE.
5. DIMENSION K DOES NOT INCLUDE DAMBAR PROTRUSION. ALLOWABLE DAMBAR PROTRUSION SHALL BE 0.08 (0.003) TOTAL IN EXCESS OF THE K DIMENSION AT MAXIMUM MATERIAL CONDITION.
6. TERMINAL NUMBERS ARE SHOWN FOR REFERENCE ONLY.
7. DIMENSION A AND B ARE TO BE DETERMINED AT DATUM PLANE -W-.

DIM	MILLIMETERS		INCHES	
	MIN	MAX	MIN	MAX
A	7.70	7.90	0.303	0.311
B	5.50	5.70	0.216	0.224
C	---	1.20	---	0.047
D	0.05	0.15	0.002	0.006
F	0.50	0.75	0.020	0.030
G	0.65 BSC		0.026 BSC	
H	0.27	0.37	0.011	0.015
J	0.09	0.20	0.004	0.008
J1	0.09	0.16	0.004	0.006
K	0.19	0.30	0.007	0.012
K1	0.19	0.25	0.007	0.010
L	7.60 BSC		0.299 BSC	
M	0°	8°	0°	8°

ON Semiconductor and are registered trademarks of Semiconductor Components Industries, LLC (SCILLC). SCILLC reserves the right to make changes without further notice to any products herein. SCILLC makes no warranty, representation or guarantee regarding the suitability of its products for any particular purpose, nor does SCILLC assume any liability arising out of the application or use of any product or circuit, and specifically disclaims any and all liability, including without limitation special, consequential or incidental damages. "Typical" parameters which may be provided in SCILLC data sheets and/or specifications can and do vary in different applications and actual performance may vary over time. All operating parameters, including "Typicals" must be validated for each customer application by customer's technical experts. SCILLC does not convey any license under its patent rights nor the rights of others. SCILLC products are not designed, intended, or authorized for use as components in systems intended for surgical implant into the body, or other applications intended to support or sustain life, or for any other application in which the failure of the SCILLC product could create a situation where personal injury or death may occur. Should Buyer purchase or use SCILLC products for any such unintended or unauthorized application, Buyer shall indemnify and hold SCILLC and its officers, employees, subsidiaries, affiliates, and distributors harmless against all claims, costs, damages, and expenses, and reasonable attorney fees arising out of, directly or indirectly, any claim of personal injury or death associated with such unintended or unauthorized use, even if such claim alleges that SCILLC was negligent regarding the design or manufacture of the part. SCILLC is an Equal Opportunity/Affirmative Action Employer. This literature is subject to all applicable copyright laws and is not for resale in any manner.

### PUBLICATION ORDERING INFORMATION

**LITERATURE FULFILLMENT:**  
Literature Distribution Center for ON Semiconductor  
P.O. Box 61312, Phoenix, Arizona 85082-1312 USA  
**Phone:** 480-829-7710 or 800-344-3860 Toll Free USA/Canada  
**Fax:** 480-829-7709 or 800-344-3867 Toll Free USA/Canada  
**Email:** orderlit@onsemi.com

**N. American Technical Support:** 800-282-9855 Toll Free  
USA/Canada

**Japan:** ON Semiconductor, Japan Customer Focus Center  
2-9-1 Kamimeguro, Meguro-ku, Tokyo, Japan 153-0051  
**Phone:** 81-3-5773-3850

**ON Semiconductor Website:** <http://onsemi.com>

**Order Literature:** <http://www.onsemi.com/litorder>

For additional information, please contact your local Sales Representative.