

PF1510

Power management integrated circuit (PMIC) for low power application processors

Rev. 3 — 7 April 2020

Product data sheet

1 General description

The PF1510 is a power management integrated circuit (PMIC) designed specifically for use with i.MX processors on low-power portable, smart wearable and Internet-of-Things (IoT) applications. It is also capable of providing full power solution to i.MX 7ULP, i.MX 6SL, 6UL, 6ULL and 6SX processors.

With three high efficiency buck converters, three linear regulators, DDR reference and RTC supply, the PF1510 can provide power for a complete system, including application processors, memory, and system peripherals.

1.1 Features and benefits

This section summarizes the PF1510 features:

- Input voltage VIN from 5V bus, USB, or AC adapter (4.1 V to 6.0 V)
 - Linear front-end input LDO (1500 mA input limit)
 - Up to 6.5 V input operating range
 - VIN can withstand transient and DC inputs from 0 V up to +22 V
- Buck converters:
 - SW1, 1.0 A; 0.6 V to 1.3875 V in 12.5 mV steps, or 1.1 V to 3.3 V in variable steps
 - SW2, 1.0 A; 0.6 V to 1.3875 V in 12.5 mV steps, or 1.1 V to 3.3 V in variable steps
 - SW3, 1.0 A; 1.8 V to 3.3 V in 100 mV steps
 - Internal digital soft start
 - Quiescent current 1.0 μ A in ULP mode with light load
 - Peak efficiency > 90 %
 - Dynamic voltage scaling on SW1 and SW2
 - Modes: forced PWM quasi-fixed frequency mode, adaptive variable-frequency mode
 - Programmable output voltage, current limit and soft start
- LDO regulators
 - LDO1, 0.75 to 1.5 V/1.8 to 3.3 V, 300 mA with load switch mode
 - LDO2, 1.8 to 3.3 V, 400 mA
 - LDO3, 0.75 to 1.5 V/1.8 to 3.3 V, 300 mA with load switch mode
 - Quiescent current < 1.5 μ A in Low-power mode
 - Programmable output voltage
 - Soft start and ramp
 - Current limit protection
 - USB_PHY low dropout linear regulator
 - LDO2P7 always on regulator output
- LDO/switch supply
 - RTC supply VSNVS 3.0 V, 2.0 mA
 - Coin cell charger



Power management integrated circuit (PMIC) for low power application processors

- DDR memory reference voltage, VREFDDR, 0.5 to 0.9 V, 10 mA
- OTP (One time programmable) memory for device configuration
 - User programmable start-up sequence, timing, soft-start and power-down sequence
 - Programmable regulator output voltages
- I²C interface
- User programmable Standby, Sleep/Low-power, and Off (REGS_DISABLE) modes
- Ambient temperature range -40 °C to 105 °C

1.2 Applications

- Low-power IoT applications
- Wireless game controllers
- Embedded monitoring systems
- Home automation
- POS
- E-Reader
- Smart mobile/wearable devices

2 Application diagram

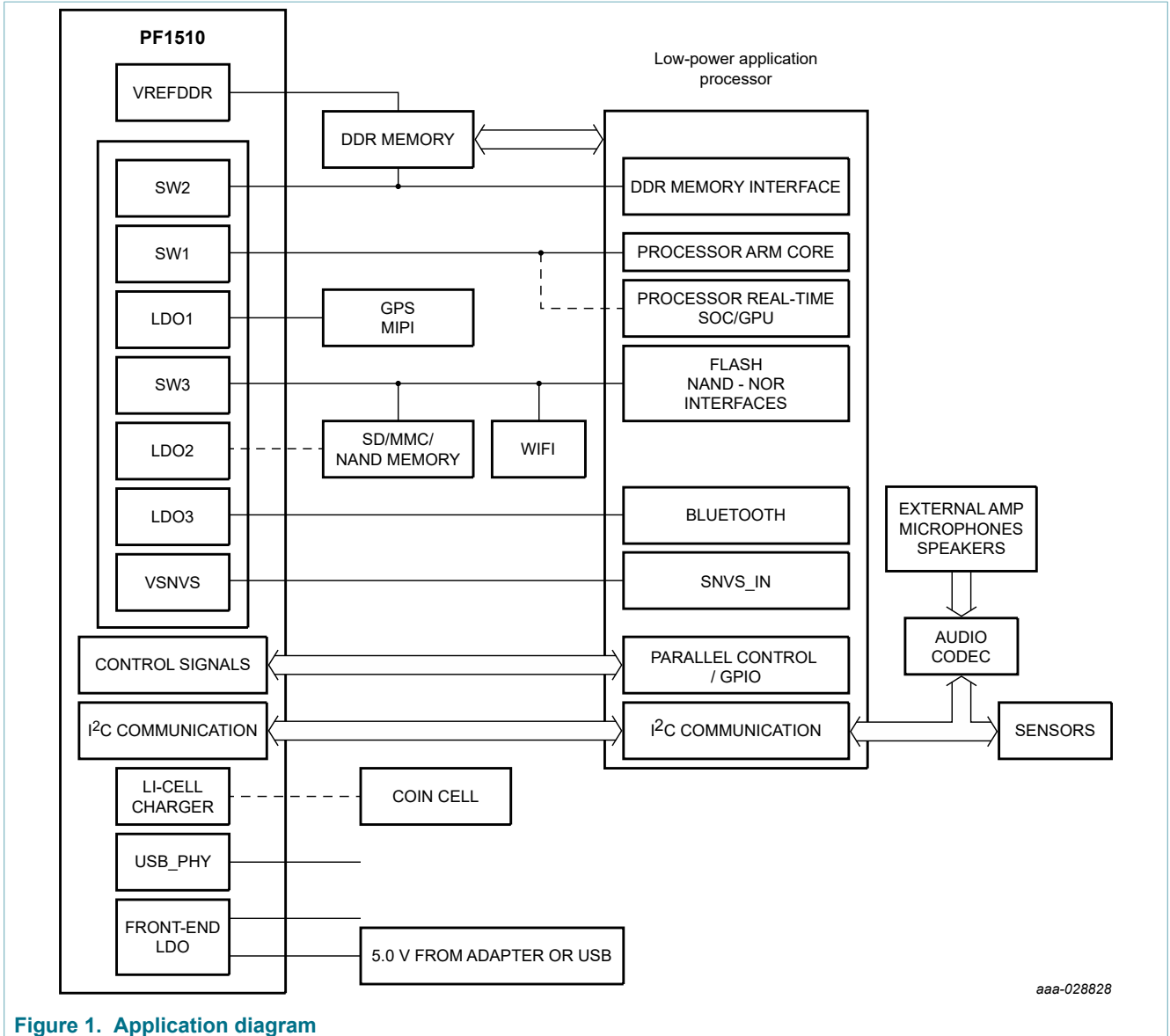

Figure 1. Application diagram

2.1 Functional block diagram

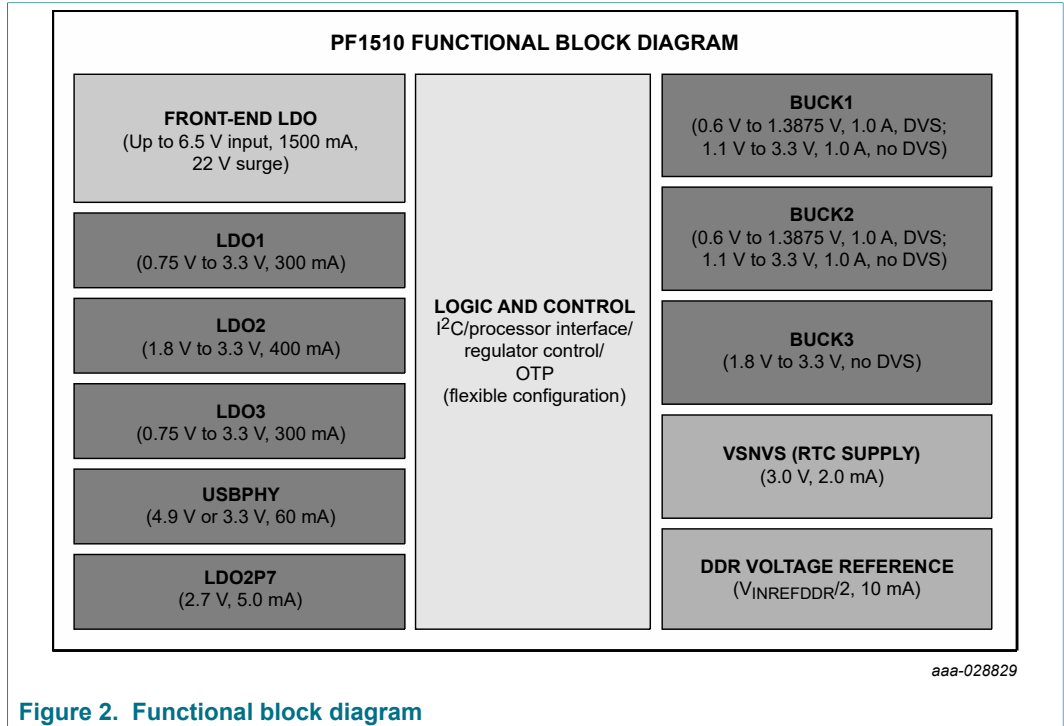

Figure 2. Functional block diagram

2.2 Internal block diagram

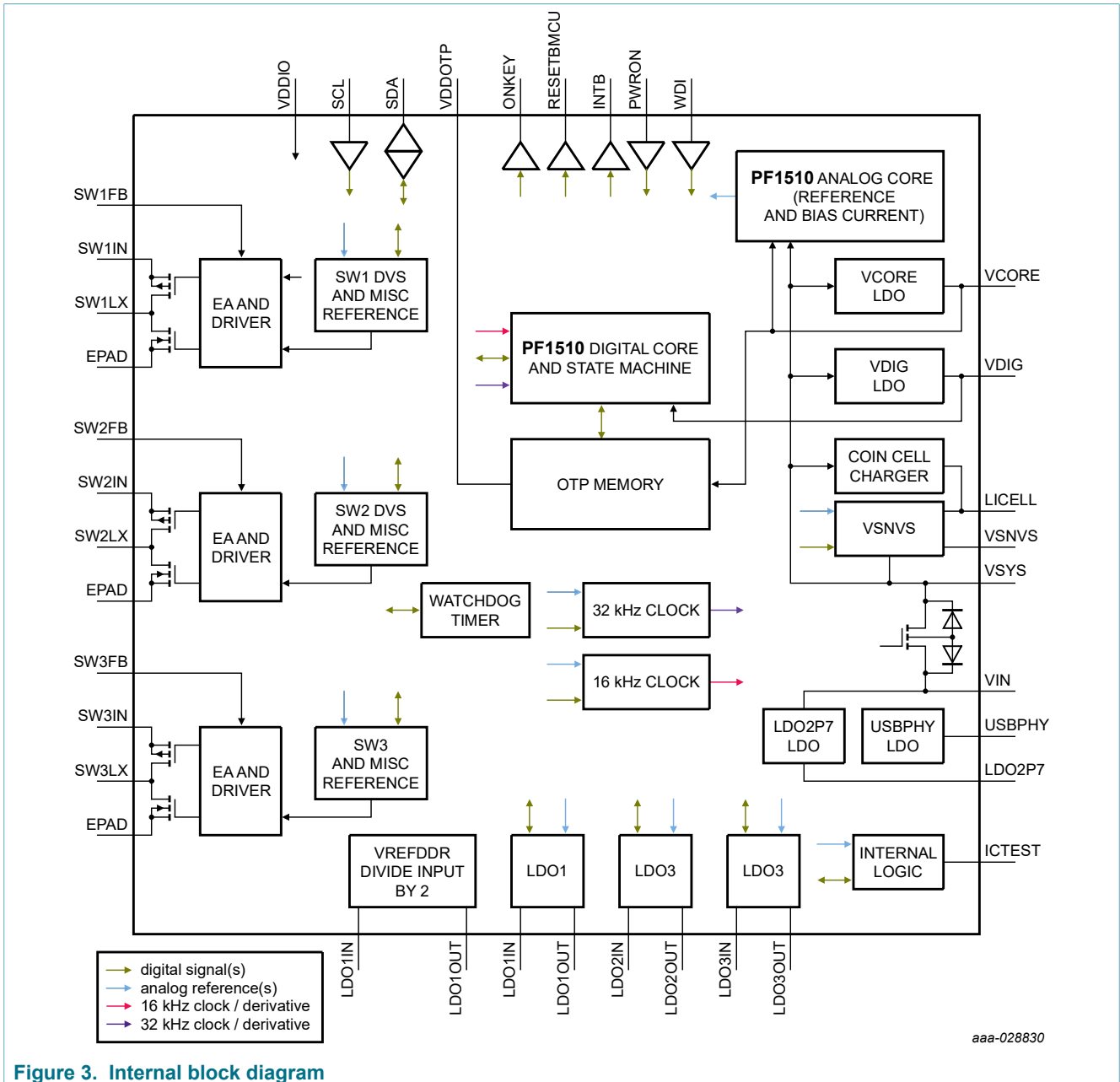

Figure 3. Internal block diagram

3 Orderable parts

The PF1510 is available only with preprogrammed configurations. These preprogrammed devices are identified using the program codes from [Table 1](#), which also list the associated NXP reference designs where applicable. Details of the OTP programming for each device can be found in [Table 53](#).

Power management integrated circuit (PMIC) for low power application processors

Table 1. Orderable part variations

Part number ^[1]	Temperature (T _A)	Package	Programming options
MC32PF1510A0EP	-40 °C to 85 °C (for use in consumer applications)	98ASA00913D, 40-pin QFN 5.0 mm x 5.0 mm with exposed pad	0 - not programmed
MC32PF1510A1EP			1 (Default)
MC32PF1510A2EP			2 (i.MX 7ULP with LPDDR3) ^[2]
MC32PF1510A3EP			3 (i.MX 6UL with DDR3L)
MC32PF1510A4EP			4 (i.MX 7ULP with LPDDR3)
MC32PF1510A5EP			5 (i.MX 6UL with DDR3)
MC32PF1510A6EP			6 (i.MX 6ULL with DDR3L)
MC32PF1510A7EP			7 (i.MX 6UL with LPDDR2)
MC34PF1510A0EP	-40 °C to 105 °C (for use in industrial applications)		0 - not programmed
MC34PF1510A1EP			1 (Default)
MC34PF1510A2EP			2 (i.MX 7ULP with LPDDR3) ^[2]
MC34PF1510A3EP			3 (i.MX 6UL with DDR3L)
MC34PF1510A4EP			4 (i.MX 7ULP with LPDDR3)
MC34PF1510A5EP			5 (i.MX 6UL with DDR3)
MC34PF1510A6EP		6 (i.MX 6ULL with DDR3L)	
MC34PF1510A7EP		7 (i.MX 6UL with LPDDR2)	

[1] For tape and reel, add an R2 suffix to the part number.

[2] For internal validation only

4 Pinning information

4.1 Pinning

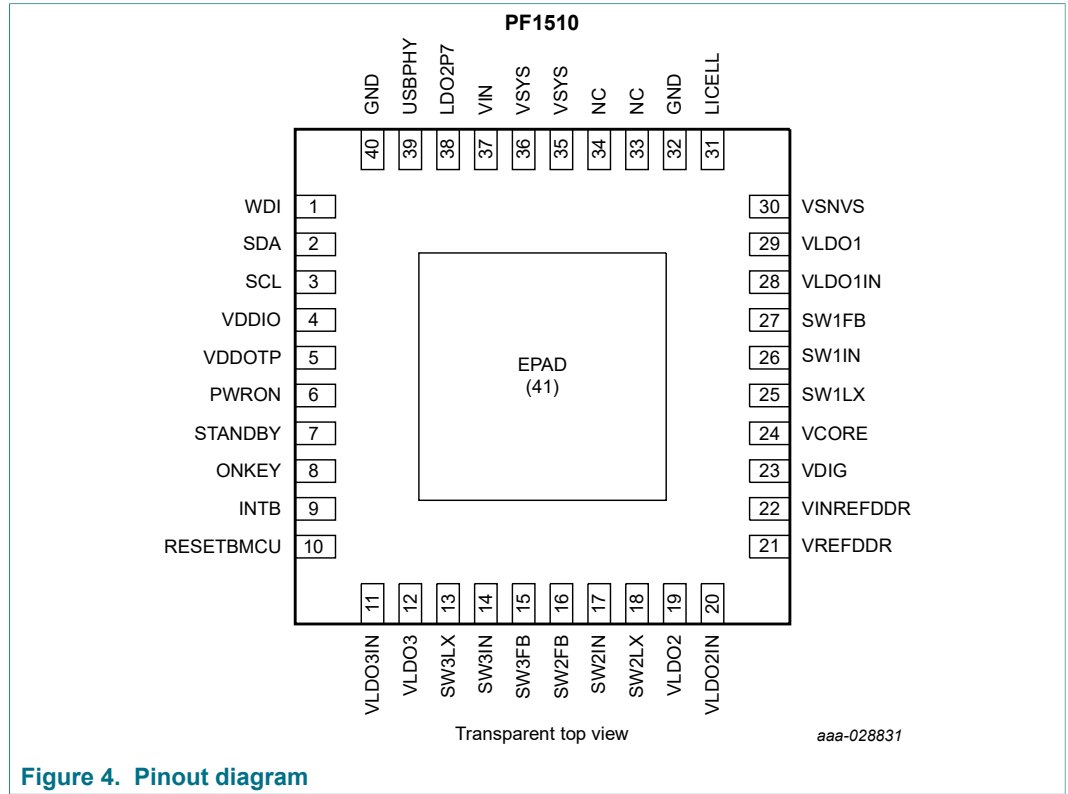

Figure 4. Pinout diagram

4.2 Pin definitions

Table 2. Pin description

Pin number	Block	Pin name	Recommended connection	Recommended connection when not used
1	WDI	Watchdog input from processor	Connect to WDI signal from processor. Pull up via 8 kΩ - 100 kΩ to VDDIO	Connect via 100 kΩ to regulator with output voltage < 3.6 V
2	SDA	I ² C data line	Pull-up to VDDIO	Leave floating
3	SCL	I ² C clock line	Pull-up to VDDIO	Leave floating
4	VDDIO	Supply for I ² C bus	Connect to 1.7 to 3.6 V supply. Bypass with 0.1 μF capacitor to ground	Leave floating
5	VDDOTP	Supply to program OTP fuses	Connect to ground for the fuse loading	N/A
6	PWRON	Power On/Off from processor	Connect to PMIC_ON_REQ from processor. Pull up via 8 kΩ - 100 kΩ to VSNVS if required	N/A
7	STANDBY	Standby input signal from processor	Connect to PMIC_STBY_REQ signal from processor	Connect to ground
8	ONKEY	ONKEY push button input	Connect to push button and pull up via 8kΩ - 100 kΩ to VIN	Connect via 100 kΩ to VSYS
9	INTB	Open drain interrupt signal to processor	Pull-up via 68 kΩ - 100 kΩ to VSNVS or other rail at voltage less than or equal to VDDIO	Leave floating
10	RESETBMCU	Open drain reset output to processor	Pull-up via 68 kΩ - 100 kΩ to VSNVS or other rail at voltage less than or equal to VDDIO	Leave floating
11	VLDO3IN	LDO3 regulator input	Connect to VSYS and bypass with 1.0 mF capacitor to ground	Connect to regulator with output voltage < 4.5 V
12	VLDO3	LDO3 regulator output	Bypass with 4.7 μF capacitor to ground	Leave floating
13	SW3LX	SW3 switching node	Connect to SW3 inductor	Leave floating
14	SW3IN	Input to SW3 regulator	Connect to VSYS and bypass with 0.1 μF + 4.7 μF capacitors to ground	Connect to VSYS
15	SW3FB	Output voltage feedback for SW3	Connect to SW3 output voltage rail near load	Leave floating
16	SW2FB	Output voltage feedback for SW2	Connect to SW2 output voltage rail near load	Leave floating
17	SW2IN	Input to SW2 regulator	Connect to VSYS and bypass with 0.1 μF + 4.7 μF capacitors to ground	Connect to VSYS
18	SW2LX	SW2 switching node	Connect to SW2 inductor	Leave floating
19	VLDO2	LDO2 regulator output	Bypass with 10 μF capacitor to ground	Leave floating
20	VLDO2IN	LDO2 regulator input	Connect to VSYS and bypass with 1.0 mF capacitor to ground	Connect to regulator with output voltage < 4.5 V
21	VREFDDR	VREFDDR regulator output	Bypass with 1.0 μF capacitor to ground	Leave floating
22	VINREFDDR	VREFDDR regulator input	Ensure there is at least 1.0 μF net capacitance from VINREFDDR to ground	Leave floating
23	VDIG	Digital core supply	Bypass with 1.0 μF capacitor to ground	N/A
24	VCORE	Analog core supply	Bypass with 1.0 μF capacitor to ground	N/A
25	SW1LX	SW1 switching node	Connect to SW1 inductor	Leave floating
26	SW1IN	Input to SW1 regulator	Connect to VSYS and bypass with 0.1 μF + 4.7 μF capacitors to ground	Connect to VSYS
27	SW1FB	Output voltage feedback for SW1	Connect to SW1 output voltage rail near load	Leave floating
28	VLDO1IN	LDO1 regulators input	Connect to VSYS and bypass with 1.0 μF capacitor to ground	Connect to regulator with output voltage < 4.5 V
29	VLDO1	LDO1 regulator output	Bypass with 4.7 μF capacitor to ground	Leave floating

Power management integrated circuit (PMIC) for low power application processors

Pin number	Block	Pin name	Recommended connection	Recommended connection when not used
30	VSNVS	VSNVS regulator/switch output	Bypass with 0.47 μ F capacitor to ground	Bypass with 0.47 μ F capacitor to ground
31	LICELL	Coin cell supply input/output	Bypass with 0.1 μ F capacitor. Connect to optional coin cell.	Bypass with 0.1 μ F capacitor to ground
32	GND	Ground	Connect to ground	Connect to ground
33	NC	Not connected	Not connected	Leave floating
34	NC			
35	VSYS	Main input voltage to PMIC	Bypass with 2x 22 μ F/10 V capacitors or a 47 μ F/10 V capacitor to ground	N/A
36	VSYS			
37	VIN	Main IC supply	Connect to a valid 5.0 V input, bypass with a 2.2 μ F/25 V capacitor to ground	Leave floating
38	LDO2P7	LDO2P7 regulator output	Bypass with 2.2 μ F capacitor to ground mandatory	Bypass with 2.2 μ F capacitor to ground mandatory
39	USBPHY	USBPHY regulator output	Bypass with 1.0 μ F capacitor to ground	Leave floating
40	GND	Ground	Connect to ground	Connect to ground
—	EP	Expose pad. Functions as ground return for buck and boost regulators	Ground. Connect this pad to the inner and external ground planes through multiple vias to allow effective thermal dissipation.	N/A

5 General product characteristics

5.1 Thermal characteristics

Table 3. Thermal ratings

Symbol	Description (Rating)	Min	Max	Unit
THERMAL RATINGS				
T_A	Ambient operating temperature range (industrial) Ambient operating temperature range (consumer)	-40 -40	105 85	$^{\circ}$ C
T_J	Operating junction temperature range	[1] -40	125	$^{\circ}$ C
T_{ST}	Storage temperature range	-65	150	$^{\circ}$ C
T_{PPRT}	Peak package reflow temperature	[2] [3] —	—	$^{\circ}$ C
QFN40 THERMAL RESISTANCE AND PACKAGE DISSIPATION RATINGS				
$R_{\theta JA}$	Junction to ambient thermal resistance, natural convection Four layer board (2s2p) Six layer board (2s4p) Eight layer board (2s6p)	[4] [5] [6] —	27 20.6 17.8	$^{\circ}$ C/W
$R_{\theta JMA}$	Junction to ambient (@200ft/min) Four layer board (2s2p)	[4] [6] —	21.4	$^{\circ}$ C/W
$R_{\theta JB}$	Junction to board	[7] —	8.8	$^{\circ}$ C/W
$R_{\theta JCBOTTOM}$	Junction to case bottom	[8] —	1.4	$^{\circ}$ C/W
Ψ_{JT}	Junction to package top – Natural convection	[9] —	0.6	$^{\circ}$ C/W

[1] Do not operate beyond 125 $^{\circ}$ C for extended periods of time. Operation above 150 $^{\circ}$ C may cause permanent damage to the IC. See Thermal Protection Thresholds for thermal protection features.

[2] Pin soldering temperature limit is for 10 seconds maximum duration. Not designed for immersion soldering. Exceeding these limits may cause a malfunction or permanent damage to the device.

Power management integrated circuit (PMIC) for low power application processors

- [3] NXP's package reflow capability meets Pb-free requirements for JEDEC standard J-STD-020C. For peak package reflow temperature and moisture sensitivity levels (MSL), go to <http://www.nxp.com>, search by part number [remove prefixes/suffixes and enter the core ID to view all orderable parts (for MC33xxxD enter 33xxx), and review parametrics.
- [4] Junction temperature is a function of die size, on-chip power dissipation, package thermal resistance, mounting site (board) temperature, ambient temperature, air flow, power dissipation of other components on the board, and board thermal resistance.
- [5] The Board uses the JEDEC specifications for thermal testing (and simulation) JESD51-7 and JESD51-5.
- [6] Per JEDEC JESD51-6 with the board horizontal.
- [7] Thermal resistance between the die and the printed circuit board per JEDEC JESD51-8. Board temperature is measured on the top surface of the board near the package.
- [8] Thermal resistance between the die and the case top surface as measured by the cold plate method (MIL SPEC-883 Method 1012.1).
- [9] Thermal characterization parameter indicating the temperature difference between package top and the junction temperature per JEDEC JESD51-2. When Greek letters are not available, the thermal characterization parameter is written as Psi-JT.

5.2 Absolute maximum ratings

Table 4. Maximum ratings

Symbol	Description (Rating)	Min	Max	Unit
I/Os				
VIN	Main IC supply	-0.3	24	V
VDDIO	I/O supply voltage. Connect to voltage rail between 1.7 V and 3.3 V.	-0.3	3.6	V
SCL	SCL when used in I ² C mode. SCLK when used in SPI mode.	-0.3	3.6	V
SDA	SDA when used in I ² C mode. MISO when used in SPI mode.	-0.3	3.6	V
RESETBMCU	RESETBMCU open drain output	-0.3	3.6	V
PWRON	PWRON input	-0.3	3.6	V
STANDBY	STANDBY input	-0.3	3.6	V
ONKEY	ONKEY push button input	-0.3	4.8	V
INTB	INTB open-drain output	-0.3	3.6	V
WDI	Watchdog input from processor	-0.3	3.6	V
VDDOTP				
VDDOTP	Connect to ground in the application	-0.3	10	V
BUCK 1				
SW1IN	Buck 1 input supply	-0.3	4.8	V
SW1LX	Buck 1 switching node	-0.3	4.8	V
SW1FB	Buck 1 feedback input	-0.3	3.6	V
BUCK 2				
SW2IN	Buck 2 input supply	-0.3	4.8	V
SW2LX	Buck 2 switching node	-0.3	4.8	V
SW2FB	Buck 2 output voltage feedback	-0.3	3.6	V
BUCK 3				
SW3IN	Buck 3 input supply	-0.3	4.8	V
SW3LX	Buck 3 switching node	-0.3	4.8	V
SW3FB	Buck 3 output voltage feedback	-0.3	3.6	V
LDO1				
VLDO1IN	LDO1 input supply	-0.3	4.8	V
VLDO1	LDO1 output	-0.3	3.6	V

Power management integrated circuit (PMIC) for low power application processors

Symbol	Description (Rating)	Min	Max	Unit
LDO2				
VLDO2IN	LDO2 input supply	-0.3	4.8	V
VLDO2	LDO2 output	-0.3	3.6	V
LDO3				
VLDO3IN	LDO3 input supply	-0.3	4.8	V
VLDO3	LDO3 output	-0.3	3.6	V
VSNVS				
VSNVS	VSNVS regulator output	-0.3	3.6	V
LICELL	Coin cell input	-0.3	3.6	V
FRONT-END LDO				
LDO2P7	LDO2P7 regulator output	-0.3	3.6	V
USBPHY	USBPHY regulator output	-0.3	5.5	V
INPUT/OUTPUT SUPPLY				
VINREFDDR	VREFDDR input supply	-0.3	3.6	V
VREFDDR	VREFDDR output	-0.3	3.6	V
IC CORE				
VSYS	Main input voltage to PMIC	-0.3	4.8	V
VDIG	VDIG regulator output (used within PF1510)	-0.3	1.65	
VCORE	VCORE regulator output (used within PF1510)	-0.3	1.65	V
ELECTRICAL RATINGS				
V _{ESD}	ESD ratings	[1]		
	Human body model		—	±2000
	Charge device model (corner pins)		—	±750
	Charge device model (all other pins)		—	±500

[1] Testing is performed in accordance with the human body model (HBM) ($C_{ZAP} = 100$ pF, $R_{ZAP} = 1500$ Ω), and the charge device model (CDM), Robotic ($C_{ZAP} = 4.0$ pF).

5.3 Electrical characteristics

5.3.1 Electrical characteristics – Front-end LDO

All parameters are specified at $T_A = -40$ to 105 °C, $V_{IN} = 5.0$ V, $V_{SYS} = 3.7$ V, typical external component values, unless otherwise noted. Typical values are characterized at $V_{IN} = 5.0$ V, $V_{SYS} = 3.7$ V and 25 °C, unless otherwise noted.

Table 5. Front-end LDO

Symbol	Parameter	Measurement condition	Min	Typ	Max	Unit
FRONT-END LDO INPUT						
V_{IN}	VIN voltage range	Operating voltage	V_{UVLO}	—	V_{OVLO}	V
$V_{IN_WITHSTAND}$	VIN maximum withstand voltage rating		—	—	22	V
V_{IN_OVLO}	VIN overvoltage threshold	Rising	6.0	6.5	7.0	V
V_{OVLO_HYS}	VIN overvoltage threshold hysteresis	Falling	50	150	250	mV
t_{D-OVLO}	VIN overvoltage delay		5.0	10	15	μs
V_{UVLO}	VIN to GND minimum turn on threshold accuracy	VIN rising	3.8	4.0	4.2	V
$V_{UVLO-HYS}$	VIN UVLO hysteresis		400	500	600	mV
V_{IN2SYS_50}	VIN to VSYS minimum turn on threshold accuracy	VIN rising, 50 mV setting	20	50	80	mV
V_{IN2SYS_175}	VIN to VSYS minimum turn on threshold accuracy	VIN rising, 175 mV setting	100	175	250	mV

Table 6. Input currents

Symbol	Parameter	Measurement condition	Min	Typ	Max	Unit
VIN CURRENT LIMIT						
I_{LIM10}	VIN current limit (10 mA settings)	10 mA	6.0	8.5	11	mA
I_{LIM15}	VIN current limit (15 mA settings)	15 mA	10.5	12.75	16	mA
I_{LIM20}	VIN current limit (20 mA settings)	20 mA	14	17	21	mA
I_{LIM25}	VIN current limit (25 mA settings)	25 mA	17.5	21.25	26	mA
I_{LIM30}	VIN current limit (30 mA setting)	30 mA	21	25.5	30	mA
I_{LIM35}	VIN current limit (35 mA settings)	35 mA	24.5	29.75	35	mA
I_{LIM40}	VIN current limit (40 mA settings)	40 mA	28	34	40	mA
I_{LIM45}	VIN current limit (45 mA settings)	45 mA	31.5	38.25	45	mA
I_{LIM50}	VIN current limit (50 mA settings)	50 mA	35	42.5	50	mA
I_{LIM100}	VIN current limit (100 mA settings)	100 mA	85	95	105	mA
I_{LIM150}	VIN current limit (150 mA settings)	150 mA	125	137.5	160	mA
I_{LIM200}	VIN current limit (200 mA settings)	200 mA	170	190	210	mA
I_{LIM300}	VIN current limit (300 mA setting)	300 mA	260	285	320	mA
I_{LIM400}	VIN current limit (400 mA settings)	400 mA	345	380	425	mA

Power management integrated circuit (PMIC) for low power application processors

Symbol	Parameter	Measurement condition	Min	Typ	Max	Unit
ILIM ₅₀₀	VIN current limit (500 mA settings)	500 mA	430	475	530	mA
ILIM ₆₀₀	VIN current limit (600 mA settings)	600 mA	520	570	640	mA
ILIM ₇₀₀	VIN current limit (700 mA settings)	700 mA	610	665	750	mA
ILIM ₈₀₀	VIN current limit (800 mA settings)	800 mA	690	760	850	mA
ILIM ₉₀₀	VIN current limit (900 mA settings)	900 mA	780	855	950	mA
ILIM ₁₀₀₀	VIN current limit (1000 mA settings)	1000 mA	855	950	1100	mA
ILIM ₁₅₀₀	VIN current limit (1500 mA settings)	1500 mA	1260	1400	1700	mA
R _{INSD}	Input self discharge resistance		18	30	42	kΩ

Table 7. Switch impedances and leakage currents

Symbol	Parameter	Measurement Condition	Min	Typ	Max	Unit
R _{VIN2SYS}	VIN to VSYS resistance		100	250	550	mΩ
I _{SYS}	VSYS leakage current	VSYS = 0 V	0	0.2	10	μA

Table 8. Watchdog timer

Symbol	Parameter	Measurement condition	Min	Typ	Max	Unit
t _{WD}	Watchdog timer period		—	80	—	s
t _{WDACC}	Watchdog timer accuracy		-20	0	20	%

Table 9. Internal 2.7 V Regulator (LDO2P7)

Symbol	Parameter	Measurement condition	Min	Typ	Max	Unit
V _{GDRV}	Output voltage		2.6	2.7	2.8	V
I _{GDRV}	Output current		5.0	—	—	mA
V _{DO(GDRV)}	Dropout voltage		0	—	800	mV

Table 10. USBPHY LDO

Symbol	Parameter	Measurement condition	Min	Typ	Max	Unit
V _{USB_PHY}	Output voltage	I _{OUT} = 10 mA; 3.3 V and 4.9 V settings. VIN = 5.5 V	-5.0	—	5.0	%
I _{USB_PHY}	Maximum output current		60	—	—	mA
USB _{RDIS}	Internal discharge resistance		500	1000	1500	Ω
USB _{CAPSTA}	Output capacitor for stable operation	0 μA < I _{OUT} < 60 mA, MAX ESR = 10 mΩ	0.7	1.0	2.2	μF
I _{QUSB}	Quiescent supply current		—	35	—	μA
USBPHY _{LDREG}	DC load regulation	VIN = 5.5 V, 30 μA < I _{OUT} < 60 mA	0	5.0	13	mV

Symbol	Parameter	Measurement condition	Min	Typ	Max	Unit
USBPHY _{DO}	Dropout voltage	V _{IN} = 5.0 V, I _{OUT} = 60 mA	—	200	350	mV
USBPHY _{LIM}	Output current limit		65	150	200	mA
PSRR _{USB_PHY}	PSRR	V _{IN} = 5.5 V, C _{OUT} = 1.0 μF	55	60	75	dB

5.3.2 Electrical characteristics – SW1 and SW2

All parameters are specified at T_A = -40 to 105 °C, V_{SYS} = V_{SWxIN} = 2.5 to 4.5 V, V_{SWx} = 1.2 V, I_{SWx} = 200 mA, typical external component values, f_{SWx} = 2.0 MHz, unless otherwise noted. Typical values are characterized at V_{SYS} = V_{SWxIN} = 3.6 V, V_{SWx} = 1.1 V, I_{SWx} = 100 mA, and 25 °C, unless otherwise noted.

Table 11. SW1 and SW2 electrical characteristics

Symbol	Parameter	Min	Typ	Max	Unit
V _{SWxIN}	Operating input voltage	2.5	—	4.5	V
I _{SWx}	Rated output current	1000	—	—	mA
V _{SWx}	Output voltage accuracy DVS enabled mode (OTP_SWx_DVS_SEL = 0) Normal power mode, 2.5 V < V _{SWxIN} < 4.5 V, 0 < I _{SWx} < 1.0 A 0.6 V ≤ V _{SWx} ≤ 1.0 V	-15	—	15	mV
V _{SWx}	Output voltage accuracy DVS enabled mode (OTP_SWx_DVS_SEL = 0) Normal power mode, 2.5 V < V _{SWxIN} < 4.5 V, 0 < I _{SWx} < 1.0 A 1.0 V < V _{SWx} ≤ 1.3875 V	-2.0	—	2.0	%
V _{SWx}	Output voltage accuracy DVS enabled mode (OTP_SWx_DVS_SEL = 0) Low-power mode, 2.5 V < V _{SWxIN} < 4.5 V, 0 < I _{SWx} < 0.1 A 0.6 V ≤ V _{SWx} ≤ 1.0 V	-30	—	30	mV
V _{SWx}	Output voltage accuracy DVS enabled mode (OTP_SWx_DVS_SEL = 0) Low-power mode, 2.5 V < V _{SWxIN} < 4.5 V, 0 < I _{SWx} < 0.1 A 1.0 V < V _{SWx} ≤ 1.3875 V	-3.0	—	3.0	%
V _{SWx}	Output voltage accuracy DVS disabled mode (OTP_SWx_DVS_SEL = 1) Normal power mode, 2.5 V < V _{SWxIN} < 4.5 V, 0 < I _{SWx} < 1.0 A 1.1 V ≤ V _{SWx} ≤ 1.5 V	-45	—	45	mV
V _{SWx}	Output voltage accuracy DVS disabled mode (OTP_SWx_DVS_SEL = 1) Normal power mode, 2.5 V < V _{SWxIN} < 4.5 V, 0 < I _{SWx} < 1.0 A 1.8 V ≤ V _{SWx} ≤ 3.3 V	-3.0	—	3.0	%
V _{SWx}	Output voltage accuracy DVS disabled mode (OTP_SWx_DVS_SEL = 1) Low-power mode, 2.5 V < V _{SWxIN} < 4.5 V, 0 < I _{SWx} < 0.1 A 1.1 V < V _{SWx} ≤ 1.5 V	-55	—	55	mV

Power management integrated circuit (PMIC) for low power application processors

Symbol	Parameter	Min	Typ	Max	Unit
V_{SWx}	Output voltage accuracy DVS disabled mode (OTP_SWx_DVS_SEL = 1) Low-power mode, $2.5\text{ V} < V_{SWxIN} < 4.5\text{ V}$, $0 < I_{SWx} < 0.1\text{ A}$ $1.8\text{ V} \leq V_{SWx} \leq 3.3\text{ V}$	-4.0	—	4.0	%
ΔV_{SWx}	Output ripple	—	5.0	—	mV
SWxEFF	Efficiency $V_{SWxIN} = 3.6\text{ V}$, $L_{SWx} = 1.0\text{ }\mu\text{H}$, $\text{DCR} = 50\text{ m}\Omega$ LP/ ULP mode, 1.2 V , 1.0 mA	—	88	—	%
SWxEFF	Efficiency $V_{SWxIN} = 3.6\text{ V}$, $L_{SWx} = 1.0\text{ }\mu\text{H}$, $\text{DCR} = 50\text{ m}\Omega$ Normal power mode, 1.2 V , 50 mA	—	90	—	%
SWxEFF	Efficiency $V_{SWxIN} = 3.6\text{ V}$, $L_{SWx} = 1.0\text{ }\mu\text{H}$, $\text{DCR} = 50\text{ m}\Omega$ Normal power mode, 1.2 V , 150 mA	—	92	—	%
SWxEFF	Efficiency $V_{SWxIN} = 3.6\text{ V}$, $L_{SWx} = 1.0\text{ }\mu\text{H}$, $\text{DCR} = 50\text{ m}\Omega$ Normal power mode, 1.2 V , 400 mA	—	89	—	%
SWxEFF	Efficiency $V_{SWxIN} = 3.6\text{ V}$, $L_{SWx} = 1.0\text{ }\mu\text{H}$, $\text{DCR} = 50\text{ m}\Omega$ Normal power mode, 1.2 V , 1000 mA	—	83	—	%
$I_{SWxLIMH}$	Current limiter peak (high-side MOSFET) current detection SWxLIM[1:0] = 00 SWxLIM[1:0] = 01 SWxLIM[1:0] = 10 SWxLIM[1:0] = 11	0.7 0.8 1.0 1.4	1.0 1.2 1.5 2.0	1.3 1.6 2.0 2.6	A
$I_{SWxLIML}$	Current limiter low-side MOSFET current detection (sinking current)	0.7	1.0	1.3	A
I_{SWxQ}	Quiescent current (at $25\text{ }^\circ\text{C}$) Low-power mode with DVS disabled (OTP_SWx_DVS_SEL = 1)	—	1.0	—	μA
I_{SWxQ}	Quiescent current (at $25\text{ }^\circ\text{C}$) Low-power mode with DVS enabled (OTP_SWx_DVS_SEL = 0)	—	6.0	—	μA
I_{SWxQ}	Quiescent current (at $25\text{ }^\circ\text{C}$) Normal power mode with DVS disabled (OTP_SWx_DVS_SEL = 1)	—	5.5	—	μA
I_{SWxQ}	Quiescent current (at $25\text{ }^\circ\text{C}$) Normal power mode with DVS enabled (OTP_SWx_DVS_SEL = 0)	—	10	—	μA
V_{SWxOSH}	Startup overshoot (Normal mode) $I_{SWx} = 0\text{ mA}$ DVS speed = $12.5\text{ mV}/4\text{ }\mu\text{s}$, $V_{SYS} = V_{SWxIN} = 3.6\text{ V}$, $V_{SWx} = 1.35\text{ V}$	—	—	25	mV
t_{ONSWx}	Turn on time 10 % to 90 % of end value DVS speed = $12.5\text{ mV}/4\text{ }\mu\text{s}$, $V_{SYS} = V_{SWxIN} = 3.6\text{ V}$, $V_{SWx} = 1.35\text{ V}$	—	—	500	μs
$V_{SWxLOTR}$	Transient load regulation (Normal power mode) Transient load = 50 mA to 250 mA , $di/dt = 200\text{ mA}/\mu\text{s}$ Overshoot Undershoot	— —	25 25	— —	mV

Symbol	Parameter	Min	Typ	Max	Unit
R _{ONSWxP}	SWx P-MOSFET R _{DS(on)} at V _{SWxIN} = 3.6 V	—	200	—	mΩ
R _{ONSWxN}	SWx N-MOSFET R _{DS(on)} at V _{SWxIN} = 3.6 V	—	150	—	mΩ
R _{SWxDIS}	Turn off discharge resistance	—	500	—	Ω

5.3.3 Electrical characteristics – SW3

All parameters are specified at T_A = -40 to 105 °C, V_{SYS} = V_{SW3IN} = 2.5 to 4.5 V, V_{SW3} = 1.8 V, I_{SW3} = 200 mA, typical external component values, f_{SW3} = 2.0 MHz, unless otherwise noted. Typical values are characterized at V_{SYS} = V_{SW3IN} = 3.6 V, V_{SW3} = 1.8 V, I_{SW3} = 200 mA, and 25 °C, unless otherwise noted.

Table 12. SW3 electrical characteristics

Symbol	Parameter	Min	Typ	Max	Unit
V _{SW3IN}	Operating input voltage	2.5	—	4.5	V
V _{SW3}	Output voltage accuracy (all voltage settings) Normal power mode, 2.5 V < V _{SW3IN} < 4.5 V, 0 < I _{SW3} < 1.0 A	-2.0	—	2.0	%
V _{SW3}	Output voltage accuracy (all voltage settings) Low-power mode, 2.5 V < V _{SW3IN} < 4.5 V, 0 < I _{SW3} < 0.1 A	-3.0	—	3.0	%
ΔV _{SW3}	Output ripple	—	5.0	—	mV
SW3EFF	Efficiency V _{SW3IN} = 3.6 V, L _{SW3} = 1.0 μH, DCR = 50 mΩ LP/ ULP Mode, 1.8 V, 1.0 mA	—	88	—	%
SW3EFF	Efficiency V _{SW3IN} = 3.6 V, L _{SWx} = 1.0 μH, DCR = 50 mΩ Normal power mode, 1.8 V, 50 mA	—	90	—	%
SW3EFF	Efficiency V _{SW3IN} = 3.6 V, L _{SWx} = 1.0 mH, DCR = 50 mΩ Normal power mode, 1.8 V, 100 mA	—	91	—	%
SW3EFF	Efficiency V _{SW3IN} = 3.6 V, L _{SWx} = 1.0 μH, DCR = 50 mΩ Normal power mode, 1.8 V, 400 mA	—	92	—	%
SW3EFF	Efficiency V _{SW3IN} = 3.6 V, L _{SWx} = 1.0 μH, DCR = 50 mΩ Normal power mode, 1.8 V, 1000 mA	—	83	—	%
I _{SW3LIMH}	Current limiter peak (high-side MOSFET) current detection SW3ILIM[1:0] = 00 SW3ILIM[1:0] = 01 SW3ILIM[1:0] = 10 SW3ILIM[1:0] = 11	0.7 0.8 1.0 1.4	1.0 1.2 1.5 2.0	1.3 1.6 2.0 2.6	A
I _{SW3LIML}	Current limiter low-side MOSFET current detection (sinking current)	0.7	1.0	1.3	A
I _{SW3Q}	Quiescent current (at 25 °C) Low-power mode	—	1.0	—	μA

Symbol	Parameter	Min	Typ	Max	Unit
V _{SW3OSH}	Start-up overshoot (Normal mode) I _{SW3} = 0 mA V _{SYS} = V _{SW3IN} = 3.6 V, V _{SW3} = 1.8 V	—	—	50	mV
t _{ONSW3}	Turn on time 10 % to 90 % of end value V _{SYS} = V _{SW3IN} = 3.6 V, V _{SW3} = 1.8 V	—	—	500	μs
V _{SW3LOTR}	Transient load regulation (Normal power mode) Transient load = 50 mA to 250 mA, di/dt = 200 mA/μs Overshoot Undershoot	— —	50 50	— —	mV
R _{ONSW3N}	SW3 N-MOSFET R _{DS(on)} at V _{SW3IN} = 3.6 V	—	150	—	mΩ
R _{ONSW3P}	SW3 P-MOSFET R _{DS(on)} at V _{SW3IN} = 3.6 V	—	200	—	mΩ
R _{SW3DIS}	Turn off discharge resistance	—	300	—	Ω

5.3.4 Electrical characteristics – LDO1

All parameters are specified at T_A = -40 to 105 °C, V_{SYS} = 2.5 to 4.5 V, V_{LDO1IN} = 3.6 V, V_{LDO1}[4:0] = 11111, I_{LDO1} = 10 mA, typical external component values, unless otherwise noted. Typical values are characterized at V_{SYS} = 3.6 V, V_{LDO1IN} = 3.6 V, V_{LDO1}[4:0] = 11111, I_{LDO1} = 10 mA, and 25 °C, unless otherwise noted.

Table 13. LDO1 electrical characteristics

Symbol	Parameter	Min	Typ	Max	Unit
V _{LDO1IN}	Operating input voltage V _{LDO1} + 250 mV ≤ V _{SYS} ≤ 4.5 V	1.0	—	4.5	V
V _{LDO1NOM}	Nominal output voltage	—	See Table 33	—	V
I _{LDO1MAX}	Rated output load current, Normal mode	300	—	—	mA
I _{LDO1MAXLPM}	Rated output load current, Low-power mode	10	—	—	mA
V _{LDO1TOL}	Output voltage tolerance, Normal mode V _{LDO1INMIN} < V _{LDO1IN} < 4.5 V, 0 mA < I _{LDO1} ≤ 300 mA 0.8 V ≤ V _{LDO1} < 1.8 V 1.8 V ≤ V _{LDO1} ≤ 3.3 V V _{LDO1INMIN} < V _{LDO1IN} < 4.5 V, 0 mA < I _{LDO1} < 10 mA (Low-power mode)	-2.5 -2.5 -4.0	— — —	2.5 2.5 4.0	%
I _{LDO1LIM}	Current limit I _{LDO1} when V _{LDO1} is forced to V _{LDO1NOM} /2	320	—	1000	mA
I _{LDO1OCP}	LDO1FAULTI threshold (also used to disable LDO1 when REGSCPEN = 1)	320	—	1000	mA
I _{LDO1Q}	Quiescent current (at 25 °C) No load, change in I _{VSYS} and I _{VLDO1IN} When LDO1 enabled in Normal mode When LDO1 enabled in Low-power mode	— —	17 2.5	— —	μA
R _{DS(on)_QFN_LDO1}	Dropout on resistance	—	—	350	mΩ

Symbol	Parameter	Min	Typ	Max	Unit
PSRR _{LDO1}	PSRR I _{LDO1} = 150 mA, 20 Hz to 20 kHz V _{LDO1} = 3.30 V, V _{LDO1IN} = 3.8 V, V _{SYS} = 4.2 V	—	56	—	dB
TR _{V_{LDO1}}	Turn on time 10 % to 90 % of end value V _{LDO1INMIN} < V _{LDO1IN} ≤ 4.5 V, I _{LDO1} = 0.0 mA	—	200	500	μs
R _{LDO1DIS}	Turn off discharge resistance	—	250	—	Ω
LDO1OUT _{OSHT}	Start-up overshoot (% of final value) V _{LDO1INMIN} < V _{LDO1IN} ≤ 4.5 V, I _{LDO1} = 0.0 mA	—	1.0	2.0	%
V _{LDO1LOTR}	Transient load response V _{LDO1INMIN} < V _{LDO1IN} ≤ 4.5 V, I _{LDO1} = 10 mA to 200 mA in 10 μs Overshoot Undershoot	— —	50 50	— —	mV

5.3.5 Electrical characteristics – LDO2

All parameters are specified at T_A = -40 to 105 °C, V_{SYS} = 3.6 V, V_{LDOIN2} = 3.6 V, VLDO2[3:0] = 1111, I_{LDO2} = 10 mA, typical external component values, unless otherwise noted. Typical values are characterized at V_{SYS} = 3.6 V, V_{LDOIN2} = 3.6 V, VLDO2[3:0] = 1111, I_{LDO2} = 10 mA, and 25 °C, unless otherwise noted.

Table 14. LDO2 electrical characteristics

Symbol	Parameter	Min	Typ	Max	Unit
V _{LDO2IN}	Operating input voltage 1.8 V ≤ V _{LDO2NOM} ≤ 2.5 V 2.6 V ≤ V _{LDO2NOM} ≤ 3.3 V	2.8 V _{LDO2NOM} + 0.250	— —	4.5 4.5	V
V _{LDO2NOM}	Nominal output voltage	—	See Table 35	—	V
I _{LDO2MAX}	Rated output load current, Normal mode	400	—	—	mA
I _{LDO2MAXLPM}	Rated output load current, Low-power mode	10	—	—	mA
V _{LDO2TOL}	Output voltage tolerance V _{LDO2INMIN} < V _{LDO2IN} < 4.5 V 10.0 mA ≤ I _{LDO2} < 400 mA 0.0 mA < I _{LDO2} < 10 mA (Low-power mode)	-2.0 -4.0	— —	2.0 4.0	%
I _{LDO2LIM}	Current limit I _{LDO2} when V _{LDO2} is forced to V _{LDO2NOM} /2	450	750	1050	mA
I _{LDO2OCP}	LDO2FAULTI threshold (also used to disable LDO2 when REGSCPEN = 1)	450	—	1050	mA
I _{LDO2Q}	Quiescent Current (25 °C) No load, change in I _{V_{SYS}} and I _{V_{LDO2IN}} When V _{LDO2} enabled in Normal mode When V _{LDO2} enabled in Low-power mode	— —	15 1.5	— —	μA
R _{DSON_QFN_LDO2}	Dropout on resistance	—	—	300	mΩ
PSRR _{V_{LDO2}}	PSRR I _{LDO2} = 200 mA, 20 Hz to 20 kHz V _{LDO2} = 3.30 V, V _{LDO2IN} = 3.9 V, V _{SYS} = 4.2 V	—	60	—	dB

Symbol	Parameter	Min	Typ	Max	Unit
t _{ONLDO2}	Turn on time 10 % to 90 % of end value V _{LDO2INMIN} < V _{LDO2IN} ≤ 4.5 V, I _{LDO2} = 0.0 mA	—	200	500	μs
R _{LDO2DIS}	Turn off discharge resistance	—	250	—	Ω
LDO2OUT _{OSHT}	Start-up overshoot (% of final value) V _{LDO2INMIN} < V _{LDO2IN} ≤ 4.5 V, I _{LDO2} = 0.0 mA	—	1.0	2.0	%
V _{LDO2LOTR}	Transient load response V _{LDO2INMIN} < V _{LDO2IN} ≤ 4.5 V, I _{LDO2} = 10 mA to 100 mA in 10 μs Overshoot Undershoot	— —	50 50	— —	mV

5.3.6 Electrical characteristics – LDO3

All parameters are specified at T_A = -40 to 105 °C, V_{SYS} = 2.5 to 4.5 V, V_{LDOIN3} = 3.6 V, V_{LDO3[4:0]} = 11111, I_{LDO3} = 10 mA, typical external component values, unless otherwise noted. Typical values are characterized at V_{SYS} = 3.6 V, V_{LDOIN3} = 3.6 V, V_{LDO3[4:0]} = 11111, I_{LDO3} = 10 mA, and 25 °C, unless otherwise noted.

Table 15. LDO3 electrical characteristics

Symbol	Parameter	Min	Typ	Max	Unit
V _{LDO3IN}	Operating input voltage V _{LDO3} + 250 mV ≤ V _{SYS} ≤ 4.5 V	1.0	—	4.5	V
V _{LDO3NOM}	Nominal output voltage	—	See Table 33	—	V
I _{LDO3MAX}	Rated output load current, Normal mode	300	—	—	mA
I _{LDO3MAXLPM}	Rated output load current, Low-power mode	10	—	—	mA
V _{LDO3TOL}	Output voltage tolerance, Normal mode V _{LDO3INMIN} < V _{LDO3IN} < 4.5 V, 0 mA < I _{LDO3} < 300 mA 0.8 V ≤ V _{LDO3} < 1.8 V 1.8 V ≤ V _{LDO3} ≤ 3.3 V V _{LDO3INMIN} < V _{LDO3IN} < 4.5 V, 0 mA < I _{LDO3} < 10 mA (Low-power mode)	— — —	— — —	2.5 2.5 4.0	%
I _{LDO3LIM}	Current limit I _{LDO3} when V _{LDO3} is forced to V _{LDO3NOM} /2	320	—	1000	mA
I _{LDO3OCP}	LDO3FAULTI threshold (also used to disable LDO3 when REGSCPEN = 1)	320	—	1000	mA
I _{LDO3Q}	Quiescent current (at 25 °C) No load, change in I _{VSYS} and I _{VLDOIN3} When LDO3 enabled in Normal mode When LDO3 enabled in Low-power mode	— —	17 2.5	— —	μA
R _{DSON_QFN_LDO3}	Dropout on resistance	—	—	350	mΩ
PSRR _{LDO3}	PSRR I _{LDO3} = 150 mA, 20 Hz to 20 kHz V _{LDO3} = 3.30 V, V _{LDO3IN} = 3.8 V, V _{SYS} = 4.2 V	—	56	—	dB

Symbol	Parameter	Min	Typ	Max	Unit
TR _{VLD03}	Turn on time 10 % to 90 % of end value V _{LDO3INMIN} < V _{LDO3IN} < 4.5 V, I _{LDO3} = 0.0 mA	—	200	500	μs
R _{LDO3DIS}	Turn off discharge resistance	—	250	—	Ω
LDO3OUT _{OSHT}	Start-up overshoot (% of final value) V _{LDO3INMIN} < V _{LDO3IN} ≤ 4.5 V, I _{LDO3} = 0.0 mA	—	1.0	2.0	%
V _{LDO3LOTR}	Transient load response V _{LDO3INMIN} < V _{LDO3IN} ≤ 4.5 V, I _{LDO3} = 10 mA to 100 mA in 10 μs Overshoot Undershoot	— —	50 50	— —	mV

5.3.7 Electrical characteristics – VREFDDR

T_A = -40 to 105 °C, V_{SY}S = 2.5 to 4.5 V, I_{REFDDR} = 0.0 mA, V_{INREFDDR} = 1.35 V and typical external component values, unless otherwise noted. Typical values are characterized at V_{SY}S = 3.6 V, I_{REFDDR} = 0.0 mA, V_{INREFDDR} = 1.35 V, and 25 °C, unless otherwise noted.

Table 16. VREFDDR electrical characteristics

Symbol	Parameter	Min	Typ	Max	Unit
V _{INREFDDR}	Operating input voltage range	0.9	—	1.8	V
V _{REFDDR}	Output voltage, 0.9 V < V _{INREFDDR} < 1.8 V, 0 mA < I _{REFDDR} < 10 mA	—	V _{INREFDDR} /2	—	V
V _{REFDDRTOL}	Output voltage tolerance, as a percentage of V _{INREFDDR} , 1.2 V < V _{INREFDDR} < 1.65 V, 0 mA < I _{REFDDR} < 10 mA	49.25	50	50.75	%
I _{REFDRQ}	Quiescent current (at 25 °C)	—	1.1	—	μA
I _{REFDRLM}	Current limit, I _{REFDDR} when V _{REFDDR} is forced to V _{INREFDDR} /4	10.5	24	38	mA
t _{ONREFDDR}	Turn on time, 10 % to 90 % of end value, V _{INREFDDR} = 1.2 V to 1.65 V, I _{REFDDR} = 0.0 mA	—	—	100	μs

5.3.8 Electrical characteristics – VSNVS

All parameters are specified at T_A = -40 to 105 °C, V_{SY}S = 3.6 V, V_{SNVS} = 3.0 V, I_{SNVS} = 5.0 μA, typical external component values, unless otherwise noted. Typical values are characterized at V_{SY}S = 3.6 V, V_{SNVS} = 3.0 V, I_{SNVS} = 5.0 μA, and 25 °C, unless otherwise noted.

Table 17. VSNVS electrical characteristics

Symbol	Parameter	Min	Typ	Max	Unit
V _{SNVSIN}	Operating input voltage Valid coin cell range Valid V _{SY} S	1.8 2.45	— —	3.3 4.5	V
I _{SNVS}	Operating load current V _{SNVSINMIN} < V _{SNVSIN} < V _{SNVSINMAX}	2000	—	—	μA
V _{TL1}	V _{SY} S threshold (V _{SY} S powered to coin cell powered)	—	UVDET failing	—	V
V _{TH1}	V _{SY} S threshold (coin cell powered to V _{SY} S powered)	—	UVDET rising	—	V

Symbol	Parameter	Min	Typ	Max	Unit
V _{SNVS}	Output voltage (when running from V _{SYS}) 0 μA < I _{SNVS} < 2000 μA	-7.0 %	3.0	7.0 %	V
	Output voltage (when running from LICELL) 0 μA < I _{SNVS} < 2000 μA 2.84 V < V _{COIN} < 3.3 V	V _{COIN} - 0.20	—	—	
V _{SNVSDROP}	Dropout voltage V _{SYS} = 2.9 V I _{SNVS} = 2000 μA	—	—	220	mV
I _{SNVSLIM}	Current limit V _{SYS} > V _{TH1}	5200	—	24000	μA
V _{SNVSTON}	Turn on time (load capacitor, 0.47 μF) 10 % to 90 % of final value V _{SNVS} V _{COIN} = 0.0 V, I _{SNVS} = 0 μA	—	—	3.0	ms
V _{SNVSOSH}	Start-up overshoot I _{SNVS} = 5.0 μA dV _{SYS} /dt = 50 mV/μs	—	40	70	mV
R _{DSONSNVS}	Internal switch R _{DS(on)} V _{COIN} = 2.6 V	—	—	100	Ω

5.3.9 Electrical characteristics – IC level bias currents

All parameters are specified at 25 °C, V_{SYS} = 3.6 V, V_{IN} = 0 V, typical external component values, unless otherwise noted. Typical values are characterized at V_{SYS} = 3.6 V, V_{SNVS} = 3.0 V, and 25 °C, unless otherwise noted.

Table 18. IC level electrical characteristics

Mode	PF1510 conditions	System conditions	Typ	Max	Unit
Coin cell	V _{SNVS} from LICELL All other blocks off V _{SYS} = 0.0 V	No load on V _{SNVS}	1.5	4.0	μA
CORE_OFF	V _{SNVS} from V _{SYS} Wake-up from ONKEY active All other blocks off V _{SYS} > UVDET	No load on V _{SNVS} , PMIC able to wake-up	1.5	4.0	μA
Sleep	V _{SNVS} from V _{SYS} Wake-up from PWRON active Trimmed reference active DDR I/O rail in Low-power mode VREFDDR disabled	No load on V _{SNVS} . DDR memories in self refresh.	12.5	25	μA

Mode	PF1510 conditions	System conditions	Typ	Max	Unit
Standby/Suspend	VSNVS from either VSYS or LICELL SW1 in ultra Low-power mode SW2 in ultra Low-power mode SW3 in ultra Low-power mode Trimmed reference active VLDO1 is disabled VLDO2 enabled in Low-power mode VLDO3 enabled in Low-power mode VREFDDR enabled	No load on VSNVS. Processor enabled in Low-power mode.	23	46	µA
REGS_DISABLE	VSNVS from VSYS Wake-up from ONKEY active Other blocks are off VSYS > UVDET	No load on VSNVS, PMIC able to wake-up	14	20	µA

6 Detailed description

The PF1510 PMIC features three high efficiency low quiescent current buck regulators, three LDO regulators, a DDR voltage reference to supply voltages for the application processor and peripheral devices.

The buck regulators provide the supply to processor cores and to other low voltage circuits such as I/O and memory. Dynamic voltage scaling is provided to allow controlled supply rail adjustments for the processor cores for power optimization.

The three LDO regulators are general purpose to power various processor rails, system connectivity devices and/or peripherals. Depending on the system power configuration, the general purpose LDO regulators can be directly supplied from the main system supply VSYS or from the switching regulators to power peripherals, such as audio, camera, Bluetooth, Wireless LAN.

A specific VREFDDR voltage reference is included to provide accurate reference voltage for DDR memories operation.

The VSNVS block behaves as an LDO, or as a bypass switch to supply the SNVS (Secure Non-Volatile Storage)/RTC (Real Time Clock) circuitry on the processor. VSNVS is powered from VSYS or from a coin cell.

The PF1510 uses an integrated linear front-end LDO that provides 4.5 V at VSYS from the 5.0 V VIN.

Table 19. Voltage regulators

Supply	Output voltage (V)	Programming step size (mV)	Load current (mA)
SW1 / SW2	0.60 to 1.3875 / 1.1 to 3.3	12.5/variable	1000
SW3	1.80 to 3.30	100	1000
LDO1	0.75 to 1.50 1.80 to 3.30	50 100	300
LDO2	1.80 to 3.30	100	400
LDO3	0.75 to 1.50 1.80 to 3.30	50 100	300

Supply	Output voltage (V)	Programming step size (mV)	Load current (mA)
USBPHY	3.3 or 4.9	—	60
VSNVS	3.0	N/A	2
VREFDDR	0.5*VINREFDDR	N/A	10

6.1 Buck regulators

The PF1510 features three high efficiency buck regulators with internal compensation. Each buck regulator is capable of meeting optimum power efficiency operation using reduced power variable-frequency pulse skip switching scheme at light loads as well as operating in forced PWM quasi-fixed frequency switching mode at higher loads. The switching regulator controller combines the advantages of hysteretic and voltage mode control which provides outstanding load regulation and transient response, low output ripple voltage and seamless transition between pulse-skip mode and Active Quasi-fixed frequency switching mode. The control circuitry includes an AC loop which senses the output voltage (at SWx_{FB} pin) and directly feeds it to a fast comparator stage. This comparator sets the switching frequency, which is almost constant for steady state operating conditions. It also provides immediate response to dynamic load changes.

In order to achieve accurate DC load regulation, a voltage feedback loop is used. The internally compensated regulation network achieves fast and stable operation with small external components and low ESR capacitors. The transition into and out of low power pulse-skip switching mode takes place automatically according to the load current to maintain optimum power efficiency. Additionally, further power savings through cutting the buck circuitry quiescent current can be achieved by activating a Low-power mode upon entering either STANDBY or SLEEP PMIC power mode or as commanded via I²C control bits. In SW1 and SW2. An OTP option enables or disables DVS in the regulators. When DVS is disabled and the low-power bit is set, the regulator enters an Ultra Low Power (ULP) mode cuts the operating quiescent current even in order to reach extremely low standby power levels needed for ultra low power processors such as that from Kinetis K and L series.

As indicated above, the buck controller supports PWM (Pulse Width Modulation) mode for medium and high load conditions and low-power variable-frequency pulse skip mode at light loads. During high current mode, it operates in continuous conduction and the switching frequency is up to 2.0 MHz with a controlled on-time variation depending on the input voltage and output voltage. If the load current decreases, the converter seamlessly enters the pulse-skip mode to cut the operating quiescent current and maintain high efficiency down to very light loads. In pulse-skip mode the switching frequency varies linearly with the load current. Since the controller supports both power modes within one single building block, the transition from normal power mode to lower power pulse-skip mode and vice versa is seamless without dramatic effects on the output voltage.

In the adopted pulse-skip scheme, the device generates a single switching pulse to ramp up the inductor current and recharge the output capacitor, followed by a non-switching (pause) period where most of the internal circuits are shutdown to achieve a lowest quiescent current. During this time, the load current is supported by the output capacitor. The duration of the pause period depends on the load current and the inductor peak current.

6.2 SW1 and SW2 detailed description

SW1 and SW2 are identical buck regulators designed to carry a nominal load current of 1.0 A. Detailed characteristics and features of SW1 and SW2 are described in this section. Being identical, reference is made only to SWx though the same specifications apply to SW1 and SW2.

6.2.1 SWx dynamic voltage scaling description

SWx integrates an optional DVS circuit that is enabled via OTP. To reduce overall power consumption, when DVS is enabled SWx output voltage can be varied depending on the mode or activity level of the processor.

- **Normal operation:**

The output voltage is selected by I²C bits SWx_VOLT[5:0]. A voltage transition initiated by I²C is governed by the SWx_DVSSPEED I²C bit as shown in [Table 20](#).

- **Standby mode:**

The output voltage can be selected by I²C bits SWx_STBY_VOLT[5:0]. Voltage transitions initiated by a Standby event are governed by the SWx_DVSSPEED I²C bit as shown in [Table 20](#). This applies only when DVS is enabled.

- **Sleep mode:**

The output voltage can be higher or lower than in normal operation, but is typically selected to be the lowest state retention voltage of a given processor; it is selected by I²C bits SWx_SLP_VOLT[5:0]. Voltage transitions initiated by a turn off event are governed by the SWx_DVSSPEED I²C bit for SWx as shown in [Table 20](#). This applies only when DVS is enabled.

As shown in [Figure 5](#), during a falling DVS transition, dv/dt of the output voltage depends on the load current. Setting the SWx_FPWM_IN_DVS bit forces the regulator in the FPWM mode during the falling transition allowing it to accurately track the DVS reference removing the load dependency. The SWx_FPWM_IN_DVS bit is active only when OTP_SWx_DVS_SEL = 0.

Table 20. SWx DVS setting selection

SWx_DVS speed	Function
0	12.5 mV step each 2.0 μs
1	12.5 mV step each 4.0 μs

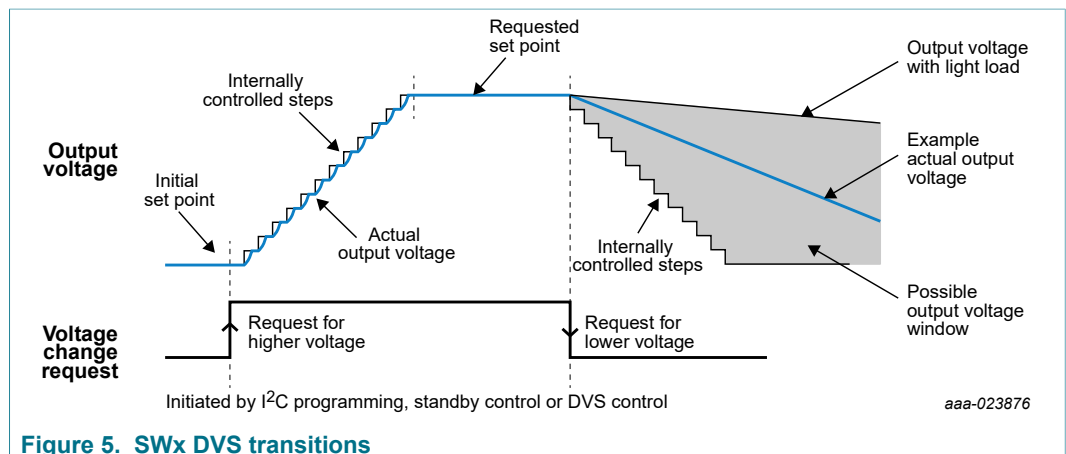

Figure 5. SWx DVS transitions

6.2.2 SWx DVS and non-DVS operation

SWx has two distinct modes of operation selectable via OTP:

- DVS enabled: a DVS reference is activated and output accuracy of the regulator is tight at the cost of slightly higher quiescent current. See [Section 5.3 "Electrical characteristics"](#) for details. In [Figure 6](#), **DVS FB** and **DVS REF** are enabled via OTP for this mode of operation.
- DVS disabled: the regulator operates as a traditional buck converter with a fixed reference and soft-start. The quiescent current in this mode is lower at the cost of output accuracy and transient response. See [Section 5.3 "Electrical characteristics"](#) for details. In [Figure 6](#), **VREF FB** and **VREF** are enabled via OTP for this mode of operation.

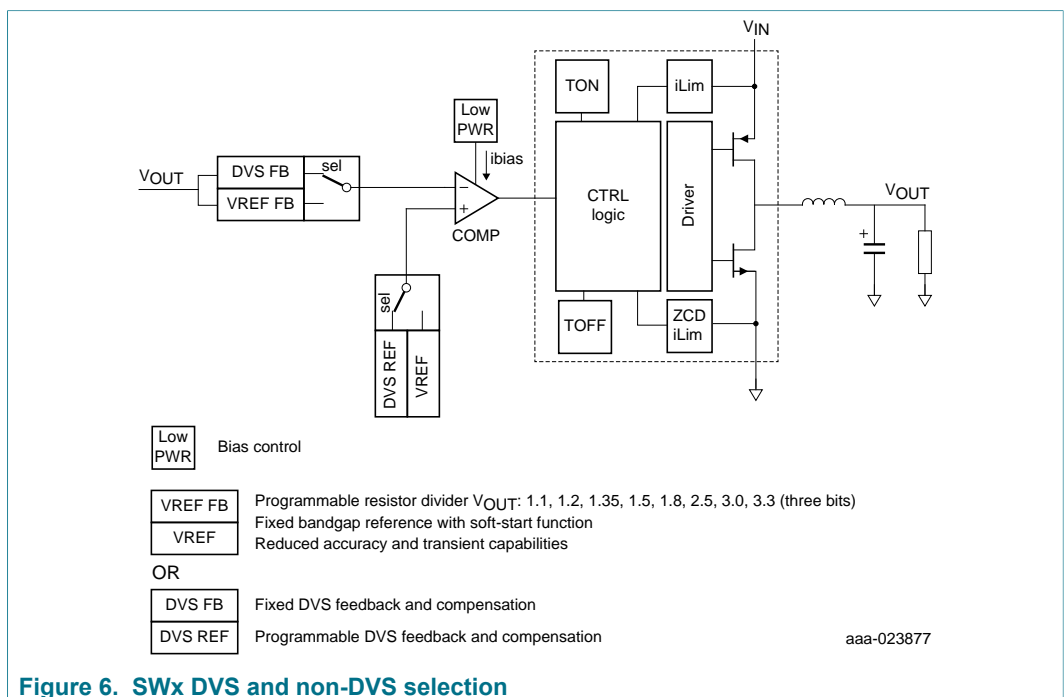

Figure 6. SWx DVS and non-DVS selection

6.2.3 Regulator control

To improve system efficiency, the buck regulators can operate in different switching/bias modes. The changing between DCM (Discontinuous Conduction Mode)/CCM (Continuous Conduction Mode) takes place automatically based on detecting the load current level. It can be enforced by one of the following means: I²C programming, exiting/entering the Standby mode, exiting/entering Sleep/Low-power mode.

Available modes for buck regulators are presented in [Table 21](#). These switching modes are available with OTP_SWx_DVS_SEL = 0 and OTP_SWx_DVS_SEL = 1. [Table 22](#) shows the bit settings for operating the buck converter in these modes based on the PMIC operating state.

Table 21. Buck regulator operating modes

Mode	Description
OFF	The regulator is switched off and the output voltage is discharged using an internal resistor.

Power management integrated circuit (PMIC) for low power application processors

Mode	Description
Adaptive	This is the default mode of operation of the buck regulator. In this mode, the regulator operates in a quasi-fixed frequency switching mode at moderate and high loads, with pulse skip (variable switching frequency) scheme at light load for optimized efficiency.
F-PWM	In this mode, the regulator is always in PWM mode operation regardless of load conditions.
Low-power	To further extend power savings when the load current is minimal, this mode cuts the quiescent current of the buck converter by reducing the bias to the comparator. The regulator is operated in low power modes (Standby and/or Sleep) with the proper I ² C setting. See Table 22 .

The following table shows actions to control different bits for SW1 and SW2.

Table 22. Buck mode control

PMIC state	SWx_EN	SWx_STBY	SWx_OMODE	SWx_LPWR	SWx_FPWM	SWx operating mode
Run/Standby /Sleep	0	X	X	X	X	SW disabled
Run	1	X	X	0	0	SW enabled. Operates in DCM at light loads
Run	1	X	X	0	1	SW enabled. Forced PWM mode
Run	1	X	X	1	0	SW Enabled. Does not operate in Low-power mode.
Run	1	X	X	1	1	SW enabled. Forced PWM mode
Standby	1	0	X	X	X	SW disabled
Standby	1	1	X	0	0	SW enabled. Operates in DCM at light loads.
Standby	1	1	X	0	1	SW enabled. Forced PWM mode.
Standby	1	1	X	1	0	SW enabled. Operates in Low-power mode.
Standby	1	1	X	1	1	SW enabled. Forced PWM mode
Sleep	1	X	0	X	X	SW disabled
Sleep	1	X	1	0	0	SW enabled. Operates in DCM at light loads.
Sleep	1	X	1	0	1	SW enabled. Forced PWM mode.
Sleep	1	X	1	1	0	SW enabled. Operates in Low-power mode.
Sleep	1	X	1	1	1	SW enabled. Forced PWM mode

6.2.4 Current limit protection

SWx features high and low-side FET current limit. When current through the FETs goes above their respective thresholds, the FET is turned off to prevent further increase in current.

The protection is enabled in a cycle-by-cycle mode. Hitting either current limit sets the corresponding interrupt sense bits. If the faults persist for longer than the 8.0 ms debounce time, the interrupt status bit is set.

6.2.5 Output voltage setting in SWx

Output voltage of SWx is programmable via OTP. During startup (REGS_DISABLE mode to RUN mode), contents of the OTP_SWx_VOLT[5:0] are mapped into the SWx_VOLT[5:0], SWx_STBY_VOLT[5:0] and SWx_SLP_VOLT[5:0] register which set the regulator output voltage during Run, Standby and Sleep modes respectively.

Power management integrated circuit (PMIC) for low power application processors

In the DVS enabled mode (OTP_SWx_DVS_SEL = 0), values of SWx_VOLT[5:0], SWx_STBY[VOLT[5:0] and SWx_SLP_VOLT[5:0] can be changed via I²C after the PMIC starts up (RESETBMCU is released).

In the DVS disabled mode (OTP_SWx_DVS_SEL = 1), value of SWx_VOLT[5:0], SWx_STBY[VOLT[5:0] and SWx_SLP_VOLT[5:0] are read-only and must not be written to.

Table 23. SW1 and SW2 output voltage setting

Set point	SWx_VOLT[5:0] SWx_STBY_VOLT[5:0] SWx_SLP_VOLT[5:0]	Output voltage with DVS enabled OTP_SWx_DVS_SEL = 0	Output voltage with DVS disabled OTP_SWx_DVS_SEL = 1
0	000000	0.6000	1.10
1	000001	0.6125	1.20
2	000010	0.6250	1.35
3	000011	0.6375	1.50
4	000100	0.6500	1.80
5	000101	0.6625	2.50
6	000110	0.6750	3.00
7	000111	0.6875	3.30
8	001000	0.7000	3.30
9	001001	0.7125	3.30
10	001010	0.7250	3.30
11	001011	0.7375	3.30
12	001100	0.7500	3.30
13	001101	0.7625	3.30
14	001110	0.7750	3.30
15	001111	0.7875	3.30
16	010000	0.8000	3.3
17	010001	0.8125	3.30
18	010010	0.8250	3.30
19	010011	0.8375	3.30
20	010100	0.8500	3.30
21	010101	0.8625	3.30
22	010110	0.8750	3.30
23	010111	0.8875	3.30
24	011000	0.9000	3.30
25	011001	0.9125	3.30
26	011010	0.9250	3.30
27	011011	0.9375	3.30
28	011100	0.9500	3.30

Power management integrated circuit (PMIC) for low power application processors

Set point	SWx_VOLT[5:0] SWx_STBY_VOLT[5:0] SWx_SLP_VOLT[5:0]	Output voltage with DVS enabled OTP_SWx_DVS_SEL = 0	Output voltage with DVS disabled OTP_SWx_DVS_SEL = 1
29	011101	0.9625	3.30
30	011110	0.9750	3.30
31	011111	0.9875	3.30
32	100000	1.0000	3.30
33	100001	1.0125	3.30
34	100010	1.0250	3.30
35	100011	1.0375	3.30
36	100100	1.0500	3.30
37	100101	1.0625	3.30
38	100110	1.0750	3.30
39	100111	1.0875	3.30
40	101000	1.1000	3.30
41	101001	1.1125	3.30
42	101010	1.125	3.30
43	101011	1.1375	3.30
44	101100	1.1500	3.30
45	101101	1.1625	3.30
46	101110	1.1750	3.30
47	101111	1.1875	3.30
48	110000	1.2000	3.30
49	110001	1.2125	3.30
50	110010	1.2250	3.30
51	110011	1.2375	3.30
52	110100	1.2500	3.30
53	110101	1.2625	3.30
54	110110	1.2750	3.30
55	110111	1.2875	3.30
56	111000	1.3000	3.30
57	111001	1.3125	3.3
58	111010	1.3250	3.30
59	111011	1.3375	3.30
60	111100	1.3500	3.30
61	111101	1.3625	3.30
62	111110	1.3750	3.30
63	111111	1.3875	3.30

6.2.6 SWx external components

Table 24 shows the combination of inductor and capacitor values that work with the SWx regulator.

The design is optimized for a 1.0 μH inductor.

Table 24. Acceptable inductance and capacitance values

Inductance / capacitance	2 x 10 μF
1.0 μH	

Table 25 and Table 26 show example inductor and capacitor part numbers respectively.

Table 25. Example inductor part numbers

Part number	Size (mm)	1.0 μH
DFE201610E	2.0 x 1.6	57 mΩ, 3.6 A
DFE201610P	2.0 x 1.6	70 mΩ, 3.1 A
DFE201210U	2.0 x 1.2	95 mΩ, 3.1 A
DFE160810S	1.6 x 0.8	120 mΩ, 2.0 A
DFE201208S	2.0 x 1.2	86 mΩ, 2.4 A
DFE160808S	1.6 x 0.8	144 mΩ, 1.9 A

Table 26. Example capacitor part numbers

Murata part number	Description
GRM188R60J106ME47D	6.3 V, 10 μF, 0402, X5R
GRM188D70J106MA73	6.3 V, 10 μF, 0402, X7R
GRM188R61A106KE69	10 μF 10 V 10 % X5R 0603 .95 mm
GRM219R61A106KE44	10 μF 10 V 10 % X5R 0805 .95 mm

6.3 SW3 detailed description

SW3 is a buck regulator designed to carry a nominal load current of 1.0 A. The output voltage is programmable from 1.8 V to 3.3 V in 100 mV steps. Dynamic voltage scaling is not supported in this regulator.

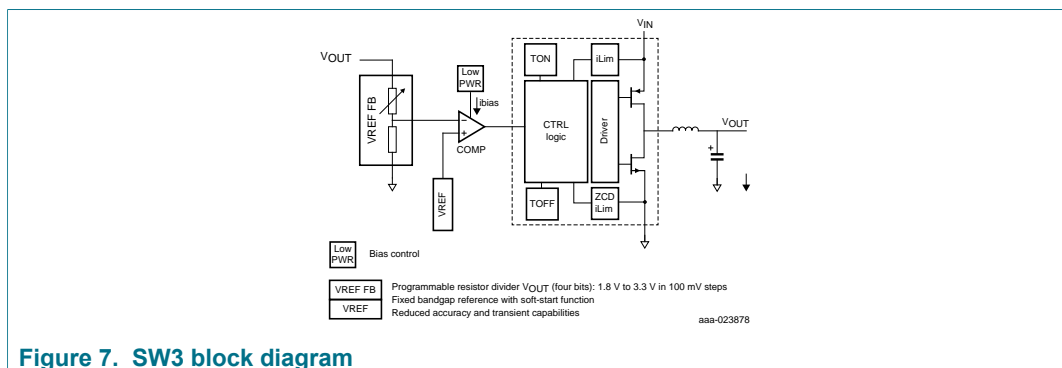

Figure 7. SW3 block diagram

6.3.1 Regulator control

To improve system efficiency the buck regulator can operate in different switching/ bias modes. The changing between DCM/CCM takes place automatically based on detecting the load current level. It can be enforced by one of the following means: I²C programming, exiting/entering the Standby mode, exiting/entering Sleep/ Low-power mode.

Available modes for buck regulators are presented in [Table 27](#) .

[Table 28](#) shows the bit settings for operating the buck converter in these modes based on the PMIC operating state.

Table 27. SW3 buck regulator operating modes

Mode	Description
OFF	The regulator is switched off and the output voltage is discharged using an internal resistor.
Adaptive	This is the default mode of operation of the buck regulator. In this mode, the regulator operates in a quasi-fixed frequency switching mode at moderate and high loads, with pulse skip (variable switching frequency) scheme at light load for optimized efficiency.
F-PWM	In this mode, the regulator is always in PWM mode operation regardless of load conditions.
Low-power	To further extend power savings when the load current is minimal, this mode cuts the quiescent current of the buck converter by reducing the bias to the comparator. The regulator is operated in low power modes (Standby and/or Sleep) with the proper I ² C setting. See Table 28 .

Table 28. SW3 buck mode control

PMIC state	SW3_EN	SW3_STBY	SW3_OMODE	SW3_LPWR	SW3_FPWM	SW3 operating mode
Run/ Standby/ Sleep	0	X	X	X	X	SW disabled
Run	1	X	X	0	0	SW enabled Operates in DCM at light loads
Run	1	X	X	0	1	SW enabled Forced PWM mode
Run	1	X	X	1	0	SW enabled Does not operate in Low-power mode
Run	1	X	X	1	1	SW enabled Forced PWM mode
Standby	1	0	X	X	X	SW disabled
Standby	1	1	X	0	0	SW enabled Operates in DCM at light loads
Standby	1	1	X	0	1	SW enabled Forced PWM mode

PMIC state	SW3_EN	SW3_STBY	SW3_OMODE	SW3_LPWR	SW3_FPWM	SW3 operating mode
Standby	1	1	X	1	0	SW enabled operates in Low-power mode
Standby	1	1	X	1	1	SW enabled Forced PWM mode
Sleep	1	X	0	X	X	SW disabled
Sleep	1	X	1	0	0	SW enabled Operates in DCM at light loads
Sleep	1	X	1	0	1	SW enabled Forced PWM mode
Sleep	1	X	1	1	0	SW enabled Operates in Low-power mode
Sleep	1	X	1	1	1	SW enabled Forced PWM mode

6.3.2 Current limit protection

SW3 features high and low-side FET current limit. When current through the FETs goes above their respective thresholds, the FET is turned off to prevent further increase in current.

The protection is enabled in a cycle-by-cycle mode. Hitting either current limit sets the corresponding interrupt sense bits. If the faults persist for longer than the 8.0 ms debounce time, the interrupt status bit is set.

6.3.3 Output voltage setting in SW3

Output voltage of SW3 is programmable via OTP. During start up (REGS_DISABLE mode to RUN mode), contents of the OTP_SW3_VOLT[5:0] are mapped into the SW3_VOLT[5:0], SW3_STBY_VOLT[5:0] and SW3_SLP_VOLT[5:0] register which set the regulator output voltage during Run, Standby and Sleep modes respectively.

Values of SW3_VOLT[5:0], SW3_STBY_VOLT[5:0] and SW3_SLP_VOLT[5:0] are read-only and cannot be written to.

Table 29. SW3 output voltage setting

Set point	SW3_VOLT[3:0] SW3_STBY_VOLT[3:0] SW3_SLP_VOLT[3:0]	Output voltage (V)
0	0000	1.80
1	0001	1.90
2	0010	2.00
3	0011	2.10
4	0100	2.20
5	0101	2.30
6	0110	2.40

Set point	SW3_VOLT[3:0] SW3_STBY_VOLT[3:0] SW3_SLP_VOLT[3:0]	Output voltage (V)
7	0111	2.50
8	1000	2.60
9	1001	2.70
10	1010	2.80
11	1011	2.90
12	1100	3.00
13	1101	3.10
14	1110	3.20
15	1111	3.30

6.3.4 SW3 external components

[Table 30](#) shows the combination of inductor and capacitor values that work with the SW3 regulator.

Table 30. Acceptable inductance and capacitance values

Inductance / capacitance	2 x 10 μ F
1.0 μ H	

[Table 31](#) and [Table 32](#) show example inductor and capacitor part numbers respectively.

Table 31. Example inductor part numbers

Part number	Size (mm)	1.0 μ H
DFE201610E	2.0 x 1.6	57 m Ω , 3.6 A
DFE201610P	2.0 x 1.6	70 m Ω , 3.1 A
DFE201210U	2.0 x 1.2	95 m Ω , 3.1 A
DFE160810S	1.6 x 0.8	120 m Ω , 2.0 A
DFE201208S	2.0 x 1.2	86 m Ω , 2.4 A
DFE160808S	1.6 x 0.8	144 m Ω , 1.9 A

Table 32. Example capacitor part numbers

Murata part number	Description
GRM188R60J106ME47D	6.3 V, 10 μ F, 0402, X5R
GRM188D70J106MA73	6.3 V, 10 μ F, 0402, X7R
GRM188R61A106KE69	10 μ F 10 V 10 % X5R 0603 .95 mm
GRM219R61A106KE44	10 μ F 10 V 10 % X5R 0805 .95 mm

7 Low dropout linear regulators, VREFDDR and VSNVS

7.1 General description

This section describes the LDO regulators provided by the PF1510. All regulators use the main bandgap as reference.

When a regulator is disabled, the output is discharged by an internal pull-down.

VLDO1 and VLDO3 can be used as load switches by setting the corresponding load switch enable bit OTP_VLDOx_LS.

All general purpose LDOs have short-circuit protection capability. The Short-circuit Protection (SCP) system includes debounced fault condition detection, regulator shutdown, and processor interrupt generation, to contain failures and minimize the chance of product damage. If a short-circuit condition is detected and REGSCPEN bit is set, the LDO is disabled by resetting its VLDOxEN bit, while at the same time, an interrupt VLDOxFAULTI is generated to flag the fault to the system processor. The VLDOxFAULTI interrupt is maskable through the VLDOxFAULTM mask bit.

The SCP feature is enabled by setting the REGSCPEN bit. If this bit is not set, the regulators are not automatically disabled upon a short-circuit detection. However, the current limiter continues to limit the output current of the regulator. By default, the REGSCPEN is not set; therefore, at start up none of the regulators are disabled if an overloaded condition occurs. A fault interrupt, VLDOxFAULTI is generated in an overload condition regardless of the state of the REGSCPEN bit. Each LDO features a Low-power mode where the quiescent current consumed is significantly lower than in regulator operation. In the Low-power mode, load current of each regulator is limited to 10 mA.

7.2 LDO1 and LDO3 detailed description

LDO1 and LDO3 are identical 300 mA low dropout (LDO) regulators that provide output voltage with high accuracy and are programmable through I²C interface bits. Being identical, reference is made to these LDOs as LDOy.

To support this wide input range, LDOy circuit incorporates a PMOS pass FET as well as an NMOS pass FET. The LDO uses the main bandgap as its reference.

The regulator incorporates a soft-start circuit that ramps the internal reference in order to provide smooth output waveform with minimal overshooting during power up. When the regulator is disabled, the output is discharged by an internal pull-down resistor. Additionally, the LDO can be used as a load switch by setting the corresponding Load Switch enable bit OTP_LDOy_LS.

Moreover, LDOy includes current limit protection with the option to turn off the LDO when an overcurrent is detected.

7.2.1 Features summary

- Input range LDO from 1.0 V to 4.5 V
- Programmable output voltage between 0.75 V to 1.5 V (uses NMOS) or 1.8 V and 3.3 V (uses PMOS) with 2 % accuracy
- Soft-start ramp control during power up and discharge mechanism during power down
- Low quiescent current (~ 2.5 μ A) at Low-power mode
- Current limit protection

- Configurable into load switch via OTP bit

7.2.2 LDOy block diagram

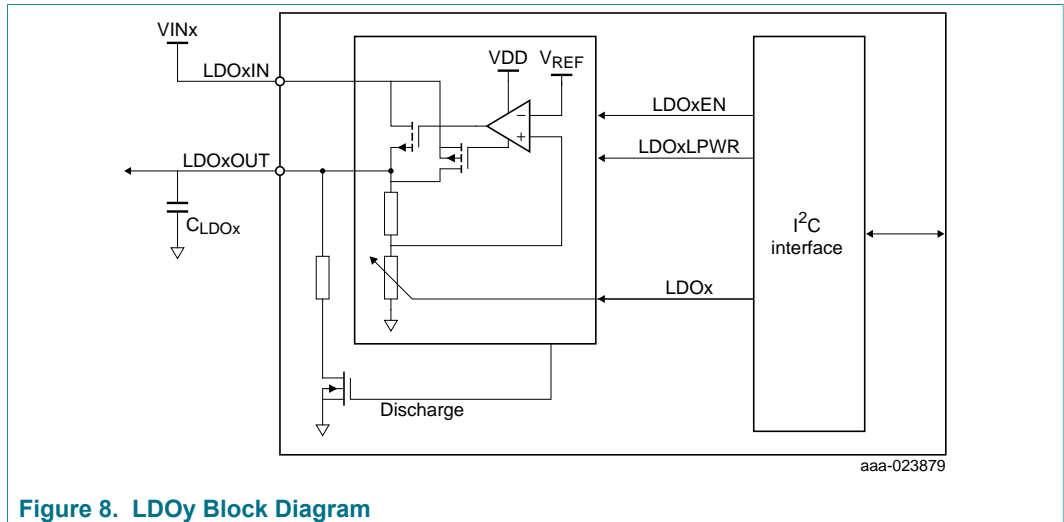

Figure 8. LDOy Block Diagram

7.2.3 LDOy external components

Use a 4.7 μF X5R/X7R capacitor from output to ground with a voltage rating at least 2 times the nominal output voltage.

7.2.4 LDOy output voltage setting

LDOy output voltage is programmed by setting the LDOy[4:0] bits as shown in [Table 33](#).

Table 33. LDOy output voltage setting

Set point	LDOy[4:0]	LDOy output (V)
0	00000	0.7500
1	00001	0.8000
2	00010	0.8500
3	00011	0.9000
4	00100	0.9500
5	00101	1.0000
6	00110	1.0500
7	00111	1.1000
8	01000	1.1500
9	01001	1.2000
10	01010	1.2500
11	01011	1.3000
12	01100	1.3500
13	01101	1.4000
14	01110	1.4500

Set point	LDOy[4:0]	LDOy output (V)
15	01111	1.5000
16	10000	1.8000
17	10001	1.9000
18	10010	2.0000
19	10011	2.1000
20	10100	2.2000
21	10101	2.3000
22	10110	2.4000
23	10111	2.5000
24	11000	2.6000
25	11001	2.7000
26	11010	2.8000
27	11011	2.9000
28	11100	3.0000
29	11101	3.1000
30	11110	3.2000
31	11111	3.3000

7.2.5 LDOy low power mode operation

LDOy can operate in a Low-power mode with reduced quiescent current. The Low-power mode can be activated in Standby and Sleep modes by setting the LDOy_LPWR bit as shown in [Table 34](#). Maximum load current is limited to 10 mA when operating in the Low-power mode.

Table 34. LDOy control bits

PMIC state	LDOy_EN	LDOy_STBY	LDOy_OMODE	LDOy_LPWR	LDOy operating mode
Run/Standby/Sleep	0	X	X	X	LDO disabled
Run	1	X	X	X	LDO enabled
Standby	1	0	X	X	LDO disabled
Standby	1	1	X	0	LDO enabled
Standby	1	1	X	1	LDO enabled in Low-power mode
Sleep	1	X	0	X	LDO disabled
Sleep	1	X	1	0	LDO enabled
Sleep	1	X	1	1	LDO enabled in Low-power mode

7.2.6 LDOy current limit protection

LDOy has built in current limit protection. When the load current exceeds the current limit threshold, the regulator goes from a voltage regulation mode to a current regulation mode that limits the available output current.

By setting the REGSCPEN bit, LDOy can be automatically disabled in the event of an over current situation. In the event of an over current, the LDO will be disabled by resetting its LDOy_EN bit, while at the same time an interrupt LDOy_FAULTI is generated to flag the fault to the system processor. The LDOy_FAULTI interrupt is maskable through the LDOy_FAULTM mask bit.

If REGSCPEN is not set, the regulator will not be automatically disabled, but will instead enter the current limit mode. By default, the REGSCPEN is not set; therefore, at start-up none of the regulators will be disabled if an overloaded condition occurs. A fault interrupt, LDOy_FAULTI, is generated in an overload condition regardless of the state of the REGSCPEN bit.

Current limit is not active when LDOy is operated in the load switch mode.

7.2.7 LDOy load switch mode

The LDOy path can be turned into a switch by setting the OTP_LDOy_LS bit. Setting this bit fully turns on the LDO pass FET. This could be useful if power domain partitioning or additional isolation is needed on the system application. Soft-start is engaged during start up of the load switch to reduce inrush currents.

7.3 LDO2 detailed description

LDO2 is a 400 mA low dropout (LDO) regulator that provides output voltage with high accuracy and programmable through I²C/ interface bits. To support this wide input range the LDO circuit incorporates a PMOS pass FET. The LDO uses the main bandgap as its reference.

The regulator incorporates a soft-start circuit that ramps the internal reference in order to provide smooth output waveform with minimal overshooting during power up. When the regulator is disabled, the output is discharged by an internal pull-down resistor. The pull-down is also activated when RESETBMCU is low.

Moreover, LDO2 includes current limit protection with option to turn off the LDO when an overcurrent is detected.

7.3.1 LDO2 features summary

- Input range LDO from 2.8 V to 4.5 V
- Programmable output voltage between 1.8 V and 3.3 V with 2 % accuracy
- Soft-start ramp control during power up and discharge mechanism during power down
- Low quiescent current (~ 1.5 μ A) at Low-power mode
- Current limit protection

7.3.2 LDO2 block diagram

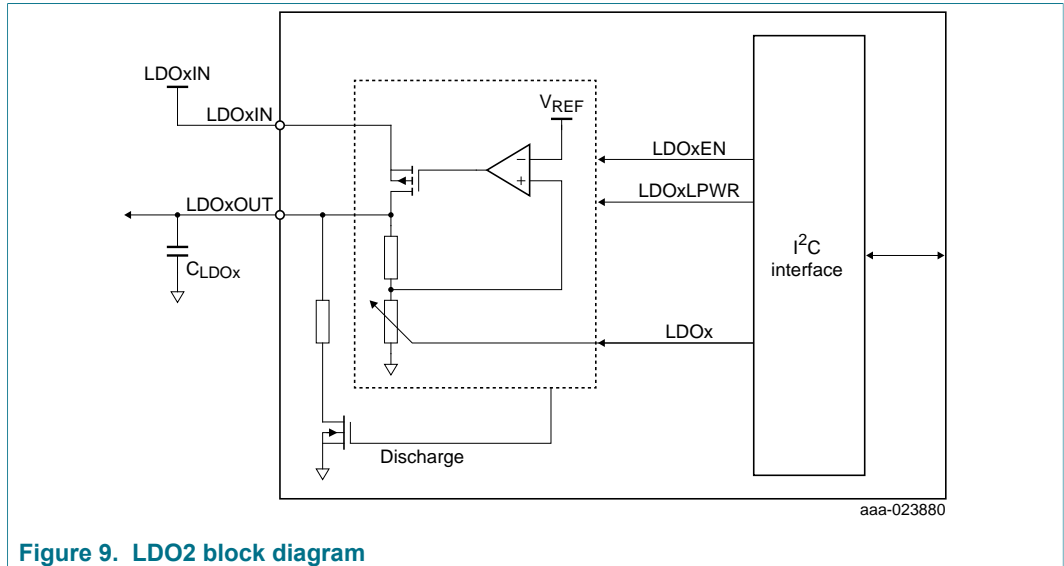

Figure 9. LDO2 block diagram

7.3.3 LDO2 external components

Use a 10 µF X5R/X7R capacitor from output to ground with a voltage rating at least 2 times the nominal output voltage.

7.3.4 LDO2 output voltage setting

LDO2 output voltage is programmed by setting the VLDO2[3:0] bits as shown in [Table 35](#).

Table 35. LDO2 output voltage setting

Set point	VLDO2[3:0]	VLDO2 output (V)
0	0000	1.80
1	0001	1.90
2	0010	2.00
3	0011	2.10
4	0100	2.20
5	0101	2.30
6	0110	2.40
7	0111	2.50
8	1000	2.60
9	1001	2.70
10	1010	2.80
11	1011	2.90
12	1100	3.00
13	1101	3.10
14	1110	3.20

Set point	VLDO2[3:0]	VLDO2 output (V)
15	1111	3.30

7.3.5 LDO2 Low-power mode operation

LDO2 can operate in a Low-power mode with reduced quiescent current. The low power mode can be activated in Standby and Sleep modes by setting the LDO2LPWR bit as shown in [Table 36](#). Maximum load current is limited to 10 mA when operating in the Low-power mode.

Table 36. LDO2 control bits

PMIC state	LDO2EN	LDO2STBY	LDO2OMODE	LDO2LPWR	LDO2 operating mode
Run	0	X	X	X	LDO disabled
Run	1	X	X	X	LDO enabled
Standby	1	0	X	X	LDO disabled
Standby	1	1	X	0	LDO enabled
Standby	1	1	X	1	LDO enabled in Low-power mode
Sleep	1	X	0	X	LDO disabled
Sleep	1	X	1	0	LDO enabled
Sleep	1	X	1	1	LDO enabled in Low-power mode

7.3.6 LDO2 current limit protection

LDO2 has built in current limit protection. When the load current exceeds the current limit threshold, the regulator goes from a voltage regulation mode to a current regulation mode limiting the available output current.

By setting the REGSCPEN bit, LDO2 can be automatically disabled in the event of an over current situation. In the event of an over current, the LDO is disabled by resetting its VLDO2EN bit, while at the same time an interrupt VLDO2FAULTI is generated to flag the fault to the system processor. The VLDO2FAULTI interrupt is maskable through the VLDO2FAULTM mask bit.

If REGSCPEN is not set, the regulator will not be automatically disabled, but instead enter the current limit mode. By default, the REGSCPEN is not set; therefore, at start-up none of the regulators will be disabled if an overloaded condition occurs. A fault interrupt, VLDO2FAULTI is generated in an overload condition regardless of the state of the REGSCPEN bit.

7.4 VREFDDR reference

VREFDDR is an internal NMOS half supply voltage follower capable of supplying up to 10 mA. The output voltage is at one half the input voltage. It is typically used as the reference voltage for DDR memories.

A filtered resistor divider is utilized to create a low frequency pole. This divider then utilizes a voltage follower to drive the load.

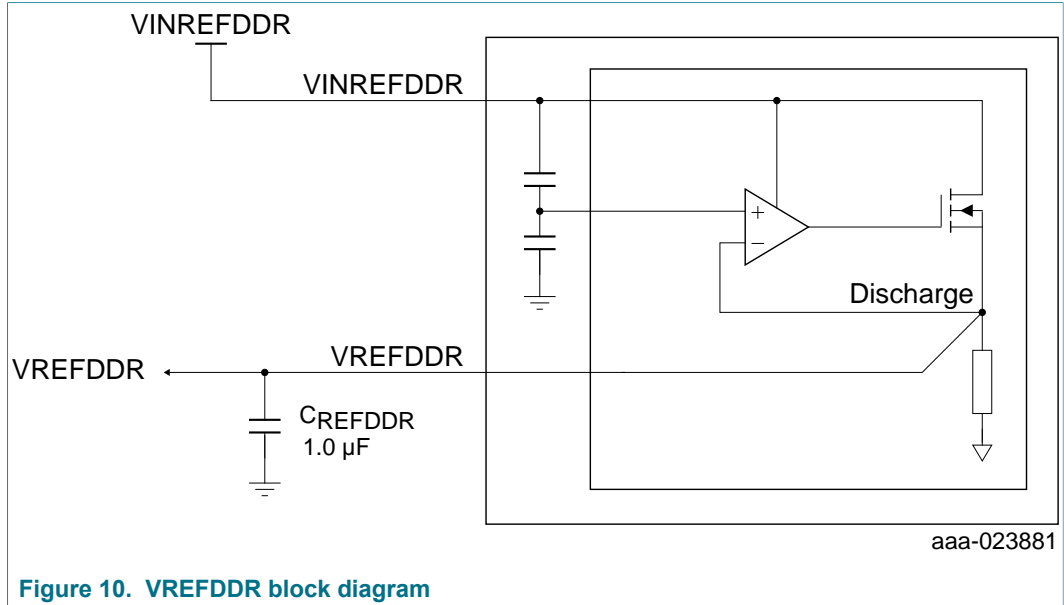

Figure 10. VREFDDR block diagram

7.5 VSNVS LDO/Switch

VSNVS powers the low-power SNVS/RTC domain on the processor. It derives its power from either VSYS or a coin cell. When powered by both, VSYS powers VSNVS if VSYS > VTH threshold and LICELL powers VSNVS when VSYS < VTL. When powered by VSYS, VSNVS is an LDO capable of supplying 2.0 mA at 3.0 V. When powered by coin cell, VSNVS output tracks the coin cell voltage by means of a switch. In this case, the VSNVS voltage is simply the coin cell voltage minus the voltage drop across the switch.

Upon subsequent removal of VSYS, with the coin cell attached, VSNVS will change configuration from an LDO to a switch.

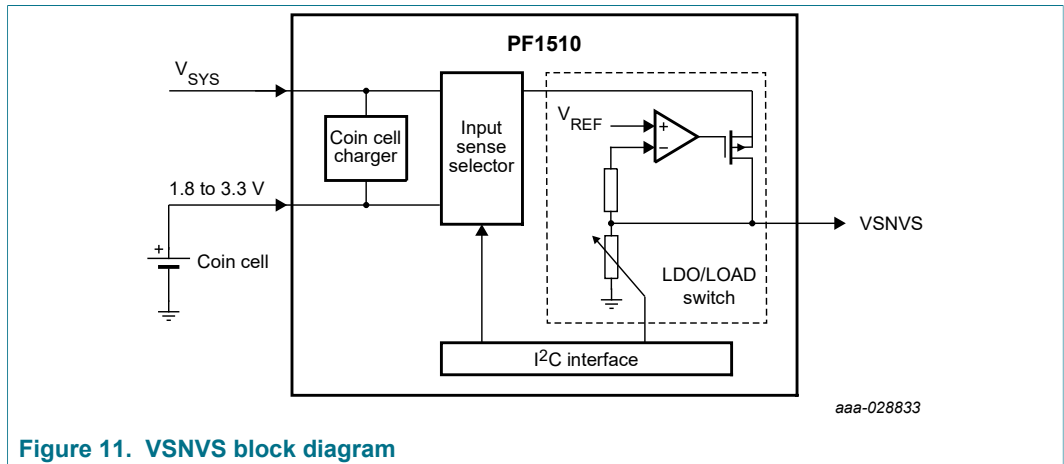

Figure 11. VSNVS block diagram

8 Front-end LDO description

The VIN operates from 4.0 V to 6.5 V with up to 22 V overvoltage protection.

The VIN current limit works by monitoring the current being drawn from the VIN and comparing it to the programmed current limit. The current limit should be set based on the current-handling capability of the input adaptor. Generally, this limit is chosen to optimally fulfill the system-power requirements. See [Table 40](#).

The PMIC is powered from the VSYS node in the PF1510.

The VSYS voltage can be regulated to either 3.5 V, 3.7 V or 4.3 V. See [Table 38](#).

8.1 Operating modes and behavioral description

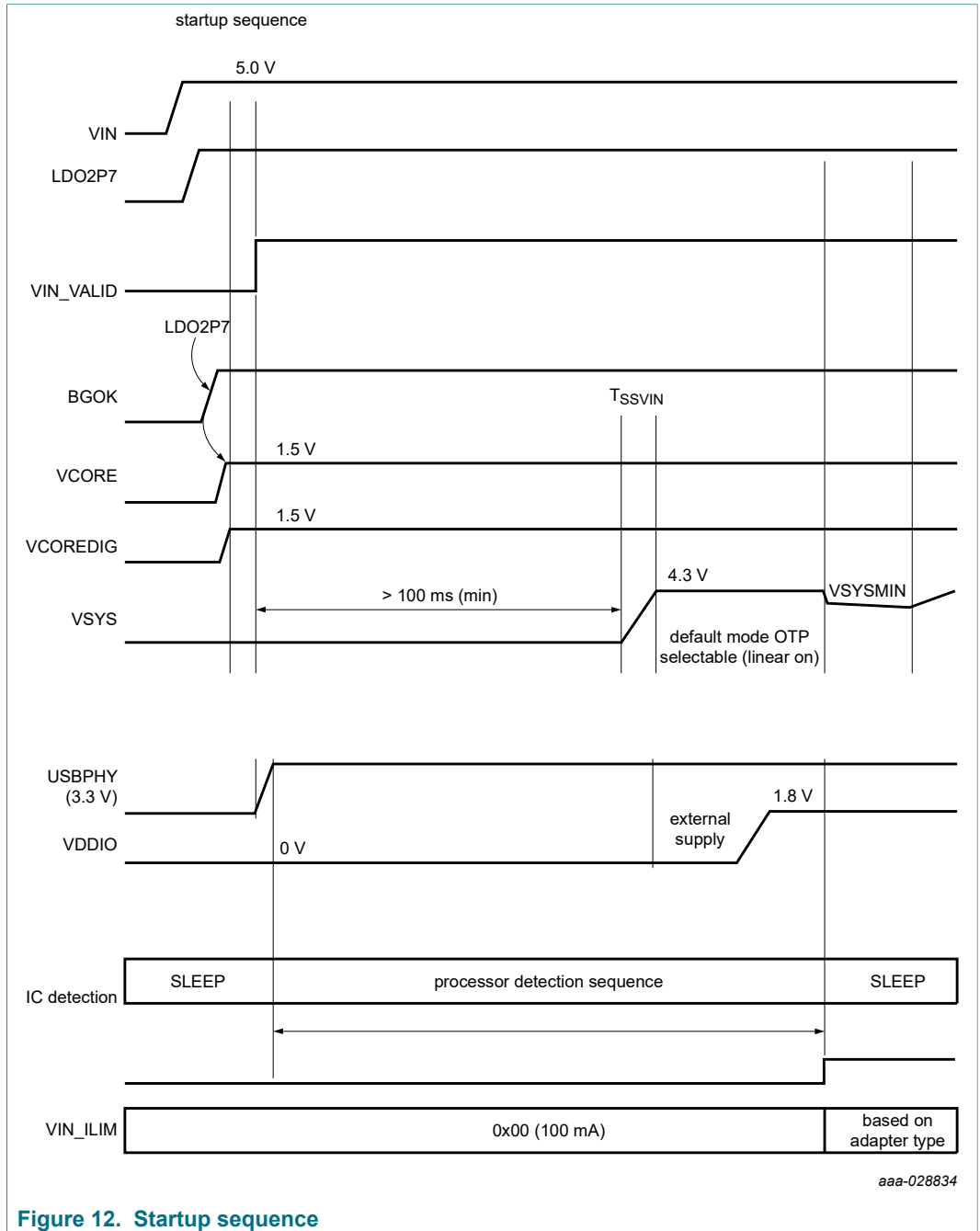

Figure 12. Startup sequence

Table 37. Front-end regulator register

FRONT-END REGULATOR REGISTER								
ADDR:	0x8F							
	D7	D6	D5	D4	D3	D2	D1	D0
BITS:	VSYSTEMIN		Reserved					
POR:	0	0	1	0	1	0	1	1

FRONT-END REGULATOR REGISTER

ACCESS:								
---------	--	--	--	--	--	--	--	--

The VSYS_{MIN} value is programmable via OTP as per the table below.

Table 38. VSYS_{MIN} setting

VSYS _{MIN} [1:0] setting	VSYS _{MIN} setting (V)
00	3.5
01	3.7
10	4.3
11	Reserved

The VSYS_{MIN} setting is the "normal" regulation point for VSYS. This parameter sets the point where the VSYS loop starts taking control and regulates the output. 4.3 V is the recommended setting to ensure that there is enough headroom before reaching UVDET (PMIC undervoltage detection, 2.9 V typ.).

Typically, the VSYS output range can go as low as 300 mV below the VSYS_{MIN} setting. Therefore, the recommended setting for the VSYS output should be between 4.0 V to 4.3 V.

Table 39. VIN current limit register

VIN CURRENT LIMIT REGISTER								
ADDR:	0x94							
	D7	D6	D5	D4	D3	D2	D1	D0
BITS:	VIN_ILIM					RESERVED		
POR:	0	1	1	0	1	0	0	0
ACCESS:	R/W	R/W	R/W	R/W	R/W	—		

The table below shows valid VIN limit settings.

Table 40. VIN limit settings

VIN_ILIM[4:0] setting	VIN current limit (mA)
00000	10
00001	15
00010	20
00011	25
00100	30
00101	35
00110	40
00111	45
01000	50
01001	100
01010	150
01011	200

VIN_ILIM[4:0] setting	VIN current limit (mA)
01100	300
01101	400
01110	500
01111	600
10000	700
10001	800
10010	900
10011	1000
10100	1500
10101 to 11101	Reserved
11110	Reserved
11111	Reserved

9 Control and interface signals

The PF1510 PMIC is fully programmable via the I²C interface. Additional communication is provided by direct logic interfacing including interrupt and reset pins as well as pins for power buttons.

9.1 PWRON

PWRON is an input signal to the IC that acts as an enable signal for the voltage regulators in the PF1510.

The PWRON pin can be configured as either a level sensitive input (OTP_PWRON_CFG = 0), or as an edge sensitive input (OTP_PWRON_CFG = 1).

As a level sensitive input, an active high signal turns on the part and an active low signal turns off the part, or puts it into Sleep mode.

As an edge sensitive input, such as when connected to a mechanical switch, a falling edge will turn on the part and if the switch is held low for greater than or equal to 4.0 seconds, the part turns off or enters Sleep mode.

Table 41. PWRON pin OTP configuration options

OTP_PWRON_CFG	Mode
0	PWRON pin HIGH = ON PWRON pin LOW = OFF or Sleep mode
1	PWRON pin pulled LOW momentarily = ON PWRON pin LOW for 4.0 seconds = OFF or Sleep mode

Table 42. PWRON pin logic level

Pin name	Parameter	Load condition	Min	Max	Unit
PWRON	V _{IL}	—	0.0	0.4	V

Power management integrated circuit (PMIC) for low power application processors

Pin name	Parameter	Load condition	Min	Max	Unit
	V _{IH}	—	1.4	3.6	V

When OTP_PWRON_CFG = 1, PWRON pin pulled low momentarily takes the system from REGS_DISABLE/SLEEP to RUN mode. There is no effect if PWRON is pulled low momentarily while in RUN or STANDBY modes. Only an interrupt is generated.

PWRON pin low for 4.0 seconds with PWRONRSTEN bit = 1: Enters REGS_DISABLE or Sleep mode.

See [Section 10 "PF1510 state machine"](#) for detailed description.

In this configuration, the PWRON input can be a mechanical switch debounced through a programmable de-bouncer, PWRONDBNC[1:0], to avoid a response to a very short key press. The interrupt is generated for both the falling and the rising edge of the PWRON pin. By default, a 31.25 ms interrupt debounce is applied to both falling and rising edges. The falling edge debounce timing can be extended with PWRONDBNC[1:0]. The interrupt is cleared by software, or when cycling through the REGS_DISABLE mode.

Table 43. PWRONDBNC settings

Bits	State	Turn on debounce (ms)	Falling edge INT debounce (ms)	Rising edge INT debounce (ms)
PWRONDBNC[1:0]	00	31.25	31.25	31.25
	01	31.25	31.25	31.25
	10	125	125	31.25
	11	750	750	31.25

9.2 STANDBY

STANDBY is an input signal to the IC. When it is asserted the part enters standby mode and when deasserted, the part exits standby mode. STANDBY can be configured as active high or active low using the STANDBYINV bit.

Table 44. Standby pin polarity control

STANDBY (pin)	STANDBYINV (I ² C bit)	STANDBY control
0	0	Not in Standby mode
0	1	In Standby mode
1	0	In Standby mode
1	1	Not in Standby mode

Table 45. STANDBY pin logic level

Pin name	Parameter	Load condition	Min	Max	Unit
STANDBY	V _{IL}	—	0	0.4	V
	V _{IH}	—	1.4	3.6	V

Since STANDBY pin activity is driven asynchronously to the system, a finite time is required for the internal logic to qualify and respond to the pin level changes. A programmable delay is provided to hold off the system response to a Standby event. This

allows the processor and peripherals some time after a standby instruction has been received to terminate processes to facilitate seamless entering into Standby mode. When enabled (STANDBYDLY = 01, 10, or 11), STANDBYDLY delays the Standby initiated response for the entire IC, until the STBYDLY counter expires. An allowance should be made for three additional 32 kHz cycles required to synchronize the Standby event.

9.3 RESETBMCU

RESETBMCU is an open-drain, active low output configurable via OTP for two modes of operation.

In its default mode, it is deasserted at the end of the start-up sequence. In this mode, the signal can be used to bring the processor out of reset (POR), or as an indicator that all supplies have been enabled; it is only asserted during a turn off event.

When configured for its fault mode, RESETBMCU is deasserted after the startup sequence is completed only if no faults occurred during start up. At any time, if a fault occurs and persists for 1.8 ms typically, RESETBMCU is asserted low.

The PF1510 is turned off if the fault persists for more than 100 ms typically. The PWRON signal restarts the part, though if the fault persists, the sequence described above is repeated. To enter the fault mode, set bit OTP_PWRGD_EN to 1.

The time from the last regulator in the start-up sequence to when RESETBMCU is deasserted is programmable between 2.0 ms and 1024 ms via OTP_POR_DLY[2:0] bits.

Table 46. RESETBMCU pin logic level

Pin name	Parameter	Load condition	Min	Max	Unit
RESETBMCU	V _{OL}	-2.0 mA	0	0.2 * VDDIO	V
	V _{OH}	Open Drain	0.8 * VDDIO	3.6 V	V

9.4 INTB

INTB is an open-drain, active low output. It is asserted when any interrupt occurs, provided that the interrupt is unmasked. INTB is deasserted after the fault interrupt is cleared by software, which requires writing a “1” to the interrupt bit.

Each interrupt can be masked by setting the corresponding mask bit to a 1. As a result, when a masked interrupt bit goes high, the INTB pin does not go low. A masked interrupt can still be read from the interrupt status register. This gives the processor the option of polling for status from the IC.

The IC powers up with all interrupts masked, so the processor must initially poll the device to determine if any interrupts are active. Alternatively, the processor can unmask the interrupt bits of interest. If a masked interrupt bit was already high, the INTB pin goes low after unmasking. The sense registers contain status and input sense bits so the system processor can poll the current state of interrupt sources. They are read only, and not latched or clearable.

Table 47. INTB pin logic level

Pin name	Parameter	Load condition	Min	Max	Unit
INTB	V _{OL}	-2.0 mA	0	0.2 * VDDIO	V
	V _{OH}	Open Drain	0.8 * VDDIO	3.6 V	V

9.5 WDI

WDI is an input signal to the IC. It is typically connected to the watchdog output of the processor. When the WDI pin is pulled low, the PMIC enters the “REGS_DISABLE” mode where all the regulators are turned off. The WDI acts as a hard reset input from the processor.

During PMIC startup (REGS_DISABLE to RUN mode), the WDI pin is masked till RESETBMCU is deasserted.

Table 48. WDI pin logic level

Pin name	Parameter	Load condition	Min	Max	Unit
WDI	V _{IL}	—	0	0.2 * VDDIO	V
	V _{IH}	—	0.8 * VDDIO	3.6	V

9.6 ONKEY

ONKEY is an input pin to the IC and is typically connected to a push-button switch. The ONKEY pin is pulled high when the switch is depressed, and is pulled low when the switch is pressed.

Pressing the switch generates interrupts which the processor uses to initiate PMIC state transitions. Pressing the ONKEY for longer than the delay programmed by OTP_TGRESET[1:0] (ranges from 4.0 s to 16 s), forces the PMIC into the REGS_DISABLE state.

Table 49. ONKEY pin logic level

Pin name	Parameter	Load condition	Min	Max	Unit
ONKEY	V _{IL}	—	0	0.4	V
	V _{IH}	—	1.4	4.8	V

Table 50. ONKEYDBNC settings

Bits	State	Turn On Debounce (ms)	Falling Edge INT Debounce (ms)	Rising Edge INT Debounce (ms)
ONKEYDBNC[1:0]	00	31.25	31.25	31.25
	01	31.25	31.25	31.25
	10	125	125	31.25
	11	750	750	31.25

The ONKEY input can be a mechanical switch debounced through a programmable debouncer, ONKEYDBNC[1:0], to avoid a response to a very short (unintentional) key press. The interrupt is generated during the rising edge of the ONKEY pin.

The falling edge debounce timing can be extended with ONKEYDBNC[1:0] as defined [Table 50](#). The interrupt is cleared by software, or when cycling through the REGS_DISABLE mode.

See [Section 12 "Register map"](#) for detailed description of the ONKEY interrupt registers.

9.7 Control interface I²C block description

The PF1510 contains an I²C interface port which allows access by a processor, or any I²C master, to the register set. Via these registers, the resources of the IC can be controlled. The registers also provide status information about how the IC is operating.

The SCL and SDA lines should be routed away from noisy signals and planes to minimize noise pick up. To prevent reflections in the SCL and SDA traces from creating false pulses, the rise and fall times of the SCL and SDA signals must be greater than 20 ns. This can be accomplished by reducing the drive strength of the I²C master via software.

9.7.1 I²C device ID

I²C interface protocol requires a device ID for addressing the target IC on a multi-device bus. The PF1510 I²C device address is 0x08.

9.7.2 I²C operation

The I²C mode of the interface is implemented generally following the fast mode definition which supports up to 400 kbits/s operation (exceptions to the standard are noted to be 7-bit only addressing and no support for general call addressing). Timing diagrams, electrical specifications, and further details can be found in the I²C specification, which is available for download at:

http://www.nxp.com/acrobat_download/literature/9398/39340011.pdf

I²C read operations are also performed in byte increments separated by an ACK. Read operations also begin with the MSB and each byte is sent out unless a STOP command or NACK is received prior to completion.

The following examples show how to write and read data to and from the IC. The host initiates and terminates all communication. The host sends a master command packet after driving the start condition. The device responds to the host if the master command packet contains the corresponding slave address. In the following examples, the device is shown always responding with an ACK to transmissions from the host. If at any time a NACK is received, the host should terminate the current transaction and retry the transaction.

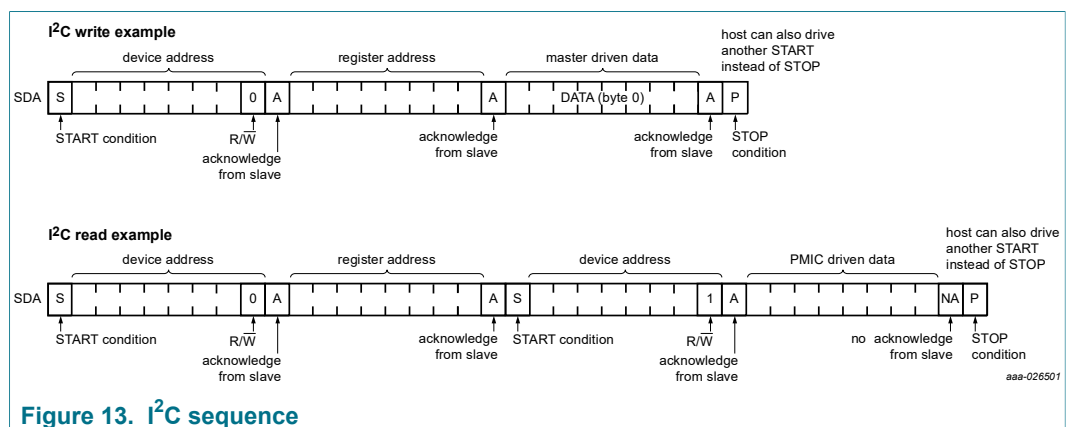

Figure 13. I²C sequence

10 PF1510 state machine

The PMIC part of the PF1510 can operate in a number of states as shown in [Figure 14](#).

The states can be split into two categories:

1. “System On” that includes the RUN, STANDBY and SLEEP modes
2. “System Off” that includes the REGS_DISABLE and CORE_OFF modes

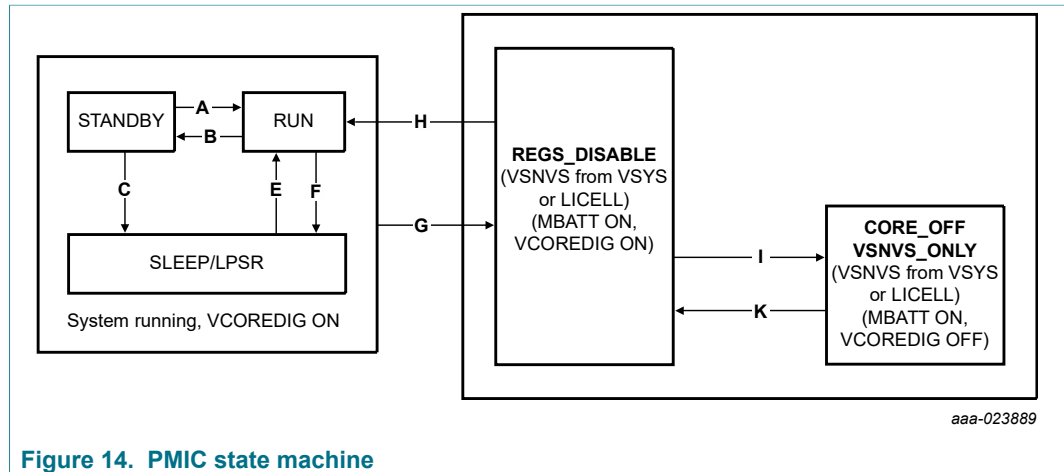

Figure 14. PMIC state machine

In the “System On” modes, some or all of the PMIC regulators are powered and in general the system processor is powered.

In the “System Off” modes, all (or all regulators except VSNVS) are powered off. In general the system processor is powered off during these states. In the REGS_DISABLE and CORE_OFF modes, the VSNVS supply remains enabled keeping the system RTC running.

The only way to transition from “System Off” to “System On” and vice versa is through the REGS_DISABLE mode. From the REGS_DISABLE mode, the only exit into a “System On” state is into the “Run” mode. Transition from the REGS_DISABLE mode to the Run mode requires a Turn On event. See [Section 10.3 "Turn on events"](#).

Transition from any of the “System On” modes to the REGS_DISABLE state is allowed. This transition is referred to as a Turn Off event. See [Section 10.4 "Turn off events"](#).

10.1 System ON states

10.1.1 Run state

In this state, the PMIC regulators are enabled and the system is powered up. RESETBMCU is de-asserted in this state.

This mode can be entered in several ways:

1. From REGS_DISABLE through a Turn On Event: During this transition, the PMIC regulators are powered up as per their programmed start-up sequence. After all the regulators are powered, the RESETBMCU pin is de-asserted.
2. From STANDBY by using the STANDBY pin
3. From SLEEP mode by using the PWRON pin: Typically, some of the regulators are turned off in the SLEEP mode compared to the RUN mode. In the SLEEP mode, some of the buck regulator output voltages are set lower than those in the RUN

mode. While transitioning from the SLEEP to the RUN mode, regulators that were turned off in the SLEEP mode are turned back on in the RUN mode following the same sequence as the programmed OTP sequence. Output voltage transitions during transition from the SLEEP to the RUN mode also occurs at the same OTP sequence time slot. RESETBMCU is de-asserted through this state transition.

10.1.2 STANDBY state

This state is entered by controlling the logic level of the STANDBY pin. It can be entered only from the RUN mode.

The STANDBY pin polarity is programmable through the STANDBYINV I²C bit. By default, STANDBYINV = 0 and a logic high on the STANDBY pin moves the state machine from the RUN state to the STANDBY state. When STANDBYINV = 1, a logic low moves the state machine from the RUN state to the STANDBY state.

Regulator output voltage may be changed, or regulator outputs could be disabled while entering the STANDBY state and vice versa.

For details on the power-down sequence, see [Section 10.7 "Regulator power-down sequencer"](#). While exiting STANDBY state into the RUN mode, regulator output voltage changes and regulator enables follow the power-up sequence.

It is possible to exit STANDBY state and enter the SLEEP state. SLEEP state is generally a lower power system state compared to the STANDBY state. Exiting STANDBY into the SLEEP state follows the power-down sequence.

RESETBMCU is de-asserted in the STANDBY state.

10.1.3 SLEEP state

This state is entered from either the RUN state or the STANDBY state by controlling the PWRON pin. The exact condition required for this transition depends on the OTP configuration of the PWRON pin. For details see [Section 9.1 "PWRON"](#).

The power-down sequence is followed while entering this state and the power-up sequence is followed while exiting this state into the RUN state.

RESETBMCU is de-asserted in the SLEEP state.

10.2 System OFF states

RESETBMCU is asserted (low) in all the System Off states.

10.2.1 REGS_DISABLE

This state can be considered the 'home state' for the state machine. In this state, the state machine waits for appropriate commands to proceed to other states.

REGS_DISABLE can be entered from one of the "System On" state through a turn off event.

REGS_DISABLE can be entered from the CORE_OFF by pressing the ONKEY button for more than 1000 ms or by applying the Vin.

In the REGS_DISABLE state, the PMIC core circuitry is active. VSNVS is a best-of-supply output of VSYS and LICELL.

10.2.2 CORE_OFF

This state is entered in two ways:

1. From the REGS_DISABLE mode by pressing and holding the ONKEY button low > T_{greset}
2. From the REGS_DISABLE mode if the GOTO_CORE_OFF bit is set

This state cannot be entered if V_{in} is applied.

In this state, the internal core of the PMIC is turned off to reduce quiescent current. VSNVS is the only regulator that is supplied to external loads.

10.3 Turn on events

A turn on event takes the PMIC from the REGS_DISABLE state to the RUN state (transition H in [Figure 14](#)).

The turn on events are:

1. PWRON logic high with PWRON_CFG = 0
2. PWRON H -> L with PWRON_CFG = 1

$V_{\text{SYS}} > UVDET_{\text{rising}}$ and $T_{\text{J}} < T_{\text{SHDN_fall}}$ are preconditions for a turn on event to occur.

The turn on is said to be complete after the RESETBMCU pin is deasserted. The WDI pin is masked till the RESETBMCU pin is deasserted.

10.4 Turn off events

A turn off event takes the PMIC state machine from one of the “System On” states (RUN, STANDBY or SLEEP) to the REGS_DISABLE state. The power-down sequence is followed during all of the turn off events.

The turn off events are:

1. Thermal Shutdown ($T_{\text{J}} > T_{\text{SHDN_rise}}$)
2. PWRON logic low with OTP_PWRON_CFG = 0
3. PWRON low > 4.0 s with OTP_PWRON_CFG = 1 && PWRONRSTEN = 1
4. WDI = 0. This occurs when the processor watchdog expires and pulls the WDI pin low to create a hard reset.
5. ONKEY pressed low > T_{greset} && ONKEYRST_EN = 1. This facilitates creating a hard reset when pressing the ONKEY button without processor intervention.

10.5 State diagram and transition conditions

Table 51. State transition table

Transition	Description	PWRON_CFG = 0 (Level sensitive)	PWRON_CFG = 1 (Edge sensitive)
A	Standby to Run	(STANDBY pin = 0 && STANDBYINV bit = 0) OR (STANDBY pin = 1 && STANDBYINV bit = 1)	(STANDBY pin = 0 && STANDBYINV bit = 0) OR (STANDBY pin = 1 && STANDBYINV bit = 1)
B	Run to Standby	(STANDBY pin = 1 && STANDBYINV bit = 0) OR (STANDBY pin = 0 && STANDBYINV bit = 1)	(STANDBY pin = 1 && STANDBYINV bit = 0) OR (STANDBY pin = 0 && STANDBYINV bit = 1)
C	Standby to Sleep	(PWRON = 0) && (Any SWxOMODE = 1 Any LDOxOMODE = 1)	(PWRON High to Low and PWRON = 0 > 4s) && (PWRONRSTEN = 1) && (Any SWxOMODE = 1 Any LDOxOMODE = 1)

Power management integrated circuit (PMIC) for low power application processors

Transition	Description	PWRON_CFG = 0 (Level sensitive)	PWRON_CFG = 1 (Edge sensitive)
E	Sleep to Run	PWRON = 1	PWRON High to Low to High ^[1]
F	Run to Sleep	(PWRON = 0) && (Any SWxOMODE = 1 Any LDOxOMODE = 1)	(PWRON High to Low and PWRON = 0 > 4s) && (PWRONRSTEN = 1) && (Any SWxOMODE = 1 Any LDOxOMODE = 1)
G	Run/Standby/Sleep to REGS_DISABLE	(Thermal shutdown) OR (PWRON = 0 && All SWxOMODE = 0 && All LDOxOMODE = 0) OR (WDI = 0) ^[2] OR (ONKEY High to Low and ONKEY = 0 > Tgreset && ONKEY_RST_EN = 1) OR (VSYS < UVDET_Fall) ^[3]	(Thermal shutdown) OR (PWRON = 0 > 4s && PWRONRSTEN = 1 && All SWxOMODE = 0 && All LDOxOMODE = 0) OR (PWRON High to Low and PWRON = 0 > 4s when in Sleep state) OR (WDI = 0) ^[2] OR (ONKEY High to Low and ONKEY = 0 > Tgreset and ONKEY_RST_EN = 1) OR (VSYS < UVDET_Fall) ^[3]
H	REGS_DISABLE to Run (Only if VSYS > UVDET and T _J < T _{SHDN_fail})	PWRON = 1	(PWRON High to Low) OR (If entered REGS_DISABLE via long press on PWRON && RESTARTEN = 1 && PWRON stays Low > 1.0 s) OR (Vin applied) ^{[4] [5]}
I	REGS_DISABLE to CORE_OFF (Only if VIN_INVALID = 1)	(GOTO_CORE_OFF = 1 && ONKEY = 1) OR (ONKEY High to Low and ONKEY = 0 > Tgreset && ONKEY_RST_EN = 1) ^{[6][7]}	(GOTO_CORE_OFF = 1 && ONKEY = 1) OR (ONKEY High to Low and ONKEY = 0 > Tgreset && ONKEY_RST_EN = 1) ^{[6][8]}
K	CORE_OFF to REGS_DISABLE	(ONKEY High to Low and ONKEY = 0 > 1000 ms) OR (Vin applied)	(ONKEY High to Low and ONKEY = 0 > 1000 ms) OR (Vin applied)

[1] This low period is < 4.0 s. If it is longer than 4.0 s, it transitions to G
 [2] PWRON pin is pulled low by processor after WDI = 0.
 [3] Follows regulator power-down sequence for this transition
 [4] WDI pin is masked till RESETBMCU is deasserted.
 [5] Debounce on PWRON programmable via PWRONDBNC[1:0]
 [6] PWRON pin is pulled low by processor after ONKEY = 0 > Tgreset.
 [7] GOTO_CORE_OFF is set by user when system is ON. For other products, a secondary processor is used to set this bit while in REGS_DISABLE
 [8] GOTO_CORE_OFF must be set by user when system is ON

10.6 Regulator power-up sequencer

Start-up sequence of all the switching and linear regulators in the PF1510 is programmable. VSNVS's sequence is not programmable but is always the first regulator to power up when the PF1510 is powered up via a cold start (from no input to valid input). When SYS is first applied to the PF1510, VSNVS comes up first.

The switching and linear regulators power up based on their programmed OTP sequence using the respective OTP_XX_SEQ[2:0] when transitioning from REGS_DISABLE to the RUN state.

RESETBMCU is pulled low from VCOREDIG POR till the end of the power-up sequencer.

RESETBMCU is pulled high 2.0 ms to 1024 ms after the last regulator powers up. This delay is OTP programmable through the OTP_POR_DLY[2:0] bits.

When transitioning from STANDBY mode to RUN mode, the power-up sequencer is activated only if any of the regulators turn back on during this transition.

The power-up sequencer ends as soon as the last regulator powers up, rather than waiting for a fixed time.

The power-up sequencer is always activated when transitioning from Sleep to Run modes. The sequencer ends as soon as the last regulator powers up, rather than waiting for a fixed time.

The PWRUP_I interrupt is set to indicate completion of transition from STANDBY to RUN and SLEEP to RUN.

The PWRUP_I interrupt is set while transitioning from STANDBY to RUN even if the sequencers were not used. This is used to indicate that the transition is complete.

10.7 Regulator power-down sequencer

The power-down sequencer performs the functional opposite to the power-up sequencer. Each regulator has an associated register setting (SW1_PWRDN_SEQ[2:0], SW2_PWRDN_SEQ[2:0], SW3_PWRDN_SEQ[2:0], LDO1_PWRDN_SEQ[2:0], LDO2_PWRDN_SEQ[2:0], LDO3_PWRDN_SEQ[2:0], VREFDDR_PWRDN_SEQ[2:0]) that sets its power-down sequence.

The default setting of the above registers is equal to the corresponding power-up sequence setting. For example, SW1_PWRDN_SEQ[2:0] = OTP_SW1_PWRUP_SEQ[2:0].

When the power-down sequencer is activated, regulators are turned off one by one in the descending order of the XXX_PWRDN_SEQ[2:0] setting. This way, by default power-down is a mirror of the power-up sequence.

In one of the "System On" states, the processor can change the values of the XXX_PWRDN_SEQ[2:0] registers. The power-up sequence is fixed by OTP (or TBB). If all XXX_PWRDN_SEQ[2:0] = 0x00, the power-down sequencer is bypassed and all the regulators are turned off at once. During transition from Run to Standby, the power-down sequencer is activated if any of the regulators are turned off during this transition.

If regulators are not turned off during this transition, the power-down sequencer is bypassed and the transition happens at once (any associated DVS transitions still take time).

During transition from Run to Sleep, the power-down sequencer is always activated. However, if all XXX_PWRDN_SEQ[2:0] = 0, the transition happens immediately.

The PWRDN_I interrupt is set during transition from Run to Sleep and Run to Standby even if regulators are not turned off during these transitions.

11 Device start up

11.1 Startup timing diagram

The startup timing of the regulators is programmable through OTP, [Figure 15](#) shows the startup timing of the regulators as determined by their OTP A4 sequence.

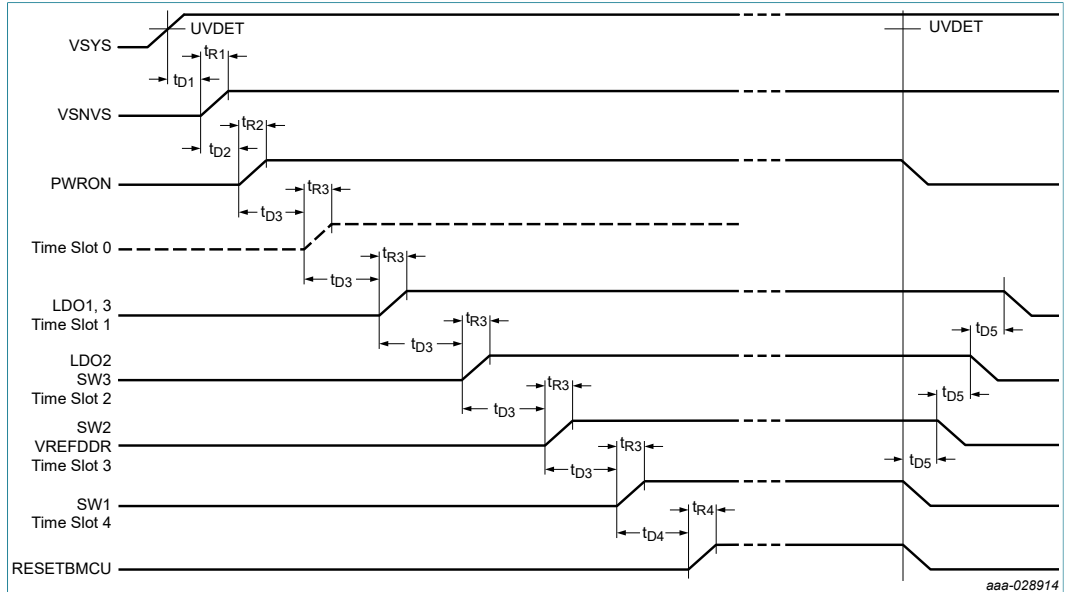

Figure 15. A4 startup and power down sequence

Table 52. A4 startup and power down sequence timing

Parameter	Description ^[1]	Min	Typ	Max	Unit
t _{D1}	Turn-on delay of VSNVS	—	0.6	—	ms
t _{R1}	Rise time of VSNVS	—	0.1	—	ms
t _{D2}	User determined delay	—	—	—	ms
t _{R2}	Rise time of PWRON	—	[2]	—	ms
t _{D3}	Power up delay between regulators • OTP_SEQ_CLK_SPEED = 0 • OTP_SEQ_CLK_SPEED = 1	—	0.5 2.0	—	ms
t _{R3}	Rise time of regulators	—	0.2	—	ms
t _{D4}	Turn-on delay of RESETBMCU	—	2.0	—	ms
t _{R4}	Rise time of RESETBMCU	—	0.2	—	ms
t _{D5}	Power down delay between regulators	—	2.0	—	ms

[1] All regulators avoid drop-out mode at startup
 [2] Depends on the external signal driving PWRON
 [3] A4 configuration
 [4] Rise time is a function of slew rate of regulators and nominal voltage selected.

11.2 Device start up configuration

Table 53. PF1510 start up configuration

Registers	Pre-programmed OTP configuration						
	A1	A2	A3	A4	A5	A6	A7
Default I ² C Address	0x08	0x08	0x08	0x08	0x08	0x08	0x08
OTP_VSNVS_VOLT[2:0]	3.0 V	3.0 V	3.0 V	3.0 V	3.0 V	3.0 V	3.0 V
OTP_SW1_VOLT[5:0]	1.1 V	1.0V	1.3875 V	1.1 V	1.3875 V	1.275 V	1.3875 V

Power management integrated circuit (PMIC) for low power application processors

	Pre-programmed OTP configuration						
Registers	A1	A2	A3	A4	A5	A6	A7
OTP_SW1_PWRUP_SEQ[2:0]	1	5	3	4	3	3	3
OTP_SW2_VOLT[5:0]	1.1 V	1.2V	1.35 V	1.2 V	1.5 V	1.35 V	1.2 V
OTP_SW2_PWRUP_SEQ[2:0]	2	5	3	3	3	3	3
OTP_SW3_VOLT[5:0]	1.8 V	1.8V	3.3 V	1.8 V	3.3 V	3.3 V	1.8 V
OTP_SW3_PWRUP_SEQ[2:0]	3	1	3	2	3	3	3
OTP_LDO1_VOLT[4:0]	1.0 V	1.8 V	1.8 V	3.3 V	1.8 V	1.8 V	3.3 V
OTP_LDO1_PWRUP_SEQ[2:0]	4	1	3	1	3	3	3
OTP_LDO2_VOLT[3:0]	2.5 V	3.3 V	3.3 V	3.3 V	3.3 V	3.3 V	3.3 V
OTP_LDO2_PWRUP_SEQ[2:0]	4	1	2	2	2	2	2
OTP_LDO3_VOLT[4:0]	1.0 V	1.8 V	3.3 V	1.8 V	3.3 V	3.3 V	3.3 V
OTP_LDO3_PWRUP_SEQ[2:0]	5	1	3	1	3	3	3
OTP_VREFDDR_PWRUP_SEQ[2:0]	5	5	3	3	3	3	3
OTP_SW1_DVS_SEL	Non-DVS mode	DVS mode					
OTP_SW2_DVS_SEL	DVS mode	Non-DVS mode	DVS mode	Non-DVS mode			
OTP_LDO1_LS_EN	LDO mode						
OTP_LDO3_LS_EN	LS mode	LDO mode					
OTP_SW1_RDIS_ENB	Enabled						
OTP_SW2_RDIS_ENB	Enabled						
OTP_SW3_RDIS_ENB	Enabled						
OTP_SW1_DVSSPEED	12.5 mV step each 4.0 μ s						
OTP_SW2_DVSSPEED	12.5 mV step each 2.0 μ s	12.5 mV step each 4.0 μ s					
OTP_SWx_EN_AND_STBY_EN	SW1, SW2, SW3 enabled in RUN and STANDBY						
OTP_LDOx_EN_AND_STBY_EN	LDO1, LDO2, LDO3, VREFDDR enabled in RUN and STANDBY						
OTP_PWRON_CFG	Level sensitive						
OTP_SEQ_CLK_SPEED	0.5 ms time slots	2 ms time slots					
OTP_TGRESET[1:0]	4 secs global reset timer						
OTP_POR_DLY[2:0]	2 ms RESETBMCU power-up delay						
OTP_UVDET[1:0]	Rising 3.0 V; falling 2.9 V						
OTP_I2C_DEGLITCH_EN	I ² C deglitch filter disabled						
OTP_VSYSMIN[1:0]	VSYSMIN = 4.3 V					VSYSMIN = 3.7 V	VSYSMIN = 4.3 V
OTP_VIN_ILIM[4:0]	VIN ILIM = 500 mA	VIN ILIM = 1500 mA					

Registers	Pre-programmed OTP configuration						
	A1	A2	A3	A4	A5	A6	A7
OTP_USBPHYLDO	USBPHY LDO disabled	USBPHY LDO enabled					
OTP_USBPHY	USBPHY = 3.3 V						
OTP_ACTDISPHY	USBPHY active discharge disabled	USBPHY active discharge enabled					

12 Register map

12.1 Specific PMIC Registers (Offset is 0x00)

The following pages contain description of the various registers in the PF1510.

Table 54. Register DEVICE_ID - ADDR 0x00

Name	Bit	R/W	Default	Description
DEVICE_ID	2 to 0	R	100	Loaded from fuses 000 — Future use 001 — Future use 010 — Future use 011 — Future use 100 — PF1510 101 — Future use 110 — Future use 111 — Future use
FAMILY	7 to 3	R	01111	Identifies PMIC 01111 — 0b0_1111 for "15" used to denote the "PF1510"

Table 55. Register OTP_FLAVOR - ADDR 0x01

Name	Bit	R/W	Default	Description
UNUSED	7 to 0	R	0x00	Blown by ATE to indicate flavor of OTP used 0x00 — OTP not burned 0x01 — A1 0x02 — A2 0x03 — A3 continues...

Table 56. Register SILICON_REV - ADDR 0x02

Name	Bit	R/W	Default	Description
METAL_LAYER_REV	2 to 0	R	000	Unused
FULL_LAYER_REV	5 to 3	R	001	Unused

Name	Bit	R/W	Default	Description
FAB_FIN	7 to 6	R	00	Unused

Table 57. Register INT_CATEGORY - ADDR 0x06

Name	Bit	R/W	Default	Description
VIN_INT	0	R	0	This bit is set high if the VIN_I interrupt bit is set 0 — No interrupt bit is set, cleared, or did not occur 1 — "OR" function of all interrupt status bit
SW1_INT	1	R	0	This bit is set high if any of the Buck 1 interrupt status bits are set 0 — SW1 interrupts cleared or did not occur 1 — Any of the SW1 interrupt status bits are set
SW2_INT	2	R	0	This bit is set high if any of the Buck 2 interrupt status bits are set 0 — SW2 interrupts cleared or did not occur 1 — Any of the SW2 interrupt status bits are set
SW3_INT	3	R	0	This bit is set high if any of the Buck 3 interrupt status bits are set 0 — SW3 interrupts cleared or did not occur 1 — any of the SW3 interrupt status bits are set
LDO_INT	4	R	0	This bit is set high if any of the LDO interrupt status bits are set. This includes LDO1, LDO2 and LDO3. 0 — LDO interrupts cleared or did not occur 1 — Any of the LDO interrupt status bits are set
ONKEY_INT	5	R	0	This bit is set high if any of the interrupts associated with ONKEY push button are set. 0 — ONKEY related interrupts cleared or did not occur 1 — Any of the ONKEY interrupt status bits are set
TEMP_INT	6	R	0	This bit is set if any of the interrupts associated with the die temperature monitor are set 0 — PMIC junction temperature related interrupts cleared or did not occur 1 — any of the PMIC junction temperature interrupts status bits are set
MISC_INT	7	R	0	This bit is set if interrupts not covered by the above mentioned categories occur 0 — Other interrupts (not covered by categories above) cleared, or did not occur 1 — Status bit of other interrupts (not covered by categories above) is set

Table 58. Register SW_INT_STAT0 - ADDR 0x08

Name	Bit	R/W	Default	Description
SW1_LS_I	0	RW1C ^[1]	0	SW1 low-side current limit interrupt status. This bit is set if the current limit fault persists for longer than the debounce time. 0 — Interrupt cleared or did not occur 1 — Interrupt occurred and/or not cleared

Power management integrated circuit (PMIC) for low power application processors

Name	Bit	R/W	Default	Description
SW2_LS_I	1	RW1C	0	SW2 low-side current limit interrupt status. This bit is set if the current limit fault persists for longer than the debounce time. 0 — Interrupt cleared or did not occur 1 — Interrupt occurred and/or not cleared
SW3_LS_I	2	RW1C	0	SW3 low-side current limit interrupt status. This bit is set if the current limit fault persists for longer than the debounce time. 0 — Interrupt cleared or did not occur 1 — Interrupt occurred and/or not cleared
UNUSED	7 to 3	—	—	Unused

[1] Read or Write 1 to clear the bit

Table 59. Register SW_INT_MASK0 - ADDR 0x09

Name	Bit	R/W	Default	Description
SW1_LS_M	0	RW	1	SW1 low-side current limit interrupt mask 0 — Mask removed. INTB pin is pulled low if corresponding interrupt status bit is set. 1 — Mask enabled. INTB pin is NOT pulled low if corresponding interrupt status bit is set.
SW2_LS_M	1	RW	1	SW2 low-side current limit interrupt mask 0 — Mask removed. INTB pin is pulled low if corresponding interrupt status bit is set. 1 — Mask enabled. INTB pin is NOT pulled low if corresponding interrupt status bit is set.
SW3_LS_M	2	RW	1	SW3 low-side current limit interrupt mask 0 — Mask removed. INTB pin is pulled low if corresponding interrupt status bit is set. 1 — Mask enabled. INTB pin is NOT pulled low if corresponding interrupt status bit is set.
UNUSED	7 to 3	—	—	Unused

Table 60. Register SW_INT_SENSE0 - ADDR 0x0A

Name	Bit	R/W	Default	Description
SW1_LS_S	0	R	0	SW1 low-side current limit interrupt sense. Sense is high as long as fault persists (post-debounce). 0 — Fault removed 1 — Fault exists
SW2_LS_S	1	R	0	SW2 low-side current limit interrupt sense. Sense is high as long as fault persists (post-debounce). 0 — Fault removed 1 — Fault exists
SW3_LS_S	2	R	0	SW3 low-side current limit interrupt sense. Sense is high as long as fault persists (post-debounce). 0 — Fault removed 1 — Fault exists

Power management integrated circuit (PMIC) for low power application processors

Name	Bit	R/W	Default	Description
UNUSED	7 to 3	—	—	Unused

Table 61. Register SW_INT_STAT1 - ADDR 0x0B

Name	Bit	R/W	Default	Description
SW1_HS_I	0	RW1C ^[1]	0	SW1 high-side current limit interrupt 0 — Interrupt cleared or did not occur 1 — Interrupt occurred and/or not cleared
SW2_HS_I	1	RW1C	0	SW2 high-side current limit interrupt 0 — Interrupt cleared or did not occur 1 — Interrupt occurred and/or not cleared
SW3_HS_I	2	RW1C	0	SW3 high-side current limit interrupt 0 — Interrupt cleared or did not occur 1 — Interrupt occurred and/or not cleared
UNUSED	7 to 3	—	—	Unused

[1] Read or Write 1 to clear the bit

Table 62. Register SW_INT_MASK1 - ADDR 0x0C

Name	Bit	R/W	Default	Description
SW1_HS_M	0	RW	1	SW1 high-side current limit interrupt mask 0 — Mask removed. INTB pin is pulled low if corresponding interrupt status bit is set. 1 — Mask enabled. INTB pin is NOT pulled low if corresponding interrupt status bit is set.
SW2_HS_M	1	RW	1	SW2 high-side current limit interrupt mask 0 — Mask removed. INTB pin is pulled low if corresponding interrupt status bit is set. 1 — Mask enabled. INTB pin is NOT pulled low if corresponding interrupt status bit is set.
SW3_HS_M	2	RW	1	SW3 high-side current limit interrupt mask 0 — Mask removed. INTB pin is pulled low if corresponding interrupt status bit is set. 1 — Mask enabled. INTB pin is NOT pulled low if corresponding interrupt status bit is set.
UNUSED	7 to 3	—	—	Unused

Table 63. Register SW_INT_SENSE1 - ADDR 0x0D

Name	Bit	R/W	Default	Description
SW1_HS_S	0	R	0	SW1 high-side current limit interrupt sense. This bit should not toggle within a switching cycle (at buck switching frequency), but report the sense status within the switching cycle. 0 — Fault removed 1 — Fault exists

Power management integrated circuit (PMIC) for low power application processors

Name	Bit	R/W	Default	Description
SW2_HS_S	1	R	0	SW2 high-side current limit interrupt sense. This bit should not toggle within a switching cycle (at buck switching frequency), but report the sense status within the switching cycle. 0 — Fault removed 1 — Fault exists
SW3_HS_S	2	R	0	SW3 high-side current limit interrupt sense. This bit should not toggle within a switching cycle (at buck switching frequency), but report the sense status within the switching cycle. 0 — Fault removed 1 — Fault exists
UNUSED	7 to 3	—	—	Unused

Table 64. Register SW_INT_STAT2 - ADDR 0x0E

Name	Bit	R/W	Default	Description
SW1_DVS_DONE_I	0	RW1C ^[1]	0	Interrupt to indicate SW1 DVS complete. This interrupt should occur every time regulator output voltage is changed (either via I ² C within a given state, or if there is change in voltage when transitioning states, Run to Standby, for example). 0 — DVS not complete and/or bit cleared 1 — DVS complete
SW2_DVS_DONE_I	1	RW1C	0	Interrupt to indicate SW2 DVS complete. This interrupt should occur every time regulator output voltage is changed (either via I ² C within a given state, or if there is change in voltage when transitioning states, Run to Standby, for example). 0 — DVS not complete and/or bit cleared 1 — DVS complete
UNUSED	7 to 2	—	—	Unused

[1] Read or Write 1 to clear the bit

Table 65. Register SW_INT_MASK2 - ADDR 0x0F

Name	Bit	R/W	Default	Description
SW1_DVS_DONE_M	0	RW	1	Mask for interrupt that indicates SW1 DVS complete 0 — Mask removed. INTB pin is pulled low if corresponding interrupt status bit is set. 1 — Mask enabled. INTB pin is not pulled low if corresponding interrupt status bit is set.
SW2_DVS_DONE_M	1	RW	1	Mask for interrupt that indicates SW2 DVS complete 0 — Mask removed. INTB pin is pulled low if corresponding interrupt status bit is set. 1 — Mask enabled. INTB pin is not pulled low if corresponding interrupt status bit is set.
UNUSED	7 to 2	—	—	Unused

Table 66. Register SW_INT_SENSE2 - ADDR 0x10

Name	Bit	R/W	Default	Description
SW1_DVS_S	0	R	0	Indicates DVS in progress for SW1 0 — DVS not in progress 1 — DVS in progress
SW2_DVS_S	1	R	0	Indicates DVS in progress for SW2 0 — DVS not in progress 1 — DVS in progress
UNUSED	7 to 2	—	—	Unused

Table 67. Register LDO_INT_STAT0 - ADDR 0x18

Name	Bit	R/W	Default	Description
LDO1_FAULTI	0	RW1C ^[1]	0	LDO1 current limit interrupt 0 — Interrupt cleared or did not occur 1 — Interrupt occurred and/or not cleared
LDO2_FAULTI	1	RW1C	0	LDO2 current limit interrupt 0 — Interrupt cleared or did not occur 1 — Interrupt occurred and/or not cleared
LDO3_FAULTI	2	RW1C	0	LDO3 current limit interrupt 0 — Interrupt cleared or did not occur 1 — Interrupt occurred and/or not cleared
UNUSED	7 to 3	—	—	Unused

[1] Read or Write 1 to clear the bit

Table 68. Register LDO_INT_MASK0 - ADDR 0x19

Name	Bit	R/W	Default	Description
LDO1_FAULTM	0	RW	1	LDO1 current limit fault interrupt mask 0 — Mask removed. INTB pin is pulled low if corresponding interrupt status bit is set. 1 — Mask enabled. INTB pin is not pulled low if corresponding interrupt status bit is set.
LDO2_FAULTM	1	RW	1	LDO2 current limit fault interrupt mask 0 — Mask removed. INTB pin is pulled low if corresponding interrupt status bit is set 1 — Mask enabled. INTB pin is not pulled low if corresponding interrupt status bit is set.
LDO3_FAULTM	2	RW	1	LDO3 current limit fault interrupt mask 0 — Mask removed. INTB pin is pulled low if corresponding interrupt status bit is set. 1 — Mask enabled. INTB pin is not pulled low if corresponding interrupt status bit is set.
UNUSED	7 to 3	—	—	Unused

Table 69. Register LDO_INT_SENSE0 - ADDR 0x1A

Name	Bit	R/W	Default	Description
LDO1_FAULTS	0	R	0	LDO1 fault interrupt sense 0 — Fault removed 1 — Fault exists
LDO2_FAULTS	1	R	0	LDO2 fault interrupt sense 0 — Fault removed 1 — Fault exists
LDO3_FAULTS	2	R	0	LDO3 fault interrupt sense 0 — Fault removed 1 — Fault exists
UNUSED	7 to 3	—	—	Unused

Table 70. Register TEMP_INT_STAT0 - ADDR 0x20

Name	Bit	R/W	Default	Description
THERM110I	0	RW1C ^[1]	0	Die temperature crosses 110 °C interrupt. Bidirectional interrupt. 0 — Interrupt cleared or did not occur 1 — Interrupt occurred and/or not cleared
UNUSED	1	—	—	Unused
THERM125I	2	RW1C	0	Die temperature crosses 125 °C interrupt. Bidirectional interrupt. 0 — Interrupt cleared or did not occur 1 — Interrupt occurred and/or not cleared
UNUSED	7 to 3	—	—	Unused

[1] Read or Write 1 to clear the bit

Table 71. Register TEMP_INT_MASK0 - ADDR 0x21

Name	Bit	R/W	Default	Description
THERM110M	0	RW	1	Die temperature crosses 110 °C interrupt mask 0 — Mask removed. INTB pin is pulled low if corresponding interrupt status bit is set. 1 — Mask enabled. INTB pin is NOT pulled low if corresponding interrupt status bit is set.
UNUSED	1	—	—	Unused
THERM125M	2	RW	1	Die temperature crosses 125 °C interrupt mask 0 — Mask removed. INTB pin is pulled low if corresponding interrupt status bit is set. 1 — Mask enabled. INTB pin is not pulled low if corresponding interrupt status bit is set.
UNUSED	7 to 3	—	—	Unused

Table 72. Register TEMP_INT_SENSE0 - ADDR 0x22

Name	Bit	R/W	Default	Description
THERM110S	0	R	0	110 °C interrupt sense 0 — Die temperature below 110 °C 1 — Die temperature above 110 °C
UNUSED	1	—	—	Unused
THERM125S	2	R	0	125 °C interrupt sense 0 — Die temperature below 125 °C 1 — Die temperature above 125 °C
UNUSED	7 to 3	—	—	Unused

Table 73. Register ONKEY_INT_STAT0 - ADDR 0x24

Name	Bit	R/W	Default	Description
ONKEY_PUSHI	0	RW1C ^[1]	0	Interrupt to indicate a push of the ONKEY button. Goes high after debounce. 0 — Interrupt cleared or did not occur 1 — Interrupt occurred and/or not cleared. Interrupt occurs whenever ONKEY button is pushed low for longer than the falling edge debounce setting. Interrupt also occurs whenever ONKEY button is released high for longer than the rising edge debounce setting, provided it went past the falling edge debounce time. In other words, this interrupt occurs whenever a change in status of the ONKEY_PUSHHS sense bit occurs.
ONKEY_1SI	1	RW1C	0	Interrupt after ONKEY pressed for > 1 s 0 — Interrupt cleared or did not occur 1 — Interrupt occurred and/or not cleared
ONKEY_2SI	2	RW1C	0	Interrupt after ONKEY pressed for > 2 s 0 — Interrupt cleared or did not occur 1 — Interrupt occurred and/or not cleared
ONKEY_3SI	3	RW1C	0	Interrupt after ONKEY pressed for > 3 s 0 — Interrupt cleared or did not occur 1 — Interrupt occurred and/or not cleared
ONKEY_4SI	4	RW1C	0	Interrupt after ONKEY pressed for > 4 s 0 — Interrupt cleared or did not occur 1 — Interrupt occurred and/or not cleared
ONKEY_8SI	5	RW1C	0	Interrupt after ONKEY pressed for > 8 s 0 — Interrupt cleared or did not occur 1 — Interrupt occurred and/or not cleared
UNUSED	7 to 6	—	—	Unused

[1] Read or Write 1 to clear the bit

Table 74. Register ONKEY_INT_MASK0 - ADDR 0x25

Name	Bit	R/W	Default	Description
ONKEY_PUSHM	0	RW	1	Interrupt mask for ONKEY_PUSH_I 0 — Mask removed. INTB pin is pulled low if corresponding interrupt status bit is set. 1 — Mask enabled. INTB pin is not pulled low if corresponding interrupt status bit is set.
ONKEY_1SM	1	RW	1	Interrupt mask for ONKEY_1SI 0 — Mask removed. INTB pin is pulled low if corresponding interrupt status bit is set. 1 — Mask enabled. INTB pin is not pulled low if corresponding interrupt status bit is set.
ONKEY_2SM	2	RW	1	Interrupt mask for ONKEY_2SI 0 — Mask removed. INTB pin is pulled low if corresponding interrupt status bit is set. 1 — Mask enabled. INTB pin is NOT pulled low if corresponding interrupt status bit is set.
ONKEY_3SM	3	RW	1	Interrupt mask for ONKEY_3SI 0 — Mask removed. INTB pin is pulled low if corresponding interrupt status bit is set. 1 — Mask enabled. INTB pin is not pulled low if corresponding interrupt status bit is set.
ONKEY_4SM	4	RW	1	Interrupt mask for ONKEY_4SI 0 — Mask removed. INTB pin is pulled low if corresponding interrupt status bit is set. 1 — Mask enabled. INTB pin is not pulled low if corresponding interrupt status bit is set.
ONKEY_8SM	5	RW	1	Interrupt mask for ONKEY_8SI 0 — Mask removed. INTB pin is pulled low if corresponding interrupt status bit is set. 1 — Mask enabled. INTB pin is not pulled low if corresponding interrupt status bit is set.
UNUSED	7 to 6	—	—	Unused

Table 75. Register ONKEY_INT_SENSE0 - ADDR 0x26

Name	Bit	R/W	Default	Description
ONKEY_PUSHS	0	R	0	Push interrupt sense 0 — ONKEY not pushed low. This bit follows debounced version of the ONKEY button being released. 1 — ONKEY pushed low. This follows the ONKEY button after the debounce circuit (debounce is programmable).
ONKEY_1SS	1	R	0	1 s interrupt sense or cleared after ONKEY button is released 0 — ONKEY not pushed low for >1 s or cleared after ONKEY button is released. 1 — ONKEY pushed and being held low > 1 s. This bit is cleared when ONKEY_PUSHS goes back to 0 when the push button is released.

Power management integrated circuit (PMIC) for low power application processors

Name	Bit	R/W	Default	Description
ONKEY_2SS	2	R	0	2 s interrupt sense or cleared after ONKEY button is released 0 — ONKEY not pushed low for >1 s or cleared after ONKEY button is released. 1 — ONKEY pushed and being held low > 1 s. This bit is cleared when ONKEY_PUSHES goes back to 0 when the push button is released.
ONKEY_3SS	3	R	0	3 s interrupt sense or cleared after ONKEY button is released 0 — ONKEY not pushed low for >1 s or cleared after ONKEY button is released 1 — ONKEY pushed and being held low > 1 s. This bit is cleared when ONKEY_PUSHES goes back to 0 when the push button is released.
ONKEY_4SS	4	R	0	4 s interrupt sense or cleared after ONKEY button is released 0 — ONKEY not pushed low for >1 s or cleared after ONKEY button is released. 1 — ONKEY pushed and being held low > 1 s. This bit is cleared when ONKEY_PUSHES goes back to 0 when the push button is released.
ONKEY_8SS	5	R	0	8 s interrupt sense or cleared after ONKEY button is released 0 — ONKEY not pushed low for >1 s or cleared after ONKEY button is released. 1 — ONKEY pushed and being held low > 1 s. This bit is cleared when ONKEY_PUSHES goes back to 0 when the push button is released.
UNUSED	7 to 6	—	—	Unused

Table 76. Register MISC_INT_STAT0 - ADDR 0x28

Name	Bit	R/W	Default	Description
PWRUP_I	0	RW1C ⁽¹⁾	0	Interrupt to indicate completion of transition from STANDBY to RUN and from SLEEP to RUN 0 — Interrupt cleared or has not occurred 1 — Interrupt has occurred
PWRDN_I	1	RW1C	0	Interrupt to indicate completion of transition from RUN to STANDBY and from RUN to SLEEP 0 — Interrupt cleared or has not occurred 1 — Interrupt has occurred
PWRON_I	2	RW1C	0	Power on button event interrupt 0 — Interrupt cleared or has not occurred 1 — Interrupt has occurred
LOW_SYS_WARN_I	3	RW1C	0	LOW_SYS_WARN threshold crossed interrupt 0 — Interrupt cleared or has not occurred 1 — Interrupt has occurred
SYS_OVLO_I	4	RW1C	0	SYS_OVLO threshold crossed interrupt 0 — Interrupt cleared or has not occurred 1 — Interrupt has occurred
UNUSED	7 to 5	—	—	Unused

[1] Read or Write 1 to clear the bit

Table 77. Register MISC_INT_MASK0- ADDR 0x29

Name	Bit	R/W	Default	Description
PWRUP_M	0	RW ^[1]	1	Mask for interrupt to indicate completion on transition from STANDBY to RUN and from SLEEP to RUN 0 — Mask removed. INTB pin is pulled low if corresponding interrupt status bit is set. 1 — Mask enabled. INTB pin is not pulled low if corresponding interrupt status bit is set.
PWRDN_M	1	RW	1	Mask for interrupt to indicate completion on transition from RUN to STANDBY and from RUN to SLEEP 0 — Mask removed. INTB pin is pulled low if corresponding interrupt status bit is set. 1 — Mask enabled. INTB pin is not pulled low if corresponding interrupt status bit is set.
PWRON_M	2	RW	1	Power on button event interrupt mask 0 — Mask removed. INTB pin is pulled low if corresponding interrupt status bit is set. 1 — Mask enabled. INTB pin is not pulled low if corresponding interrupt status bit is set.
LOW_SYS_WARN_M	3	RW	1	LOW_SYS_WARN threshold crossed interrupt mask 0 — Mask removed. INTB pin is pulled low if corresponding interrupt status bit is set. 1 — Mask enabled. INTB pin is not pulled low if corresponding interrupt status bit is set.
SYS_OVLO_M	4	RW	1	SYS_OVLO threshold crossed interrupt mask 0 — Mask removed. INTB pin is pulled low if corresponding interrupt status bit is set. 1 — Mask enabled. INTB pin is not pulled low if corresponding interrupt status bit is set.
UNUSED	7 to 5	—	—	Unused

[1] Asynchronous Set, Read and Write

Table 78. Register MISC_INT_SENSE0 - ADDR 0x2A

Name	Bit	R/W	Default	Description
PWRUP_S	0	R	0	Sense for interrupt to indicate completion on transition from STANDBY to RUN and from SLEEP to RUN 0 — Transition not in progress 1 — Transition in progress
PWRDN_S	1	R	0	Interrupt to indicate completion on transition from RUN to STANDBY and from RUN to SLEEP 0 — Transition not in progress 1 — Transition in progress

Power management integrated circuit (PMIC) for low power application processors

Name	Bit	R/W	Default	Description
PWRON_S	2	R	0	Power on button event interrupt sense 0 — PWRON low 1 — PWRON high
LOW_SYS_WARN_S	3	R	0	LOW_SYS_WARN threshold crossed interrupt sense 0 — SYS > LOW_SYS_WARN 1 — SYS < LOW_SYS_WARN
SYS_OVLO_S	4	R	0	SYS_OVLO threshold crossed interrupt sense 0 — SYS < SYS_OVLO 1 — SYS > SYS_OVLO
UNUSED	7 to 5	—	—	Unused

Table 79. Register COINCELL_CONTROL - ADDR 0x30

Name	Bit	R/W	Default	Description
VCOIN	3 to 0	RW	0000	Coin cell charger charging voltage 0000 — 1.8 V 0111 — 3.3 V (goes up in 100 mV step per LSB)
COINCHEN	4	RW	0	Coin cell charger enable 0 — Charger disabled 1 — Charger enabled
UNUSED	7 to 5	—	—	Unused

Table 80. Register SW1_VOLT - ADDR 0x32

Name	Bit	R/W	Default	Description
SW1_VOLT	5 to 0	RW1S ^[1]	—	SW1 voltage setting register (Run mode) 000000 — See Table 23 for voltage settings 111111 — See Table 23 for voltage settings Reset condition — POR
UNUSED	7 to 5	—	—	Unused

[1] Load from OTP fuse, Read and Write

Table 81. Register SW1_STBY_VOLT - ADDR 0x33

Name	Bit	R/W	Default	Description
SW1_STBY_VOLT	5 to 0	RW1S ^[1]	—	SW1 output voltage setting register (Standby mode). The default value here should be identical to SW1_VOLT[5:0] register. 000000 — See Table 23 for voltage settings 111111 — See Table 23 for voltage settings
UNUSED	7 to 6	—	—	Unused

[1] Load from OTP fuse, Read and Write

Table 82. Register SW1_SLP_VOLT - ADDR 0x34

Name	Bit	R/W	Default	Description
SW1_SLP_VOLT	5 to 0	RW1S ^[1]	—	SW1 output voltage setting register (Sleep mode). The default value here should be identical to SW1_VOLT[5:0] register. 000000 — See Table 23 for voltage settings 111111 — See Table 23 for voltage settings
UNUSED	7 to 6	—	—	Unused

[1] Load from OTP fuse, Read and Write

Table 83. Register SW1_CTRL - ADDR 0x35

Name	Bit	R/W	Default	Description
SW1_EN	0	RW1S ^[1]	0	Enables buck regulator. Loaded from OTP based on the sequence settings. User can turn regulator off by clearing this bit. 0 — Regulator disabled in Run mode 1 — Regulator enabled in Run mode
SW1_STBY_EN	1	RW1S	0	Enables buck regulator in Standby mode. User can turn regulator off by clearing this bit. The default value of this bit should be equal to the SW1_EN bit (based on OTP). 0 — Regulator disabled in Standby mode 1 — Regulator enabled in Standby mode
SW1_OMODE	2	RW ^[2]	0	Enables buck regulator in Sleep mode. User can turn regulator off by clearing this bit. 0 — Regulator disabled in Sleep mode 1 — Regulator enabled in Sleep mode
SW1_LPWR	3	RW	0	Enables the buck to enter Low-power mode during Standby and Sleep 0 — Regulator not in Low-power mode 1 — Regulator in Low-power mode during Standby or Sleep modes
SW1_DVSSPEED	4	RW1S	0	Controls slew rate of DVS transitions. Loaded from OTP and changeable by user after boot up. Not used when OTP_SW1_DVS_SEL = 1. 0 — DVS rate at 12.5 mV/2 μ s 1 — DVS rate at 12.5 mV/4 μ s
SW1_FPWM_IN_DVS	5	RW	0	Enables CCM operation during DVS down 0 — does not force FPWM during DVS 1 — forces regulator to track the DVS reference while it is falling rather than relying on the load current to pull the voltage low
SW1_FPWM	6	RW	0	Forces buck to go into CCM mode 0 — Not in FPWM mode 1 — Forced in PWM mode irrespective of load current

Power management integrated circuit (PMIC) for low power application processors

Name	Bit	R/W	Default	Description
SW1_RDIS_ENB	7	RW1S	0	Controls discharge resistor on output when regulator disabled 0 — Enables discharge resistor on output when regulator disabled. Resistor connected at FB pin when regulator disabled to force capacitor discharge. 1 — Disables discharge resistor on output when regulator disabled. Resistor not connected at FB pin when regulator disabled. Relies on leakage/residue load to discharge output capacitor.

[1] Load from OTP fuse, Read and Write

[2] Asynchronous Set, Read and Write

Table 84. Register SW1_SLP_VOLT - ADDR 0x36

Name	Bit	R/W	Default	Description
SW1_ILIM	1 to 0	RW1S ^[1]	00	Sets current limit of SW1 regulator 00 — Typical current limit of 1.0 A 01 — Typical current limit of 1.2 A 10 — Typical current limit of 1.5 A 11 — Typical current limit of 2.0 A
UNUSED	3 to 2	—	—	Unused
SW1_TMODE_SEL	4	RW	0	0 — TON control 1 — TOFF control
UNUSED	7 to 5	—	—	Unused

[1] Load from OTP fuse, Read and Write

Table 85. Register SW2_VOLT - ADDR 0x38

Name	Bit	R/W	Default	Description
SW2_VOLT	5 to 0	RW1S ^[1]	—	SW2 voltage setting register (Run mode) 000000 — See Table 23 for voltage settings 111111 — See Table 23 for voltage settings
UNUSED	7 to 6	—	—	Unused

[1] Load from OTP fuse, Read and Write

Table 86. Register SW2_STBY_VOLT - ADDR 0x39

Name	Bit	R/W	Default	Description
SW2_STBY_VOLT	5 to 0	RW1S ^[1]	—	SW2 output voltage setting register (Standby mode). The default value here should be identical to SW2_VOLT[5:0] register. 000000 — See Table 23 for voltage settings 111111 — See Table 23 for voltage settings
UNUSED	7 to 6	—	—	Unused

[1] Load from OTP fuse, Read and Write

Table 87. Register SW2_SLP_VOLT - ADDR 0x3A

Name	Bit	R/W	Default	Description
SW2_SLP_VOLT	5 to 0	RW1S ^[1]	—	SW2 output voltage setting register (Sleep mode). The default value here should be identical to SW2_VOLT[5:0] register. 000000 — See Table 23 for voltage settings 111111 — See Table 23 for voltage settings
UNUSED	7 to 6	—	—	Unused

[1] Load from OTP fuse, Read and Write

Table 88. Register SW2_CTRL - ADDR 0x3B

Name	Bit	R/W	Default	Description
SW2_EN	0	RW1S ^[1]	0	Enables buck regulator. Loaded from OTP based on the sequence settings. User can turn regulator off by clearing this bit. 0 — Regulator disabled in Run mode 1 — Regulator enabled in Run mode
SW2_STBY_EN	1	RW1S	0	Enables buck regulator in Standby mode. User can turn regulator off by clearing this bit. The default value of this bit should be equal to the SW1_EN bit (based on OTP). 0 — Regulator disabled in Standby mode 1 — Regulator enabled in Standby mode
SW2_OMODE	2	RW	0	Enables buck regulator in Sleep mode. User can turn regulator off by clearing this bit. 0 — Regulator disabled in Sleep mode 1 — Regulator enabled in Sleep mode
SW2_LPWR	3	RW	0	Enables the buck to enter Low-power mode during Standby and Sleep modes 0 — Regulator not in Low-power mode 1 — Regulator in Low-power mode during Standby or Sleep
SW2_DVSSPEED	4	RW1S	0	Controls slew rate of DVS transitions. Loaded from OTP and changeable by user after boot up. Not used when OTP_SW2_DVS_SEL = 1. 0 — DVS rate at 12.5 mV/2 μ s 1 — DVS rate at 12.5 mV/4 μ s
SW2_FPWM_IN_DVS	5	RW	0	Enables CCM operation during DVS down 0 — does not force FPWM during DVS 1 — forces regulator to track the DVS reference while it is falling rather than relying on the load current to pull the voltage low
SW2_FPWM	6	RW	0	Forces buck to go into CCM mode 0 — Not in FPWM mode 1 — Forced in PWM mode irrespective of load current.

Power management integrated circuit (PMIC) for low power application processors

Name	Bit	R/W	Default	Description
SW2_RDIS_ENB	7	RW1S	0	Controls discharge resistor on output when regulator disabled 0 — Enables discharge resistor on output when regulator disabled. Resistor connected at FB pin when regulator disabled to force capacitor discharge. 1 — Disables discharge resistor on output when regulator disabled. Resistor not connected at FB pin when regulator disabled. Relies on leakage/residue load to discharge output capacitor.

[1] Load from OTP fuse, Read and Write

Table 89. Register SW2_CTRL1 - ADDR 0x3C

Name	Bit	R/W	Default	Description
SW2_ILIM	1 to 0	RW1S	00	Sets current limit of SW2 regulator 00 — Typical current limit of 1.0 A 01 — Typical current limit of 1.2 A 10 — Typical current limit of 1.5 A 11 — Typical current limit of 2.0 A
UNUSED	3 to 2	—	—	Unused
SW2_TMODE_SEL	4	RW	0	0 — TON control 1 — TOFF control
UNUSED	7 to 5	—	—	Unused

Table 90. Register SW3_VOLT - ADDR 0x3E

Name	Bit	R/W	Default	Description
SW3_VOLT	3 to 0	RW1S	—	SW3 voltage setting register (Run mode). Loaded from fuses. Read only because DVS is not supported in this regulator. 0000 — See Table 29 for voltage settings 1111 — See Table 29 for voltage settings
UNUSED	7 to 4	—	—	Unused

Table 91. Register SW3_STBY_VOLT - ADDR 0x3F

Name	Bit	R/W	Default	Description
SW3_STBY_VOLT	3 to 0	RW1S	—	SW3 voltage setting register (Standby mode). Loaded from fuses. Read only because DVS is not supported in this regulator. 0000 — See Table 29 for voltage settings 1111 — See Table 29 for voltage settings
UNUSED	7 to 4	—	—	Unused

Table 92. Register SW3_SLP_VOLT - ADDR 0x40

Name	Bit	R/W	Default	Description
SW3_SLP_VOLT	3 to 0	RW1S	—	SW3 voltage setting register (Sleep mode). Loaded from fuses. Read only because DVS is not supported in this regulator. 0000 — See Table 29 for voltage settings 1111 — See Table 29 for voltage settings
UNUSED	7 to 4	—	—	Unused

Table 93. Register SW3_CTRL - ADDR 0x41

Name	Bit	R/W	Default	Description
SW3_EN	0	RW1S	0	Enables buck regulator. Loaded from OTP based on the sequence settings. User can turn regulator off by clearing this bit. 0 — Regulator disabled in Run mode 1 — Regulator enabled in Run mode
SW3_STBY_EN	1	RW1S	0	Enables buck regulator in Standby mode. User can turn regulator off by clearing this bit. The default value of this bit should be equal to the SW1_EN bit (based on OTP). 0 — Regulator disabled in Standby mode 1 — Regulator enabled in Standby mode
SW3_OMODE	2	RW	0	Enables buck regulator in Sleep mode. User can turn regulator off by clearing this bit. 0 — Regulator disabled in Sleep mode 1 — Regulator enabled in Sleep mode
SW3_LPWR	3	RW	0	Enables the buck to enter Low-power mode during Standby and Sleep modes 0 — Regulator not in Low-power mode 1 — Regulator in Low-power mode while in Standby or Sleep
UNUSED	4	—	—	Unused
UNUSED	5	—	—	Unused
SW3_FPWM	6	RW	0	Forces buck to go into CCM mode 0 — Not in FPWM mode 1 — Forced in PWM mode irrespective of load current
SW3_RDIS_ENB	7	RW1S	0	Controls discharge resistor on output when regulator is disabled 0 — Enables discharge resistor on output when regulator disabled. Resistor connected at FB pin when regulator disabled to force capacitor discharge. 1 — Disables discharge resistor on output when regulator disabled. Resistor not connected at FB pin when regulator disabled. Relies on leakage/residue load to discharge output capacitor.

Table 94. Register SW3_CTRL1 - ADDR 0x42

Name	Bit	R/W	Default	Description
SW3_ILIM	1 to 0	RW1S	00	Sets current limit of SW3 regulator 00 — Typical current limit of 1.0 A 01 — Typical current limit of 1.2 A 10 — Typical current limit of 1.5 A 11 — Typical current limit of 2.0 A
UNUSED	3 to 2	—	—	Unused
SW3_TMODE_SEL	4	RW	0	0 — TON control 1 — TOFF control
UNUSED	7 to 5	—	—	Unused

Table 95. Register VSNVS_CTRL - ADDR 0x48

Name	Bit	R/W	Default	Description
VSNVS_VOLT	2 to 0	RW1S	000	Not used in PF1510. Placeholder for future products.
CLKPULSE	3	RW	0	Optional bit used for evaluation. Refer to IP block
FORCEBOS	4	RW	0	Optional bit for evaluation 0 — BOS circuit activated only when VSYS < UVDET 1 — Forces best of supply circuit irrespective of UVDET
LIBGDIS	5	RW	0	Use to reduce quiescent current in coin cell mode 0 — VSNVS local bandgap enabled in coin cell mode 1 — VSNVS local bandgap disabled in coin cell mode to save quiescent current
UNUSED	7 to 6	—	—	Unused

Table 96. Register VREFDDR_CTRL - ADDR 0x4A

Name	Bit	R/W	Default	Description
VREFDDR_EN	0	RW1S	0	0 — Disables VREFDDR regulator 1 — Enables VREFDDR regulator. This is set by the OTP sequence.
VREFDDR_STBY_EN	1	RW1S	0	The default value for this should be same as VREFDDREN 0 — Disables VREFDDR regulator in Standby mode 1 — Enables VREFDDR regulator in Standby mode if VREFDDREN = 1
VREFDDR_OMODE	2	RW	0	0 — Keeps VREFDDR off in Off mode 1 — Enables VREFDDR in Sleep mode if VREFDDREN = 1
VREFDDR_LPWR	3	RW	0	0 — Disables VREFDDR Low-power mode 1 — Enables VREFDDR Low-power mode
UNUSED	7 to 4	—	—	Unused

Table 97. Register LDO1_VOLT - ADDR 0x4C

Name	Bit	R/W	Default	Description
LDO1_VOLT	4 to 0	RW1S	—	LDO1 output voltage setting register. Loaded from OTP. 00000 — See Table 33 for voltage settings 11111 — See Table 33 for voltage settings
UNUSED	7 to 5	—	—	Unused

Table 98. Register LDO1_CTRL - ADDR 0x4D

Name	Bit	R/W	Default	Description
VLDO1_EN	0	RW1S	0	Enables LDO regulator. Loaded from OTP based on the sequence settings. User can turn regulator off by clearing this bit. 0 — Disables regulator 1 — Enables regulator
VLDO1_STBY_EN	1	RW1S	0	Enables LDO in Standby mode. Default value of this bit should be same as VLDO1_EN. 0 — Disables regulator 1 — Enables regulator
VLDO1_OMODE	2	RW	0	Enables LDO in Sleep mode 0 — Disables regulator 1 — Enables regulator
VLDO1_LPWR	3	RW	0	Forces LDO to Low-power mode in Sleep and Standby modes 0 — Not in Low-power mode during Standby and Sleep 1 — Regulator in Low-power mode during Standby and Sleep
LDO1_LS_EN	4	RW1S	0	This is loaded from OTP_LDOy_LS_EN and changeable from 0 to 1 on power up. Changing from 1 to 0 is not allowed. 0 — Sets LDOy in LDO mode 1 — Sets LDOy to a load switch (fully on) mode
UNUSED	7 to 5	—	—	Unused

Table 99. Register LDO2_VOLT - ADDR 0x4F

Name	Bit	R/W	Default	Description
LDO2_VOLT	3 to 0	RW1S	—	LDO2 output voltage setting register. Loaded from OTP. 0000 — See Table 35 for voltage settings 1111 — See Table 35 for voltage settings
UNUSED	7 to 4	—	—	Unused

Table 100. Register LDO2_CTRL - ADDR 0x50

Name	Bit	R/W	Default	Description
VLDO2_EN	0	RW1S	0	Enables LDO regulator. Loaded from OTP based on the sequence settings. User can turn regulator off by clearing this bit. 0 — Disables regulator 1 — Enables regulator

Power management integrated circuit (PMIC) for low power application processors

Name	Bit	R/W	Default	Description
VLDO2_STBY_EN	1	RW1S	0	Enables LDO in Standby mode. Default value of this bit should be same as VLDO1_EN. 0 — Disables regulator 1 — Enables regulator
VLDO2_OMODE	2	RW	0	Enables LDO in Sleep mode 0 — Disables regulator 1 — Enables regulator
VLDO2_LPWR	3	RW	0	Forces LDO to Low-power mode in Sleep and Standby modes 0 — Not in Low-power mode during Standby and Sleep 1 — Regulator in Low-power mode during Standby and Sleep
UNUSED	7 to 4	—	—	Unused

Table 101. Register LDO3_VOLT - ADDR 0x52

Name	Bit	R/W	Default	Description
LDO3_VOLT	4 to 0	RW1S	—	LDO3 output voltage setting register. Loaded from OTP. 00000 — See Table 33 for voltage settings 11111 — See Table 33 for voltage settings
UNUSED	7 to 5	—	—	Unused

Table 102. Register LDO3_CTRL - ADDR 0x53

Name	Bit	R/W	Default	Description
VLDO3_EN	0	RW1S	0	Enables LDO regulator. Loaded from OTP based on the sequence settings. User can turn regulator off by clearing this bit. 0 — Disables regulator 1 — Enables regulator
VLDO3_STBY_EN	1	RW1S	0	Enables LDO in Standby mode. Default value of this bit should be same as VLDO1_EN. 0 — Disables regulator 1 — Enables regulator
VLDO3_OMODE	2	RW	0	Enables LDO in Sleep mode 0 — Disables regulator 1 — Enables regulator
VLDO3_LPWR	3	RW	0	Forces LDO to Low-power mode in Sleep and Standby modes 0 — Not in Low-power mode during Standby and Sleep 1 — Regulator in Low-power mode during Standby and Sleep
LDO3_LS_EN	4	RW1S	0	This is loaded from OTP_LDOy_LS_EN and changeable from 0 to 1 on power up. Changing from 1 to 0 is not allowed. 0 — Sets LDOy in LDO mode 1 — Sets LDOy to a load switch (fully on) mode
UNUSED	7 to 5	—	—	Unused

Table 103. Register PWRCTRL0 - ADDR 0x58

Name	Bit	R/W	Default	Description
STANDBYDLY	1 to 0	RW	01	Controls delay of Standby pin after synchronization 0 — No additional delay 1 — 32 kHz cycle additional delay 2 — 32 kHz cycle additional delay 3 — 32 kHz cycle additional delay
STANDBYINV	2	RW	0	Controls polarity of STANDBY pin 0 — Standby pin input active high 1 — Standby pin input active low
POR_DLY	5 to 3	RW1S	000	Controls delay of RESETBMCU pin after power up (loaded from OTP) 000 — RESETBMCU goes high 2 ms after last regulator 010 — RESETBMCU goes high 4 ms after last regulator 011 — RESETBMCU goes high 8 ms after last regulator 100 — RESETBMCU goes high 16 ms after last regulator 101 — RESETBMCU goes high 128 ms after last regulator 110 — RESETBMCU goes high 256 ms after last regulator 111 — RESETBMCU goes high 1024 ms after last regulator
TGRESET	7 to 6	RW1S	00	Controls duration for which ONKEY has to be pushed low for a global reset (part goes to REGS_DISABLE) 00 — 4 s 01 — 8 s 10 — 12 s 11 — 16 s

Table 104. Register PWRCTRL1 - ADDR 0x59

Name	Bit	R/W	Default	Description
PWRONDBNC	1 to 0	RW	00	Controls debounce of PWRON when in push button mode (PWRON_CFG = 1) 00 — 31.25 ms falling edge; 31.25 ms rising edge 01 — 31.25 ms falling edge; 31.25 ms rising edge 10 — 125 ms falling edge; 31.25 ms rising edge 11 — 750 ms falling edge; 31.25 ms rising edge
ONKEYDBNC	3 to 2	RW	00	Controls debounce of ONKEY push button 00 — 31.25 ms falling edge; 31.25 ms rising edge 01 — 31.25 ms falling edge; 31.25 ms rising edge 10 — 125 ms falling edge; 31.25 ms rising edge 11 — 750 ms falling edge; 31.25 ms rising edge
PWRONRSTEN	4	RW	0	Enables going to REGS_DISABLE or Sleep mode when PWRON_CFG = 1. See Section 10 "PF1510 state machine" for details. 0 — Long press on PWRON button does not take state to REGS_DISABLE or Sleep 1 — Long press on PWRON button takes state to REGS_DISABLE or Sleep

Power management integrated circuit (PMIC) for low power application processors

Name	Bit	R/W	Default	Description
RESTARTEN	5	RW	0	Enables restart of system when PWRON push button is held low for 5 s 0 — No impact 1 — When going to REGS_DISABLE via a long press of PWRON button, holding it low for 1 more second takes state back to RUN (equally, a 5 second push restarts the system)
REGSCPEN	6	RW	0	Shuts down LDO if it enters a current limit fault. Controls LDO1, LDO2 and LDO3. 0 — LDO does not shutdown in the event of a current limit fault. Continues to limit current. 1 — LDO is turned off when it encounters a current limit fault
ONKEY_RST_EN	7	RW	1	Enables turning off of system via ONKEY. See Section 10 "PF1510 state machine" for details. 0 — ONKEY cannot be used to turn off or restart system 1 — ONKEY can be used to turn off or restart system

Table 105. Register PWRCTRL2 - ADDR 0x5A

Name	Bit	R/W	Default	Description
UVDET	1 to 0	RW1S	00	Sets UVDET threshold 00 — Rising 2.65 V; falling 2.55 V 01 — Rising 2.8 V; falling 2.7 V 10 — Rising 3.0 V; falling 2.9 V 11 — Rising 3.1 V; falling 3.0 V
LOW_SYS_WARN	3 to 2	RW	00	Sets LOW_SYS_WARN threshold 00 — Rising 3.3 V; falling 3.1 V 01 — Rising 3.5 V; falling 3.3 V 10 — Rising 3.7 V; falling 3.5 V 11 — Rising 3.9 V; falling 3.7 V
UNUSED	7 to 4	—	—	Unused

Table 106. Register PWRCTRL3 - ADDR 0x5B

Name	Bit	R/W	Default	Description
UNUSED	0	RW	0	Unused
GOTO_CORE_OFF	1	RW	0	Set this bit to go to CORE_OFF mode once in REGS_DISABLE state 0 — No impact 1 — PF1510 gracefully enters CORE_OFF mode when in REGS_DISABLE state
UNUSED	7 to 2	—	—	Unused

Table 107. Register SW1_PWRDN_SEQ - ADDR 0x5F

Name	Bit	R/W	Default	Description
SW1_PWRDN_SEQ	2 to 0	RW1S	000	<p>This contains same value as power-up sequence value by default. Power-up sequence is in mirror registers.</p> <p>xxx = The power-down sequencer performs the functional opposite to the power-up sequencer. Each regulator has an associated register setting (SW1_PWRDN_SEQ[2:0], SW2_PWRDN_SEQ[2:0], SW3_PWRDN_SEQ[2:0], LDO1_PWRDN_SEQ[2:0], LDO2_PWRDN_SEQ[2:0], LDO3_PWRDN_SEQ[2:0], VREFDDR_PWRDN_SEQ[2:0]) that sets its power-down sequence. The default setting of the above registers is equal to the corresponding power-up sequence setting. For example, SW1_PWRDN_SEQ[2:0] = OTP_SW1_PWRUP_SEQ[2:0].</p> <p>When the power-down sequencer is activated, regulators are turned off one by one in the descending order of the XXX_PWRDN_SEQ[2:0] setting. This way, by default, power-down is a mirror of the power-up sequence. In one of the "System On" states, the processor can change the values of the XXX_PWRDN_SEQ[2:0] registers. The power-up sequence is fixed by OTP (or TBB). If all XXX_PWRDN_SEQ[2:0] = 0x00, the power-down sequencer is bypassed and all the regulators are turned off at once.</p>
UNUSED	7 to 3	—	—	Unused

Table 108. Register SW2_PWRDN_SEQ - ADDR 0x60

Name	Bit	R/W	Default	Description
SW2_PWRDN_SEQ	2 to 0	RW1S	000	<p>This contains same value as power-up sequence value by default. Power-up sequence is in mirror registers.</p> <p>xxx = The power-down sequencer performs the functional opposite to the power-up sequencer. Each regulator has an associated register setting (SW1_PWRDN_SEQ[2:0], SW2_PWRDN_SEQ[2:0], SW3_PWRDN_SEQ[2:0], LDO1_PWRDN_SEQ[2:0], LDO2_PWRDN_SEQ[2:0], LDO3_PWRDN_SEQ[2:0], VREFDDR_PWRDN_SEQ[2:0]) that sets its power-down sequence. The default setting of the above registers is equal to the corresponding power-up sequence setting. For example, SW1_PWRDN_SEQ[2:0] = OTP_SW1_PWRUP_SEQ[2:0].</p> <p>When the power-down sequencer is activated, regulators are turned off one by one in the descending order of the XXX_PWRDN_SEQ[2:0] setting. This way, by default, power-down is a mirror of the power-up sequence. In one of the "System On" states, the processor can change the values of the XXX_PWRDN_SEQ[2:0] registers. The power-up sequence is fixed by OTP (or TBB). If all XXX_PWRDN_SEQ[2:0] = 0x00, the power-down sequencer is bypassed and all the regulators are turned off at once.</p>
UNUSED	7 to 3	—	—	Unused

Table 109. Register SW2_PWRDN_SEQ - ADDR 0x61

Name	Bit	R/W	Default	Description
SW3_PWRDN_SEQ	2 to 0	RW1S	000	<p>This contains same value as power-up sequence value by default. Power-up sequence is in mirror registers.</p> <p>xxx = The power-down sequencer performs the functional opposite to the power-up sequencer. Each regulator has an associated register setting (SW1_PWRDN_SEQ[2:0], SW2_PWRDN_SEQ[2:0], SW3_PWRDN_SEQ[2:0], LDO1_PWRDN_SEQ[2:0], LDO2_PWRDN_SEQ[2:0], LDO3_PWRDN_SEQ[2:0], VREFDDR_PWRDN_SEQ[2:0]) that sets its power-down sequence. The default setting of the above registers is equal to the corresponding power-up sequence setting. For example, SW1_PWRDN_SEQ[2:0] = OTP_SW1_PWRUP_SEQ[2:0].</p> <p>When the power-down sequencer is activated, regulators are turned off one by one in the descending order of the XXX_PWRDN_SEQ[2:0] setting. This way, by default, power-down is a mirror of the power-up sequence. In one of the "System On" states, the processor can change the values of the XXX_PWRDN_SEQ[2:0] registers. The power-up sequence is fixed by OTP (or TBB). If all XXX_PWRDN_SEQ[2:0] = 0x00, the power-down sequencer is bypassed and all the regulators are turned off at once.</p>
UNUSED	7 to 3	—	—	Unused

Table 110. Register LDO1_PWRDN_SEQ - ADDR 0x62

Name	Bit	R/W	Default	Description
LDO1_PWRDN_SEQ	2 to 0	RW1S	000	<p>This contains same value as power-up sequence value by default. Power-up sequence is in mirror registers.</p> <p>xxx = The power-down sequencer performs the functional opposite to the power-up sequencer. Each regulator has an associated register setting (SW1_PWRDN_SEQ[2:0], SW2_PWRDN_SEQ[2:0], SW3_PWRDN_SEQ[2:0], LDO1_PWRDN_SEQ[2:0], LDO2_PWRDN_SEQ[2:0], LDO3_PWRDN_SEQ[2:0], VREFDDR_PWRDN_SEQ[2:0]) that sets its power-down sequence. The default setting of the above registers is equal to the corresponding power-up sequence setting. For example, SW1_PWRDN_SEQ[2:0] = OTP_SW1_PWRUP_SEQ[2:0].</p> <p>When the power-down sequencer is activated, regulators are turned off one by one in the descending order of the XXX_PWRDN_SEQ[2:0] setting. This way, by default, power-down is a mirror of the power-up sequence. In one of the "System On" states, the processor can change the values of the XXX_PWRDN_SEQ[2:0] registers. The power-up sequence is fixed by OTP (or TBB). If all XXX_PWRDN_SEQ[2:0] = 0x00, the power-down sequencer is bypassed and all the regulators are turned off at once.</p>
UNUSED	7 to 3	—	—	Unused

Table 111. Register LDO2_PWRDN_SEQ - ADDR 0x63

Name	Bit	R/W	Default	Description
LDO2_PWRDN_SEQ	2 to 0	RW1S	000	<p>This contains same value as power-up sequence value by default. Power-up sequence is in mirror registers.</p> <p>xxx = The power-down sequencer performs the functional opposite to the power-up sequencer. Each regulator has an associated register setting (SW1_PWRDN_SEQ[2:0], SW2_PWRDN_SEQ[2:0], SW3_PWRDN_SEQ[2:0], LDO1_PWRDN_SEQ[2:0], LDO2_PWRDN_SEQ[2:0], LDO3_PWRDN_SEQ[2:0], VREFDDR_PWRDN_SEQ[2:0]) that sets its power-down sequence. The default setting of the above registers is equal to the corresponding power-up sequence setting. For example, SW1_PWRDN_SEQ[2:0] = OTP_SW1_PWRUP_SEQ[2:0].</p> <p>When the power-down sequencer is activated, regulators are turned off one by one in the descending order of the XXX_PWRDN_SEQ[2:0] setting. This way, by default, power-down is a mirror of the power-up sequence. In one of the "System On" states, the processor can change the values of the XXX_PWRDN_SEQ[2:0] registers. The power-up sequence is fixed by OTP (or TBB). If all XXX_PWRDN_SEQ[2:0] = 0x00, the power-down sequencer is bypassed and all the regulators are turned off at once.</p>
UNUSED	7 to 3	—	—	Unused

Table 112. Register LDO3_PWRDN_SEQ - ADDR 0x64

Name	Bit	R/W	Default	Description
LDO3_PWRDN_SEQ	2 to 0	RW1S	000	<p>This contains same value as power-up sequence value by default. Power-up sequence is in mirror registers.</p> <p>xxx = The power-down sequencer performs the functional opposite to the power-up sequencer. Each regulator has an associated register setting (SW1_PWRDN_SEQ[2:0], SW2_PWRDN_SEQ[2:0], SW3_PWRDN_SEQ[2:0], LDO1_PWRDN_SEQ[2:0], LDO2_PWRDN_SEQ[2:0], LDO3_PWRDN_SEQ[2:0], VREFDDR_PWRDN_SEQ[2:0]) that sets its power-down sequence. The default setting of the above registers is equal to the corresponding power-up sequence setting. For example, SW1_PWRDN_SEQ[2:0] = OTP_SW1_PWRUP_SEQ[2:0].</p> <p>When the power-down sequencer is activated, regulators are turned off one by one in the descending order of the XXX_PWRDN_SEQ[2:0] setting. This way, by default, power-down is a mirror of the power-up sequence. In one of the "System On" states, the processor can change the values of the XXX_PWRDN_SEQ[2:0] registers. The power-up sequence is fixed by OTP (or TBB). If all XXX_PWRDN_SEQ[2:0] = 0x00, the power-down sequencer is bypassed and all the regulators are turned off at once.</p>
UNUSED	7 to 3	—	—	Unused

Table 113. Register VREFDDR_PWRDN_SEQ - ADDR 0x65

Name	Bit	R/W	Default	Description
VREFDDR_PWRDN_SEQ	2 to 0	RW1S	000	<p>This contains same value as power-up sequence value by default. Power-up sequence is in mirror registers.</p> <p>xxx = The power-down sequencer performs the functional opposite to the power-up sequencer. Each regulator has an associated register setting (SW1_PWRDN_SEQ[2:0], SW2_PWRDN_SEQ[2:0], SW3_PWRDN_SEQ[2:0], LDO1_PWRDN_SEQ[2:0], LDO2_PWRDN_SEQ[2:0], LDO3_PWRDN_SEQ[2:0], VREFDDR_PWRDN_SEQ[2:0]) that sets its power-down sequence. The default setting of the above registers is equal to the corresponding power-up sequence setting. For example, SW1_PWRDN_SEQ[2:0] = OTP_SW1_PWRUP_SEQ[2:0].</p> <p>When the power-down sequencer is activated, regulators are turned off one by one in the descending order of the XXX_PWRDN_SEQ[2:0] setting. This way, by default, power-down is a mirror of the power-up sequence. In one of the "System On" states, the processor can change the values of the XXX_PWRDN_SEQ[2:0] registers. The power-up sequence is fixed by OTP (or TBB). If all XXX_PWRDN_SEQ[2:0] = 0x00, the power-down sequencer is bypassed and all the regulators are turned off at once.</p>
UNUSED	7 to 3	—	—	Unused

Table 114. Register STATE_INFO - ADDR 0x67

Name	Bit	R/W	Default	Description
STATE	5 to 0	R	000000	<p>Indicates machine state</p> <p>000000 — Wait state</p> <p>001100 — Run state</p> <p>001101 — Standby state</p> <p>001110 — Sleep/LPSR state</p> <p>101011 — REGS_DISABLE state</p> <p>Other bits are reserved</p>
UNUSED	7 to 6	—	—	Unused

Table 115. Register I2C_ADDR - ADDR 0x68

Name	Bit	R/W	Default	Description
I2C_SLAVE_ADDR_L SBS	2 to 0	R	000	<p>Loaded from fuses. But read only in functional space.</p> <p>000 — Slave Address: 0x08</p> <p>001 — Slave Address: 0x09</p> <p>010 — Slave Address: 0x0A</p> <p>011 — Slave Address: 0x0B</p> <p>100 — Slave Address: 0x0C</p> <p>101 — Slave Address: 0x0D</p> <p>110 — Slave Address: 0x0E</p> <p>111 — Slave Address: 0x0F</p>
USE_DEFAULT_ADDR	7	RW	0	DEFAULT ADDR

Table 116. Register RC_16MHZ - ADDR 0x6B

Name	Bit	R/W	Default	Description
REQ_16MHZ	0	RW	0	Enables 16 MHz clock 0 — 16 MHz clock enable controlled by state machine 1 — 16 MHz clock always enabled
REQ_ACORE_ON	1	RW	0	Controls Analog core enable 0 — Analog core enable controlled by state machine 1 — Analog core always on
REQ_ACORE_HIPWR	2	RW	0	Controls Low-power mode of the analog core 0 — Analog core Low-power mode controlled by state machine 1 — Analog core never in Low-power mode
UNUSED	7 to 3	—	—	Unused

Table 117. Register KEY1 - ADDR 0x6B

Name	Bit	R/W	Default	Description
KEY1	7 to 0	RW	0x00	Unused

12.2 Specific Registers (Offset is 0x80)

Table 118. Register INT - ADDR 0x00

Name	Bit	R/W	Default	Description
RSVD0	0	RW1S ^[1]	0	Unused
RSVD1	1			
RSVD2	2			
RSVD3	3			
RSVD4	4			
VIN_I	5	RW1S	0	VIN interrupt 0 — The VIN_OK interrupt has not occurred or been cleared 1 — The VIN_OK interrupt has occurred Reset condition — VCOREDIG_RSTB
RSVD6	6	RW1S	0	Unused
RSVD7	7	RW1S	0	Unused

[1] Load from OTP fuse, Read and Write

Table 119. Register INT_MASK - ADDR 0x02

Name	Bit	R/W	Default	Description
RSVD0	0	RW	1	Unused
RSVD1	1			
RSVD2	2			
RSVD3	3			
RSVD4	4			

Power management integrated circuit (PMIC) for low power application processors

Name	Bit	R/W	Default	Description
VIN_M	5	RW	1	VIN interrupt mask 0 — Unmasked 1 — Masked Reset condition — VCOREDIG_RSTB
RSVD6	6	RW	1	Unused
RSVD7	7	RW	1	Unused

Table 120. Register INT_OK - ADDR 0x04

Name	Bit	R/W	Default	Description
RSVD0	0	R	0	Unused
RSVD1	1		0	
RSVD2	2		1	
RSVD3	3		0	
RSVD4	4		0	
VIN_OK	5	R	0	Single bit VIN status indicator. See VIN_SNS for more information. 0 — The VIN input is invalid. For example, VIN_VALID = 0. 1 — The VIN input is valid. For example, VIN_VALID = 1. Reset condition — VCOREDIG_RSTB
RSVS6	6	R	0	Unused
RSVD7	7	R	1	Unused

Table 121. Register VIN_SNS - ADDR 0x06

Name	Bit	R/W	Default	Description
RSVD[1:0]	1 to 0	R	00	Unused
VIN_UVLO_SNS	2	R	1	0 — VIN > VIN_UVLO 1 — VIN < VIN_UVLO or when VIN is detached
VIN2SYS_SNS	3	R	1	0 — VIN > VSYS + VIN2SYS 1 — VIN < VSYS + VIN2SYS
VIN_OVLO_SNS	4	R	0	0 — VIN < VIN_OVLO 1 — VIN > VIN_OVLO
VIN_VALID	5	R	0	0 — VIN is not valid 1 — VIN is valid, VIN > VIN_UVLO, VIN > VSYS + VIN2SYS, VIN < VIN_OVLO Reset condition — VCOREDIG_RSTB
RSVD6	6	R	0	Unused
RSVD7	7	R	0	Unused

Table 122. Register FRONT_END_OPER- ADDR 0x09

Name	Bit	R/W	Default	Description
FRONT_END_ON	1 to 0	RW1S ^[1]	01	Front-end LDO operation configuration 0 — Front-end LDO is OFF 1 — Front-end LDO is ON 2 — Reserved 3 — Reserved Reset condition — VCOREDIG_RSTB
RSVD2	2	RW	0	Unused
RSVD3	3		0	
RSVD4	4		0	
RSVD[7:5]	7 to 5		000	

[1] Load from OTP fuse, Read and Write

Table 123. Register FRONT_END_REG - ADDR 0x0F

Name	Bit	R/W	Default	Description
RSVD[5:0]	5 to 0	RW1S	101011	Unused
VSYSMIN	7 to 6	RW1S	00	Minimum system regulation voltage ($V_{SYS_{MIN}}$) 0 — 3.5 V 1 — 3.7 V 2 — 4.3 V 3 — Reserved Reset condition — VCOREDIG_RSTB

Table 124. Register VIN_INLIM_CNFG - ADDR 0x14

Name	Bit	R/W	Default	Description
RSVD[2:0]	2 to 0	RW	000	Unused

Name	Bit	R/W	Default	Description
VIN_ILIM	7 to 3	RW1S	01101	Maximum input current limit selection. 5 bit adjustment from 10 mA to 1500 mA. 0 — 10 mA 1 — 15 mA 2 — 20 mA 3 — 25 mA 4 — 30 mA 5 — 35 mA 6 — 40 mA 7 — 45 mA 8 — 50 mA 9 — 100 mA 10 — 150 mA 11 — 200 mA 12 — 300 mA 13 — 400 mA 14 — 500 mA 15 — 600 mA 16 — 700 mA 17 — 800 mA 18 — 900 mA 19 — 1000 mA 20 — 1500 mA 21 — Reserved 22 — Reserved 23 — Reserved 24 — Reserved 25 — Reserved 26 — Reserved 27 — Reserved 28 — Reserved 29 — Reserved 30 — Reserved 31 — Reserved Reset condition — CHGPOK_RSTB

Table 125. Register USB_PHY_LDO_CNFG - ADDR 0x16

Name	Bit	R/W	Default	Description
RSVD0	0	RW1S	1	Unused
USBPHY	1	RW1S	0	USBPHY voltage setting register 0 — 3.3 V 1 — 4.9 V Reset condition — VCOREDIG_RSTB
USBPHYLDO	2	RW1S	0	USBPHY LDO enable 0 — Disabled 1 — Enabled Reset condition — VCOREDIG_RSTB

Name	Bit	R/W	Default	Description
RSVD3	3	RW	0	Unused
RSVD[5:4]	5 to 4		00	
RSVD[7:6]	7 to 6		00	

Table 126. Register DBNC_DELAY_TIME - ADDR 0x18

Name	Bit	R/W	Default	Description
VIN_OV_TDB	1 to 0	RW1S	00	VIN overvoltage debounce delay 0 — 10 μ s (reserved) 1 — 100 μ s 2 — 1 ms 3 — 10 ms Reset condition — VCOREDIG_RSTB
USB_PHY_TDB	3 to 2	RW1S	00	USBPHY debounce timer - not used in PF1510 0 — 0 ms 1 — 16 ms 2 — 32 ms 3 — Not used Reset condition — VCOREDIG_RSTB
SYS_WKUP_DLY	5 to 4	RW1S	00	System wake-up time 0 — 8.0 ms 1 — 16 ms 2 — 32 ms 3 — 100 ms Reset condition — VCOREDIG_RSTB
RSVD[7:6]	7 to 6	RW	00	Unused

Table 127. Register VIN2SYS_CNFG - ADDR 0x1B

Name	Bit	R/W	Default	Description
VIN2SYS_TDB	1 to 0	RW1S	00	VIN to VSYS comparator debounce time 0 — Reserved 1 — 100 μ s 2 — 1 ms 3 — 10 ms Reset condition — VCOREDIG_RSTB
VIN2SYS_THRSH	2	RW1S	0	VIN to VSYS comparator threshold setting 0 — 50 mV 1 — 175 mV Reset condition — VCOREDIG_RSTB
RSVD[7:3]	7 to 3	RW	00000	Unused

12.3 Register PMIC bitmap

- VCOREDIG_PORB ^[1]
- PS_END_RSTB ^[2]
- REGS_DISABLE_TOG_RSTB ^[3]

- [1] Bits reset by invalid VCOREDIG
- [2] Bits reset by PORB or RESETBMCU
- [3] Bits reset by pulse to REGS_DISABLE mode

Table 128. Register PMIC bitmap

Address	Register name	BITS[7:0]								
		7	6	5	4	3	2	1	0	
0x00	DEVICE_ID	Name	FAMILY[3:7]				DEVICE_ID[2:0]			
		Reset	0	1	1	1	1	1	0	0
		Type	R	R	R	R	R	R	R	R
0x01	OTP_FLAVOR	Name	OTP_FLAVOR[5:0]							
		Reset	0	0	0	0	0	0	0	0
		Type	—	—	R	R	R	R	R	R
0x02	SILICON_REV	Name	FAB_FIN[7:6]		FULL_LAYER_REV[5:3]			METAL_LAYER_REV[2:0]		
		Reset	0	0	0	0	1	0	0	0
		Type	R	R	R	R	R	R	R	R
0x06	INT_CATEGORY	Name	MISC_INT	TEMP_INT	ONKEY_INT	LDO_INT	SW3_INT	SW2_INT	SW1_INT	VIN_INT
		Reset	0	0	0	0	0	0	0	0
		Type	R	R	R	R	R	R	R	R
0x08	SW_INT_STAT0	Name	—	—	—	—	—	SW3_LS_I	SW2_LS_I	SW1_LS_I
		Reset	0	0	0	0	0	0	0	0
		Type	—	—	—	—	—	RW1C	RW1C	RW1C
0x09	SW_INT_MASK0	Name	—	—	—	—	—	SW3_LS_M	SW2_LS_M	SW1_LS_M
		Reset	0	0	0	0	0	1	1	1
		Type	—	—	—	—	—	RW	RW	RW
0x0A	SW_INT_SENSE0	Name	—	—	—	—	—	SW3_LS_S	SW2_LS_S	SW1_LS_S
		Reset	0	0	0	0	0	0	0	0
		Type	—	—	—	—	—	R	R	R
0x0B	SW_INT_STAT1	Name	—	—	—	—	—	SW3_HS_I	SW2_HS_I	SW1_HS_I
		Reset	0	0	0	0	0	0	0	0
		Type	—	—	—	—	—	RW1C	RW1C	RW1C
0x0C	SW_INT_MASK1	Name	—	—	—	—	—	SW3_HS_M	SW2_HS_M	SW1_HS_M
		Reset	0	0	0	0	0	1	1	1
		Type	—	—	—	—	—	RW	RW	RW
0x0D	SW_INT_SENSE1	Name	—	—	—	—	—	SW3_HS_S	SW2_HS_S	SW1_HS_S
		Reset	0	0	0	0	0	0	0	0
		Type	—	—	—	—	—	R	R	R
0x0E	SW_INT_STAT2	Name	—	—	—	—	—	—	SW2_DVS_DONE_I	SW1_DVS_DONE_I
		Reset	0	0	0	0	0	0	0	0
		Type	—	—	—	—	—	—	RW1C	RW1C
0x0F	SW_INT_MASK2	Name	—	—	—	—	—	—	SW2_DVS_DONE_M	SW1_DVS_DONE_M
		Reset	0	0	0	0	0	0	1	1
		Type	—	—	—	—	—	—	RW	RW

Power management integrated circuit (PMIC) for low power application processors

Address	Register name	BITS[7:0]								
		7	6	5	4	3	2	1	0	
0x10	SW_INT_SENSE2	Name	—	—	—	—	—	—	SW2_DVS_S	SW1_DVS_S
		Reset	0	0	0	0	0	0	0	0
		Type	—	—	—	—	—	—	R	R
0x18	LDO_INT_STAT0	Name	—	—	—	—	—	LDO3_FAULTI	LDO2_FAULTI	LDO1_FAULTI
		Reset	0	0	0	0	0	0	0	0
		Type	—	—	—	—	—	RW1C	RW1C	RW1C
0x19	LDO_INT_MASK0	Name	—	—	—	—	—	LDO3_FAULTM	LDO2_FAULTM	LDO1_FAULTM
		Reset	0	0	0	0	0	1	1	1
		Type	—	—	—	—	—	RW	RW	RW
0x1A	LDO_INT_SENSE0	Name	—	—	—	—	—	LDO3_FAULTS	LDO2_FAULTS	LDO1_FAULTS
		Reset	0	0	0	0	0	0	0	0
		Type	—	—	—	—	—	R	R	R
0x20	TEMP_INT_STAT0	Name	—	—	—	—	—	THERM125I	—	THERM110I
		Reset	0	0	0	0	0	0	0	0
		Type	—	—	—	—	—	RW1C	—	RW1C
0x21	TEMP_INT_MASK0	Name	—	—	—	—	—	THERM125M	—	THERM110M
		Reset	0	0	0	0	1	1	1	1
		Type	—	—	—	—	—	RW	—	RW
0x22	TEMP_INT_SENSE0	Name	—	—	—	—	—	THERM125S	—	THERM110S
		Reset	0	0	0	0	0	0	0	0
		Type	—	—	—	—	—	R	—	R
0x24	ONKEY_INT_STAT0	Name	—	—	ONKEY_8SI	ONKEY_4SI	ONKEY_3SI	ONKEY_2SI	ONKEY_1SI	ONKEY_PUSHI
		Reset	0	0	0	0	0	0	0	0
		Type	—	—	RW1C	RW1C	RW1C	RW1C	RW1C	RW1C
0x25	ONKEY_INT_MASK0	Name	—	—	ONKEY_8SM	ONKEY_4SM	ONKEY_3SM	ONKEY_2SM	ONKEY_1SM	ONKEY_PUSHM
		Reset	0	0	1	1	1	1	1	1
		Type	—	—	RW	RW	RW	RW	RW	RW
0x26	ONKEY_INT_SENSE0	Name	—	—	ONKEY_8SS	ONKEY_4SS	ONKEY_3SS	ONKEY_2SS	ONKEY_1SS	ONKEY_PUSHS
		Reset	0	0	0	0	0	0	0	0
		Type	—	—	R	R	R	R	R	R
0x28	MISC_INT_STAT0	Name	—	—	—	SYS_OVLO_I	LOW_SYS_WARN_I	PWRON_I	PWRDN_I	PWRUP_I
		Reset	0	0	0	0	0	0	0	0
		Type	—	—	—	RW1C	RW1C	RW1C	RW1C	RW1C
0x29	MISC_INT_MASK0	Name	—	—	—	SYS_OVLO_M	LOW_SYS_WARN_M	PWRON_M	PWRDN_M	PWRUP_M
		Reset	0	0	0	1	1	1	1	1
		Type	—	—	—	RW	RW	RW	RW	RW
0x2A	MISC_INT_SENSE0	Name	—	—	—	SYS_OVLO_S	LOW_SYS_WARN_S	PWRON_S	PWRDN_S	PWRUP_S
		Reset	0	0	0	0	0	0	0	0
		Type	—	—	—	R	R	R	R	R
0x30	COINCELL_CONTROL	Name	—	—	—	COINCHEN				VCOIN[3:0]
		Reset	0	0	0	0	0	0	0	0
		Type	—	—	—	RW	RW	RW	RW	RW
0x32	SW1_VOLT	Name	—	—	SW1_VOLT[5:0]					—
		Reset	0	0	0	0	0	0	0	0
		Type	—	—	RW1S	RW1S	RW1S	RW1S	RW1S	RW1S
0x33	SW1_STBY_VOLT	Name	—	—	SW1_STBY_VOLT[5:0]					—
		Reset	0	0	0	0	0	0	0	0
		Type	—	—	RW1S	RW1S	RW1S	RW1S	RW1S	RW1S

Power management integrated circuit (PMIC) for low power application processors

Address	Register name		BITS[7:0]							
			7	6	5	4	3	2	1	0
0x34	SW1_SLP_VOLT	Name	—	—	SW1_SLP_VOLT[5:0]					
		Reset	0	0	0	0	0	0	0	0
		Type	—	—	RW1S	RW1S	RW1S	RW1S	RW1S	RW1S
0x35	SW1_CTRL	Name	SW1_RDIS_ENB	SW1_FPWM	SW1_FPWM_IN_DVS	SW1_DVSSPEED	SW1_LPWR	SW1_OMODE	SW1_STBY_EN	SW1_EN
		Reset	0	0	0	0	0	0	0	0
		Type	RW1S	RW	RW	RW1S	RW	RW	RW1S	RW1S
0x36	SW1_CTRL1	Name	—	—	—	SW1_TMODE_SEL	—	—	SW1_ILIM[1:0]	
		Reset	0	0	0	0	0	0	0	0
		Type	—	—	—	RW	—	—	RW1S	RW1S
0x38	SW2_VOLT	Name	—	—	SW2_VOLT[5:0]					
		Reset	0	0	0	0	0	0	0	0
		Type	—	—	RW1S	RW1S	RW1S	RW1S	RW1S	RW1S
0x39	SW2_STBY_VOLT	Name	—	—	SW2_STBY_VOLT[5:0]					
		Reset	0	0	0	0	0	0	0	0
		Type	—	—	RW1S	RW1S	RW1S	RW1S	RW1S	RW1S
0x3A	SW2_SLP_VOLT	Name	—	—	SW2_SLP_VOLT[5:0]					
		Reset	0	0	0	0	0	0	0	0
		Type	—	—	RW1S	RW1S	RW1S	RW1S	RW1S	RW1S
0x3B	SW2_CTRL	Name	SW2_RDIS_ENB	SW2_FPWM	SW2_FPWM_IN_DVS	SW2_DVSSPEED	SW2_LPWR	SW2_OMODE	SW2_STBY_EN	SW2_EN
		Reset	0	0	0	0	0	0	0	0
		Type	RW1S	RW	RW	RW1S	RW	RW	RW1S	RW1S
0x3C	SW2_CTRL1	Name	—	—	—	SW2_TMODE_SEL	—	—	SW2_ILIM[1:0]	
		Reset	0	0	0	0	0	0	0	0
		Type	—	—	—	RW	—	—	RW1S	RW1S
0x3E	SW3_VOLT	Name	—	—	—	—	SW3_VOLT[3:0]			
		Reset	0	0	0	0	0	0	0	0
		Type	—	—	—	—	RW1S	RW1S	RW1S	RW1S
0x3F	SW3_STBY_VOLT	Name	—	—	—	—	SW3_STBY_VOLT[3:0]			
		Reset	0	0	0	0	0	0	0	0
		Type	—	—	—	—	RW1S	RW1S	RW1S	RW1S
0x40	SW3_SLP_VOLT	Name	—	—	—	—	SW3_SLP_VOLT[3:0]			
		Reset	0	0	0	0	0	0	0	0
		Type	—	—	—	—	RW1S	RW1S	RW1S	RW1S
0x41	SW3_CTRL	Name	SW3_RDIS_ENB	SW3_FPWM	—	SW3_DVSSPEED	SW3_LPWR	SW3_OMODE	SW3_STBY_EN	SW3_EN
		Reset	0	0	0	0	0	0	0	0
		Type	RW1S	RW	—	RW1S	RW	RW	RW1S	RW1S
0x42	SW3_CTRL1	Name	—	—	—	SW3_TMODE_SEL	—	—	SW3_ILIM[1:0]	
		Reset	0	0	0	0	0	0	0	0
		Type	—	—	—	RW	—	—	RW1S	RW1S
0x48	VSNVS_CTRL	Name	—	—	LIBGDIS	FORCEBOS	CLKPULSE	VSNVS_VOLT[2:0]		
		Reset	0	0	0	0	0	0	0	0
		Type	—	—	RW	RW	RW	RW1S	RW1S	RW1S
0x4A	VREFDDR_CTRL	Name	—	—	—	—	VREFDDR_LPWR	VREFDDR_OMODE	VREFDDR_STBY_EN	VREFDDR_EN
		Reset	0	0	0	0	0	0	0	0
		Type	—	—	—	—	RW	RW	RW1S	RW1S
0x4C	LDO1_VOLT	Name	—	—	—	LDO1_VOLT[4:0]				
		Reset	0	0	0	0	0	0	0	

Power management integrated circuit (PMIC) for low power application processors

Address	Register name		BITS[7:0]							
			7	6	5	4	3	2	1	0
		Type	—	—	—	RW1S	RW1S	RW1S	RW1S	RW1S
0x4D	LDO1_CTRL	Name	—	—	—	LDO1_LS_EN	LDO1_LPWR	LDO1_OMODE	LDO1_STB_Y_EN	VLDO1_EN
		Reset	0	0	0	0	0	0	0	0
		Type	—	—	—	RW1S	RW	RW	RW1S	RW1S
0x4F	LDO2_VOLT	Name	—	—	—	—	LDO2_VOLT[3:0]			
		Reset	0	0	0	0	0	0	0	0
		Type	—	—	—	—	RW1S	RW1S	RW1S	RW1S
0x50	LDO2_CTRL	Name	—	—	—	—	LDO2_LPWR	LDO2_OMODE	LDO2_STB_Y_EN	VLDO2_EN
		Reset	0	0	0	0	0	0	0	0
		Type	—	—	—	—	RW	RW	RW1S	RW1S
0x52	LDO3_VOLT	Name	—	—	—	LDO3_VOLT[4:0]				
		Reset	0	0	0	0	0	0	0	0
		Type	—	—	—	RW1S	RW1S	RW1S	RW1S	RW1S
0x53	LDO3_CTRL	Name	—	—	—	LDO3_LS_EN	LDO3_LPWR	LDO3_OMODE	LDO3_STB_Y_EN	VLDO3_EN
		Reset	0	0	0	0	0	0	0	0
		Type	—	—	—	RW1S	RW	RW	RW1S	RW1S
0x58	PWRCTRL0	Name	TGRESET[7:6]		POR_DLY[5:3]			STANDBYINV	STANDBYDLY[1:0]	
		Reset	0	0	0	0	0	0	0	1
		Type	RW1S	RW1S	RW1S	RW1S	RW1S	RW	RW	RW
0x59	PWRCTRL1	Name	ONKEY_RST_EN	REGSCPEN	RESTARTEN	PWRONRSTEN	ONKEYBNC[3:2]		PWRONDBNC[1:0]	
		Reset	1	0	0	0	0	0	0	0
		Type	RW	RW	RW	RW	RW	RW	RW	RW
015A	PWRCTRL2	Name	—	—	—	—	LOW_SYS_WARN[3:2]		UVDET[1:0]	
		Reset	0	0	0	0	0	0	0	0
		Type	—	—	—	—	RW	RW	RW1S	RW1S
0x5B	PWRCTRL3	Name	—						GOTO_CORE_OFF	—
		Reset	0	0	0	0	0	0	0	0
		Type	RW	RW	RW	RW	RW	RW	RW	RW
0x5F	SW1_PWRDN_SEQ	Name	—	—	—	—	—	SW1_PWRDN_SEQ[2:0]		
		Reset	0	0	0	0	0	0	0	0
		Type	—	—	—	—	—	RW1S	RW1S	RW1S
0x60	SW2_PWRDN_SEQ	Name	—	—	—	—	—	SW2_PWRDN_SEQ[2:0]		
		Reset	0	0	0	0	0	0	0	0
		Type	—	—	—	—	—	RW1S	RW1S	RW1S
0x61	SW3_PWRDN_SEQ	Name	—	—	—	—	—	SW3_PWRDN_SEQ[2:0]		
		Reset	0	0	0	0	0	0	0	0
		Type	—	—	—	—	—	RW1S	RW1S	RW1S
0x62	LDO1_PWRDN_SEQ	Name	—	—	—	—	—	LDO1_PWRDN_SEQ[2:0]		
		Reset	0	0	0	0	0	0	0	0
		Type	—	—	—	—	—	RW1S	RW1S	RW1S
0x63	LDO2_PWRDN_SEQ	Name	—	—	—	—	—	LDO2_PWRDN_SEQ[2:0]		
		Reset	0	0	0	0	0	0	0	0
		Type	—	—	—	—	—	RW1S	RW1S	RW1S
0x64	LDO3_PWRDN_SEQ	Name	—	—	—	—	—	LDO3_PWRDN_SEQ[2:0]		
		Reset	0	0	0	0	0	0	0	0
		Type	—	—	—	—	—	RW1S	RW1S	RW1S
0x65	VREFDDR_PWRDN_SEQ	Name	—	—	—	—	—	VREFDDR_PWRDN_SEQ[2:0]		
		Reset	0	0	0	0	0	0	0	0

Power management integrated circuit (PMIC) for low power application processors

Address	Register name		BITS[7:0]								
			7	6	5	4	3	2	1	0	
		Type	—	—	—	—	—	—	RW1S	RW1S	RW1S
0x67	STATE_INFO	Name	—	—	STATE[5:0]						
		Reset	0	0	0	0	0	0	0	0	0
		Type	—	—	R	R	R	R	R	R	R
0x68	I2C_ADDR	Name	USE_DEFAULT_ADDR	—	—	—	—	—	I2C_SLAVE_ADDR_LSBS[2:0]		
		Reset	0	0	0	0	0	0	0	0	0
		Type	RW	—	—	—	—	—	R	R	R
0x69	IO_DRV0	Name	—	—	—	—	—	—	—	—	—
		Reset	0	0	0	0	0	0	0	0	0
		Type	—	—	—	—	—	—	—	—	—
0x6A	IO_DRV1	Name	—	—	—	—	—	—	—	—	—
		Reset	0	0	0	0	0	0	0	0	0
		Type	—	—	—	—	—	—	—	—	—
0x6B	RC_16MHZ	Name	—	—	—	—	—	—	REQ_ACORE_HIPWR	REQ_ACORE_ON	REQ_16MHZ
		Reset	0	0	0	0	0	0	0	0	0
		Type	—	—	—	—	—	—	RW	RW	RW
0x6F	KEY1	Name	KEY1[7:0]								
		Reset	0	0	0	0	0	0	0	0	0
		Type	RW	RW	RW	RW	RW	RW	RW	RW	RW

12.4 Additional register bitmap

CHGPOK_RSTB ^[1]
 VCOREDIG_RSTB ^[2]

[1] Bits reset by invalid VIN
 [2] Bits reset by invalid VCOREDIG

Table 129. Additional register bitmap

Address	Register name	BITS[7:0]								
		7	6	5	4	3	2	1	0	
0x00	INT	Name	RSVD7	RSVD6	VIN_I	RSVD4	RSVD3	RSVD2	RSVD1	RSVD0
		Reset	0	0	0	0	0	0	0	0
		Type	RW1C	RW1C	RW1C	RW1C	RW1C	RW1C	RW1C	RW1C
0x02	INT_MASK	Name	RSVD7	RSVD6	VIN_M	RSVD4	RSVD3	RSVD2	RSVD1	RSVD0
		Reset	1	1	1	1	1	1	1	1
		Type	RW	RW	RW	RW	RW	RW	RW	RW
0x04	INT_OK	Name	RSVD7	RSVD6	VIN_OK	RSVD4	RSVD3	RSVD2	RSVD1	RSVD0
		Reset	1	0	0	0	0	1	0	0
		Type	R	R	R	R	R	R	R	R
0x06	VIN_SNS	Name	RSVD7	RSVD6	VIN2SYS_SNS	VIN_OVLO_SNS	VIN_IN2SYS_SNS	VIN_UVLO_SNS	RSVD[1:0]	
		Reset	0	0	0	0	1	1	0	0
		Type	R	R	R	R	R	R	R	R
0x09	FRONT_END_OPER	Name	RSVD[7:5]			RSVD4	RSVD3	RSVD2	FRONT_END_ON[1:0]	
		Reset	0	0	0	0	0	0	0	1
		Type	RW	RW	RW	RW	RW	RW	RW1S	RW1S
0x0F	FRONT_END_REG	Name	VSYSTEMIN[7:6]			RSVD[5:0]				
		Reset	0	0	1	0	1	0	1	1
		Type	RW1S	RW1S	RW1S	RW1S	RW1S	RW1S	RW1S	RW1S
0x14	VIN_INLIM_CNFG	Name	VIN_ILIM[7:3]				RSVD[2:0]			
		Reset	0	1	1	0	1	0	0	0
		Type	RW1S	RW1S	RW1S	RW1S	RW1S	RW	RW	RW
0x16	USB_PHY_LDO_CNFG	Name	RSVD[7:6]		RSVD[5:4]		RSVD3	USBPHYLDO	USBPHY	RSVD0
		Reset	0	0	0	0	0	0	0	1
		Type	RW	RW	RW	RW	RW	RW1S	RW1S	RW1S
0x18	DBNC_DELAY_TIME	Name	RSVD[7:6]		SYS_WKUP_DLY[5:4]		USB_PHY_TDB[3:2]		VIN_OV_TDB[1:0]	
		Reset	0	0	0	0	0	0	0	0
		Type	RW	RW	RW1S	RW1S	RW1S	RW1S	RW1S	RW1S
0x1B	VIN2SYS_CNFG	Name	RSVD[7:3]				VIN2SYS_THRSH	VIN2SYS_TDB[1:0]		
		Reset	0	0	0	0	0	0	0	0
		Type	RW	RW	RW	RW	RW	RW1S	RW1S	RW1S

13 Application details

13.1 Example schematic

[Figure 16](#) shows a typical schematic of the PF1510 with key external components.

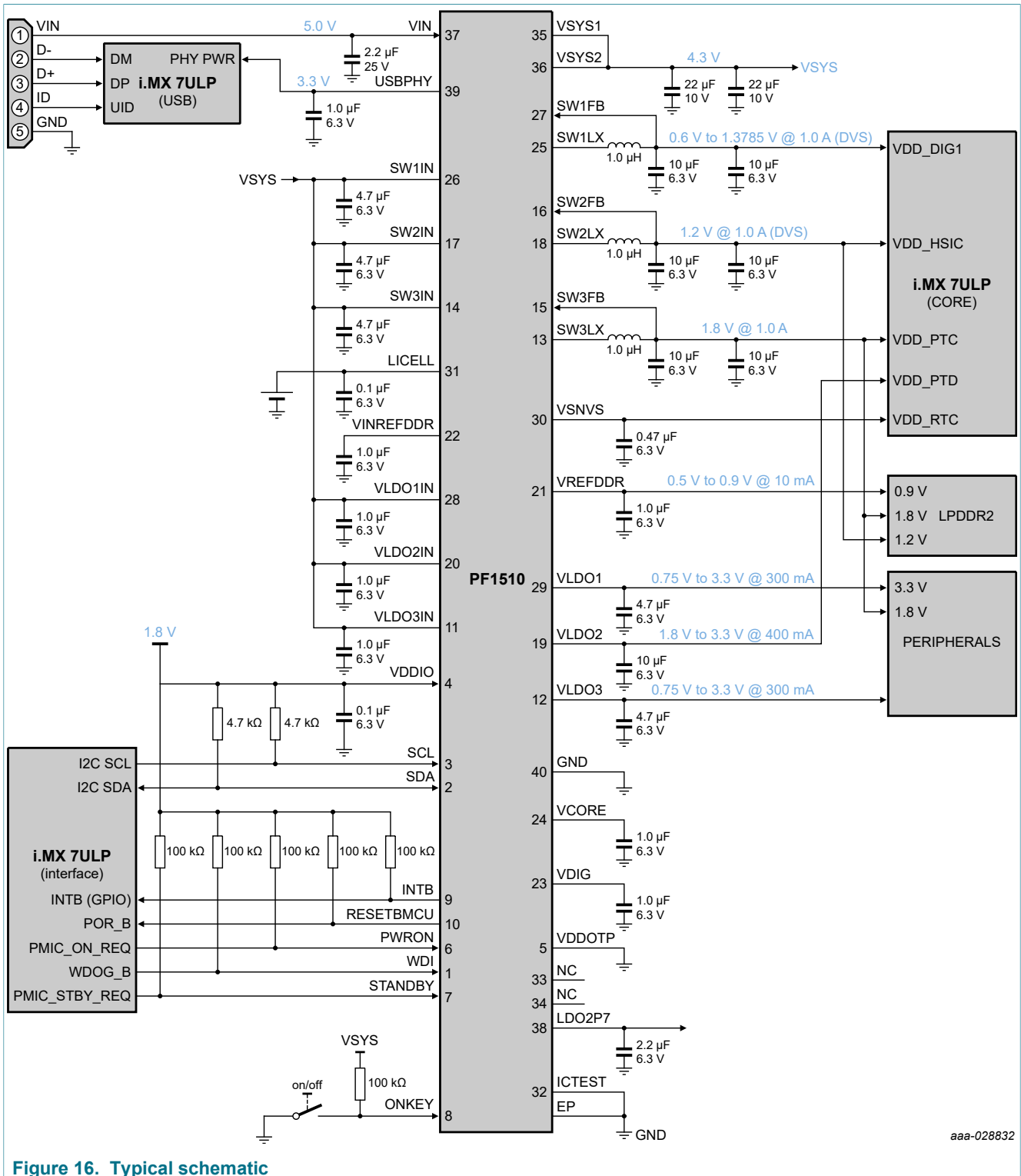

aaa-028832

Figure 16. Typical schematic

13.2 Bill of materials

The table below shows an example bill of materials to be used with the PF1510.

Table 130. Bill of materials

Block	Function	Description	Qty
VCORE	Analog IC supply	CAP CER 1.0 μ F 6.3 V 20 % X5R 0201	1
VDIG	Digital IC supply	CAP CER 1.0 μ F 6.3 V 20 % X5R 0201	1
LDO2P7	Analog supply	CAP CER 2.2 μ F 6.3 V 20% X5R 0201	1
USBPHY	USB PHY output capacitor	CAP CER 1.0 μ F 6.3 V 20 % X5R 0201	1
VIN	VIN bypass capacitor	CAP CER 2.2 μ F 25 V 20 % X5R 0402	1
VSYS	VSYS capacitor	22 μ F, 10 V, MLCC, X5R	2
VDDIO	VDDIO bypass capacitor	CAP CER 0.1 μ F 6.3 V 20 % X5R 0201	1
Buck 1	BUCK1 inductor	1.0 μ H, +/-20 %, 120 mOhm typ, 1700 mA	1
	BUCK1 input capacitor	4.7 μ F, 6.3 V, MLCC, X5R	1
	BUCK1 output capacitor	10 μ F, 6.3 V, MLCC, X5R	2
Buck 2	BUCK2 inductor	1.0 μ H, +/-20 %, 120 mOhm typ, 1700 mA	1
	BUCK2 input capacitor	4.7 μ F, 6.3 V, MLCC, X5R	1
	BUCK2 output capacitor	10 μ F, 6.3V, MLCC, X5R	2
Buck 3	BUCK3 inductor	1.0 μ H, +/-20 %, 120 mOhm typ, 1700 mA	1
	BUCK3 input capacitor	4.7 μ F, 6.3 V, MLCC, X5R	1
	BUCK3 output capacitor	10 μ F, 6.3 V, MLCC, X5R	2
LDO1	LDO1 input capacitor	CAP CER 1.0 μ F 6.3 V 20 % X5R 0201	1
	LDO1 output capacitor	4.7 μ F, 6.3 V, MLCC, X5R	1
LDO2	LDO2 input capacitor	CAP CER 1.0 μ F 6.3 V 20 % X5R 0201	1
	LDO2 output capacitor	10 μ F, 6.3 V, MLCC, X5R	1
LDO3	LDO3 input capacitor	CAP CER 1.0 μ F 6.3 V 20 % X5R 0201	1
	LDO3 output capacitor	4.7 μ F, 6.3 V, MLCC, X5R	1
VREFDDR	VREFDDR input capacitor	CAP CER 1.0 μ F 6.3 V 20 % X5R 0201	1
	VREFDDR output capacitor	CAP CER 1.0 μ F 6.3 V 20 % X5R 0201	1
VSNVS	VSNVS output capacitor	CAP CER 0.47 μ F 6.3 V 20 % X5R 0201	1
LICELL	LICELL bypass capacitor	CAP CER 0.1 μ F 6.3 V 20 % X5R 0201	1

13.3 PF1510 layout guidelines

13.3.1 General board recommendations

- It is recommended to use an eight layer board stack-up arranged as follows:
 - High current signal
 - GND
 - Signal
 - Power
 - Power
 - Signal
 - GND

Power management integrated circuit (PMIC) for low power application processors

- Allocate TOP and BOTTOM PCB layers for POWER ROUTING (high current signals), copper-pour the unused area.
- Use internal layers sandwiched between two GND planes for the SIGNAL routing.

13.3.2 Component placement

It is desirable to keep all component related to the power stage as close to the PMIC as possible, specially decoupling input and output capacitors.

13.3.3 General routing requirements

- Some recommended things to keep in mind for manufacturability:
 - Via in pads require a 4.5 mil minimum annular ring. Pad must be 9.0 mils larger than the hole
 - Maximum copper thickness for lines less than 5.0 mils wide is 0.6 oz copper
 - Minimum allowed spacing between line and hole pad is 3.5 mils
 - Minimum allowed spacing between line and line is 3.0 mils
- Care must be taken with SWx_{FB} pins traces. These signals are susceptible to noise and must be routed far away from power, clock, or high power signals, like the ones on the SWx_{IN}, SWx_{LX}. They could be also shielded.
- Shield feedback traces of the regulators and keep them as short as possible (trace them on the bottom so the ground and power planes shield these traces).
- Avoid coupling traces between important signal/low noise supplies (like V_{CORE}, V_{DIG}) from any switching node (for example, SW1_{LX}, SW2_{LX}, SW3_{LX}).
- Make sure that all components related to a specific block are referenced to the corresponding ground.

13.3.4 Parallel routing requirements

- I²C signal routing
 - CLK is the fastest signal of the system, so it must be given special care.
 - To avoid contamination of these delicate signals by nearby high power or high frequency signals, it is a good practice to shield them with ground planes placed on adjacent layers. Make sure the ground plane is uniform throughout the whole signal trace length.
 - These signals can be placed on an outer layer of the board to reduce their capacitance with respect to the ground plane.
 - Care must be taken with these signals not to contaminate analog signals, as they are high frequency signals. Another good practice is to trace them perpendicularly on different layers, so there is a minimum area of proximity between signals.

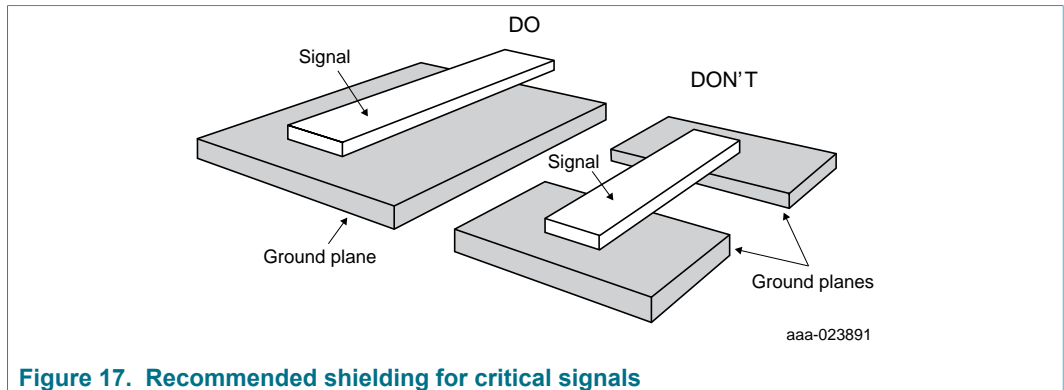

Figure 17. Recommended shielding for critical signals

13.3.5 Switching regulator layout recommendations

- Per design, the switching regulators in PF1510 are designed to operate with only one input bulk capacitor. However, it is recommended to add a high frequency filter input capacitor (C_{IN_hf}), to filter out any noise at the regulator input. This capacitor should be in the range of 100 nF and should be placed right next to or under the IC, closest to the IC pins.
- Make high-current ripple traces low-inductance (short, high W/L ratio).
- Make high-current traces wide or copper islands.

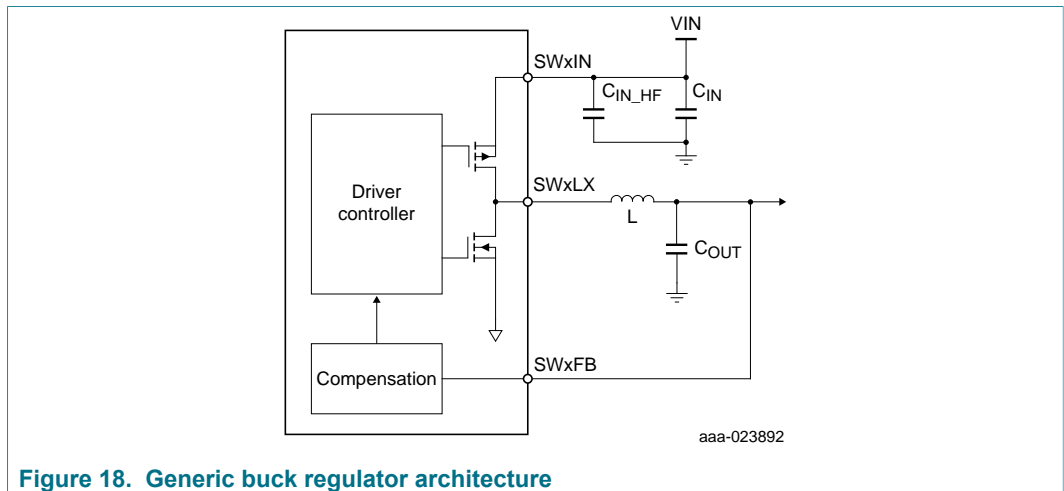

Figure 18. Generic buck regulator architecture

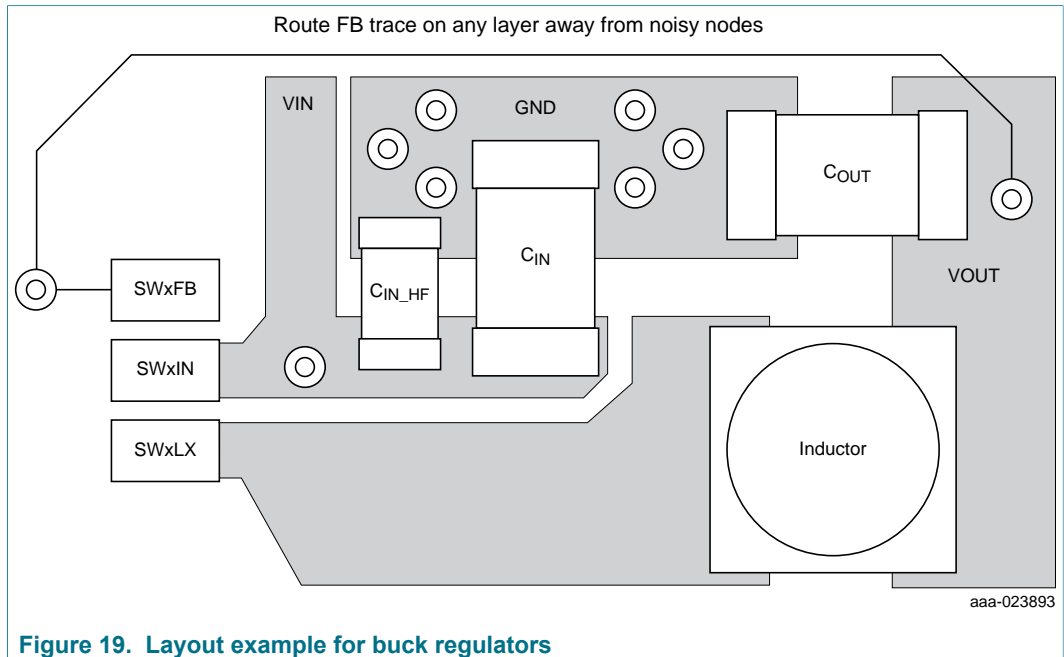

Figure 19. Layout example for buck regulators

13.4 Thermal information

13.4.1 Rating data

The thermal rating data of the packages has been simulated with the results listed in [Table 3](#).

Junction to Ambient Thermal Resistance Nomenclature: the JEDEC specification reserves the symbol $R_{\theta JA}$ or θJA (Theta-JA) strictly for junction-to-ambient thermal resistance on a 1s test board in natural convection environment. $R_{\theta JMA}$ or θJMA (Theta-JMA) is used for both junction-to-ambient on a 2s2p test board in natural convection and for junction-to-ambient with forced convection on both 1s and 2s2p test boards. It is anticipated that the generic name, Theta-JA, continues to be commonly used.

The JEDEC standards can be consulted at <http://www.jedec.org/>.

13.4.2 Estimation of junction temperature

An estimation of the chip junction temperature T_J can be obtained from the equation: $T_J = T_A + (R_{\theta JA} \times P_D)$ with:

T_A = Ambient temperature for the package in °C

$R_{\theta JA}$ = Junction to ambient thermal resistance in °C/W

P_D = Power dissipation in the package in W

The junction to ambient thermal resistance is an industry standard value that provides a quick and easy estimation of thermal performance. Unfortunately, there are two values in common usage: the value determined on a single layer board $R_{\theta JA}$ and the value obtained on a four layer board $R_{\theta JMA}$. Actual application PCBs show a performance close to the simulated four layer board value although this may be somewhat degraded in case of significant power dissipated by other components placed close to the device.

Power management integrated circuit (PMIC) for low power application processors

At a known board temperature, the junction temperature T_J is estimated using the following equation $T_J = T_B + (R_{\theta_{JB}} \times P_D)$ with

T_B = Board temperature at the package perimeter in °C

$R_{\theta_{JB}}$ = Junction to board thermal resistance in °C/W

P_D = Power dissipation in the package in W

14 Packaging information

The PF1510 uses a 40 QFN 5.0 mm x 5.0 mm with exposed pad, case number 98ASA00913D.

14.1 Packaging description

This drawing is available for download at <http://www.nxp.com>. Consult the most recently issued drawing before initiating or completing a design.

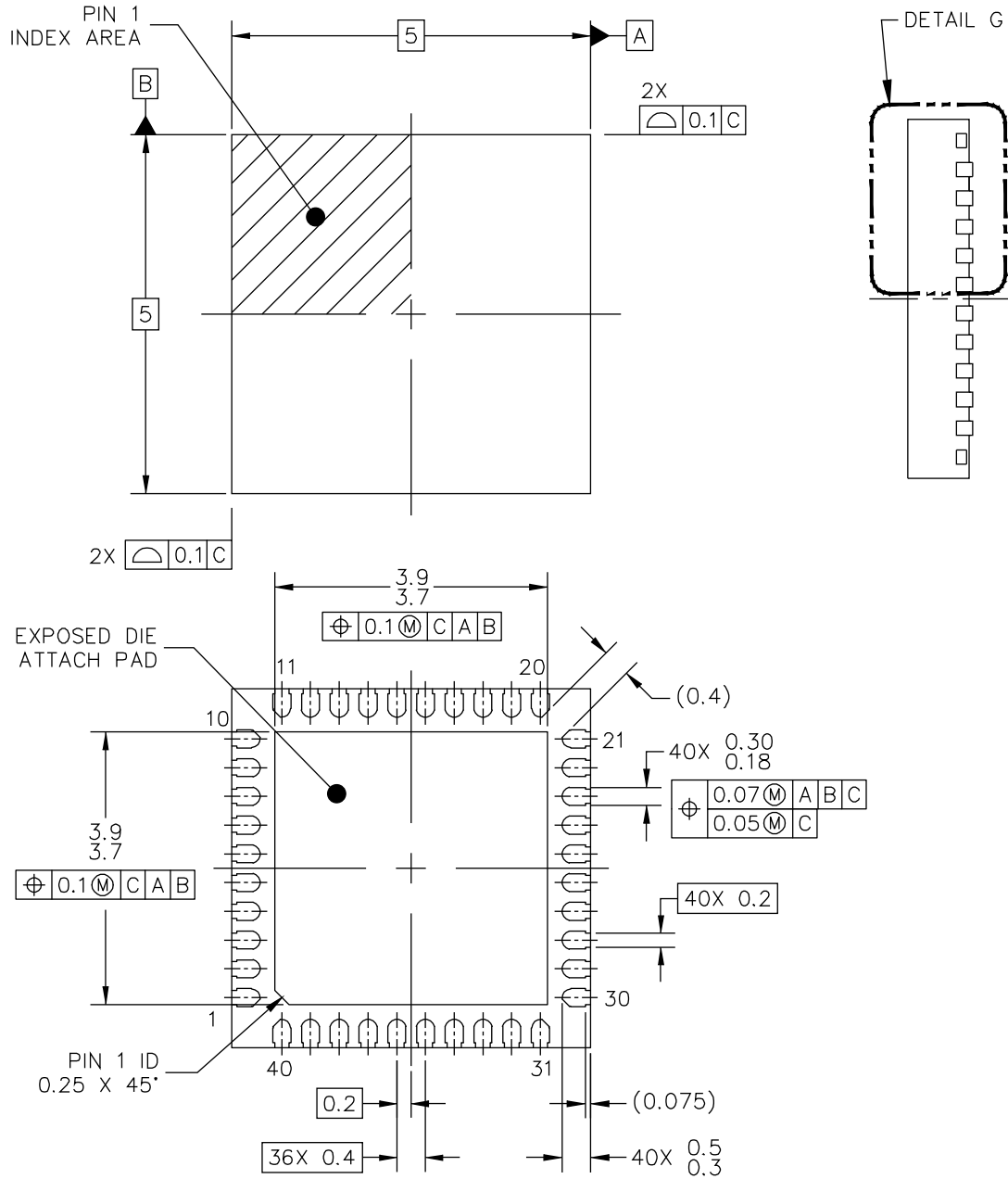

<p>© NXP SEMICONDUCTORS N.V. ALL RIGHTS RESERVED</p>	<p>MECHANICAL OUTLINE</p>	<p>PRINT VERSION NOT TO SCALE</p>
<p>TITLE: QFN, THERMALLY ENHANCED, 5 X 5 X 0.85, 0.4 PITCH, 40 TERMINAL</p>	<p>DOCUMENT NO: 98ASA00913D REV: B STANDARD: NON-JEDEC SOT1369-4 29 MAR 2016</p>	

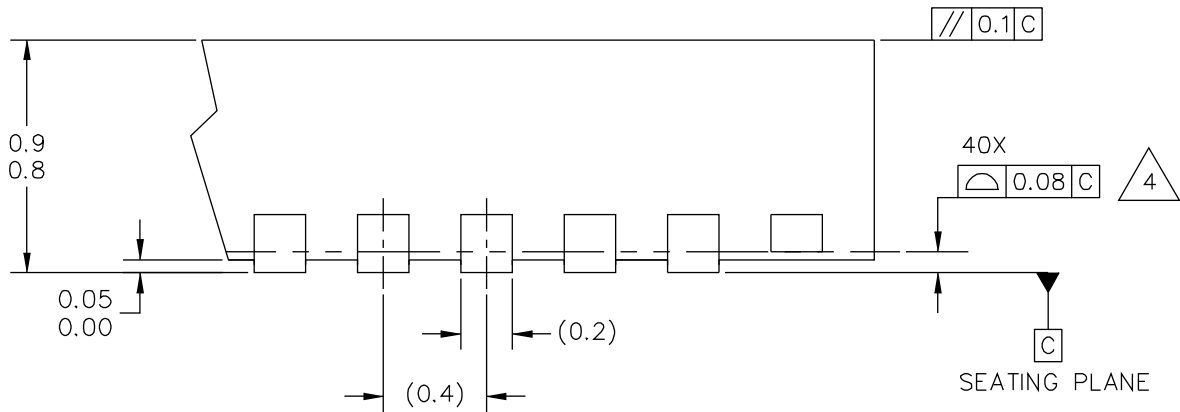

DETAIL G
VIEW ROTATED 90°CW

© NXP SEMICONDUCTORS N.V. ALL RIGHTS RESERVED	MECHANICAL OUTLINE	PRINT VERSION NOT TO SCALE
TITLE: QFN, THERMALLY ENHANCED, 5 X 5 X 0.85, 0.4 PITCH, 40 TERMINAL	DOCUMENT NO: 98ASA00913D	REV: B
	STANDARD: NON-JEDEC	
	SOT1369-4	29 MAR 2016



NOTES:

1. ALL DIMENSIONS ARE IN MILLIMETERS.
2. DIMENSIONING AND TOLERANCING PER ASME Y14.5M-1994.
3. THIS IS A NON-JEDEC REGISTERED PACKAGE.
4.  COPLANARITY APPLIES TO LEADS AND DIE ATTACH FLAG.
5. MIN. METAL GAP SHOULD BE 0.2 MM.

© NXP SEMICONDUCTORS N.V. ALL RIGHTS RESERVED	MECHANICAL OUTLINE	PRINT VERSION NOT TO SCALE	
TITLE: QFN, THERMALLY ENHANCED, 5 X 5 X 0.85, 0.4 PITCH, 40 TERMINAL		DOCUMENT NO: 98ASA00913D	REV: B
		STANDARD: NON-JEDEC	
		SOT1369-4	29 MAR 2016

Figure 20. PF1510 Package dimensions

15 Revision history

Table 131. Revision history

Document ID	Release date	Data sheet status	Change notice	Supersedes
PF1510 v.3.0	20200407	Data sheet: product	CIN 202004001I	PF1510 v.2.0
Modifications	<ul style="list-style-type: none"> • Table 1: added MC32PF1510A0EP and MC34PF1510A0EP (non-programmed parts) 			
PF1510 v.2.0	20190524	Data sheet: product	CIN 201904034I	PF1510 v.1.0
Modifications	<ul style="list-style-type: none"> • Changed data sheet status from advanced information to product • Table 2, pin 38 <ul style="list-style-type: none"> – Changed Recommended connection from "Bypass with 1.0 capacitor to ground" to "Bypass with 2.2 μF capacitor to ground mandatory" – Changed Recommended connection when not used from "Leave floating" to "Bypass with 2.2 μF capacitor to ground mandatory" • Section 7.5 <ul style="list-style-type: none"> – Changed "It derives its power from either V_{SY}S or a coin cell (only if the COIN_CELL bit is set)." to "It derives its power from either V_{SY}S or a coin cell." – Changed "Upon subsequent removal of V_{SY}S, with the coin cell attached and COIN_CELL set, V_{SNVS}..." to "Upon subsequent removal of V_{SY}S, with the coin cell attached, V_{SNVS}..." • Table 45 <ul style="list-style-type: none"> – Changed V_{IL} max from "0.2 * V_{SNVS}" to "0.4" – Changed V_{IH} min from "0.8 * V_{SNVS}" to "1.4" • Added Table 46 • Added Table 47 • Table 49 <ul style="list-style-type: none"> – Changed V_{IL} max from "0.2 * V_{SY}S" to "0.4" – Changed V_{IH} min from "0.8 * V_{SY}S" to "1.4" – Changed "3.6" to "4.8" • Figure 15 <ul style="list-style-type: none"> – Removed step-down from V_{SY}S and V_{SNVS} lines • Figure 16 <ul style="list-style-type: none"> – Terminal 38, changed capacitor value from 1.0 μF to 2.2 μF • Table 125 <ul style="list-style-type: none"> – Changed USBPHYLDO description from "0 — Enabled" to "1 — Enabled" 			
PF1510 v.1.0	20180523	Data sheet: advance information	—	—

16 Legal information

16.1 Data sheet status

Document status ^{[1][2]}	Product status ^[3]	Definition
Objective [short] data sheet	Development	This document contains data from the objective specification for product development.
Preliminary [short] data sheet	Qualification	This document contains data from the preliminary specification.
Product [short] data sheet	Production	This document contains the product specification.

[1] Please consult the most recently issued document before initiating or completing a design.

[2] The term 'short data sheet' is explained in section "Definitions".

[3] The product status of device(s) described in this document may have changed since this document was published and may differ in case of multiple devices. The latest product status information is available on the Internet at URL <http://www.nxp.com>.

16.2 Definitions

Draft — The document is a draft version only. The content is still under internal review and subject to formal approval, which may result in modifications or additions. NXP Semiconductors does not give any representations or warranties as to the accuracy or completeness of information included herein and shall have no liability for the consequences of use of such information.

Short data sheet — A short data sheet is an extract from a full data sheet with the same product type number(s) and title. A short data sheet is intended for quick reference only and should not be relied upon to contain detailed and full information. For detailed and full information see the relevant full data sheet, which is available on request via the local NXP Semiconductors sales office. In case of any inconsistency or conflict with the short data sheet, the full data sheet shall prevail.

Product specification — The information and data provided in a Product data sheet shall define the specification of the product as agreed between NXP Semiconductors and its customer, unless NXP Semiconductors and customer have explicitly agreed otherwise in writing. In no event however, shall an agreement be valid in which the NXP Semiconductors product is deemed to offer functions and qualities beyond those described in the Product data sheet.

16.3 Disclaimers

Limited warranty and liability — Information in this document is believed to be accurate and reliable. However, NXP Semiconductors does not give any representations or warranties, expressed or implied, as to the accuracy or completeness of such information and shall have no liability for the consequences of use of such information. NXP Semiconductors takes no responsibility for the content in this document if provided by an information source outside of NXP Semiconductors. In no event shall NXP Semiconductors be liable for any indirect, incidental, punitive, special or consequential damages (including - without limitation - lost profits, lost savings, business interruption, costs related to the removal or replacement of any products or rework charges) whether or not such damages are based on tort (including negligence), warranty, breach of contract or any other legal theory. Notwithstanding any damages that customer might incur for any reason whatsoever, NXP Semiconductors' aggregate and cumulative liability towards customer for the products described herein shall be limited in accordance with the Terms and conditions of commercial sale of NXP Semiconductors.

Right to make changes — NXP Semiconductors reserves the right to make changes to information published in this document, including without limitation specifications and product descriptions, at any time and without

notice. This document supersedes and replaces all information supplied prior to the publication hereof.

Suitability for use — NXP Semiconductors products are not designed, authorized or warranted to be suitable for use in life support, life-critical or safety-critical systems or equipment, nor in applications where failure or malfunction of an NXP Semiconductors product can reasonably be expected to result in personal injury, death or severe property or environmental damage. NXP Semiconductors and its suppliers accept no liability for inclusion and/or use of NXP Semiconductors products in such equipment or applications and therefore such inclusion and/or use is at the customer's own risk.

Applications — Applications that are described herein for any of these products are for illustrative purposes only. NXP Semiconductors makes no representation or warranty that such applications will be suitable for the specified use without further testing or modification. Customers are responsible for the design and operation of their applications and products using NXP Semiconductors products, and NXP Semiconductors accepts no liability for any assistance with applications or customer product design. It is customer's sole responsibility to determine whether the NXP Semiconductors product is suitable and fit for the customer's applications and products planned, as well as for the planned application and use of customer's third party customer(s). Customers should provide appropriate design and operating safeguards to minimize the risks associated with their applications and products. NXP Semiconductors does not accept any liability related to any default, damage, costs or problem which is based on any weakness or default in the customer's applications or products, or the application or use by customer's third party customer(s). Customer is responsible for doing all necessary testing for the customer's applications and products using NXP Semiconductors products in order to avoid a default of the applications and the products or of the application or use by customer's third party customer(s). NXP does not accept any liability in this respect.

Limiting values — Stress above one or more limiting values (as defined in the Absolute Maximum Ratings System of IEC 60134) will cause permanent damage to the device. Limiting values are stress ratings only and (proper) operation of the device at these or any other conditions above those given in the Recommended operating conditions section (if present) or the Characteristics sections of this document is not warranted. Constant or repeated exposure to limiting values will permanently and irreversibly affect the quality and reliability of the device.

Terms and conditions of commercial sale — NXP Semiconductors products are sold subject to the general terms and conditions of commercial sale, as published at <http://www.nxp.com/profile/terms>, unless otherwise agreed in a valid written individual agreement. In case an individual agreement is concluded only the terms and conditions of the respective agreement shall apply. NXP Semiconductors hereby expressly objects to applying the customer's general terms and conditions with regard to the purchase of NXP Semiconductors products by customer.

Power management integrated circuit (PMIC) for low power application processors

No offer to sell or license — Nothing in this document may be interpreted or construed as an offer to sell products that is open for acceptance or the grant, conveyance or implication of any license under any copyrights, patents or other industrial or intellectual property rights.

Export control — This document as well as the item(s) described herein may be subject to export control regulations. Export might require a prior authorization from competent authorities.

Non-automotive qualified products — Unless this data sheet expressly states that this specific NXP Semiconductors product is automotive qualified, the product is not suitable for automotive use. It is neither qualified nor tested in accordance with automotive testing or application requirements. NXP Semiconductors accepts no liability for inclusion and/or use of non-automotive qualified products in automotive equipment or applications. In the event that customer uses the product for design-in and use in automotive applications to automotive specifications and standards, customer (a) shall use the product without NXP Semiconductors' warranty of the product for such automotive applications, use and specifications, and (b) whenever

customer uses the product for automotive applications beyond NXP Semiconductors' specifications such use shall be solely at customer's own risk, and (c) customer fully indemnifies NXP Semiconductors for any liability, damages or failed product claims resulting from customer design and use of the product for automotive applications beyond NXP Semiconductors' standard warranty and NXP Semiconductors' product specifications.

Translations — A non-English (translated) version of a document is for reference only. The English version shall prevail in case of any discrepancy between the translated and English versions.

16.4 Trademarks

Notice: All referenced brands, product names, service names and trademarks are the property of their respective owners.

NXP — is a trademark of NXP B.V.

Tables

Tab. 1.	Orderable part variations	6	Tab. 55.	Register OTP_FLAVOR - ADDR 0x01	55
Tab. 2.	Pin description	8	Tab. 56.	Register SILICON_REV - ADDR 0x02	55
Tab. 3.	Thermal ratings	9	Tab. 57.	Register INT_CATEGORY - ADDR 0x06	56
Tab. 4.	Maximum ratings	10	Tab. 58.	Register SW_INT_STAT0 - ADDR 0x08	56
Tab. 5.	Front-end LDO	12	Tab. 59.	Register SW_INT_MASK0 - ADDR 0x09	57
Tab. 6.	Input currents	12	Tab. 60.	Register SW_INT_SENSE0 - ADDR 0x0A	57
Tab. 7.	Switch impedances and leakage currents	13	Tab. 61.	Register SW_INT_STAT1 - ADDR 0x0B	58
Tab. 8.	Watchdog timer	13	Tab. 62.	Register SW_INT_MASK1 - ADDR 0x0C	58
Tab. 9.	Internal 2.7 V Regulator (LDO2P7)	13	Tab. 63.	Register SW_INT_SENSE1 - ADDR 0x0D	58
Tab. 10.	USBPHY LDO	13	Tab. 64.	Register SW_INT_STAT2 - ADDR 0x0E	59
Tab. 11.	SW1 and SW2 electrical characteristics	14	Tab. 65.	Register SW_INT_MASK2 - ADDR 0x0F	59
Tab. 12.	SW3 electrical characteristics	16	Tab. 66.	Register SW_INT_SENSE2 - ADDR 0x10	60
Tab. 13.	LDO1 electrical characteristics	17	Tab. 67.	Register LDO_INT_STAT0 - ADDR 0x18	60
Tab. 14.	LDO2 electrical characteristics	18	Tab. 68.	Register LDO_INT_MASK0 - ADDR 0x19	60
Tab. 15.	LDO3 electrical characteristics	19	Tab. 69.	Register LDO_INT_SENSE0 - ADDR 0x1A	61
Tab. 16.	VREFDDR electrical characteristics	20	Tab. 70.	Register TEMP_INT_STAT0 - ADDR 0x20	61
Tab. 17.	VSNVS electrical characteristics	20	Tab. 71.	Register TEMP_INT_MASK0 - ADDR 0x21	61
Tab. 18.	IC level electrical characteristics	21	Tab. 72.	Register TEMP_INT_SENSE0 - ADDR 0x22	62
Tab. 19.	Voltage regulators	22	Tab. 73.	Register ONKEY_INT_STAT0 - ADDR 0x24	62
Tab. 20.	SWx DVS setting selection	24	Tab. 74.	Register ONKEY_INT_MASK0 - ADDR 0x25	63
Tab. 21.	Buck regulator operating modes	25	Tab. 75.	Register ONKEY_INT_SENSE0 - ADDR 0x26	63
Tab. 22.	Buck mode control	26	Tab. 76.	Register MISC_INT_STAT0 - ADDR 0x28	64
Tab. 23.	SW1 and SW2 output voltage setting	27	Tab. 77.	Register MISC_INT_MASK0 - ADDR 0x29	65
Tab. 24.	Acceptable inductance and capacitance values	29	Tab. 78.	Register MISC_INT_SENSE0 - ADDR 0x2A	65
Tab. 25.	Example inductor part numbers	29	Tab. 79.	Register COINCELL_CONTROL - ADDR 0x30	66
Tab. 26.	Example capacitor part numbers	29	Tab. 80.	Register SW1_VOLT - ADDR 0x32	66
Tab. 27.	SW3 buck regulator operating modes	30	Tab. 81.	Register SW1_STBY_VOLT - ADDR 0x33	66
Tab. 28.	SW3 buck mode control	30	Tab. 82.	Register SW1_SLP_VOLT - ADDR 0x34	67
Tab. 29.	SW3 output voltage setting	31	Tab. 83.	Register SW1_CTRL - ADDR 0x35	67
Tab. 30.	Acceptable inductance and capacitance values	32	Tab. 84.	Register SW1_SLP_VOLT - ADDR 0x36	68
Tab. 31.	Example inductor part numbers	32	Tab. 85.	Register SW2_VOLT - ADDR 0x38	68
Tab. 32.	Example capacitor part numbers	32	Tab. 86.	Register SW2_STBY_VOLT - ADDR 0x39	68
Tab. 33.	LDOy output voltage setting	34	Tab. 87.	Register SW2_SLP_VOLT - ADDR 0x3A	69
Tab. 34.	LDOy control bits	35	Tab. 88.	Register SW2_CTRL - ADDR 0x3B	69
Tab. 35.	LDO2 output voltage setting	37	Tab. 89.	Register SW2_CTRL1 - ADDR 0x3C	70
Tab. 36.	LDO2 control bits	38	Tab. 90.	Register SW3_VOLT - ADDR 0x3E	70
Tab. 37.	Front-end regulator register	41	Tab. 91.	Register SW3_STBY_VOLT - ADDR 0x3F	70
Tab. 38.	VSYSTEMIN setting	42	Tab. 92.	Register SW3_SLP_VOLT - ADDR 0x40	71
Tab. 39.	VIN current limit register	42	Tab. 93.	Register SW3_CTRL - ADDR 0x41	71
Tab. 40.	VIN limit settings	42	Tab. 94.	Register SW3_CTRL1 - ADDR 0x42	72
Tab. 41.	PWRON pin OTP configuration options	43	Tab. 95.	Register VSNVS_CTRL - ADDR 0x48	72
Tab. 42.	PWRON pin logic level	43	Tab. 96.	Register VREFDDR_CTRL - ADDR 0x4A	72
Tab. 43.	PWRONBNC settings	44	Tab. 97.	Register LDO1_VOLT - ADDR 0x4C	73
Tab. 44.	Standby pin polarity control	44	Tab. 98.	Register LDO1_CTRL - ADDR 0x4D	73
Tab. 45.	STANDBY pin logic level	44	Tab. 99.	Register LDO2_VOLT - ADDR 0x4F	73
Tab. 46.	RESETBMCU pin logic level	45	Tab. 100.	Register LDO2_CTRL - ADDR 0x50	73
Tab. 47.	INTB pin logic level	45	Tab. 101.	Register LDO3_VOLT - ADDR 0x52	74
Tab. 48.	WDI pin logic level	46	Tab. 102.	Register LDO3_CTRL - ADDR 0x53	74
Tab. 49.	ONKEY pin logic level	46	Tab. 103.	Register PWRCTRL0 - ADDR 0x58	75
Tab. 50.	ONKEYDBNC settings	46	Tab. 104.	Register PWRCTRL1 - ADDR 0x59	75
Tab. 51.	State transition table	50	Tab. 105.	Register PWRCTRL2 - ADDR 0x5A	76
Tab. 52.	A4 startup and power down sequence timing	53	Tab. 106.	Register PWRCTRL3 - ADDR 0x5B	76
Tab. 53.	PF1510 start up configuration	53	Tab. 107.	Register SW1_PWRDN_SEQ - ADDR 0x5F	77
Tab. 54.	Register DEVICE_ID - ADDR 0x00	55			

Tab. 108. Register SW2_PWRDN_SEQ - ADDR 0x60 ...	77	Tab. 119. Register INT_MASK - ADDR 0x02	81
Tab. 109. Register SW2_PWRDN_SEQ - ADDR 0x61 ...	78	Tab. 120. Register INT_OK - ADDR 0x04	82
Tab. 110. Register LDO1_PWRDN_SEQ - ADDR 0x62	78	Tab. 121. Register VIN_SNS - ADDR 0x06	82
Tab. 111. Register LDO2_PWRDN_SEQ - ADDR 0x63	79	Tab. 122. Register FRONT_END_OPER- ADDR 0x09 ...	83
Tab. 112. Register LDO3_PWRDN_SEQ - ADDR 0x64	79	Tab. 123. Register FRONT_END_REG - ADDR 0x0F	83
Tab. 113. Register VREFDDR_PWRDN_SEQ - ADDR 0x65	80	Tab. 124. Register VIN_INLIM_CNFG - ADDR 0x14	83
Tab. 114. Register STATE_INFO - ADDR 0x67	80	Tab. 125. Register USB_PHY_LDO_CNFG - ADDR 0x16	84
Tab. 115. Register I2C_ADDR - ADDR 0x68	80	Tab. 126. Register DBNC_DELAY_TIME - ADDR 0x18	85
Tab. 116. Register RC_16MHZ - ADDR 0x6B	81	Tab. 127. Register VIN2SYS_CNFG - ADDR 0x1B	85
Tab. 117. Register KEY1 - ADDR 0x6B	81	Tab. 128. Register PMIC bitmap	86
Tab. 118. Register INT - ADDR 0x00	81	Tab. 129. Additional register bitmap	91
		Tab. 130. Bill of materials	94
		Tab. 131. Revision history	102

Figures

Fig. 1. Application diagram	3	Fig. 11. VSNVS block diagram	39
Fig. 2. Functional block diagram	4	Fig. 12. Startup sequence	41
Fig. 3. Internal block diagram	5	Fig. 13. I2C sequence	47
Fig. 4. Pinout diagram	7	Fig. 14. PMIC state machine	48
Fig. 5. SWx DVS transitions	24	Fig. 15. A4 startup and power down sequence	53
Fig. 6. SWx DVS and non-DVS selection	25	Fig. 16. Typical schematic	93
Fig. 7. SW3 block diagram	29	Fig. 17. Recommended shielding for critical signals	96
Fig. 8. LDOy Block Diagram	34	Fig. 18. Generic buck regulator architecture	96
Fig. 9. LDO2 block diagram	37	Fig. 19. Layout example for buck regulators	97
Fig. 10. VREFDDR block diagram	39	Fig. 20. PF1510 Package dimensions	99

Contents

1	General description	1	7.4	VREFDDR reference	38
1.1	Features and benefits	1	7.5	VSNVS LDO/Switch	39
1.2	Applications	2	8	Front-end LDO description	40
2	Application diagram	3	8.1	Operating modes and behavioral description ...	41
2.1	Functional block diagram	4	9	Control and interface signals	43
2.2	Internal block diagram	5	9.1	PWRON	43
3	Orderable parts	5	9.2	STANDBY	44
4	Pinning information	7	9.3	RESETMCU	45
4.1	Pinning	7	9.4	INTB	45
4.2	Pin definitions	8	9.5	WDI	46
5	General product characteristics	9	9.6	ONKEY	46
5.1	Thermal characteristics	9	9.7	Control interface I2C block description	47
5.2	Absolute maximum ratings	10	9.7.1	I2C device ID	47
5.3	Electrical characteristics	12	9.7.2	I2C operation	47
5.3.1	Electrical characteristics – Front-end LDO	12	10	PF1510 state machine	48
5.3.2	Electrical characteristics – SW1 and SW2	14	10.1	System ON states	48
5.3.3	Electrical characteristics – SW3	16	10.1.1	Run state	48
5.3.4	Electrical characteristics – LDO1	17	10.1.2	STANDBY state	49
5.3.5	Electrical characteristics – LDO2	18	10.1.3	SLEEP state	49
5.3.6	Electrical characteristics – LDO3	19	10.2	System OFF states	49
5.3.7	Electrical characteristics – VREFDDR	20	10.2.1	REGS_DISABLE	49
5.3.8	Electrical characteristics – VSNVS	20	10.2.2	CORE_OFF	50
5.3.9	Electrical characteristics – IC level bias currents	21	10.3	Turn on events	50
6	Detailed description	22	10.4	Turn off events	50
6.1	Buck regulators	23	10.5	State diagram and transition conditions	50
6.2	SW1 and SW2 detailed description	24	10.6	Regulator power-up sequencer	51
6.2.1	SWx dynamic voltage scaling description	24	10.7	Regulator power-down sequencer	52
6.2.2	SWx DVS and non-DVS operation	25	11	Device start up	52
6.2.3	Regulator control	25	11.1	Startup timing diagram	52
6.2.4	Current limit protection	26	11.2	Device start up configuration	53
6.2.5	Output voltage setting in SWx	26	12	Register map	55
6.2.6	SWx external components	29	12.1	Specific PMIC Registers (Offset is 0x00)	55
6.3	SW3 detailed description	29	12.2	Specific Registers (Offset is 0x80)	81
6.3.1	Regulator control	30	12.3	Register PMIC bitmap	86
6.3.2	Current limit protection	31	12.4	Additional register bitmap	91
6.3.3	Output voltage setting in SW3	31	13	Application details	92
6.3.4	SW3 external components	32	13.1	Example schematic	92
7	Low dropout linear regulators, VREFDDR and VSNVS	33	13.2	Bill of materials	93
7.1	General description	33	13.3	PF1510 layout guidelines	94
7.2	LDO1 and LDO3 detailed description	33	13.3.1	General board recommendations	94
7.2.1	Features summary	33	13.3.2	Component placement	95
7.2.2	LDOy block diagram	34	13.3.3	General routing requirements	95
7.2.3	LDOy external components	34	13.3.4	Parallel routing requirements	95
7.2.4	LDOy output voltage setting	34	13.3.5	Switching regulator layout recommendations ...	96
7.2.5	LDOy low power mode operation	35	13.4	Thermal information	97
7.2.6	LDOy current limit protection	35	13.4.1	Rating data	97
7.2.7	LDOy load switch mode	36	13.4.2	Estimation of junction temperature	97
7.3	LDO2 detailed description	36	14	Packaging information	98
7.3.1	LDO2 features summary	36	14.1	Packaging description	98
7.3.2	LDO2 block diagram	37	15	Revision history	102
7.3.3	LDO2 external components	37	16	Legal information	103
7.3.4	LDO2 output voltage setting	37			
7.3.5	LDO2 Low-power mode operation	38			
7.3.6	LDO2 current limit protection	38			

Please be aware that important notices concerning this document and the product(s) described herein, have been included in section 'Legal information'.

© NXP B.V. 2020.

All rights reserved.

For more information, please visit: <http://www.nxp.com>

For sales office addresses, please send an email to: salesaddresses@nxp.com

Date of release: 7 April 2020
Document identifier: PF1510