

# MC100LVELT22

## 3.3V Dual LVTTTL/LVCMOS to Differential LVPECL Translator

### Description

The MC100LVELT22 is a dual LVTTTL/LVCMOS to differential LVPECL translator. Due to LVPECL (Low Voltage Positive ECL) levels, only +3.3V and ground is required. The small 8-lead package outline with low skew dual gate design makes the MC100LVELT22 ideal for applications which require translation of a clock and/or data signal.

### Features

- 350 ps Typical Propagation Delay
- <100 ps Output-to-Output Skew
- Flow Through Pinouts
- The 100 Series Contains Temperature Compensation
- LVPECL Operating Range:  $V_{CC} = 3.15\text{ V}$  to  $3.45\text{ V}$  with  $GND = 0\text{ V}$
- When Unused TTL Input is left Open, Q Output will Default High
- These are Pb-Free Devices



ON Semiconductor®

[www.onsemi.com](http://www.onsemi.com)

### MARKING DIAGRAMS\*

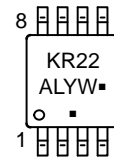
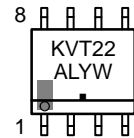

A = Assembly Location  
L = Wafer Lot  
Y = Year  
W = Work Week  
M̄ = Date Code  
▪ = Pb-Free Package

(Note: Microdot may be in either location)

\*For additional marking information, refer to Application Note AND8002/D.

### ORDERING INFORMATION

See detailed ordering and shipping information in the package dimensions section on page 5 of this data sheet.

# MC100LVELT22

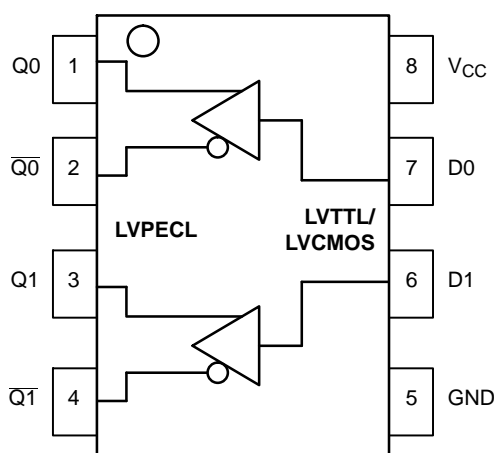

**Table 1. PIN DESCRIPTION**

PIN	FUNCTION
Qn, $\overline{Qn}$	LVPECL Differential Outputs
D0, D1	LVTTTL/LVCMOS Inputs
V <sub>CC</sub>	Positive Supply
GND	Ground

**Figure 1. 8-Lead Pinout (Top View) and Logic Diagram**

**Table 2. ATTRIBUTES**

Characteristics	Value
Internal Input Pulldown Resistor	N/A
Internal Input Pullup Resistor	N/A
ESD Protection	Human Body Model Machine Model
	> 4 kV > 200 V
Moisture Sensitivity, Indefinite Time Out of Drypack (Note 1)	
	SOIC-8 TSSOP-8
	Level 1 Level 3
Flammability Rating	Oxygen Index: 28 to 34
	UL 94 V-0 @ 0.125 in
Transistor Count	164
Meets or exceeds JEDEC Spec EIA/JESD78 IC Latchup Test	

1. For additional information, see Application Note AND8003/D.

**Table 3. MAXIMUM RATINGS**

Symbol	Parameter	Condition 1	Condition 2	Rating	Unit
V <sub>CC</sub>	Positive Power Supply	GND = 0 V		7	V
V <sub>I</sub>	Input Voltage	GND = 0 V	V <sub>I</sub> ≤ V <sub>CC</sub>	7	V
I <sub>out</sub>	Output Current	Continuous Surge		50 100	mA mA
T <sub>A</sub>	Operating Temperature Range			-40 to +85	°C
T <sub>stg</sub>	Storage Temperature Range			-65 to +150	°C
θ <sub>JA</sub>	Thermal Resistance (Junction-to-Ambient)	0 lfpm 500 lfpm	SO-8 SO-8	190 130	°C/W °C/W
θ <sub>JC</sub>	Thermal Resistance (Junction-to-Case)	std bd	SO-8	41 to 44 ± 5%	°C/W
θ <sub>JA</sub>	Thermal Resistance (Junction-to-Ambient)	0 lfpm 500 lfpm	TSSOP-8 TSSOP-8	185 140	°C/W °C/W
θ <sub>JC</sub>	Thermal Resistance (Junction-to-Case)	std bd	TSSOP-8	41 to 44 ± 5%	°C/W
T <sub>sol</sub>	Wave Solder	Pb-Free	<2 to 3 sec @ 260°C	265	°C

Stresses exceeding those listed in the Maximum Ratings table may damage the device. If any of these limits are exceeded, device functionality should not be assumed, damage may occur and reliability may be affected.

2. JEDEC standard multilayer board – 2S2P (2 signal, 2 power)

# MC100LVELT22

**Table 4. LVPECL DC CHARACTERISTICS**  $V_{CC} = 3.3\text{ V}$ ;  $GND = 0.0\text{ V}$  (Note 3)

Symbol	Characteristic	-40°C			25°C			85°C			Unit
		Min	Typ	Max	Min	Typ	Max	Min	Typ	Max	
$I_{CC}$	Power Supply Current			28			28			29	mA
$V_{OH}$	Output HIGH Voltage (Note 4)	2275		2420	2275		2420	2275		2420	mV
$V_{OL}$	Output LOW Voltage (Note 4)	1490		1680	1490		1680	1490		1680	mV

NOTE: Device will meet the specifications after thermal equilibrium has been established when mounted in a test socket or printed circuit board with maintained transverse airflow greater than 500 lfm.

- Output parameters vary 1:1 with  $V_{CC}$ .  $V_{CC}$  can vary  $\pm 0.15\text{ V}$ .
- Outputs are terminated through a 50 ohm resistor to  $V_{CC} - 2\text{ V}$ .

**Table 5. LVTTTL/LVCMOS INPUT DC CHARACTERISTICS**  $V_{CC} = 3.3\text{ V}$ ;  $T_A = -40^\circ\text{C}$  to  $85^\circ\text{C}$  (Note 5)

Symbol	Characteristic	Min	Typ	Max	Unit	Condition
$I_{IH}$	Input HIGH Current			20	$\mu\text{A}$	$V_{IN} = 2.7\text{ V}$
$I_{IHH}$	Input HIGH Current			100	$\mu\text{A}$	$V_{IN} = V_{CC}$
$I_{IL}$	Input LOW Current			-0.2	mA	$V_{IN} = 0.5\text{ V}$
$V_{IK}$	Input Clamp Diode Voltage			-1.2	V	$I_{IN} = -18\text{ mA}$
$V_{IH}$	Input HIGH Voltage	2.0		3.3	V	
$V_{IL}$	Input LOW Voltage	0		0.8	V	

NOTE: Device will meet the specifications after thermal equilibrium has been established when mounted in a test socket or printed circuit board with maintained transverse airflow greater than 500 lfm.

- $V_{CC}$  can vary  $\pm 0.15\text{ V}$ .

**Table 6. AC CHARACTERISTICS**  $V_{CC} = 3.3\text{ V}$ ;  $GND = 0.0\text{ V}$  (Note 6)

Symbol	Characteristic	-40°C			25°C			85°C			Unit
		Min	Typ	Max	Min	Typ	Max	Min	Typ	Max	
$f_{max}$	Maximum Toggle Frequency					350					MHz
$t_{PLH}$	Propagation Delay (Note 7)	200	350	600	200	350	600	200	350	600	ps
$t_{skew}$	Skew Output-to-Output Part-to-Part		30	100 400		30	100 400		30	100 400	ps
$t_{JITTER}$	Random Clock Jitter (RMS)			2.1		1.1	1.9			1.6	ps
$t_{jit(\phi)}$	Additive RMS Phase Jitter $f_c = 50\text{ MHz}$ , Integration Range: 12 kHz to 20 MHz (See Figure 2)					219					fs
$t_r/t_f$	Output Rise/Fall Time (20-80%)	200		550	200		500	200		500	ps

NOTE: Device will meet the specifications after thermal equilibrium has been established when mounted in a test socket or printed circuit board with maintained transverse airflow greater than 500 lfm.

- $V_{CC}$  can vary  $\pm 0.15\text{ V}$ . Outputs are terminated through a 50  $\Omega$  resistor to  $V_{CC} - 2\text{ V}$ .
- Specifications for standard TTL input signal.

## MC100LVELT22

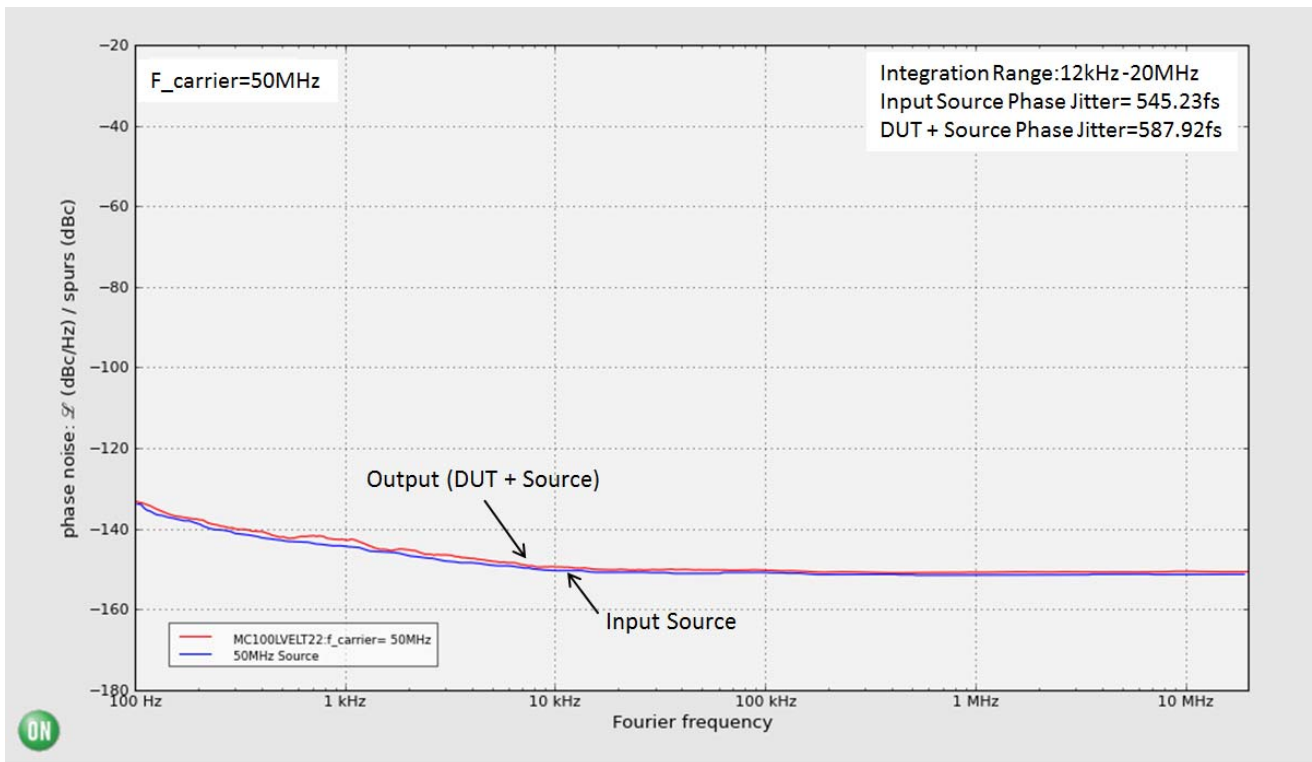

**Figure 2. Typical MC100LVELT22 Phase Noise Plot at  $f_{\text{Carrier}} = 50 \text{ MHz}$ ,  $V_{\text{CC}} = 3.3 \text{ V}$ ,  $25^\circ\text{C}$**

The above phase noise data was captured using Agilent E5052A/B. The data displays the input phase noise and output phase noise used to calculate the additive phase jitter at a specified integration range. The additive RMS phase jitter contributed by the device (integrated between 12 kHz and 20 MHz) is 219 fs. The additive RMS phase jitter performance of the translator is highly dependent on the phase noise of the input source.

To obtain the most precise additive phase noise measurement, it is vital that the source phase noise be

notably lower than that of the DUT. If the phase noise of the source is greater than the noise floor of the device under test, the source noise will dominate the additive phase jitter calculation and lead to an incorrect negative result for the additive phase noise within the integration range. The Figure above is a good example of the MC100LVELT22 source generator phase noise having a significantly lower floor than the DUT and results in an additive phase jitter of 219 fs.

$$\text{Additive RMS phase jitter} = \sqrt{\text{RMS phase jitter of output}^2 - \text{RMS phase jitter of input}^2}$$

$$219 \text{ fs} = \sqrt{587.92 \text{ fs}^2 - 545.23 \text{ fs}^2}$$

Figure 2 was created with measured data from Agilent–E5052B Signal Source Analyzer using ON Semiconductor Phase Noise Explorer web tool. This free application enables an interactive environment for advanced

phase noise and jitter analysis of timing devices and clock tree designs. To see the performance of MC100LVELT22 beyond conditions outlined in this datasheet, please visit the ON Semiconductor [Green Point Design Tools](#) homepage.

## MC100LVELT22

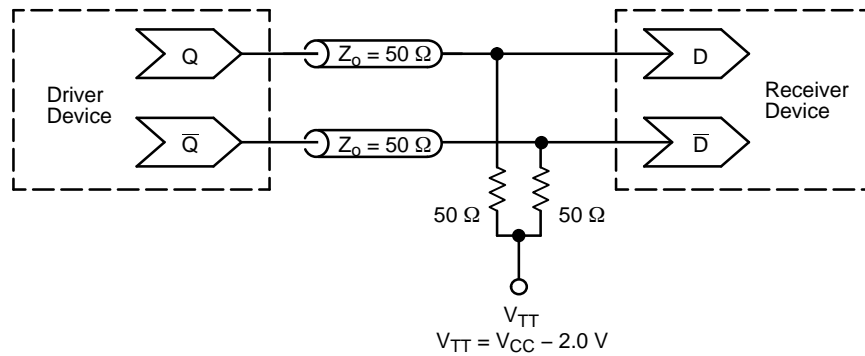

**Figure 3. Typical Termination for Output Driver and Device Evaluation  
(See Application Note AND8020/D – Termination of ECL Logic Devices.)**

### ORDERING INFORMATION

Device	Package	Shipping <sup>†</sup>
MC100LVELT22DG	SOIC-8 (Pb-Free)	98 Units / Rail
MC100LVELT22DR2G	SOIC-8 (Pb-Free)	2500 / Tape & Reel
MC100LVELT22DTG	TSSOP-8 (Pb-Free)	100 Units / Rail
MC100LVELT22DTRG	TSSOP-8 (Pb-Free)	2500 / Tape & Reel

<sup>†</sup>For information on tape and reel specifications, including part orientation and tape sizes, please refer to our Tape and Reel Packaging Specifications Brochure, BRD8011/D.

### Resource Reference of Application Notes

- AN1405/D** – ECL Clock Distribution Techniques
- AN1406/D** – Designing with PECL (ECL at +5.0 V)
- AN1503/D** – ECLinPS™ I/O SPICE Modeling Kit
- AN1504/D** – Metastability and the ECLinPS Family
- AN1568/D** – Interfacing Between LVDS and ECL
- AN1672/D** – The ECL Translator Guide
- AND8001/D** – Odd Number Counters Design
- AND8002/D** – Marking and Date Codes
- AND8020/D** – Termination of ECL Logic Devices
- AND8066/D** – Interfacing with ECLinPS
- AND8090/D** – AC Characteristics of ECL Devices

# MC100LVELT2

## PACKAGE DIMENSIONS

SOIC-8 NB  
CASE 751-07  
ISSUE AK

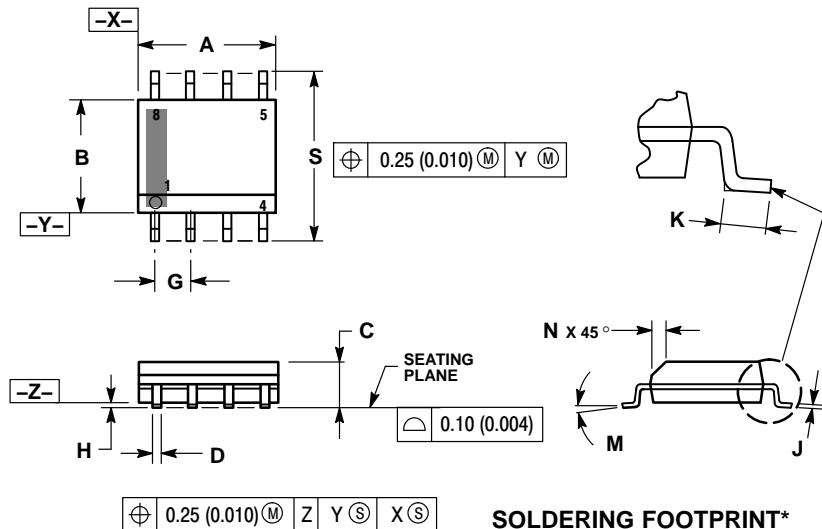

- NOTES:
1. DIMENSIONING AND TOLERANCING PER ANSI Y14.5M, 1982.
  2. CONTROLLING DIMENSION: MILLIMETER.
  3. DIMENSION A AND B DO NOT INCLUDE MOLD PROTRUSION.
  4. MAXIMUM MOLD PROTRUSION 0.15 (0.006) PER SIDE.
  5. DIMENSION D DOES NOT INCLUDE DAMBAR PROTRUSION. ALLOWABLE DAMBAR PROTRUSION SHALL BE 0.127 (0.005) TOTAL IN EXCESS OF THE D DIMENSION AT MAXIMUM MATERIAL CONDITION.
  6. 751-01 THRU 751-06 ARE OBSOLETE. NEW STANDARD IS 751-07.

DIM	MILLIMETERS		INCHES	
	MIN	MAX	MIN	MAX
A	4.80	5.00	0.189	0.197
B	3.80	4.00	0.150	0.157
C	1.35	1.75	0.053	0.069
D	0.33	0.51	0.013	0.020
G	1.27 BSC		0.050 BSC	
H	0.10	0.25	0.004	0.010
J	0.19	0.25	0.007	0.010
K	0.40	1.27	0.016	0.050
M	0°	8°	0°	8°
N	0.25	0.50	0.010	0.020
S	5.80	6.20	0.228	0.244

### SOLDERING FOOTPRINT\*

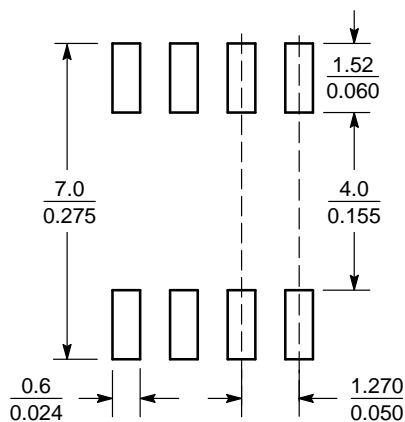

SCALE 6:1  $\left(\frac{\text{mm}}{\text{inches}}\right)$

\*For additional information on our Pb-Free strategy and soldering details, please download the ON Semiconductor Soldering and Mounting Techniques Reference Manual, SOLDERRM/D.

# MC100LVELT22

## PACKAGE DIMENSIONS

TSSOP-8  
DT SUFFIX  
CASE 948R-02  
ISSUE A

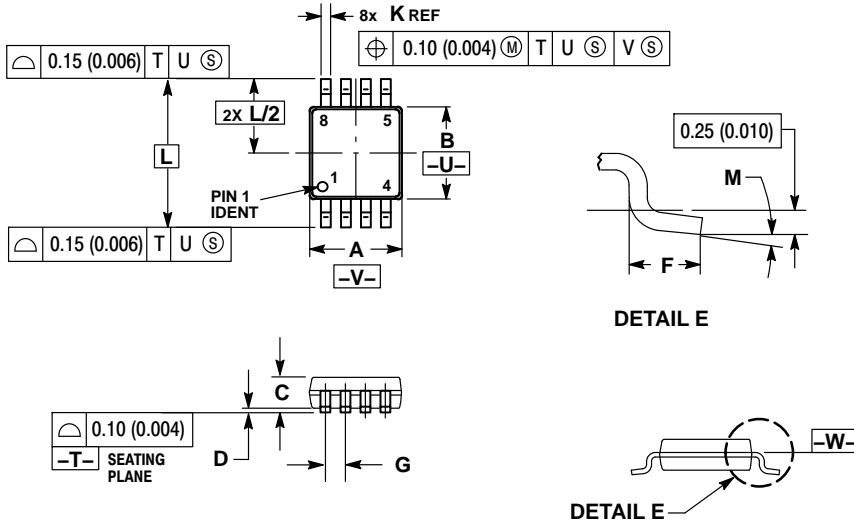

- NOTES:
1. DIMENSIONING AND TOLERANCING PER ANSI Y14.5M, 1982.
  2. CONTROLLING DIMENSION: MILLIMETER.
  3. DIMENSION A DOES NOT INCLUDE MOLD FLASH. PROTRUSIONS OR GATE BURRS. MOLD FLASH OR GATE BURRS SHALL NOT EXCEED 0.15 (0.006) PER SIDE.
  4. DIMENSION B DOES NOT INCLUDE INTERLEAD FLASH OR PROTRUSION. INTERLEAD FLASH OR PROTRUSION SHALL NOT EXCEED 0.25 (0.010) PER SIDE.
  5. TERMINAL NUMBERS ARE SHOWN FOR REFERENCE ONLY.
  6. DIMENSION A AND B ARE TO BE DETERMINED AT DATUM PLANE -V-.

DIM	MILLIMETERS		INCHES	
	MIN	MAX	MIN	MAX
A	2.90	3.10	0.114	0.122
B	2.90	3.10	0.114	0.122
C	0.80	1.10	0.031	0.043
D	0.05	0.15	0.002	0.006
F	0.40	0.70	0.016	0.028
G	0.65 BSC		0.026 BSC	
K	0.25	0.40	0.010	0.016
L	4.90 BSC		0.193 BSC	
M	0°	6°	0°	6°

ECLinPS is a trademark of Semiconductor Components Industries, LLC (SCILLC).

ON Semiconductor and are trademarks of Semiconductor Components Industries, LLC dba ON Semiconductor or its subsidiaries in the United States and/or other countries. ON Semiconductor owns the rights to a number of patents, trademarks, copyrights, trade secrets, and other intellectual property. A listing of ON Semiconductor's product/patent coverage may be accessed at [www.onsemi.com/site/pdf/Patent-Marking.pdf](http://www.onsemi.com/site/pdf/Patent-Marking.pdf). ON Semiconductor reserves the right to make changes without further notice to any products herein. ON Semiconductor makes no warranty, representation or guarantee regarding the suitability of its products for any particular purpose, nor does ON Semiconductor assume any liability arising out of the application or use of any product or circuit, and specifically disclaims any and all liability, including without limitation special, consequential or incidental damages. Buyer is responsible for its products and applications using ON Semiconductor products, including compliance with all laws, regulations and safety requirements or standards, regardless of any support or applications information provided by ON Semiconductor. "Typical" parameters which may be provided in ON Semiconductor data sheets and/or specifications can and do vary in different applications and actual performance may vary over time. All operating parameters, including "Typicals" must be validated for each customer application by customer's technical experts. ON Semiconductor does not convey any license under its patent rights nor the rights of others. ON Semiconductor products are not designed, intended, or authorized for use as a critical component in life support systems or any FDA Class 3 medical devices or medical devices with a same or similar classification in a foreign jurisdiction or any devices intended for implantation in the human body. Should Buyer purchase or use ON Semiconductor products for any such unintended or unauthorized application, Buyer shall indemnify and hold ON Semiconductor and its officers, employees, subsidiaries, affiliates, and distributors harmless against all claims, costs, damages, and expenses, and reasonable attorney fees arising out of, directly or indirectly, any claim of personal injury or death associated with such unintended or unauthorized use, even if such claim alleges that ON Semiconductor was negligent regarding the design or manufacture of the part. ON Semiconductor is an Equal Opportunity/Affirmative Action Employer. This literature is subject to all applicable copyright laws and is not for resale in any manner.

### PUBLICATION ORDERING INFORMATION

**LITERATURE FULFILLMENT:**  
Literature Distribution Center for ON Semiconductor  
P.O. Box 5163, Denver, Colorado 80217 USA  
**Phone:** 303-675-2175 or 800-344-3860 Toll Free USA/Canada  
**Fax:** 303-675-2176 or 800-344-3867 Toll Free USA/Canada  
**Email:** [orderlit@onsemi.com](mailto:orderlit@onsemi.com)

**N. American Technical Support:** 800-282-9855 Toll Free  
USA/Canada  
**Europe, Middle East and Africa Technical Support:**  
Phone: 421 33 790 2910  
**Japan Customer Focus Center**  
Phone: 81-3-5817-1050

**ON Semiconductor Website:** [www.onsemi.com](http://www.onsemi.com)  
**Order Literature:** <http://www.onsemi.com/orderlit>

For additional information, please contact your local Sales Representative