

Differential Video Interface Chipset

General Description

The MAX9546/MAX9547 differential interface chipset converts single-ended voltages to differential voltages for transport and then converts back to single-ended voltages. These devices eliminate costly, bulky, single-ended coaxial cables with inexpensive, readily available, differential shielded (ScTP) or unshielded (UTP) twisted pairs. The fault detection of the MAX9546 and loss-of-signal detection of the MAX9547 allow proactive and speedy diagnosis, such as identifying failures in the manufacturing stage and troubleshooting equipment at repair facilities. The MAX9546/MAX9547 are low-cost, convenient solutions for transporting CVBS/FBAS analog video signals (PAL or NTSC) through hostile environments.

The MAX9546 driver converts the single-ended input into a differential output with a 6dB fixed gain to drive a back-terminated, DC-coupled differential video output to unity gain. This DC connection allows the detection of a short-circuit condition at the differential outputs. The $\overline{\text{FAULT}}$ output indicates a short-circuit condition including a short to a high battery condition ($V_{\text{BAT}} = +16\text{V}$) or ground. The MAX9546 specifies the common-mode balance (CMB) of the differential outputs.

The MAX9547 receiver converts the differential signal from the MAX9546 into a single-ended signal. Like the MAX9546 output, the MAX9547 input survives a short to a high battery condition or ground. The MAX9547 receiver loss-of-signal output ($\overline{\text{LOS}}$) operates by detecting the H-Sync and thus can support both monochrome and color video signals. The MAX9547 gain is set with an external impedance between ZT+ and ZT-.

The MAX9546/MAX9547 operate from a 7.5V to 10V single supply. Both devices include $\pm 15\text{kV}$ ESD Human Body Model (HBM) protection. The MAX9546/MAX9547 are offered in a thermally enhanced 8-pin SO package and specified over the -40°C to $+85^{\circ}\text{C}$ extended temperature range.

Applications

Automotive Video
 Car Navigation
 In-Car Entertainment
 Collision Avoidance/Rearview Cameras
 Security/CCTV Video
 Avionics/In-Flight Entertainment

Features

- ◆ Fault Detection (MAX9546)
- ◆ Loss-of-Signal Detection (MAX9547)
- ◆ Tolerate $\pm 2\text{V}$ Ground-Level Shift between Source and Load
- ◆ Specifies Common-Mode Balance (MAX9546)
- ◆ $\pm 15\text{kV}$ ESD Protection (Human Body Model)
- ◆ $\pm 8\text{kV}$ —IEC 1000-4-2 Contact Discharge
- ◆ $\pm 15\text{kV}$ —IEC 1000-4-2 Air-Gap Discharge
- ◆ Preset 6dB Gain (MAX9546)
- ◆ Variable Receiver Gain (MAX9547)
- ◆ 7.5V to 10V Single-Supply Operation

Ordering Information

PART	PIN-PACKAGE	PKG CODE	DESCRIPTION
MAX9546ESA+	8 SO-EP*	S8E-14	Driver
MAX9547ESA+	8 SO-EP*	S8E-14	Receiver

Note: These devices are specified for -40°C to $+85^{\circ}\text{C}$ temperature range.

+Denotes lead-free package.

*EP = Exposed paddle.

Pin Configuration appears at end of data sheet.

Typical Operating Circuit

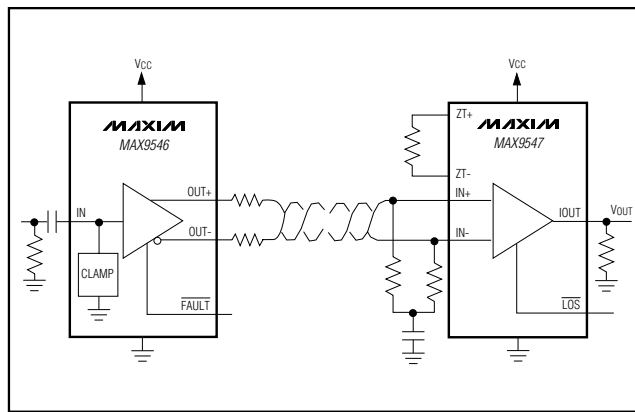

Differential Video Interface Chipset

ABSOLUTE MAXIMUM RATINGS

(Voltages are referenced GND.)

V _{CC} to GND	-0.3V to +11V
IN and $\overline{\text{FAULT}}$ (MAX9546)	-0.3V to (V _{CC} + 0.3V)
OUT+, OUT- (MAX9546) (Note 1)	-2V to +16V
$\overline{\text{FAULT}}$ Short-Circuit Duration to	
V _{CC} or GND (MAX9546)	Continuous
IN+, IN- (MAX9547) (Note 1)	-2V to +16V
I _{OUT} , $\overline{\text{LOS}}$, ZT+, ZT- (MAX9547)	-0.3V to (V _{CC} + 0.3V)
Differential Input Voltage (V _{IN+} - V _{IN-}) (MAX9547)	+5V

I_{OUT}, $\overline{\text{LOS}}$ Short-Circuit Duration to

V _{CC} or GND (MAX9547)	Continuous
Continuous Power Dissipation (T _A = +70°C)	
8-Pin SO (derate 19.2mW/°C above +70°C)	1538mW
Operating Temperature Range	-40°C to +85°C
Junction Temperature	+150°C
Storage Temperature Range	-65°C to +150°C
Lead Temperature (soldering, 10s)	+300°C

Note 1: The Absolute Maximum Ratings of OUT+/OUT- for the MAX9546 and IN+/IN- for the MAX9547 are based on a single-fault condition, i.e. only one output of MAX9546 (or both outputs together) is shorted to the battery, V_{CC} or GND. The devices will not survive a double-fault condition, i.e. OUT+ and OUT- shorted to different supplies.

Stresses beyond those listed under "Absolute Maximum Ratings" may cause permanent damage to the device. These are stress ratings only, and functional operation of the device at these or any other conditions beyond those indicated in the operational sections of the specifications is not implied. Exposure to absolute maximum rating conditions for extended periods may affect device reliability.

DC ELECTRICAL CHARACTERISTICS—MAX9546

(V_{CC} = +8.5V, R_L = 220Ω between OUT+ and OUT-, T_A = -40°C to +85°C. Typical values are at T_A = +25°C, unless otherwise noted.) (Note 2)

PARAMETER	SYMBOL	CONDITIONS	MIN	TYP	MAX	UNITS
Supply Voltage Range	V _{CC}	Guaranteed by PSRR	7.5	8.5	10.0	V
Quiescent Supply Current	I _{CC}	No load		64	112	mA
Voltage Gain	A _V	V _{IN} = 1.2V _{P-P} (Note 3)	1.8	2	2.2	V/V
Input-Voltage Swing	V _{IN}	Guaranteed by A _V			1.2	V _{P-P}
Input Clamp Voltage	V _{CLMP}	(Note 4)		3.46		V
Input Clamp Current	I _{CLMP}	(Note 4)		7	13	μA
Input Resistance	R _{IN}	(Notes 4, 5)		500		kΩ
Output Common-Mode Voltage	V _{COM}		3.0	3.25	3.4	V
Output Impedance	R _{OUT}			0.1		Ω
Output Fault Current	I _{F(OUT)}	OUT+ and/or OUT- to +16V		9		mA
		OUT+ and/or OUT- to + (V _{CC} - 2V)		2		
		OUT+ and/or OUT- to +2V		4		
		OUT+ and/or OUT- to -2V		7		
		OUT+ and/or OUT- to +16V, V _{CC} unconnected		6		
		OUT+ or OUT- to -2V, V _{CC} unconnected		24		
Power-Supply Rejection Ratio	PSRR	V _{CC} from 7.5V to 10V (Note 6)	Differential mode	45	62	dB
			Common mode	46	52	
$\overline{\text{FAULT}}$ Output Logic Level		V _{OL} , I _{SINK} = 1.6mA (Note 7)			0.4	V
$\overline{\text{FAULT}}$ Output Leakage Current				0.01		μA

Differential Video Interface Chipset

MAX9546/MAX9547

AC ELECTRICAL CHARACTERISTICS—MAX9546

($V_{CC} = +8.5V$, $R_L = 220\Omega$ across $OUT+$ and $OUT-$, $T_A = -40^\circ C$ to $+85^\circ C$. Typical values are at $T_A = +25^\circ C$, unless otherwise noted.) (Note 2)

PARAMETER	SYMBOL	CONDITIONS	MIN	TYP	MAX	UNITS
Large-Signal Bandwidth		$V_{IN} = 1V_{P-P}$, -3dB		18		MHz
Large-Signal Flatness		$V_{IN} = 1V_{P-P}$, $\pm 0.5dB$		15		MHz
Slew Rate	SR	$OUT+ - OUT-$		70		V/ μs
Settling Time (0.1%)	$t_{SETTLING}$	$V_{IN} = 1V_{P-P}$		400		ns
Power-Supply Rejection Ratio	PSRR	$f = 100kHz$, 100mV _{P-P} ripple		63		dB
Common-Mode Balance (Note 8)	CMB	$f = 100kHz$		50		dB
		$f = 3.58MHz$		30		
Drop		Guaranteed by input current		1		%

DC ELECTRICAL CHARACTERISTICS—MAX9547

($V_{CC} = +8.5V$, $GND = 0V$, $R_L = 75\Omega$, $Z_{ZT} = 75\Omega$, $T_A = -40^\circ C$ to $+85^\circ C$. Typical values are at $T_A = +25^\circ C$.) (Note 2)

PARAMETER	SYMBOL	CONDITIONS	MIN	TYP	MAX	UNITS
Supply Voltage Range	V_{CC}	Guaranteed by PSRR	7.5	8.5	10.0	V
Supply Current	I_{CC}			70	110	mA
Differential Input Voltage Range $I_{IN+} - I_{IN-}$	$V_{IN(P-P)}$	Guaranteed by CMRR (Note 9)			1.2	V _{P-P}
Common-Mode Input Voltage Range	V_{COM}	Guaranteed by CMRR (Note 9)	1.0		5.4	V
Input Current	I_{IN}			6	30	μA
Input Offset Current	ΔI_{IN}			1	4.2	μA
Input Resistance	R_{IN}	Differential		80		k Ω
Voltage Gain	A_V	$V_{IN(P-P)} = 1.2V$, defined as $I_{OUT} \times (R_L / V_{IN})$	0.90	1	1.15	V/V
Output Voltage	V_{OB}	$I_{N+} = I_{N-} = 3.2V$		1		V
Output Voltage Swing	V_{OUT}				1.2	V _{P-P}
Maximum Output Current	I_{OUT}	$V_{IN} = 1V$, $Z_{ZT} = 0$		21		mA
Power-Supply Rejection Ratio	PSRR	V_{CC} from 7.5V to 10V	26	34		dB
Common-Mode Rejection Ratio	CMRR	$1V \leq V_{COM} \leq 5.4V$	42	54		dB
		$2V \leq V_{COM} \leq 4.4V$	46	70		
LOS Logic Level		V_{OL} , $I_{SINK} = 1.6mA$ (Note 10)			0.4	V
LOS Leakage Current				0.01		μA
Input Fault Current	I_F	I_{N+} and/or I_{N-} to +16V, $R_{T1} + R_{T2} = 110\Omega$		50		mA
		I_{N+} and/or I_{N-} to -2V, $R_{T1} + R_{T2} = 110\Omega$		10		
		I_{N+} and/or I_{N-} to +16V, V_{CC} unconnected, $R_{T1} + R_{T2} = 110\Omega$		72		
		I_{N+} and/or I_{N-} to -2V, V_{CC} unconnected, $R_{T1} + R_{T2} = 110\Omega$		10		

Differential Video Interface Chipset

AC ELECTRICAL CHARACTERISTICS—MAX9547

($V_{CC} = +8.5V$, $GND = 0V$, $R_L = 75\Omega$, $Z_{IT} = 75\Omega$, $C_L = 50pF$, $T_A = -40^\circ C$ to $+85^\circ C$, Typical values are at $T_A = +25^\circ C$.) (Note 2)

PARAMETER	SYMBOL	CONDITIONS	MIN	TYP	MAX	UNITS
Large-Signal Bandwidth		$V_{IN} = 1V_{P-P}$, -3dB		20		MHz
Large-Signal Flatness		$V_{IN} = 1V_{P-P}$, $\pm 0.5dB$		15		MHz
Slew Rate	SR			50		V/ μs
Settling Time (0.1%)	t _{SETTLING}			400		ns
Power-Supply Rejection Ratio	PSRR	f = 100kHz, 100mV _{P-P} ripple		30		dB
Common-Mode Rejection Ratio	CMRR	f = 100kHz, 100mV _{P-P} ripple		53		dB
LOS Timeout Period	t _{LOS}			760		μs

AC ELECTRICAL CHARACTERISTICS—MAX9546 Driving MAX9547

($V_{CC} = +8.5V$, $R_L = 220\Omega$ across $OUT+$ and $OUT-$, $R_L = 75\Omega$ (MAX9547), $Z_{IT} = 75\Omega$, $T_A = -40^\circ C$ to $+85^\circ C$. Typical values are at $T_A = +25^\circ C$, unless otherwise noted.) (Note 2)

PARAMETER	SYMBOL	CONDITIONS	MIN	TYP	MAX	UNITS
Differential Gain	DG			3.8		%
Differential Phase	DP			0.6		degrees
Signal-to-Noise Ratio	SNR	5MHz lowpass, 100kHz highpass, $V_{IN} = 1V_{P-P}$		80		dB
2T Pulse-to-Bar Rating		2T = 250ns, bar time is 18 μs , the beginning 3.5% and the ending 3.5% of the bar time is ignored		0.2		%
2T Pulse Response		2T = 250ns		0.25		%
Group Delay	D/dt	At 3.58MHz		10		ns

Note 2: All devices are 100% production tested at $T_A = +25^\circ C$. All temperature limits are guaranteed by design.

Note 3: Defined as differential output to single-ended input.

Note 4: Input is AC-coupled.

Note 5: The RC time constant (3Hz) formed by the source resistance (R_S) and coupling capacitor (C_{IN}) is usually used for lead compensation of the active clamp. The source resistance is 400 Ω max. The clamp should remain stable in this condition.

Note 6: Differential mode is defined as $(OUT+ - OUT-)$. Common mode is defined as $\frac{OUT+ + OUT-}{2}$.

Note 7: A fault is when the outputs both sink and source current and the amount of extra current sink or source is greater than 3mA.

Note 8: Common-mode balance is defined as $20\log((OUT+ - OUT-) / (OUT+ + OUT-))$.

Note 9: Ground between MAX9546 and MAX9547 can be a $\pm 2V$ difference.

Note 10: A loss-of-signal is when the input video signal of the MAX9547 does not change (cross 100mV level from sync tip) for 10 video lines.

Differential Video Interface Chipset

Typical Operating Characteristics

($V_{CC} = +8.5V$, $R_L = 220\Omega$ between OUT+ and OUT-, $R_L = 75\Omega$ (MAX9547), $Z_{T} = 75\Omega$, $T_A = +25^\circ C$, unless otherwise noted.)

MAX9546/MAX9547

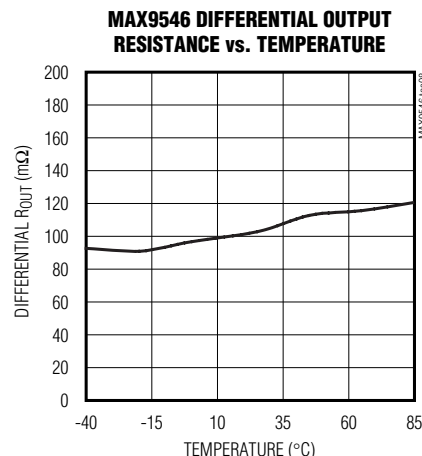
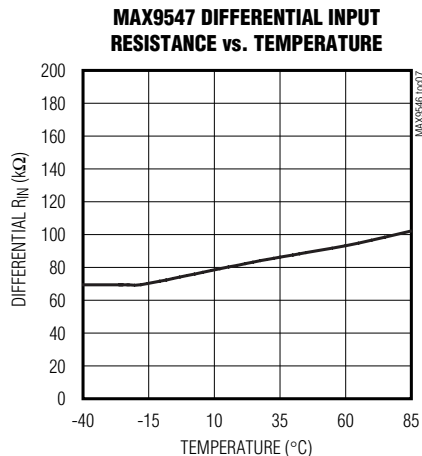
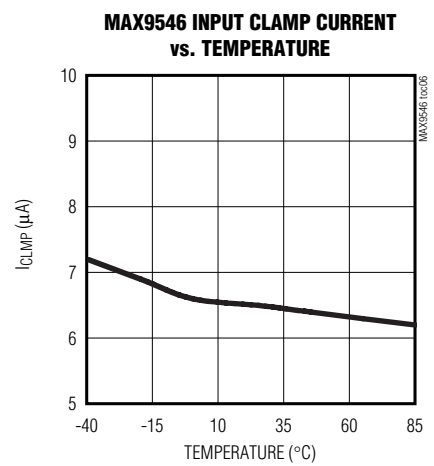
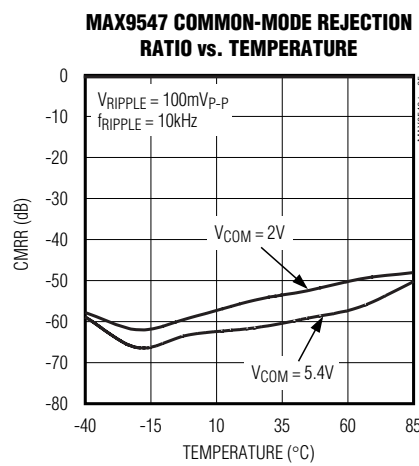
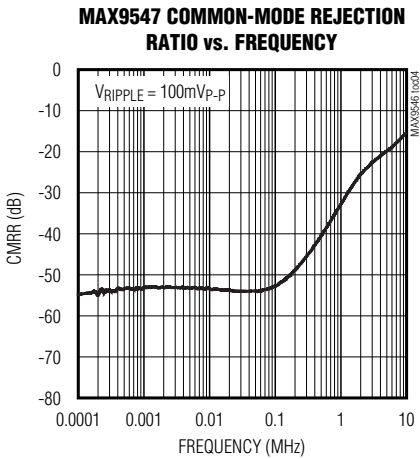
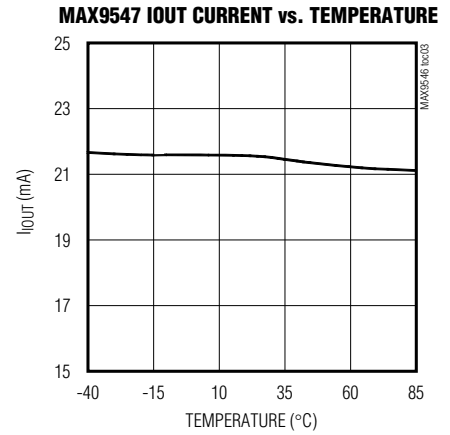
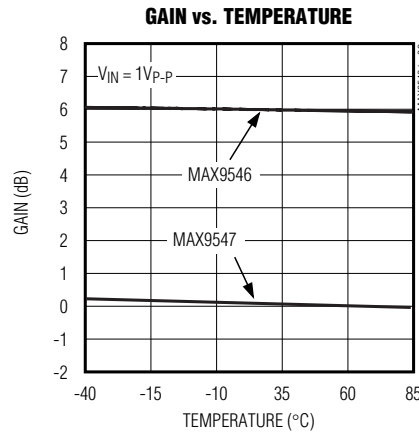
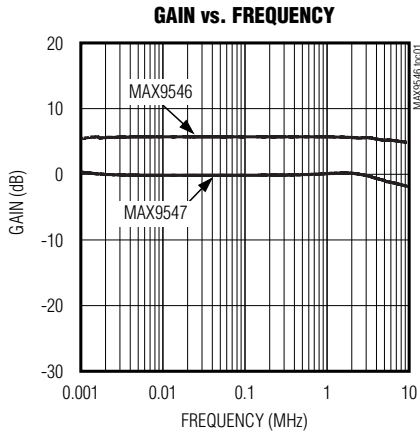

Differential Video Interface Chipset

Typical Operating Characteristics (continued)

($V_{CC} = +8.5V$, $R_L = 220\Omega$ between OUT+ and OUT-, $R_L = 75\Omega$ (MAX9547), $Z_{T} = 75\Omega$, $T_A = +25^\circ C$, unless otherwise noted.)

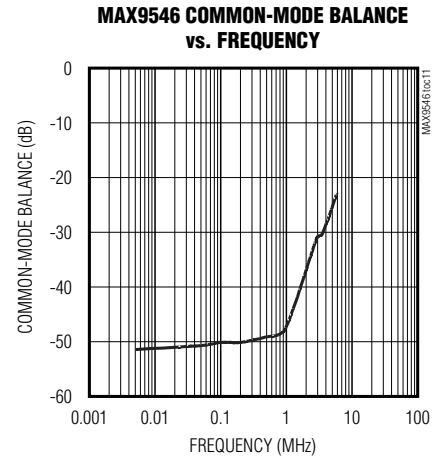
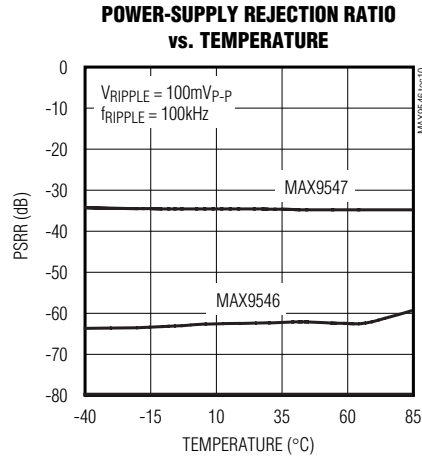
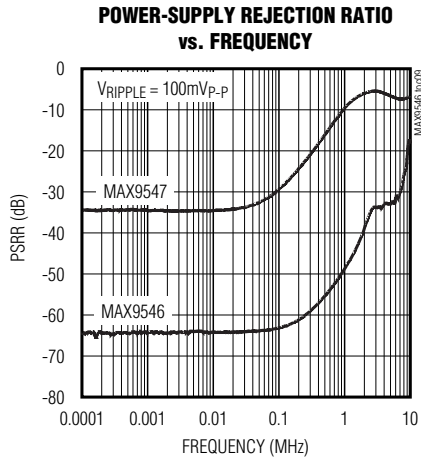

DIFFERENTIAL GAIN (MAX9546 DRIVING MAX9547)

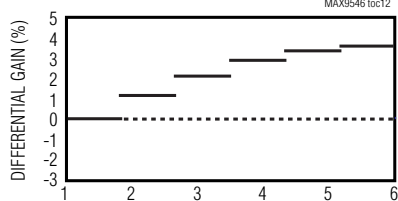

DIFFERENTIAL PHASE (MAX9546 DRIVING MAX9547)

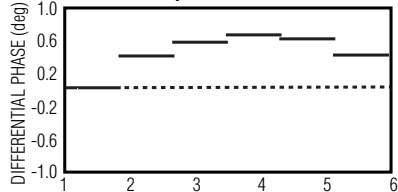

GROUP DELAY vs. FREQUENCY (MAX9546 DRIVING MAX9547)

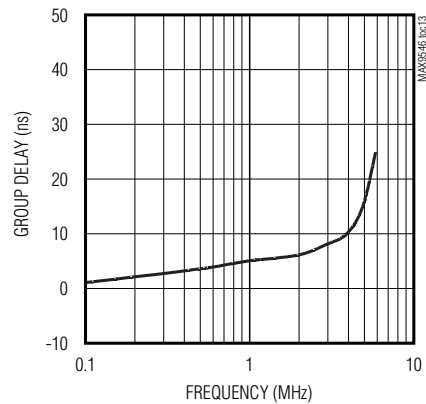

OUTPUT RESPONSE TO NTC-7 VIDEO TEST SIGNAL (MAX9546 DRIVING MAX9547)

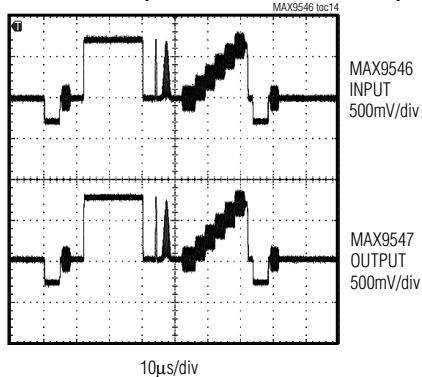

SIGNAL-TO-NOISE RATIO vs. FREQUENCY (MAX9546 DRIVING MAX9547)

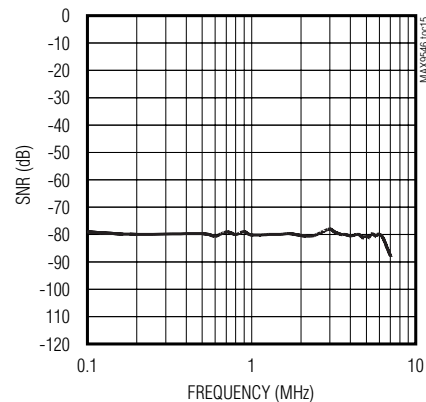

Differential Video Interface Chipset

Pin Description (MAX9546)

PIN	NAME	FUNCTION
1, 8	V _{CC}	Power Supply. Connect together and bypass with a 0.1μF in parallel with a 4.7μF capacitor to GND.
2	IN	Video Input
3	$\overline{\text{FAULT}}$	Fault Indicator. Active-low, open-drain output. $\overline{\text{FAULT}}$ = low when fault is detected at the output. $\overline{\text{FAULT}}$ = high when no fault is detected at the output.
4, 5	GND	Ground
6	OUT-	Negative Differential Output
7	OUT+	Positive Differential Output
EP	EP	Exposed Paddle. Connect to GND.

Pin Description (MAX9547)

PIN	NAME	FUNCTION
1	IN+	Positive Differential Input
2	ZT+	Positive Transconductance Terminal
3	ZT-	Negative Transconductance Terminal
4	IN-	Negative Differential Input
5	GND	Ground
6	$\overline{\text{LOS}}$	Loss-of-Signal Indicator. Active-low, open-drain output. $\overline{\text{LOS}}$ = low when no signal is detected at the input. $\overline{\text{LOS}}$ = high when signal is present at the input.
7	IOUT	Current Output
8	V _{CC}	Power Supply. Bypass with a 0.1μF capacitor in parallel with a 4.7μF capacitor to GND.
EP	EP	Exposed Paddle. Connect to GND.

Detailed Description

The MAX9546/MAX9547 differential interface chipset converts single-ended voltages to differential voltages for transport and then converts back to single-ended voltages. The chipset is optimized for transporting CVBS/FBAS analog video signals (PAL or NTSC) through hostile automotive environments. The MAX9546 driver includes a fault output (FAULT) that indicates shorted transmission cables. The MAX9547 receiver loss-of-signal output ($\overline{\text{LOS}}$) indicates an absence of input signal.

The MAX9546/MAX9547 operate from a 7.5V to 10V single supply. The differential interface is immune to short-circuit conditions to an automotive battery (V_{BAT} = 16V),

supply (V_{CC}), or ground. These devices include ±15kV ESD (Human Body Model) protection.

MAX9546

Driver

The MAX9546 driver converts a single-ended video input into a differential output for transport across a twisted pair of wires. The input is AC-coupled and the video signal sync tip is clamped at 3.46V to set the voltage of the input. The output common-mode voltage is optimized to reject ground differences between the MAX9546 and MAX9547 up to ±2V. The differential gain is internally set to 2V/V to drive a back-terminated output to unity gain. The maximum input resistance should not exceed 400Ω to ensure device stability.

Differential Video Interface Chipset

Common-Mode Balance

A driver is typically specified as having a property called common-mode balance (CMB), longitudinal balance, or simply line imbalance. Although balance is associated with the source, it assumes a perfectly balanced, correctly terminated, differential load. Common-mode balance is a measure of the ratio between the differential to the common-mode output in decibels as shown below.

$$\text{CMB} = 20 \text{Log} \left(\frac{(\text{OUT}+) - (\text{OUT}-)}{(\text{OUT}+) + (\text{OUT}-)} \right)$$

Common-mode balance is dominated by the gain-bandwidth product at high frequencies and the output resistance at low frequencies; therefore, it is important to specify CMB over a frequency range. The receiver-side balance is determined by the common-mode rejection ratio (CMRR). The CMRR is usually quite large compared to the CMB; therefore, the CMB is the limiting factor.

Fault Protection and Detection

The MAX9546 fault protection insures the driver outputs survive a short to any voltage from -2V to +16V and are ESD-protected to $\pm 15\text{kV}$ HBM. Faults are indicated by an open-drain fault output ($\overline{\text{FAULT}}$) being asserted low and requires a pullup resistor from $\overline{\text{FAULT}}$ to V_{CC} .

MAX9547

Receiver

The MAX9547 receiver is a differential-to-single-ended converter that removes any common-mode input. The unique architecture allows the signal gain to be set by a ratio of two impedances: the user-selected transconductance element or network (Z_{ZT}), and an output load resistance, R_L . The gain is set by a fixed internal current gain (K) and the ratio of Z_{ZT} and R_L . The ZT terminals can be bridged with a complex impedance to provide lead-lag compensation.

The output is essentially a voltage-controlled current source as shown in Figure 1. The MAX9547 output is a current proportional to the differential input voltage, and inversely proportional to the impedance of the user-selected transconductance network, Z_{ZT} . The current output provides inherent short-circuit protection for the output terminal. A differential input voltage applied to the input terminals causes current to flow in the transconductance element (Z_{ZT}), which is equal to V_{IN} / Z_{ZT} . This current in the transconductance element is multiplied by the preset current gain (K) and appears on the output terminal as a current equal to $(K) \times (V_{IN} / Z_{ZT})$. This current flows through the load impedance to produce an output voltage according to the following equation:

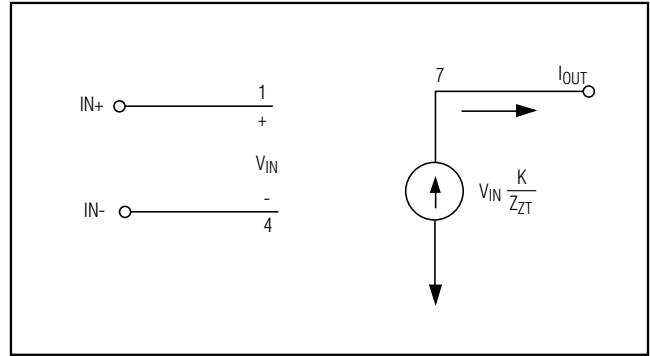

Figure 1. Operational Mode

$$V_{OUT} = K \left(\frac{V_{IN}}{Z_{ZT}} \right) R_L$$

where K = current-gain ratio ($K = 1$ for MAX9547), R_L = output load impedance, Z_{ZT} = transconductance element impedance, V_{IN} = differential input voltage.

Loss-of-Signal

The receiver includes an $\overline{\text{LOS}}$ output to indicate a signal by detecting the presence of H-Sync. This allows the MAX9547 to be used with monochrome or color video. $\overline{\text{LOS}}$ is an open-drain output and requires a pullup resistor from $\overline{\text{LOS}}$ to V_{CC} .

Setting the Circuit Gain

The MAX9547 produces an output current by multiplying the differential input voltage, V_{IN} , by the transconductance ratio, $K (R_L / Z_{ZT})$, where $K = 1$. The voltage gain (A_V) is set by the impedance of the transconductance network (Z_{ZT}) and the output load impedance (R_L) according to the following formula:

$$A_V = K \left(\frac{R_L}{Z_{ZT}} \right)$$

The factor Z_{ZT} is the impedance of the user-selected, two-terminal transconductance element or network, connected across the terminals labeled ZT+ and ZT-. The network Z_{ZT} is selected, along with the output impedance R_L , to provide the desired circuit gain and frequency shaping.

To maintain linearity, the transconductance network should also be selected so that current flowing through it, equal to V_{IN} / Z_{ZT} , does not exceed 18mA under worst-case conditions of maximum input voltage and minimum transconductance element impedance (Z_{ZT}). Output current should not exceed $\pm 8.8\text{mA}$ except under fault conditions.

Differential Video Interface Chipset

Applications Information

Differential Interface

The impedances of the differential interface are made up of the two source resistors on the driver (MAX9546) shown as R_S and the load resistors on the receiver (MAX9547) shown as R_T in the *Typical Application Circuit*. These resistors are chosen so their sum matches the characteristic impedance (Z_0) of the differential transmission line. For example, a Category 5 cable has a characteristic impedance of 110Ω , so the sum of the two R_S or R_T resistors must be 110Ω to correctly drive the line. To balance the signals they must be equal, so R_S and R_T are 55Ω each.

$\pm 15kV$ ESD Protection

As with all Maxim devices, ESD-protection structures are incorporated on all pins to protect against electrostatic discharges encountered during handling and assembly. The driver outputs and receiver inputs have extra protection against static electricity. Maxim's engineers developed state-of-the-art structures to protect these pins against ESD of $\pm 15kV$ without damage. The

ESD structures withstand high ESD in all states: normal operation and powered down. After an ESD event, the MAX9546/MAX9547 keep working without latchup. ESD protection can be tested in various ways; the driver outputs and receiver inputs of this product family are characterized for protection to $\pm 15kV$ using the Human Body Model. Other ESD test methodologies include IEC 1000-4-2 Contact Discharge and IEC 1000-4-2 Air-Gap Discharge (formerly IEC 801-2).

ESD Test Conditions

ESD performance depends on a variety of conditions. Contact Maxim for a reliability report that documents test setup, test methodology, and test results.

Human Body Model

Figure 2 shows the Human Body Model, and Figure 3 shows the current waveform it generates when discharged into a low impedance. This model consists of a $100pF$ capacitor charged to the ESD voltage of interest, which is then discharged into the test device through a $1.5k\Omega$ resistor.

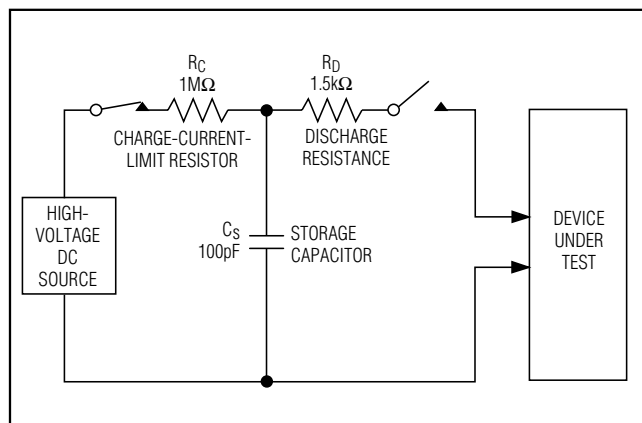

Figure 2. Human Body ESD Test Model

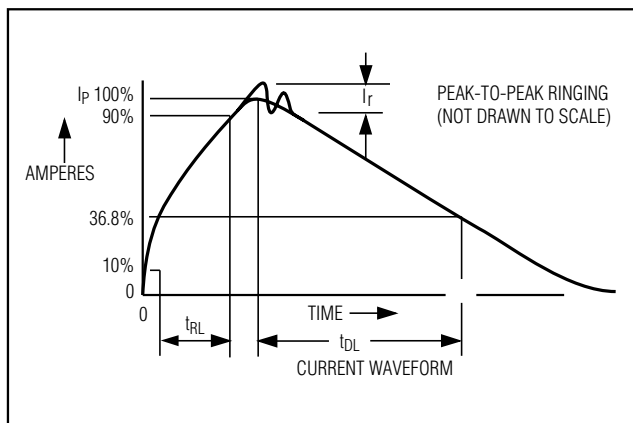

Figure 3. Human Body Current Waveform

Differential Video Interface Chipset

IEC 1000-4-2

The IEC 1000-4-2 standard covers ESD testing and performance of finished equipment; it does not specifically refer to integrated circuits (Figure 4).

The major difference between tests done using the Human Body Model and IEC 1000-4-2 is higher peak current in IEC 1000-4-2, because series resistance is lower in the IEC 1000-4-2 model. Hence, the ESD with-

stand voltage measured to IEC 1000-4-2 is generally lower than that measured using the Human Body Model. Figure 5 shows the current waveform for the $\pm 8\text{kV}$ IEC 1000-4-2 ESD Contact-Discharge test. The Air-Gap test involves approaching the device with a charged probe. The Contact-Discharge method connects the probe to the device before the probe is energized.

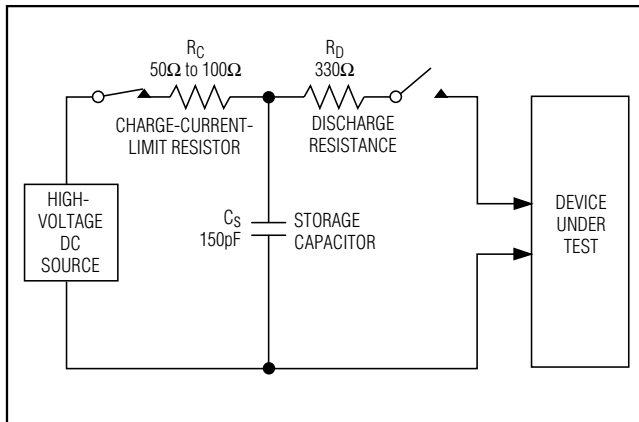

Figure 4. IEC 1000-4-2 ESD Test Model

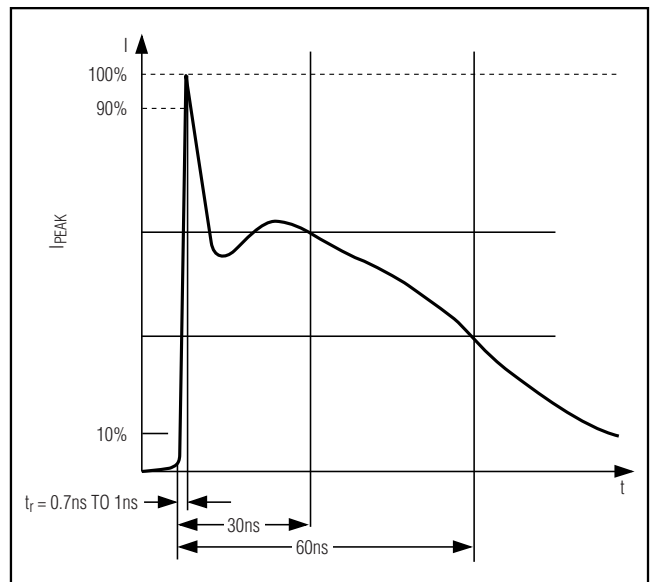
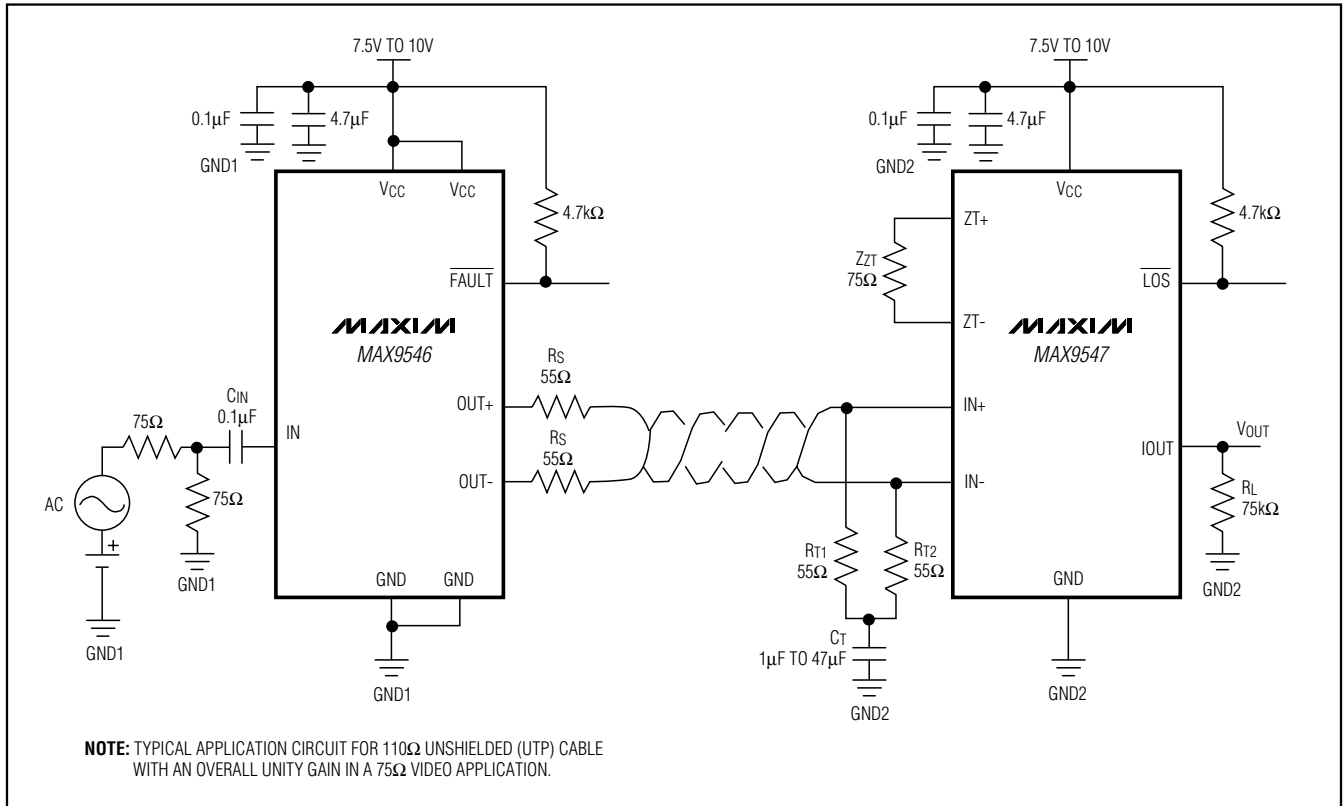

Figure 5. IEC 1000-4-2 ESD Generator Current Waveform

Differential Video Interface Chipset

Typical Application Circuit

MAX9546/MAX9547



Pin Configurations

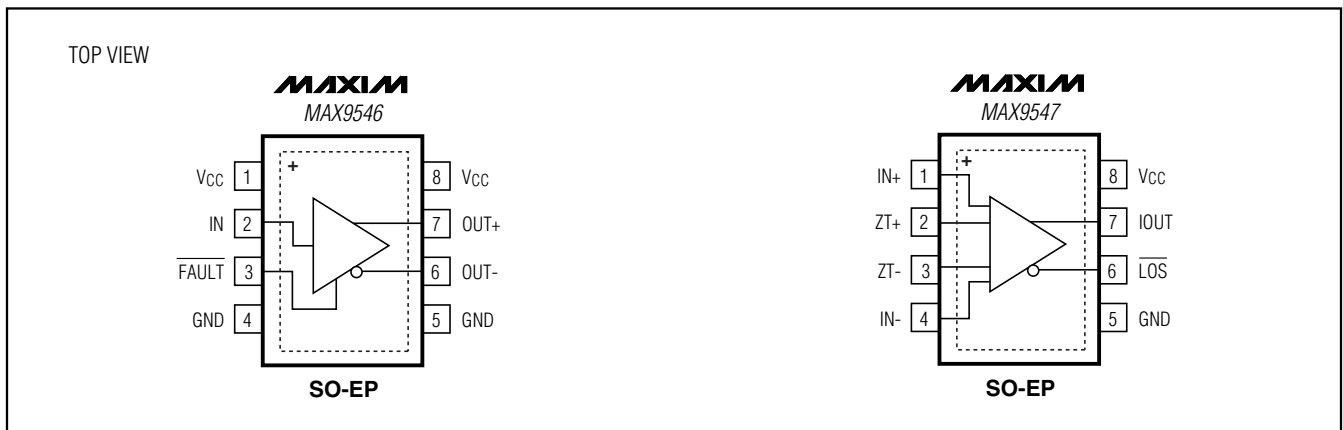

Chip Information

PROCESS: BICMOS

Differential Video Interface Chipset

Package Information

(The package drawing(s) in this data sheet may not reflect the most current specifications. For the latest package outline information go to www.maxim-ic.com/packages.)

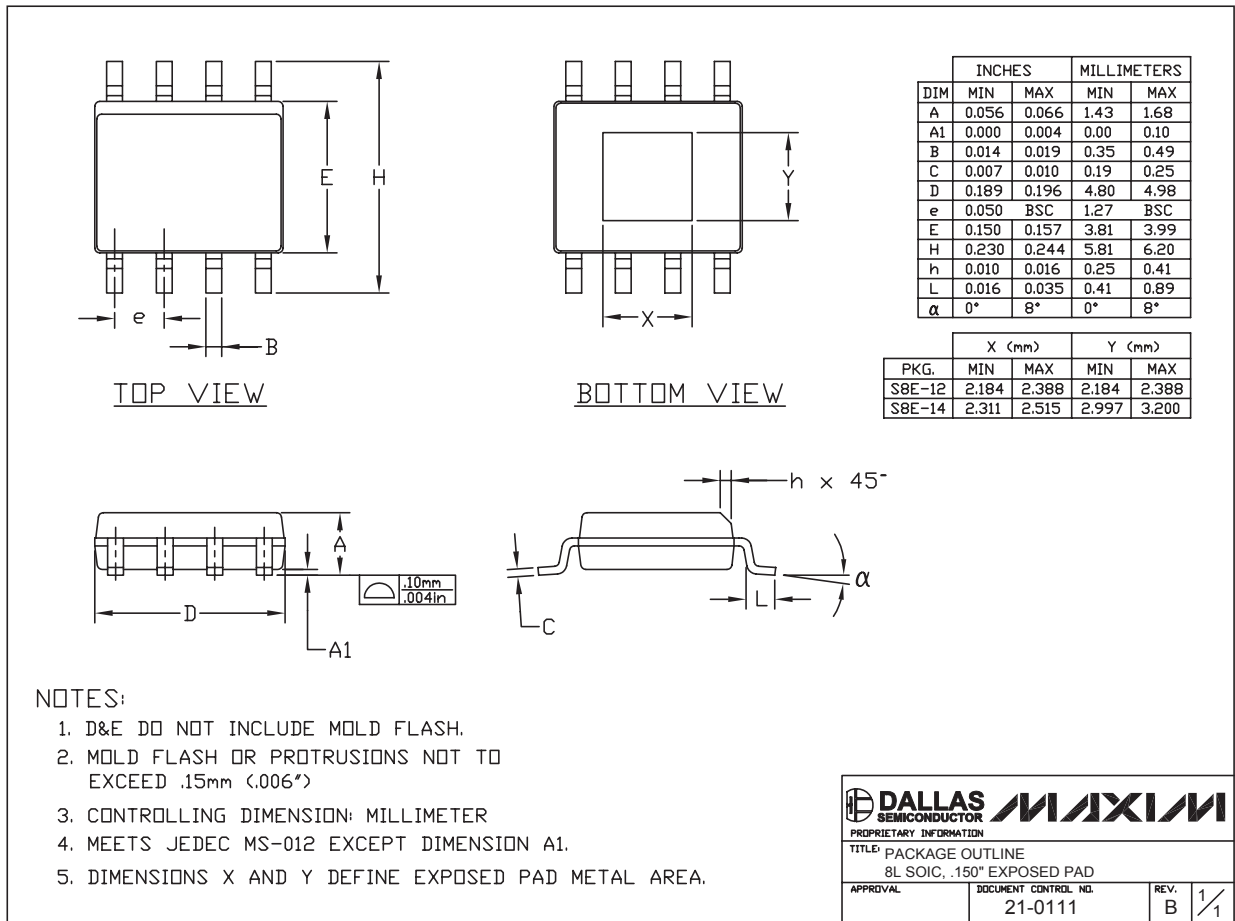

8L SOIC EXP. PADS

DALLAS SEMICONDUCTOR **MAXIM**

PROPRIETARY INFORMATION

TITLE: PACKAGE OUTLINE
8L SOIC, .150" EXPOSED PAD

APPROVAL	DOCUMENT CONTROL NO. 21-0111	REV. B	1/1
----------	---------------------------------	-----------	-----

Maxim cannot assume responsibility for use of any circuitry other than circuitry entirely embodied in a Maxim product. No circuit patent licenses are implied. Maxim reserves the right to change the circuitry and specifications without notice at any time.

12 **Maxim Integrated Products, 120 San Gabriel Drive, Sunnyvale, CA 94086 408-737-7600**