

EVALUATION KIT  
AVAILABLE

MAXIM

# 1.8V, Ultra-Low-Power, DirectDrive Video Filter Amplifier with Load Detect

MAX9516

## General Description

Operating at 1.8V from a single power supply, the MAX9516 amplifies standard-definition video signals and only consumes 6mW quiescent power and 12mW average power. The MAX9516 leverages Maxim's DirectDrive™ technology. Combining DirectDrive with the external positive 1.8V supply, the MAX9516 is able to drive a 2V<sub>P-P</sub> video signal into a 150Ω load. The MAX9516 has the ability to detect and report the presence of a video load and reduce power consumption when the load is not present.

The MAX9516 can detect the presence of a video load and report a change in load through the LOAD flag. This feature helps reduce overall system power consumption because the video encoder and the MAX9516 only need to be turned on when a video load is connected. If no load is connected, the MAX9516 is placed in an active-detect mode and only consumes 31μW.

Maxim's DirectDrive technology eliminates large output-coupling capacitors and sets the output video black level near ground. DirectDrive requires an integrated charge pump and an internal linear regulator to create a clean negative power supply so that the amplifier can pull the sync below ground. The charge pump injects so little noise into the video output that the picture is visibly flawless.

The MAX9516 features an internal reconstruction filter that smoothes the steps and reduces the spikes on the video signal from the video digital-to-analog converter (DAC). The reconstruction filter typically has ±1dB passband flatness of 7.5MHz, and 46dB (typ) attenuation at 27MHz.

The input of the MAX9516 can be directly connected to the output of a video DAC. The MAX9516 also features a transparent input sync-tip clamp, allowing AC-coupling of input signals with different DC biases.

The MAX9516 has an internal fixed gain of 8. The input full-scale video signal is nominally 0.25V<sub>P-P</sub>, and the output full-scale video signal is nominally 2V<sub>P-P</sub>.

## Applications

- Digital Still Cameras (DSC)
- Digital Video Cameras (DVC)
- Mobile Phones
- Portable Media Players (PMP)
- Security/CCTV Cameras
- Automotive Applications

## Features

- ◆ 1.8V or 2.5V Single-Supply Operation
- ◆ Low Power Consumption (6mW Quiescent, 12mW Average)
- ◆ Video Load Detect
- ◆ Reconstruction Filter with 5.5MHz Passband
- ◆ DirectDrive Sets Video Output Black Level Near Ground
- ◆ DC-Coupled Input/Output
- ◆ Transparent Input Sync-Tip Clamp

## Ordering Information

PART	PIN-PACKAGE	PKG CODE	TOP MARK
MAX9516ALB+T	10 μDFN-10	L1022+1	AAN

**Note:** This device operates over the -40°C to +125°C operating temperature range.

+ Denotes lead-free package.

T = Tape and reel.

## Block Diagram

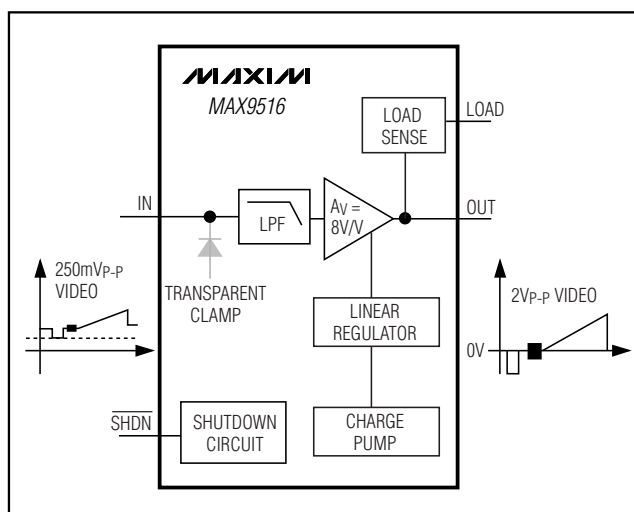

Pin Configuration appears at end of data sheet.

MAXIM

Maxim Integrated Products 1

For pricing, delivery, and ordering information, please contact Maxim Direct at 1-888-629-4642, or visit Maxim's website at [www.maxim-ic.com](http://www.maxim-ic.com).

# 1.8V, Ultra-Low-Power, DirectDrive Video Filter Amplifier with Load Detect

## ABSOLUTE MAXIMUM RATINGS

(Voltages with respect to GND.)

V <sub>DD</sub>	-0.3V to +3V
CPGND	-0.1V to +0.1V
IN	-0.3V to (V <sub>DD</sub> + 0.3V)
OUT	(The greater of V <sub>SS</sub> and -1V) to (V <sub>DD</sub> + 0.3V)
SHDN	-0.3V to +4V
C1P	-0.3V to (V <sub>DD</sub> + 0.3V)
C1N	(V <sub>SS</sub> - 0.3V) to +0.3V
V <sub>SS</sub>	-3V to +0.3V

Duration of OUT Short Circuit to V<sub>DD</sub>,

GND, and V <sub>SS</sub>	Continuous
Continuous Current	
IN, SHDN, LOAD	±20mA
Continuous Power Dissipation (T <sub>A</sub> = +70°C)	
10-Pin µDFN (derate 5mW/°C above +70°C)	403mW
Operating Temperature Range	-40°C to +125°C
Junction Temperature	+150°C
Storage Temperature Range	-65°C to +150°C
Lead Temperature (soldering, 10s)	+300°C

Stresses beyond those listed under "Absolute Maximum Ratings" may cause permanent damage to the device. These are stress ratings only, and functional operation of the device at these or any other conditions beyond those indicated in the operational sections of the specifications is not implied. Exposure to absolute maximum rating conditions for extended periods may affect device reliability.

## ELECTRICAL CHARACTERISTICS

(V<sub>DD</sub> = SHDN = +1.8V, GND = 0V, OUT has R<sub>L</sub> = 150Ω connected to GND, C1 = C2 = 1µF, T<sub>A</sub> = T<sub>MIN</sub> to T<sub>MAX</sub>, unless otherwise noted. Typical values are at V<sub>DD</sub> = 1.8V, T<sub>A</sub> = +25°C.) (Note 1)

PARAMETER	SYMBOL	CONDITIONS		MIN	TYP	MAX	UNITS
Supply Voltage Range	V <sub>DD</sub>	Guaranteed by PSRR		1.700		2.625	V
Supply Current	I <sub>DD</sub>	Amplifier ON, SHDN = V <sub>DD</sub>	Full operation mode, V <sub>IN</sub> = 0mV (Note 2)		3.1	5.3	mA
			Active-detect mode, no load		3		µA
Shutdown Supply Current	I <sub>SHDN</sub>	SHDN = GND			0.01	10	µA
Output Load Detect Threshold		R <sub>L</sub> to GND				200	Ω
Output Level		IN = 80mV		-85	+9	+85	mV
<b>DC-COUPLED INPUT</b>							
Input Voltage Range		Guaranteed by output-voltage swing	1.7V ≤ V <sub>DD</sub> ≤ 2.625V	0		262.5	mV
			2.375V ≤ V <sub>DD</sub> ≤ 2.625V	0		325	
Input Current	I <sub>B</sub>	IN = 130mV			2	3.5	µA
Input Resistance	R <sub>IN</sub>	10mV ≤ IN ≤ 250mV			295		kΩ
<b>AC-COUPLED INPUT</b>							
Sync-Tip Clamp Level	V <sub>CLP</sub>	C <sub>IN</sub> = 0.1µF		-8	0	+11	mV
Input-Voltage Swing		Guaranteed by output-voltage swing	1.7V ≤ V <sub>DD</sub> ≤ 2.625V			252.5	mV <sub>P-P</sub>
			2.375V ≤ V <sub>DD</sub> ≤ 2.625V			325	
Sync Crush		Percentage reduction in sync pulse at output, R <sub>SOURCE</sub> = 37.5Ω, C <sub>IN</sub> = 0.1µF			1.3		%
Input Clamping Current		IN = 130mV			2	3.5	µA
Line Time Distortion		C <sub>IN</sub> = 0.1µF			0.2		%
Minimum Input Source Resistance					25		Ω

# 1.8V, Ultra-Low-Power, DirectDrive Video Filter Amplifier with Load Detect

MAX9516

## ELECTRICAL CHARACTERISTICS (continued)

( $V_{DD} = \overline{SHDN} = +1.8V$ ,  $GND = 0V$ , OUT has  $R_L = 150\Omega$  connected to GND,  $C_1 = C_2 = 1\mu F$ ,  $T_A = T_{MIN}$  to  $T_{MAX}$ , unless otherwise noted. Typical values are at  $V_{DD} = 1.8V$ ,  $T_A = +25^\circ C$ .) (Note 1)

PARAMETER	SYMBOL	CONDITIONS		MIN	TYP	MAX	UNITS
<b>DC CHARACTERISTICS</b>							
DC Voltage Gain	$A_V$	Guaranteed by output-voltage swing (Note 3)		7.84	8	8.16	V/V
Output-Voltage Swing		$1.7V \leq V_{DD} \leq 2.625V$	$0 \leq V_{IN} \leq 262.5mV$ , DC-coupled input	2.058	2.1	2.142	V <sub>P-P</sub>
			$0 \leq V_{IN} \leq 252.5mV_{P-P}$ , AC-coupled input	1.979	2.02	2.061	
		$2.375V \leq V_{DD} \leq 2.625V$	$0 \leq V_{IN} \leq 325mV$	2.548	2.6	2.652	
Power-Supply Rejection Ratio		$1.7V \leq V_{DD} \leq 2.625V$ , measured between $75\Omega$ load resistors		48	58		dB
Shutdown Input Resistance		$0V \leq IN \leq V_{DD}$ , $\overline{SHDN} = GND$			2.5		$M\Omega$
Output Resistance	$R_{OUT}$	OUT = 0V, $-5mA \leq I_{LOAD} \leq +5mA$			0.02		$\Omega$
Shutdown Output Resistance		$0V \leq OUT \leq V_{DD}$ , $\overline{SHDN} = GND$			10.0		$M\Omega$
OUT Leakage Current		$\overline{SHDN} = GND$				1	$\mu A$
Output Short-Circuit Current		Sourcing			81		mA
		Sinking			45		
<b>AC CHARACTERISTICS</b>							
Standard-Definition Reconstruction Filter		OUT = 2V <sub>P-P</sub> , reference frequency is 100kHz	$\pm 1dB$ passband flatness		7.5		MHz
			f = 5.5MHz		-0.2		dB
			f = 8.5MHz		-3.0		
			f = 27MHz		-48.7		
Differential Gain	DG	f = 3.58MHz			1.05		%
		f = 4.43MHz			1.1		
Differential Phase	DP	f = 3.58MHz			0.4		Degrees
		f = 4.43MHz			0.45		
Group-Delay Distortion		$100kHz \leq f \leq 5MHz$ , OUT = 2V <sub>P-P</sub>			16		ns
Peak Signal to RMS Noise		$100kHz \leq f \leq 5MHz$			64		dB
Power-Supply Rejection Ratio	PSRR	f = 100kHz, $V_{RIPPLE} = 100mV_{P-P}$			54		dB
2T Pulse-to-Bar K Rating		2T = 200ns, bar time is 18 $\mu s$ , the beginning 2.5% and the ending 2.5% of the bar time is ignored			0.1		K%
2T Pulse Response		2T = 200ns			0.3		K%
2T Bar Response		2T = 200ns, bar time is 18 $\mu s$ , the beginning 2.5% and the ending 2.5% of the bar time is ignored			0.1		K%

# 1.8V, Ultra-Low-Power, DirectDrive Video Filter Amplifier with Load Detect

## ELECTRICAL CHARACTERISTICS (continued)

( $V_{DD} = \overline{SHDN} = +1.8V$ ,  $GND = 0V$ ,  $OUT$  has  $R_L = 150\Omega$  connected to  $GND$ ,  $C1 = C2 = 1\mu F$ ,  $T_A = T_{MIN}$  to  $T_{MAX}$ , unless otherwise noted. Typical values are at  $V_{DD} = 1.8V$ ,  $T_A = +25^\circ C$ .) (Note 1)

PARAMETER	SYMBOL	CONDITIONS	MIN	TYP	MAX	UNITS
Nonlinearity		5-step staircase		0.2		%
Output Impedance		$f = 5MHz$ , $I_N = 80mV$		7.5		$\Omega$
$V_{OUT}$ -to- $V_{IN}$ Isolation		$\overline{SHDN} = GND$ , $f \leq 5.5MHz$		-78		dB
$V_{IN}$ -to- $V_{OUT}$ Isolation		$\overline{SHDN} = GND$ , $f \leq 5.5MHz$		-79		dB
<b>CHARGE PUMP</b>						
Switching Frequency			325	625	1150	kHz
<b>LOGIC SIGNALS</b>						
Logic-Low Threshold	$V_{IL}$	$\overline{SHDN}$ , $V_{DD} = 1.7V$ to $2.625V$			0.5	V
Logic-High Threshold	$V_{IH}$	$\overline{SHDN}$ , $V_{DD} = 1.7V$ to $2.625V$	1.4			V
Logic Input Current	$I_{IL}$ , $I_{IH}$	$\overline{SHDN}$			10	$\mu A$
Output High Voltage	$V_{OH}$	LOAD, $I_{OH} = 3mA$	$V_{DD} - 0.4$			V
Output Low Voltage	$V_{OL}$	LOAD, $I_{OL} = 3mA$			0.4	V

**Note 1:** All devices are 100% production tested at  $T_A = +25^\circ C$ . Specifications over temperature limits are guaranteed by design.

**Note 2:** Supply current does not include current supplied to  $V_{OUT}$  load.

**Note 3:** Voltage gain ( $A_V$ ) is a two-point measurement in which the output-voltage swing is divided by the input-voltage swing.

## Typical Operating Characteristics

( $V_{DD} = \overline{SHDN} = 1.8V$ ,  $GND = 0V$ , video output has  $R_L = 150\Omega$  connected to  $GND$ ,  $T_A = +25^\circ C$ , unless otherwise noted.)

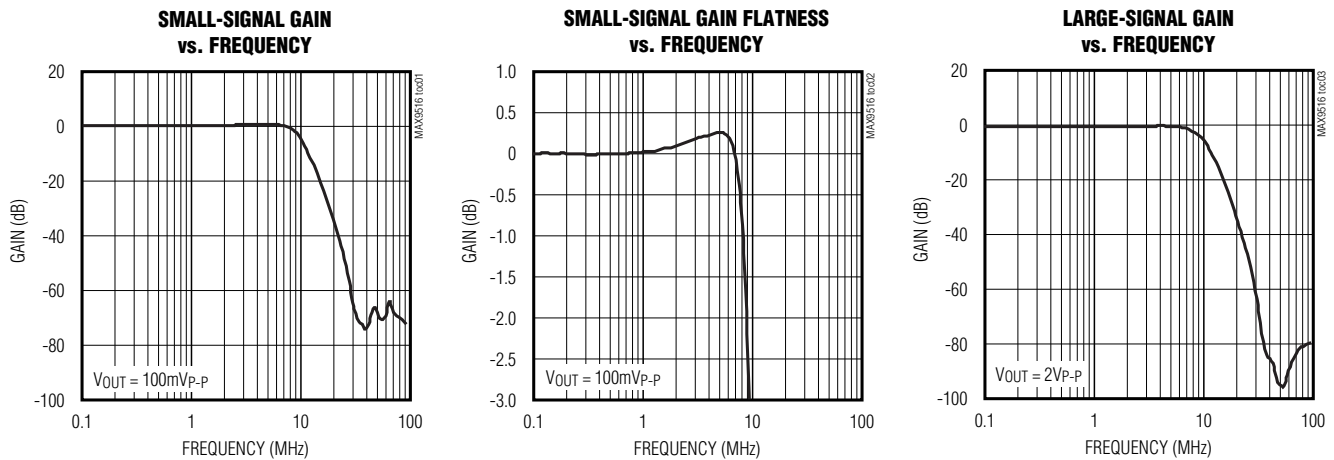

# 1.8V, Ultra-Low-Power, DirectDrive Video Filter Amplifier with Load Detect

MAX9516

## Typical Operating Characteristics (continued)

( $V_{DD} = \overline{SHDN} = 1.8V$ ,  $GND = 0V$ , video output has  $R_L = 150\Omega$  connected to  $GND$ ,  $T_A = +25^\circ C$ , unless otherwise noted.)

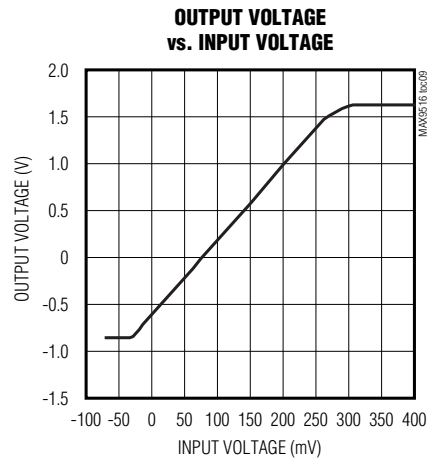
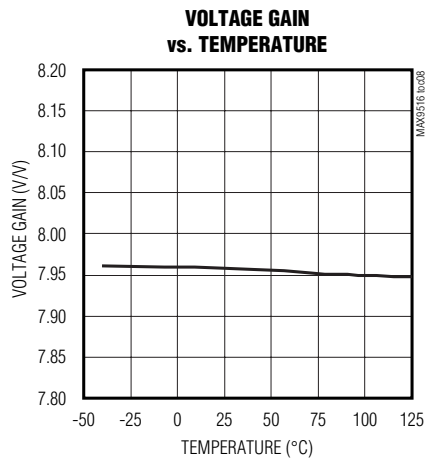
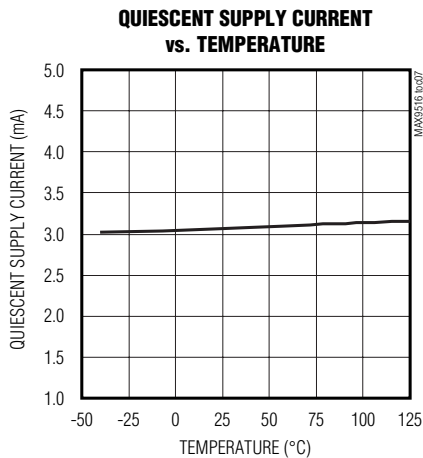
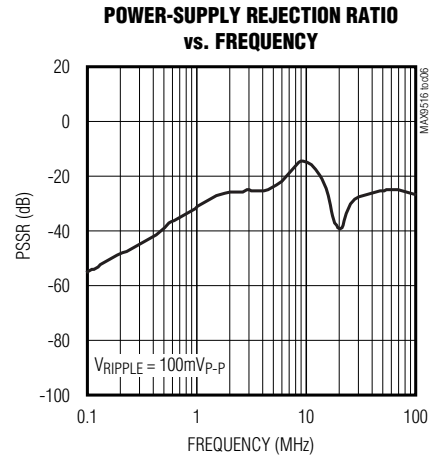
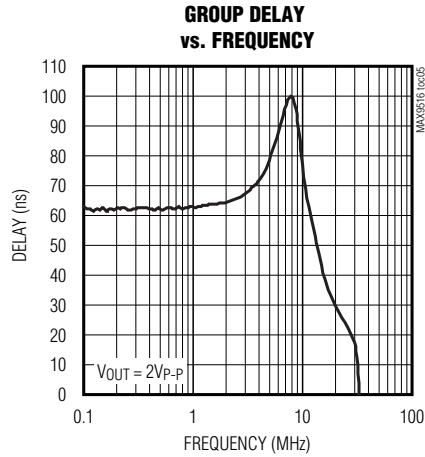
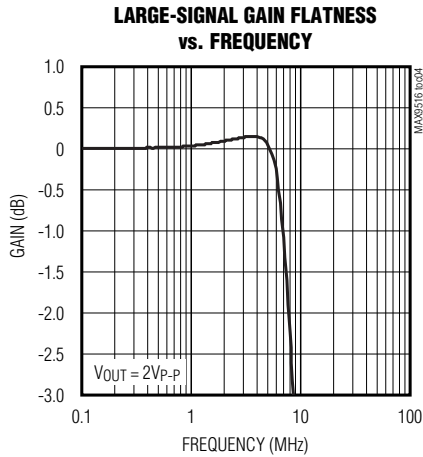

# 1.8V, Ultra-Low-Power, DirectDrive Video Filter Amplifier with Load Detect

## Typical Operating Characteristics (continued)

( $V_{DD} = \overline{SHDN} = 1.8V$ ,  $GND = 0V$ , video output has  $R_L = 150\Omega$  connected to  $GND$ ,  $T_A = +25^\circ C$ , unless otherwise noted.)

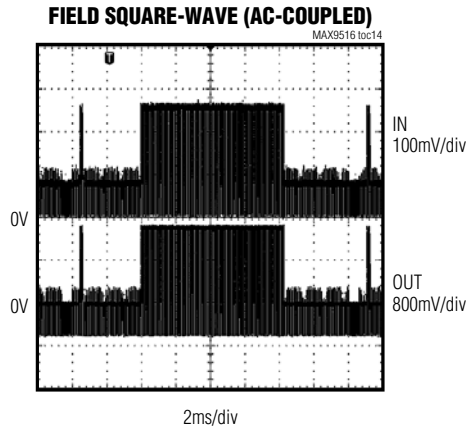
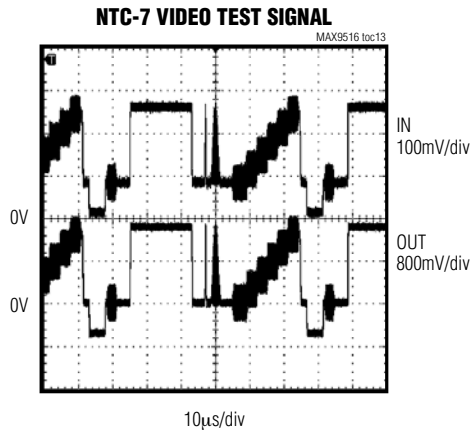
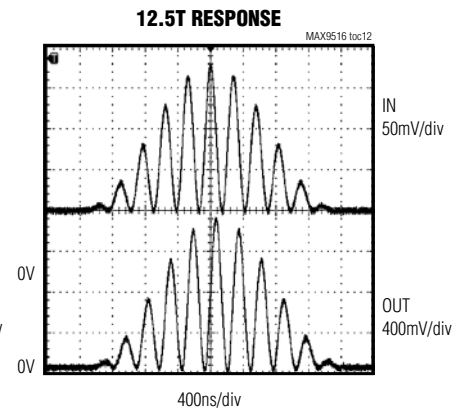
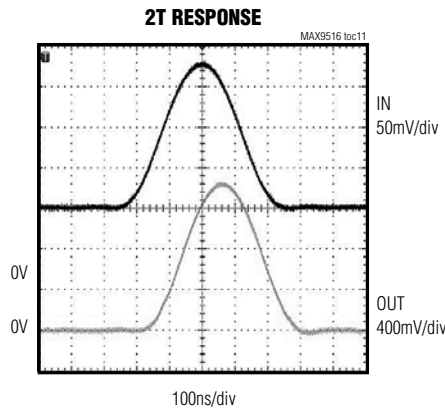
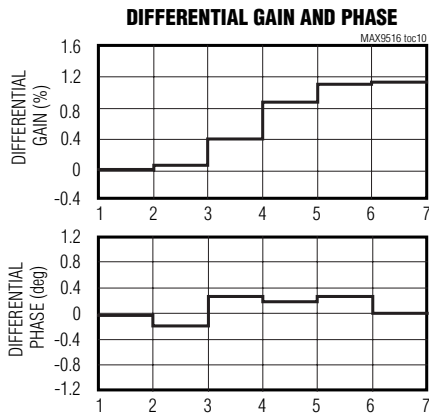

# 1.8V, Ultra-Low-Power, DirectDrive Video Filter Amplifier with Load Detect

## Pin Description

PIN	NAME	FUNCTION
1	VSS	Charge-Pump Negative Power Supply. Bypass with a 1 $\mu$ F capacitor to GND.
2	C1N	Charge-Pump Flying Capacitor Negative Terminal. Connect a 1 $\mu$ F capacitor from C1P to C1N.
3	CPGND	Charge-Pump Ground
4	C1P	Charge-Pump Flying Capacitor Positive Terminal. Connect a 1 $\mu$ F capacitor from C1P to C1N.
5	VDD	Positive Power Supply. Bypass with a 0.1 $\mu$ F capacitor to GND.
6	LOAD	Load-Detect Output. LOAD goes high when an output video load is detected.
7	GND	Ground
8	IN	Video Input
9	$\overline{\text{SHDN}}$	Active-Low Shutdown. Connect to VDD for normal operation.
10	OUT	Video Output

**MAX9516**

## Detailed Description

The MAX9516 represents Maxim's second-generation of DirectDrive video amplifiers, which meet the requirements of current and future portable equipment:

- 1.8V operation. Engineers want to eliminate the 3.3V supply in favor of lower supply voltages.
- Lower power consumption. The MAX9516 reduces average power consumption by up to 75% compared to the 3.3V first-generation devices (MAX9503/MAX9505).
- Internal fixed gain of 8. As the supply voltages drop for system chips on deep submicron processes, the video DAC can no longer create a 1V<sub>P-P</sub> signal at its output, and the gain of 2 found in the previous generation of video filter amps is not enough.
- Active-detect mode reduces power consumption.

DirectDrive technology is necessary for a voltage-mode amplifier to output a 2V<sub>P-P</sub> video signal from a 1.8V supply. The integrated inverting charge pump creates a negative supply that increases the output range and gives the video amplifier enough headroom to drive a 2V<sub>P-P</sub> video signal with a 150 $\Omega$  load.

### DirectDrive Background

Integrated video filter amplifier circuits operate from a single supply. The positive power supply usually creates video output signals that are level-shifted above ground to keep the signal within the linear range of the output amplifier. For applications where the positive DC level is not acceptable, a series capacitor can be inserted in the output connection in an attempt to elimi-

nate the positive DC level shift. The series capacitor cannot truly level-shift a video signal because the average level of the video varies with picture content. The series capacitor biases the video output signal around ground, but the actual level of the video signal can vary significantly depending upon the RC time constant and the picture content.

The series capacitor creates a highpass filter. Since the lowest frequency in video is the frame rate, which can be from 24Hz to 30Hz, the pole of the highpass filter should ideally be an order of magnitude lower in frequency than the frame rate. Therefore, the series capacitor must be very large, typically from 220 $\mu$ F to 3000 $\mu$ F. For space-constrained equipment, the series capacitor is unacceptable. Changing from a single-series capacitor to a SAG network that requires two smaller capacitors only reduces space and cost slightly.

The series capacitor in the usual output connection also prevents damage to the output amplifier if the connector is shorted to a supply or to ground. While the output connection of the MAX9516 does not have a series capacitor, the MAX9516 will not be damaged if the connector is shorted to a supply or to ground (see the *Short-Circuit Protection* section).

### Video Amplifier

If the full-scale video signal from a video DAC is 250mV, the black level of the video signal created by the video DAC is approximately 75mV. The MAX9516 shifts the black level to near ground at the output so that the active video is above ground and the sync is below ground. The amplifier needs a negative supply for its output stage to remain in its linear region when driving sync below ground.

# 1.8V, Ultra-Low-Power, DirectDrive Video Filter Amplifier with Load Detect

The MAX9516 has an integrated charge pump and linear regulator to create a low-noise negative supply from the positive supply voltage. The charge pump inverts the positive supply to create a raw negative voltage that is then fed into the linear regulator, which filters out the charge-pump noise.

## Comparison Between DirectDrive Output and AC-Coupled Output

The actual level of the video signal varies less with a DirectDrive output than an AC-coupled output. The average video signal level can change greatly depending upon the picture content. With an AC-coupled output, the average level will change according to the time constant formed by the series capacitor and series resistance (usually  $150\Omega$ ). For example, Figure 1 shows an AC-coupled video signal alternating between a completely black screen and a completely white screen. Notice the excursion of the video signal as the screen changes.

With the DirectDrive amplifier, the black level is held at ground. The video signal is constrained between  $-0.3V$  and  $+0.7V$ . Figure 2 shows the video signal from a DirectDrive amplifier with the same input signal as the AC-coupled system.

## Load Detection

The MAX9516 provides a video load detection feature. The device enters active-detect mode when it is enabled ( $\overline{SHDN} = V_{DD}$ ). Every 128ms, the part checks for a load by connecting a  $7.5k\Omega$  pullup resistor to the video output for 1ms. If the video output is pulled up during the test, then no load is present and LOAD is low. If the video output stays low during the test, then a load is connected and LOAD goes high. The state of LOAD is latched during the sleep time between sense pulses. All load-detect changes are deglitched over a nominal 128ms period. The status of the video load must remain constant during this deglitch period for LOAD to change state.

If a load is detected, the part enters the full operation mode and the amplifier, filter, and sync-tip clamp turn on. The part then continually checks if the load is present by sensing the sinking load current. Therefore, a black-burst signal (or output signal  $< 0V$ ) is required to maintain the detected load status. If the load remains present, the LOAD pin remains high. If the load is removed, LOAD goes low and the part goes back to the active-detect mode in which power consumption is typically  $31\mu W$ .

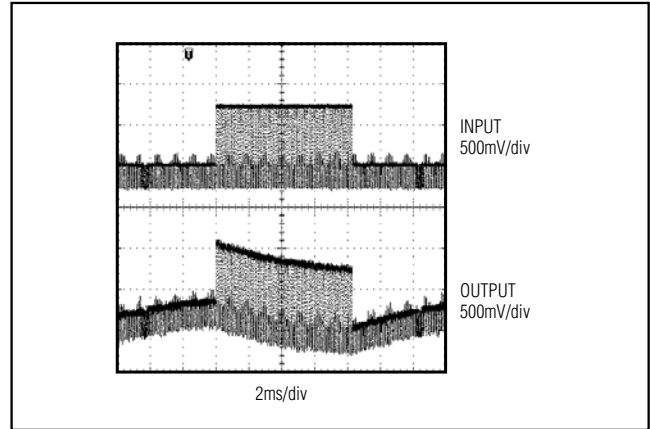

Figure 1. AC-Coupled Output

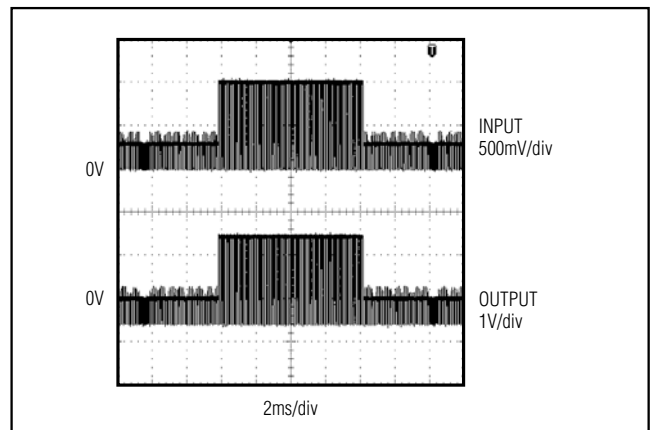

Figure 2. DirectDrive Output

## Video Reconstruction Filter

The MAX9516 includes an internal five-pole, Butterworth lowpass filter to condition the video signal. The reconstruction filter smooths the steps and reduces the spikes created whenever the DAC output changes value. In the frequency domain, the steps and spikes cause images of the video signal to appear at multiples of the sampling clock frequency. The reconstruction filter typically has  $\pm 1dB$  passband flatness of 7.5MHz and 46dB (typ) attenuation at 27MHz.

## Transparent Sync-Tip Input Clamp

The MAX9516 contains an integrated, transparent sync-tip clamp. When using a DC-coupled input, the sync-tip clamp does not affect the input signal, as long as it remains above ground. When using an AC-cou-



# 1.8V, Ultra-Low-Power, DirectDrive Video Filter Amplifier with Load Detect

pled input, the sync-tip clamp automatically clamps the input signal to ground, preventing it from going lower. A small current of 2 $\mu$ A pulls down on the input to prevent an AC-coupled signal from drifting outside the input range of the part.

Using an AC-coupled input will result in some additional variation of the black level at the output. Applying a voltage above ground to the input pin of the device always produces the same output voltage, regardless of whether the input is DC- or AC-coupled. However, since the sync-tip clamp level ( $V_{CLP}$ ) can vary over a small range, the video black level at the output of the device when using an AC-coupled input can vary by an additional amount equal to the  $V_{CLP}$  multiplied by the DC voltage gain ( $A_V$ ).

### Short-Circuit Protection

In Figure 7, the MAX9516 includes a 75 $\Omega$  back-termination resistor that limits short-circuit current if an external short is applied to the video output. The MAX9516 also features internal output short-circuit protection to prevent device damage in prototyping and applications where the amplifier output can be directly shorted.

### Shutdown

The MAX9516 features a low-power shutdown mode for battery-powered/portable applications. Shutdown reduces the quiescent current to less than 10nA. Connecting  $\overline{SHDN}$  to ground (GND) disables the output and places the MAX9516 into a low-power shutdown mode. In shutdown mode, the sync-tip clamp, filter, amplifier, charge pump, and linear regulator are turned off and the video output is high impedance.

## Applications Information

### Power Consumption

The quiescent power consumption and average power consumption of the MAX9516 is remarkably low because of the 1.8V operation and the DirectDrive technology. Quiescent power consumption ( $P_Q$ ) is the power consumed by the internal circuitry of the MAX9516. The formula for calculating  $P_Q$  is below.

$$P_Q = P_{TOTAL} - P_{LOAD}$$

$P_{TOTAL}$  is the total power drawn from the supply voltage, and  $P_{LOAD}$  is the power consumed by the load attached to OUT. For the MAX9516, the quiescent power consumption is typically 6mW.

Average power consumption, which is representative of the power consumed in a real application, is the total power drawn from the supply voltage for a MAX9516 driving a 150 $\Omega$  load to ground with a 50% flat field. Under such conditions, the average power consumption

**Table 1. Power Consumption of MAX9516 with Different Video Signals**

VIDEO SIGNAL	MAX9516 POWER CONSUMPTION (mW)
All Black Screen	6.7
All White Screen	18.2
75% Color Bars	11.6
50% Flat Field	11.7

for the MAX9516 is 12mW. Table 1 shows the power consumption with different video signals. The supply voltage is 1.8V. OUT drives a 150 $\Omega$  load to ground.

Notice that the two extremes in power consumption occur with a video signal that is all black and a video signal that is all white. The power consumption with 75% color bars and a 50% flat field lies in between the extremes.

### Interfacing to Video DACs that Produce Video Signals Larger than 0.25V<sub>p-p</sub>

Devices designed to generate 1V<sub>p-p</sub> video signals at the output of the video DAC can still work with the MAX9516. Most video DACs source current into a ground-referenced resistor, which converts the current into a voltage. Figure 3 shows a video DAC that creates a video signal from 0 to 1V across a 150 $\Omega$  resistor. The following video filter amplifier has a gain of 2V/V so that the output is 2V<sub>p-p</sub>.

The MAX9516 expects input signals that are 0.25V<sub>p-p</sub> nominally. The same video DAC can be made to work with the MAX9516 by scaling down the 150 $\Omega$  resistor to a 37.5 $\Omega$  resistor, as shown in Figure 4. The 37.5 $\Omega$  resistor is one-quarter of the 150 $\Omega$  resistor, resulting in a video signal that is one-quarter the amplitude.

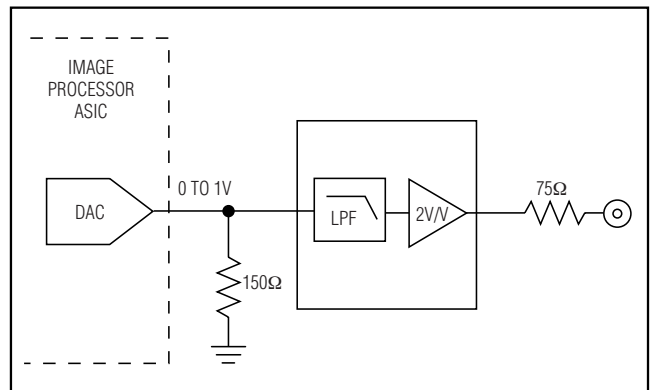

Figure 3. Video DAC generates a 1V<sub>p-p</sub> signal across a 150 $\Omega$  resistor connected to ground.

# 1.8V, Ultra-Low-Power, DirectDrive Video Filter Amplifier with Load Detect

## Anti-Alias Filter

The MAX9516 provides anti-alias filtering with buffering before an analog-to-digital converter (ADC), which is present in an NTSC/PAL video decoder, for example. Figure 5 shows an example application circuit. An external composite video signal is applied to VIDIN, which is terminated with a total of  $74\Omega$  ( $56\Omega$  and  $18\Omega$  resistors) to ground. The signal is attenuated by four, and then AC-coupled to IN. The normal  $1V_{p-p}$  video signal must be attenuated because with a 1.8V supply, the MAX9516 can handle only a video signal of approximately  $0.25V_{p-p}$  at IN. AC-couple the video signal to IN because the DC level of an external video signal is usually not well specified, although it is reasonable to expect that the signal is between  $-2V$  and  $+2V$ . The  $10\Omega$  series resistor increases the equivalent source resistance to about  $25\Omega$ , which is the minimum necessary for a video source to drive the internal sync-tip clamp.

For external video signals larger than  $1V_{p-p}$ , operate the MAX9516 from a 2.5V supply so that IN can accommodate a  $0.325V_{p-p}$  video signal, which is equivalent to a  $1.3V_{p-p}$  video signal at VIDIN.

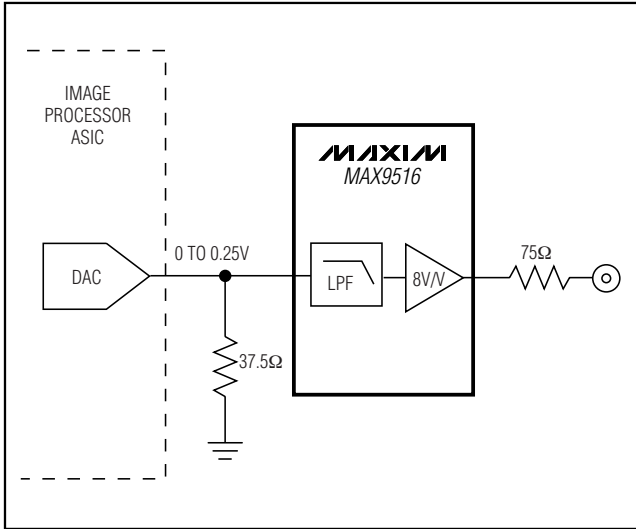

Figure 4. Video DAC Generates a  $0.25V_{p-p}$  Signal Across a  $37.5\Omega$  Resistor Connected to Ground

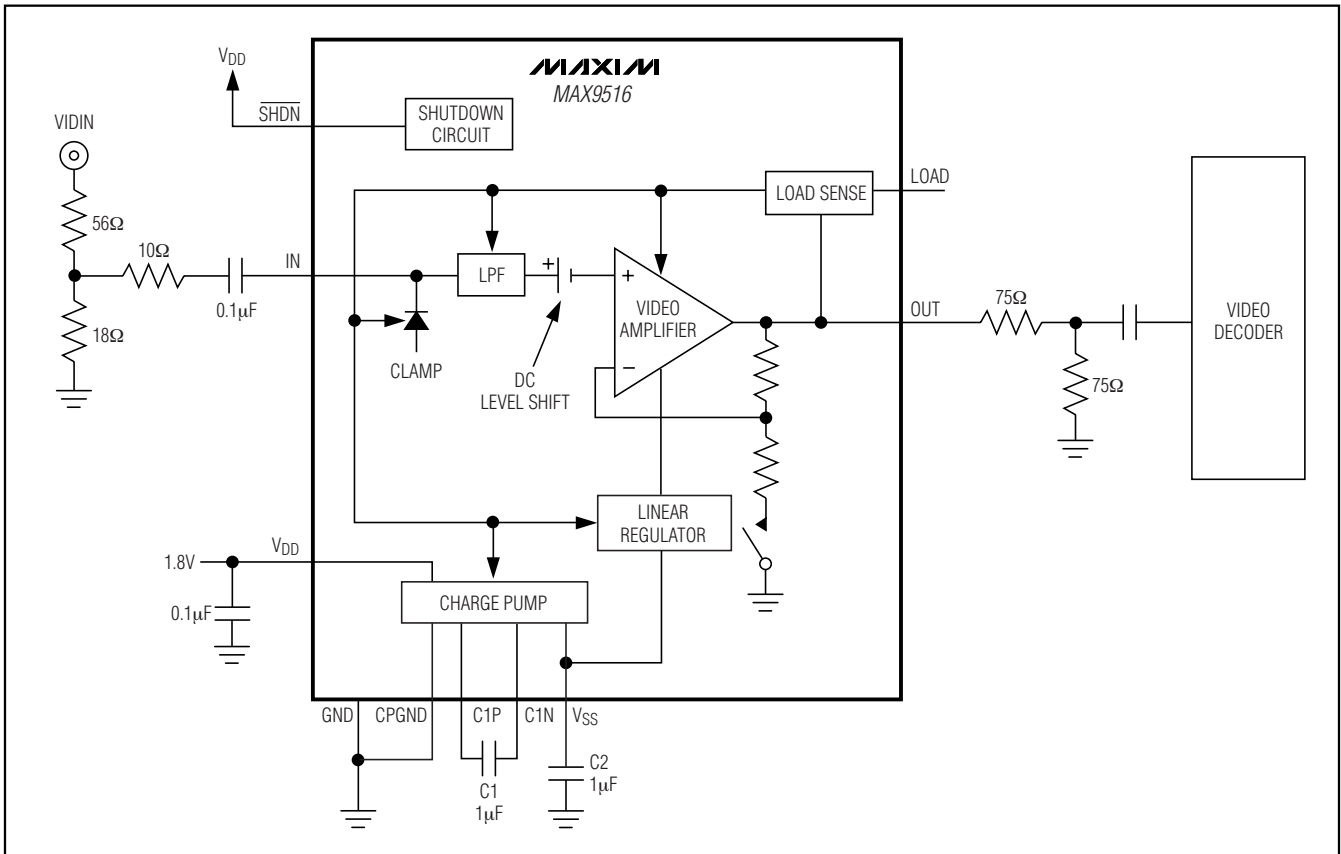

Figure 5. MAX9516 Used as an Anti-Alias Filter with Buffer

# 1.8V, Ultra-Low-Power, DirectDrive Video Filter Amplifier with Load Detect

## Video Source with a Positive DC Bias

In some applications, the video source generates a signal with a positive DC voltage bias, *i.e.*, the sync tip of the signal is well above ground. Figure 6 shows an example in which the outputs of the luma (Y) DAC and the chroma (C) DAC are connected together. Since the DACs are current mode, the output currents sum together into the resistor, which converts the resulting current into a voltage representing a composite video signal.

If the chroma DAC has an independent output resistor to ground, then the chroma signal, which is a carrier at 3.58MHz for NTSC or at 4.43MHz for PAL, has a positive DC bias to keep the signal above ground at all times. If the luma DAC has an independent output

resistor to ground, then the luma signal usually does not have a positive DC bias, and the sync tip is at approximately ground. When the chroma and luma signals are added together, the resulting composite video signal still has a positive DC bias. Therefore, the signal must be AC-coupled into the MAX9516 because the composite video signal is above the nominal, DC-coupled 0V to 0.25V input range.

## Video Signal Routing

Minimize the length of the PCB trace between the output of the video DAC and the input of the MAX9516 to reduce coupling of external noise into the video signal. If possible, shield the PCB trace.

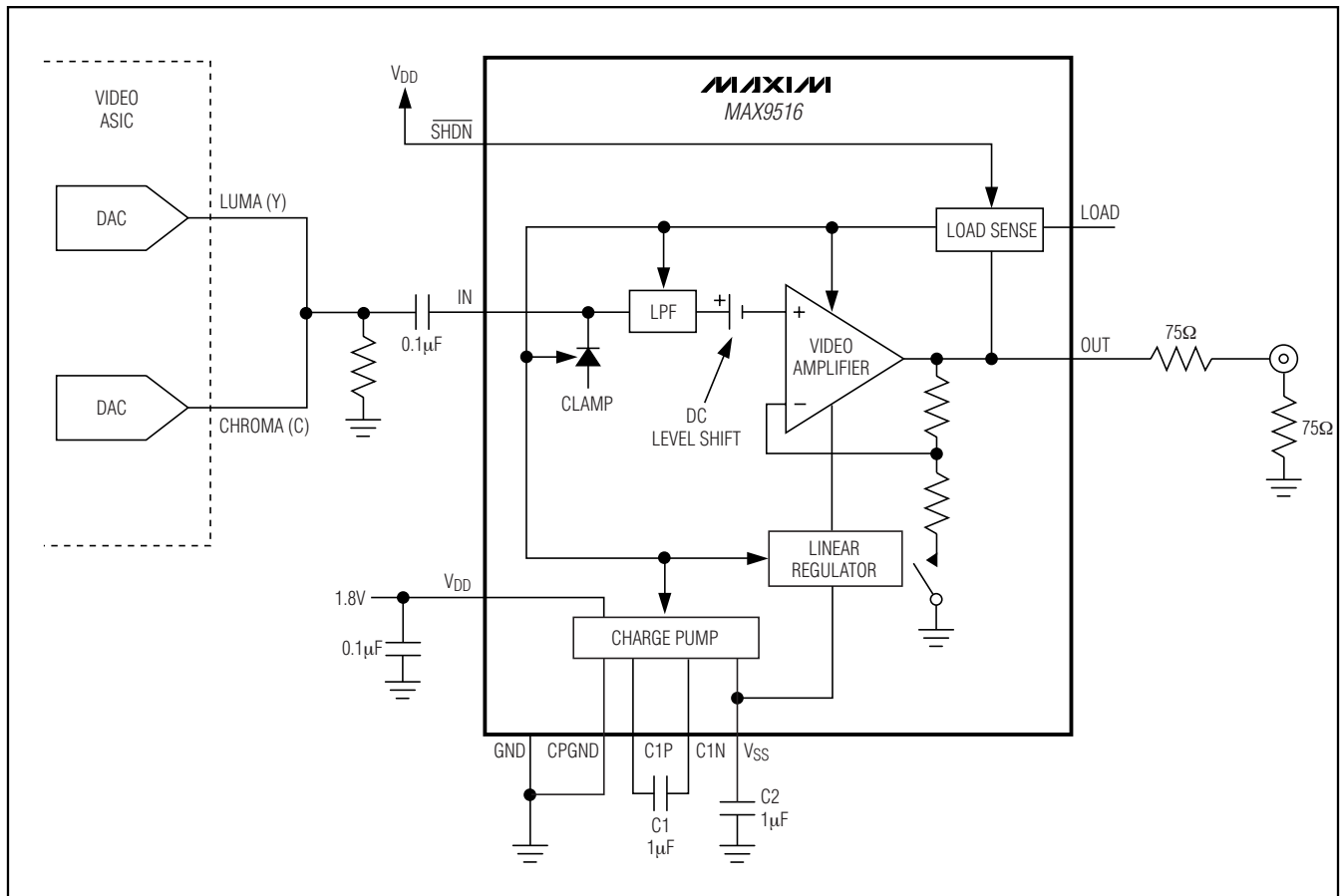

Figure 6. Luma (Y) and Chroma (C) Signals Added Together to Create Composite Video Signal (Which is AC-Coupled Into the MAX9516)

# 1.8V, Ultra-Low-Power, DirectDrive Video Filter Amplifier with Load Detect

## Power-Supply Bypassing and Ground Management

The MAX9516 operates from a 1.7V to 2.625V single supply and requires proper layout and bypassing. For the best performance, place the components as close to the device as possible.

Proper grounding improves performance and prevents any switching noise from coupling into the video signal. Bypass the analog supply ( $V_{DD}$ ) with a  $0.1\mu\text{F}$  capacitor to GND, placed as close to the device as possible. Bypass  $V_{SS}$  with a  $1\mu\text{F}$  capacitor to GND as close to the device as possible. The total system bypass capacitance on  $V_{DD}$  should be at least  $10\mu\text{F}$  or ten times the capacitance between C1P and C1N.

## Using a Digital Supply

The MAX9516 was designed to operate from noisy digital supplies. The high PSRR (54dB at 100kHz) allows the MAX9516 to reject the noise from the digital power supplies (see the *Typical Operating Characteristics*). If the digital power supply is very noisy and stripes appear on the television screen, increase the supply bypass capacitance. An additional, smaller capacitor in parallel with the main bypass capacitor can reduce digital supply noise because the smaller capacitor has lower equivalent series resistance (ESR) and equivalent series inductance (ESL).

## Typical Operating Circuits

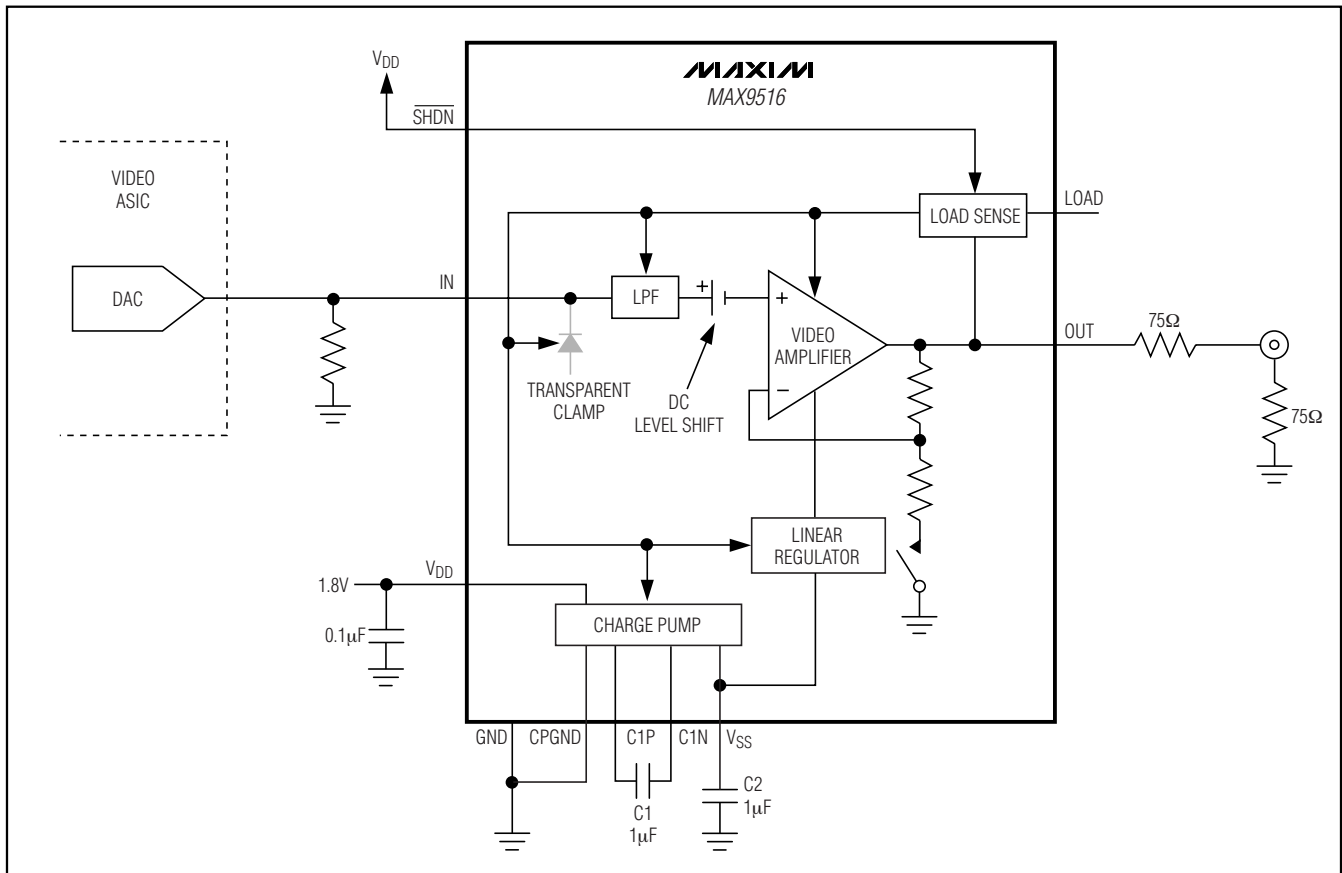

Figure 7. DC-Coupled Input

# 1.8V, Ultra-Low-Power, DirectDrive Video Filter Amplifier with Load Detect

Typical Operating Circuits (continued)

MAX9516

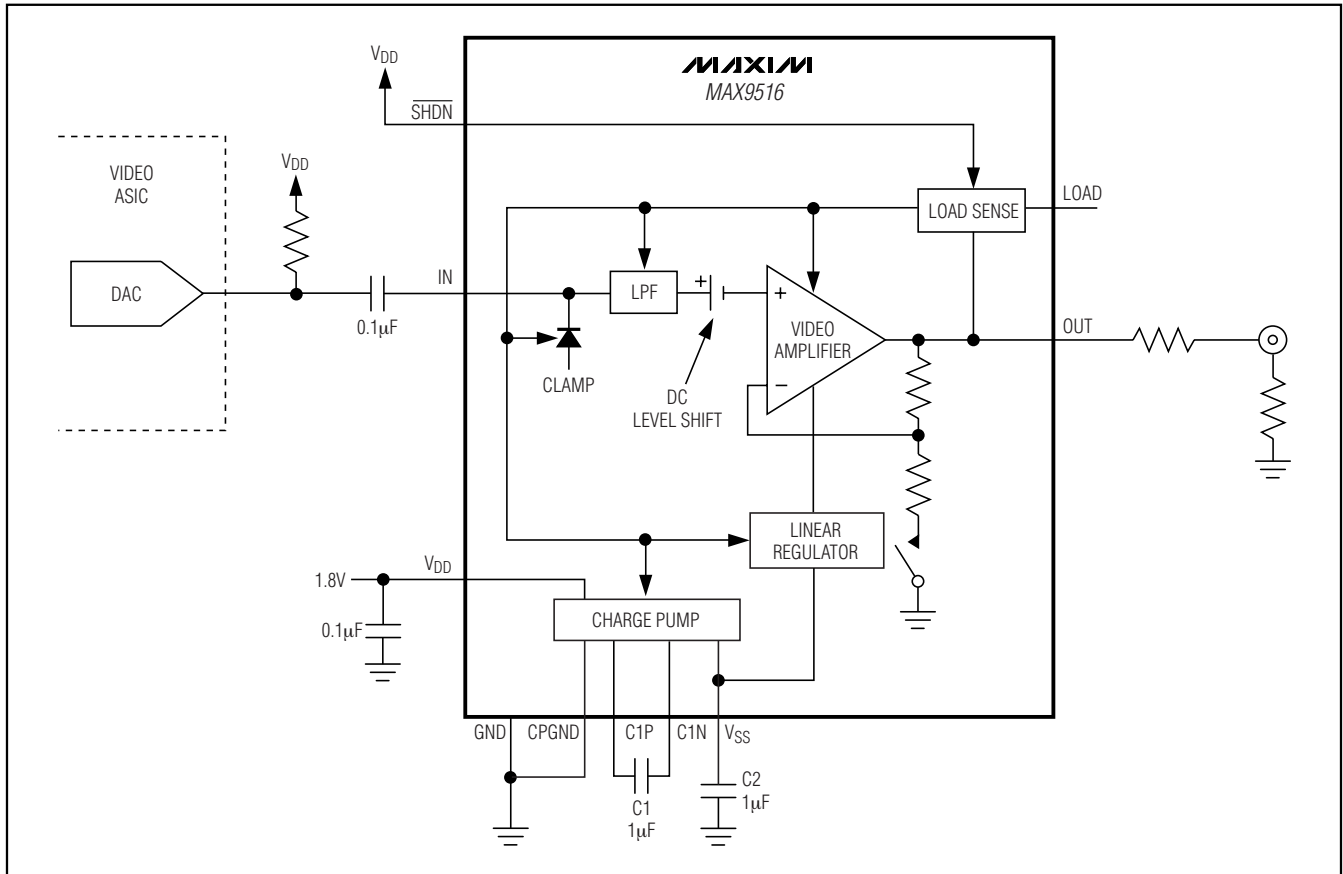
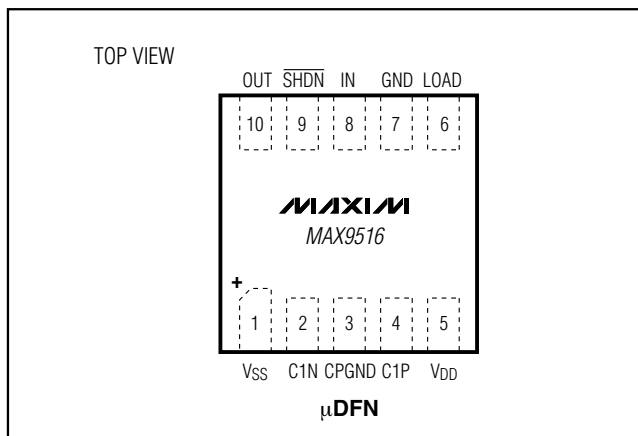

Figure 8. AC-Coupled Input

## Pin Configuration



## Chip Information

PROCESS: BiCMOS

# 1.8V, Ultra-Low-Power, DirectDrive Video Filter Amplifier with Load Detect

## Package Information

(The package drawing(s) in this data sheet may not reflect the most current specifications. For the latest package outline information go to [www.maxim-ic.com/packages](http://www.maxim-ic.com/packages).)

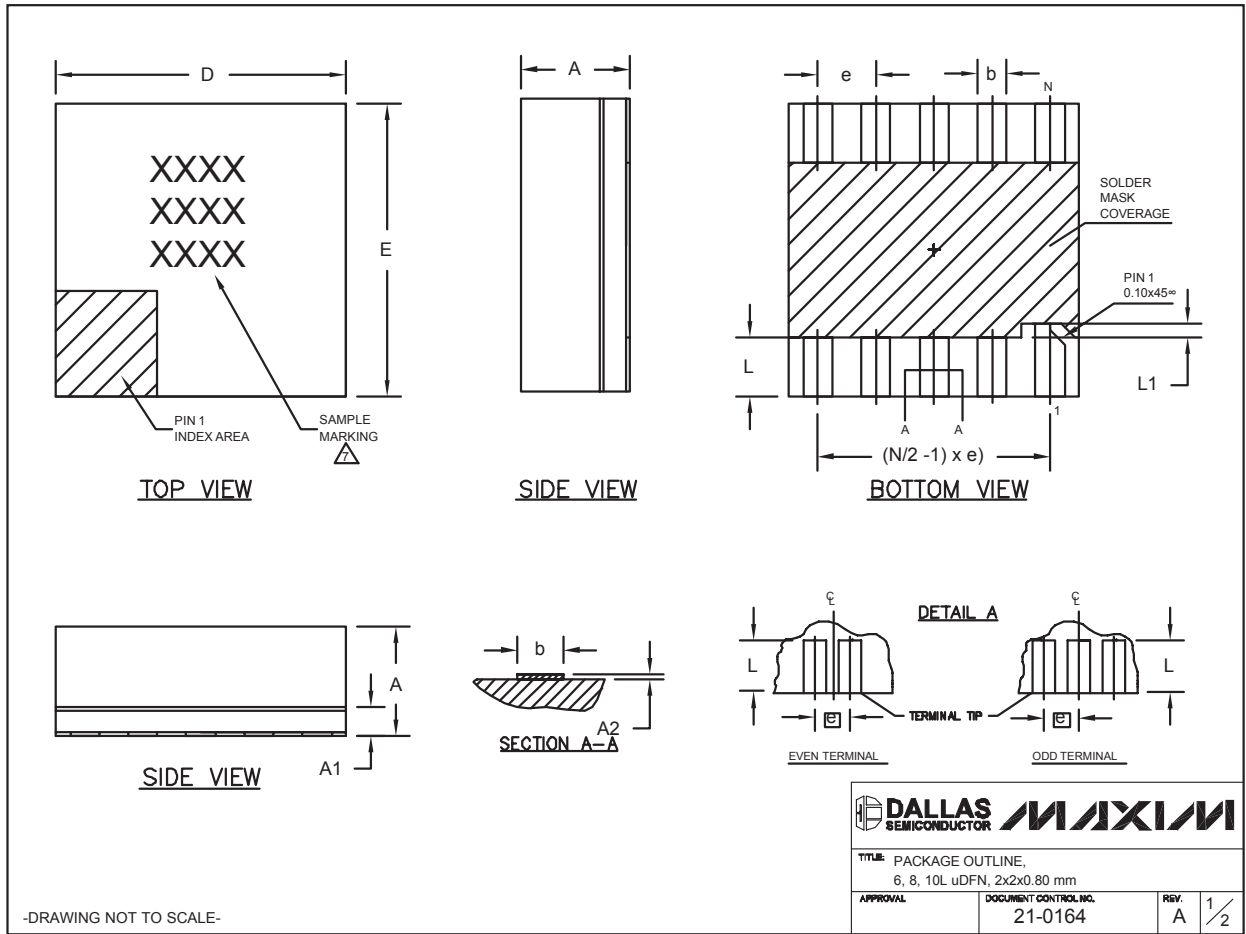

6, 8, 10L UDFN.EPS

<b>TITLE:</b> PACKAGE OUTLINE, 6, 8, 10L uDFN, 2x2x0.80 mm	
<b>APPROVAL</b>	<b>DOCUMENT CONTROL NO.</b> 21-0164
<b>REV.</b> A	<b>REV.</b> 1/2

# 1.8V, Ultra-Low-Power, DirectDrive Video Filter Amplifier with Load Detect

**MAX9516**

## Package Information (continued)

(The package drawing(s) in this data sheet may not reflect the most current specifications. For the latest package outline information go to [www.maxim-ic.com/packages](http://www.maxim-ic.com/packages).)

COMMON DIMENSIONS			
SYMBOL	MIN.	NOM.	MAX.
A	0.70	0.75	0.80
A1	0.15	0.20	0.25
A2	0.020	0.025	0.035
D	1.95	2.00	2.05
E	1.95	2.00	2.05
L	0.30	0.40	0.50
L1	0.10 REF.		

PACKAGE VARIATIONS				
PKG. CODE	N	e	b	(N/2 -1) x e
L622-1	6	0.65 BSC	0.30±0.05	1.30 REF.
L822-1	8	0.50 BSC	0.25±0.05	1.50 REF.
L1022-1	10	0.40 BSC	0.20±0.03	1.60 REF.

**NOTES:**

1. ALL DIMENSIONS ARE IN mm. ANGLES IN DEGREES.
  2. COPLANARITY SHALL NOT EXCEED 0.08mm.
  3. WARPAGE SHALL NOT EXCEED 0.10mm.
  4. PACKAGE LENGTH/PACKAGE WIDTH ARE CONSIDERED AS SPECIAL CHARACTERISTIC(S).
  5. "N" IS THE TOTAL NUMBER OF LEADS.
  6. NUMBER OF LEADS SHOWN ARE FOR REFERENCE ONLY.
-  MARKING IS FOR PACKAGE ORIENTATION REFERENCE ONLY.

-DRAWING NOT TO SCALE-

			
TITLE: PACKAGE OUTLINE, 6, 8, 10L uDFN, 2x2x0.80 mm			
APPROVAL	DOCUMENT CONTROL NO.	REV.	
	21-0164	A	2/2

Maxim cannot assume responsibility for use of any circuitry other than circuitry entirely embodied in a Maxim product. No circuit patent licenses are implied. Maxim reserves the right to change the circuitry and specifications without notice at any time.

Maxim Integrated Products, 120 San Gabriel Drive, Sunnyvale, CA 94086 408-737-7600 \_\_\_\_\_ 15