

RELIABILITY REPORT  
FOR  
**MAX811TEUS**  
PLASTIC ENCAPSULATED DEVICES

September 10, 2002

**MAXIM INTEGRATED PRODUCTS**

120 SAN GABRIEL DR.

SUNNYVALE, CA 94086

Written by



Jim Pedicord  
Quality Assurance  
Reliability Lab Manager

Reviewed by

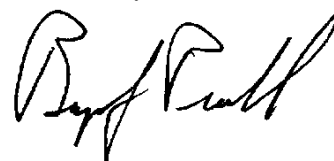

Bryan J. Preeshl  
Quality Assurance  
Executive Director

## Conclusion

The MAX811T successfully meets the quality and reliability standards required of all Maxim products. In addition, Maxim's continuous reliability monitoring program ensures that all outgoing product will continue to meet Maxim's quality and reliability standards.

## Table of Contents

I. ....Device Description	V. ....Quality Assurance Information
II. ....Manufacturing Information	VI. ....Reliability Evaluation
III. ....Packaging Information	
IV. ....Die Information	.....Attachments

### I. Device Description

#### A. General

The MAX811T is a low-power microprocessor ( $\mu\text{P}$ ) supervisory circuit used to monitor power supplies in  $\mu\text{P}$  and digital systems. It provides excellent circuit reliability and low cost by eliminating external components and adjustments when used with 5V- powered or 3V-powered circuits. The MAX811T also provides a debounced manual reset input.

This device performs a single function: It asserts a reset signal whenever the  $V_{\text{CC}}$  supply voltage falls below a preset threshold, keeping it asserted for at least 140ms after  $V_{\text{CC}}$  has risen above the reset threshold. The MAX811 has an active-low RESET output (which is guaranteed to be in the correct state for  $V_{\text{CC}}$  down to 1V. The reset comparator is designed to ignore fast transients on  $V_{\text{CC}}$ . Reset thresholds for this device is 3.08V.

Low supply current makes the MAX811T ideal for use in portable equipment. This device comes in a 4-pin SOT143 package.

#### B. Absolute Maximum Ratings

<u>Item</u>	<u>Rating</u>
Terminal Voltage (with respect to GND)	
VCC	-0.3V to 6.0V
All Other Inputs	-0.3V to (VCC + 0.3V)
Input Current, VCC, MR	20mA
Output Current, RESET or RESET	20mA
Operating Temperature Range	-40°C to +85°C
Storage Temperature Range	-65°C to +160°C
Lead Temperature (soldering, 10sec)	+300°C
Continuous Power Dissipation (TA = +70°C)	
4-Lead SOT143	320mW
Derates above +70°C	
4-Lead SOT143	4mW/°C

## II. Manufacturing Information

A. Description/Function:	4-Pin $\mu$ P Voltage Monitors with Manual Reset Input
B. Process:	S12 (SG1.2) - Standard 1.2 micron silicon gate CMOS
C. Fabrication Location:	Oregon, USA
D. Transistor Count:	341
D. Assembly Location:	Malaysia or Thailand
E. Date of Initial Production:	January, 1997

## III. Packaging Information

A. Package Type:	<b>4-Lead SOT143</b>
B. Lead Frame:	Copper
C. Lead Finish:	Solder Plate
D. Die Attach:	Silver-filled Epoxy
E. Bondwire:	Gold (1.0 mil dia.)
F. Mold Material:	Epoxy with silica filler
G. Assembly Diagram:	Buildsheet # 05-1701-0263
H. Flammability Rating:	Class UL94-V0
I. Classification of Moisture Sensitivity per JEDEC standard JESD22-A112:	Level 1

## IV. Die Information

A. Dimensions:	37 x 31 mils
B. Passivation:	$\text{Si}_3\text{N}_4/\text{SiO}_2$ (Silicon nitride/ Silicon dioxide)
C. Interconnect:	Aluminum/Copper/Si
D. Backside Metallization:	None
E. Minimum Metal Width:	1.2 microns (as drawn)
F. Minimum Metal Spacing:	1.2 microns (as drawn)
G. Bondpad Dimensions:	5 mil. Sq.
H. Isolation Dielectric:	$\text{SiO}_2$
I. Die Separation Method:	Wafer Saw

## V. Quality Assurance Information

- A. Quality Assurance Contacts: Jim Pedicord (Reliability Lab Manager)  
Bryan Preeshl (Executive Director of QA)  
Kenneth Huening (Vice President)
- B. Outgoing Inspection Level: 0.1% for all electrical parameters guaranteed by the Datasheet.  
0.1% For all Visual Defects.
- C. Observed Outgoing Defect Rate: < 50 ppm
- D. Sampling Plan: Mil-Std-105D

## VI. Reliability Evaluation

### A. Accelerated Life Test

The results of the 135°C biased (static) life test are shown in **Table 1**. Using these results, the Failure Rate ( $\lambda$ ) is calculated as follows:

$$\lambda = \frac{1}{\text{MTTF}} = \frac{1.83}{192 \times 4389 \times 240 \times 2} \quad (\text{Chi square value for MTTF upper limit})$$

▲  
Temperature Acceleration factor assuming an activation energy of 0.8eV

$$\lambda = 4.52 \times 10^{-9} \quad \lambda = 4.52 \text{ F.I.T. (60\% confidence level @ 25°C)}$$

This low failure rate represents data collected from Maxim's reliability qualification and monitor programs. Maxim also performs weekly Burn-In on samples from production to assure reliability of its processes. The reliability required for lots which receive a burn-in qualification is 59 F.I.T. at a 60% confidence level, which equates to 3 failures in an 80 piece sample. Maxim performs failure analysis on rejects from lots exceeding this level. The Burn-In Schematic (Spec. # 06-4556) shows the static circuit used for this test. Maxim also performs 1000 hour life test monitors quarterly for each process. This data is published in the Product Reliability Report (**RR-1M**).

### B. Moisture Resistance Tests

Maxim evaluates pressure pot stress from every assembly process during qualification of each new design. Pressure Pot testing must pass a 20% LTPD for acceptance. Additionally, industry standard 85°C/85%RH or HAST tests are performed quarterly per device/package family.

### C. E.S.D. and Latch-Up Testing

The PW67-2 die type has been found to have all pins able to withstand a transient pulse of  $\pm 2500\text{V}$ , per Mil-Std-883 Method 3015 (reference attached ESD Test Circuit). Latch-Up testing has shown that this device withstands a current of  $\pm 250\text{mA}$  and/or  $\pm 20\text{V}$ .

**Table 1**  
Reliability Evaluation Test Results

**MAX811TEUS**

<b>TEST ITEM</b>	<b>TEST CONDITION</b>	<b>FAILURE IDENTIFICATION</b>	<b>SAMPLE SIZE</b>	<b>NUMBER OF FAILURES</b>
<b>Static Life Test</b> (Note 1)				
	Ta = 135°C Biased Time = 192 hrs.	DC Parameters & functionality	240	0
<b>Moisture Testing</b>				
Pressure Pot	Ta = 121°C P = 15 psi. RH= 100% Time = 168hrs.	DC Parameters & functionality	77	0
85/85	Ta = 85°C RH = 85% Biased Time = 1000hrs.	DC Parameters & functionality	77	0
<b>Mechanical Stress</b>				
Temperature Cycle	-65°C/150°C 1000 Cycles Method 1010	DC Parameters	77	0

Note 1: Life Test Data may represent plastic D.I.P. qualification lots for the package.

Note 2: Generic Package/Process Data

Attachment #1

TABLE II. Pin combination to be tested. 1/ 2/

	Terminal A (Each pin individually connected to terminal A with the other floating)	Terminal B (The common combination of all like-named pins connected to terminal B)
1.	All pins except $V_{PS1}$ 3/	All $V_{PS1}$ pins
2.	All input and output pins	All other input-output pins

1/ Table II is restated in narrative form in 3.4 below.

2/ No connects are not to be tested.

3/ Repeat pin combination I for each named Power supply and for ground

(e.g., where  $V_{PS1}$  is  $V_{DD}$ ,  $V_{CC}$ ,  $V_{SS}$ ,  $V_{BB}$ , GND,  $+V_S$ ,  $-V_S$ ,  $V_{REF}$ , etc).

3.4 Pin combinations to be tested.

- a. Each pin individually connected to terminal A with respect to the device ground pin(s) connected to terminal B. All pins except the one being tested and the ground pin(s) shall be open.
- b. Each pin individually connected to terminal A with respect to each different set of a combination of all named power supply pins (e.g.,  $V_{SS1}$ , or  $V_{SS2}$  or  $V_{SS3}$  or  $V_{CC1}$ , or  $V_{CC2}$ ) connected to terminal B. All pins except the one being tested and the power supply pin or set of pins shall be open.
- c. Each input and each output individually connected to terminal A with respect to a combination of all the other input and output pins connected to terminal B. All pins except the input or output pin being tested and the combination of all the other input and output pins shall be open.

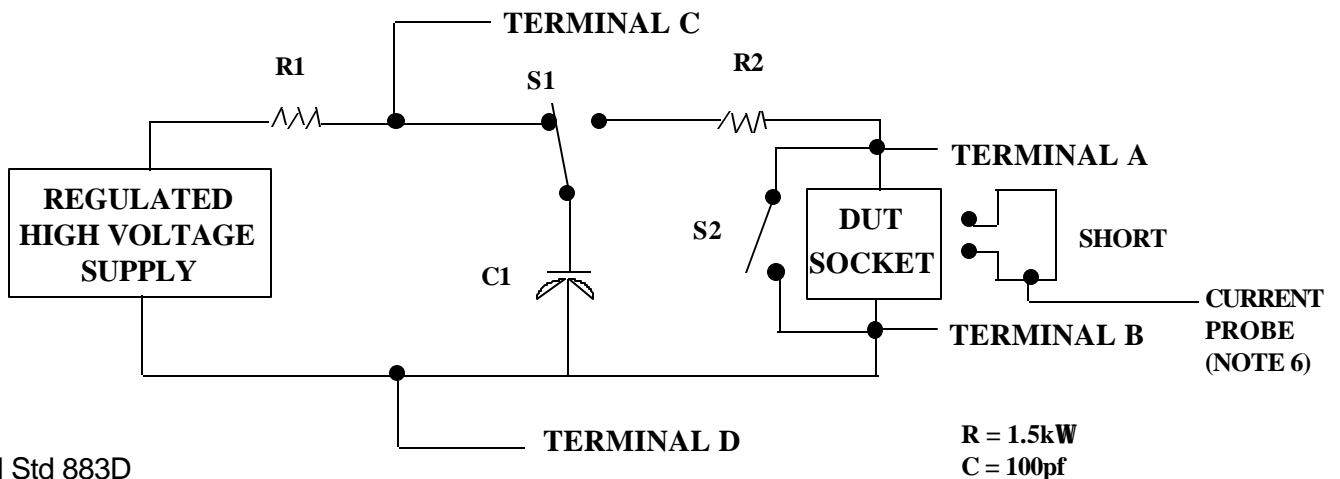

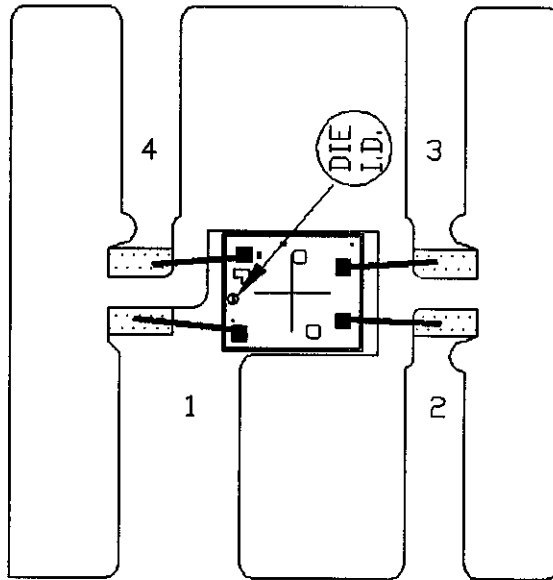

PKG.CODE: U4-1

APPROVALS

DATE



CAV./PAD SIZE:  
45X32

PKG.  
DESIGN

BUILDSHEET NUMBER:  
05-1701-0263

REV.:  
A

ONCE PER SOCKET

ONCE PER BOARD

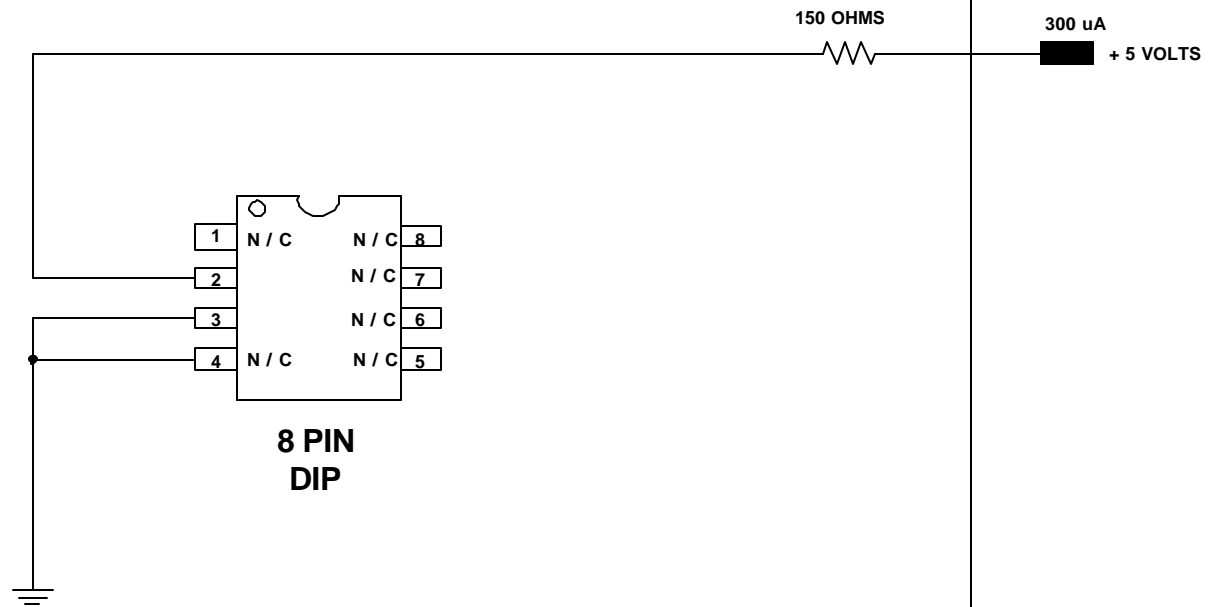

DEVICES: MAX 705/706/707/708/709/809/811/812/813/821/  
822/6314/6315/6326/6327/6328  
MAX. EXPECTED CURRENT = 300  $\mu$ A

DRAWN BY:  
NOTES: MS17 only for MAX 6326-28