

General Description

The MAX79356 evaluation kit (EV kit) demonstrates the functionality of the MAX79356 (ZENO™) flexible narrow-band OFDM powerline communication modem.

Evaluation Kit Content

- Two MAX79356 evaluation boards
- Two USB/UART audio jack type cables
- Two 15V DC adapters
- Two power cords

Benefits and Features

- Ease of Use Through Preloaded Simple-MAC Firmware and ZENO Simple-Connect GUI for Quick PHY Testing
- Full-MAC G3 Firmware and G3 PLC Connect GUI with EAP-PSK Server Available for Download
- Single Evaluation Kit Supports All Frequency Bands: CENELEC-A, FCC, and ARIB

Ordering Information appears at end of data sheet.

MAX79356 EV Kit Board

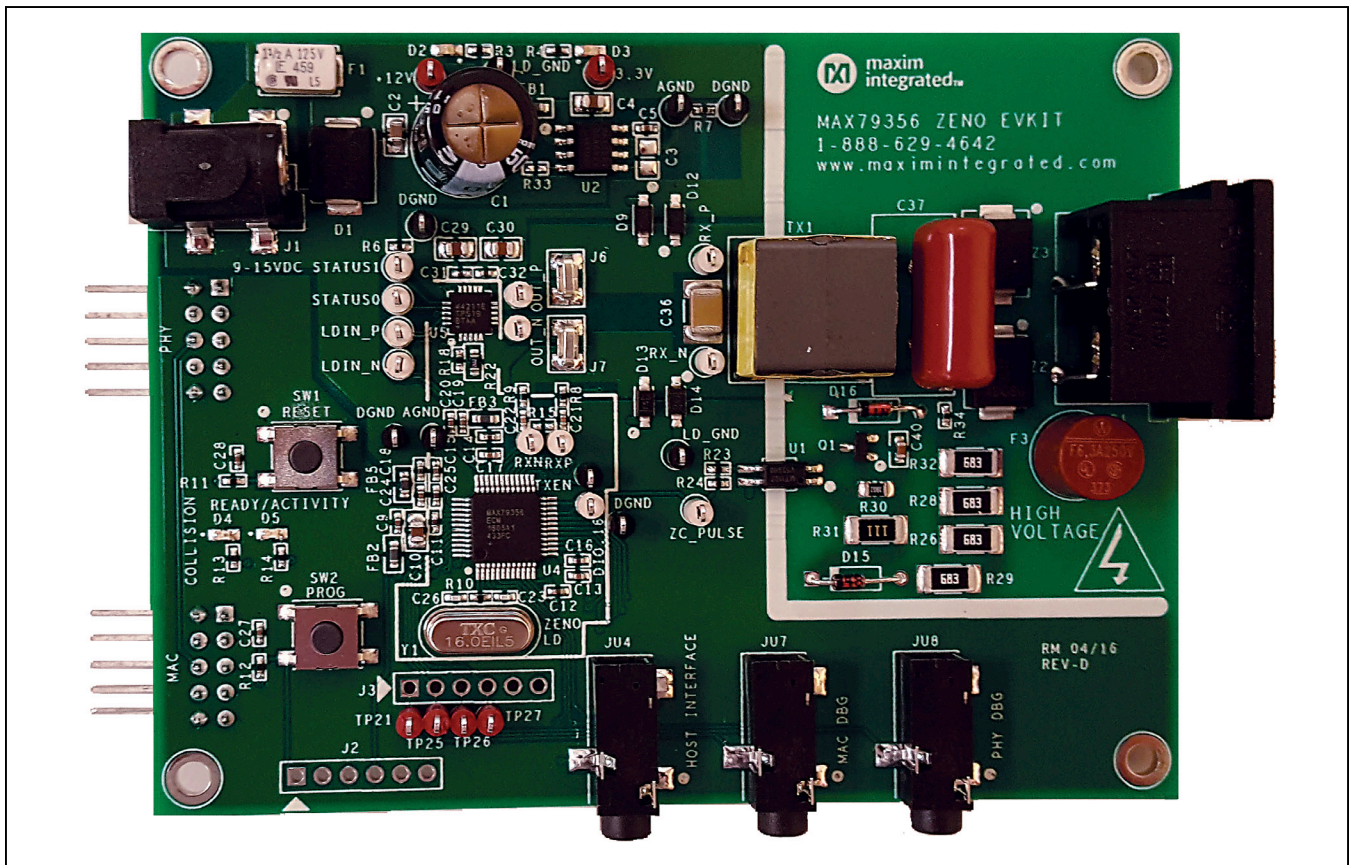

ZENO is a trademark of Maxim Integrated Products, Inc.

Safety Notes

Warning: EXERCISE CAUTION WHEN LIVE AC VOLTAGES ARE PRESENT!

Standard ESD precautions must be taken when handling electronic equipment.

Exercise extreme caution handling the hardware and connecting test equipment to the non-isolated portion of the ZENO modem board (Figure 1, highlighted in red). Ignoring the safety requirements can lead to shock, injury, and damage of the hardware.

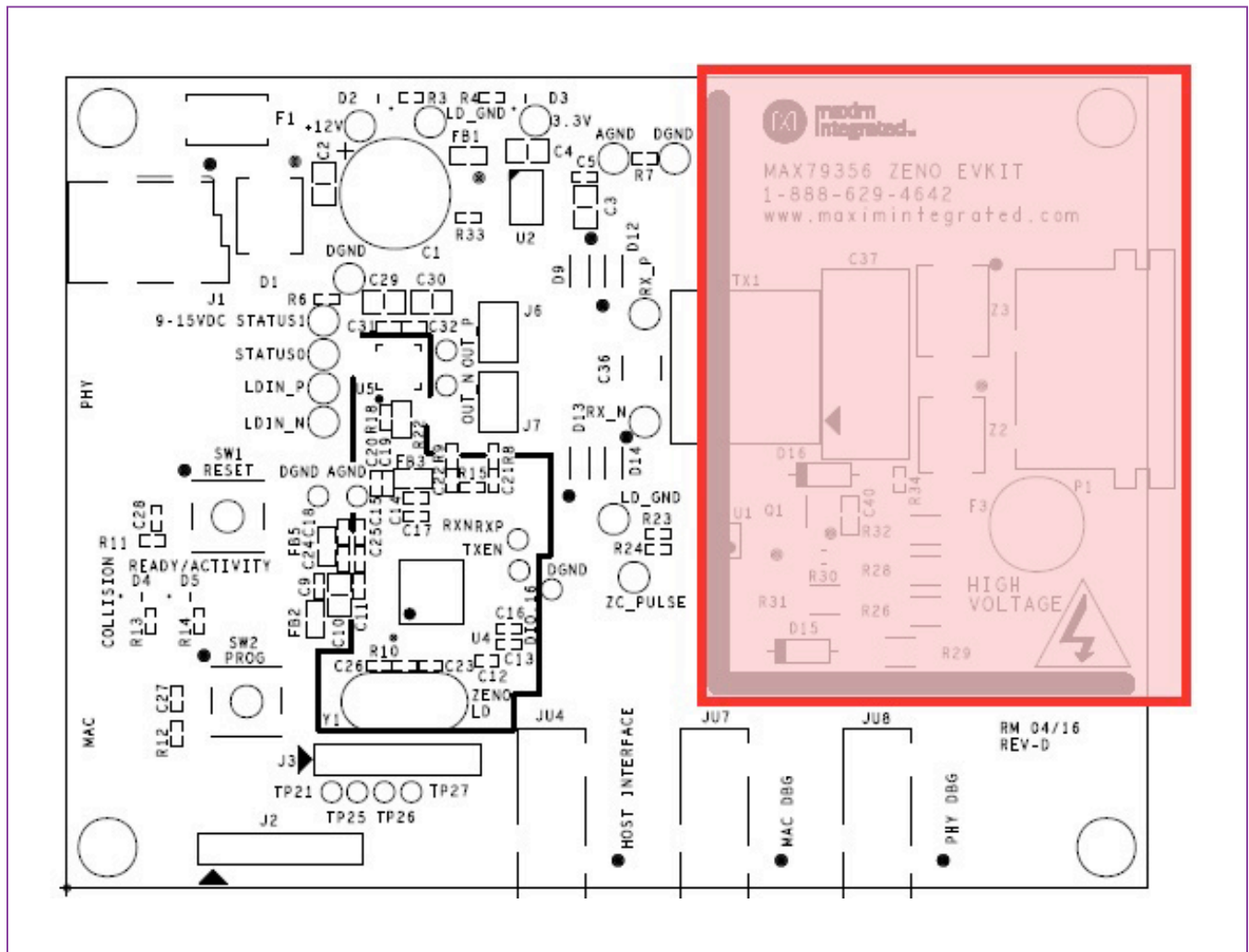

Figure 1. ZENO Board Modem

Evaluation Kit Description

The MAX79356 EV kit contains all the hardware required for point-to-point communication, utilizing Simple-MAC or Full-MAC firmware. The communication between the two modem boards can be on a powered line (up to 230V_{AC} or 300V_{DC}), or on cold wire.

Figure 2 illustrates the connection.

Evaluation Board

The EV kit contains two identical MAX79356 evaluation boards featuring a narrow-band G3-PLC modem.

Power Supply

Each evaluation board is powered by a 15V_{DC} power adapter connected to J1. A linear regulator (U2) provides the 3.3V_{DC} supply to the MAX79356 OFDM modem and the MAX44211 line driver (DVDD). The 15V_{DC} directly powers the line driver analog supply (AVDD).

The MAX79356 internal linear regulator supplies its internal 1.2V_{DC} digital logic from the 3.3V supply.

MAX79356 Operations

ZENO features two hardware UARTs (UART0, UART1). UART0 is used by the host CPU for data communication, control of the modem, and firmware updates. UART1 is used for debugging purposes.

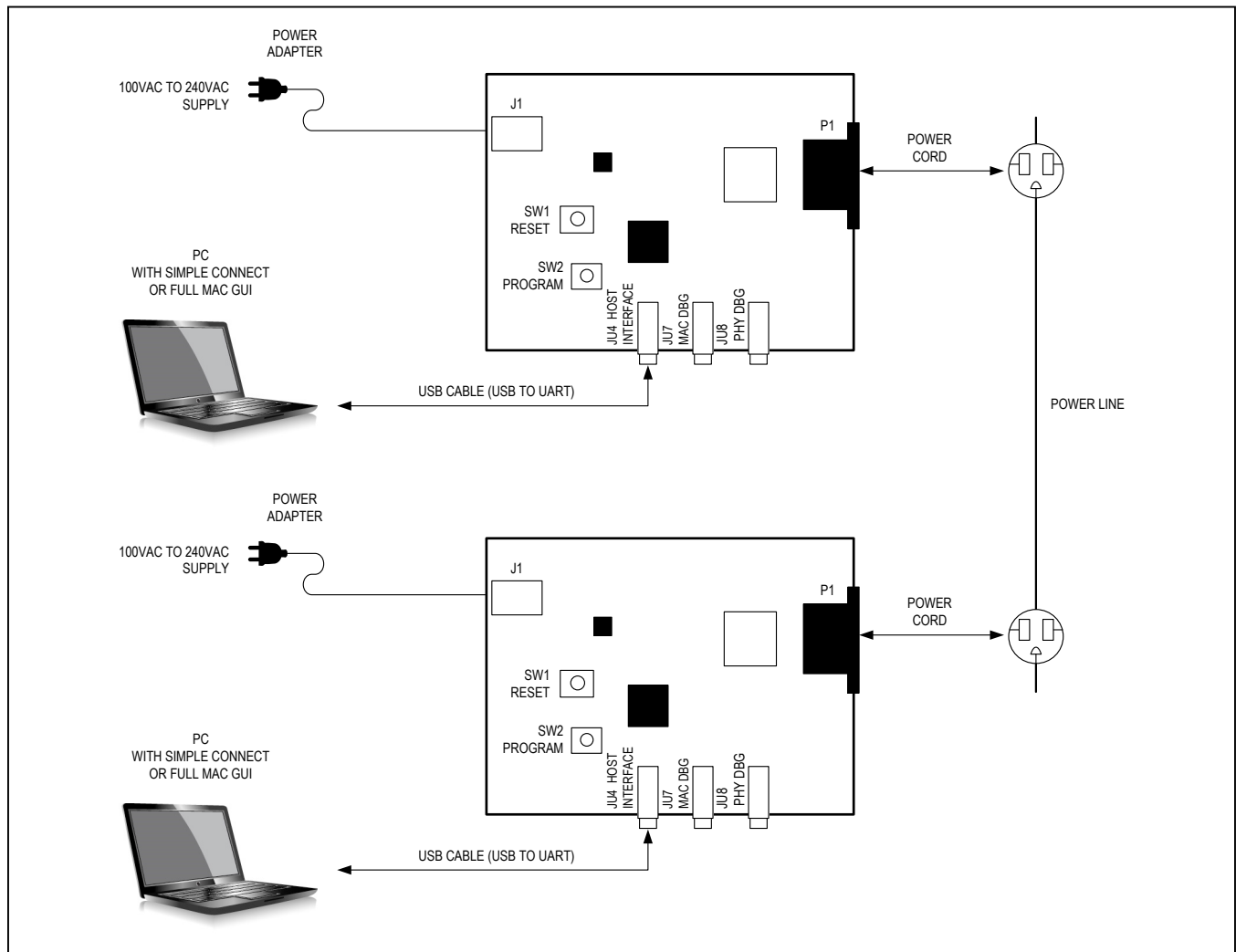

Figure 2. Connection Diagram

ZENO communicates with the host processor through a serial line interface protocol (SLIP) over the UART0 interface. The ZENO firmware supports operation at either 115,200bps or 230,400bps (depending on FW) without flow control. Refer to the ZENO G3-PLC Modem Interface Specification for details on the host communications protocol.

An SPI interface is available (master/slave) in ZENO. Refer to the data sheet or firmware release notes for availability of firmware support for SPI.

Firmware Update

The host processor can update the MAC and PHY firmware through UART0 using a specific serial loader protocol.

To go to serial loader mode, the PROG input pin is driven low and held low while the reset pin RSTN is pulsed low.

Line Driver Gain Control

The MAX79356 controls the gain inputs of MAX44211 the line driver (GAIN0 and GAIN1), the gain can be set to 6, 12, 15 and 18 according to [Table 1](#).

Line Driver Status

The MAX79356 also acquires the status of the line driver, the status is also available at the test points TP15 (Status 0) and TP16 (Status 1). [Table 2](#) describes the status conditions.

Table 1. Gain Inputs

GAIN1 (G1)	GAIN0 (G0)	GAIN (V/V)
0	0	6
0	1	12
1	0	15
1	1	18

Table 2. Status Conditions

STATUS 1	STATUS 0	CONDITION
0	0	Overtemperature Shutdown Active
0	1	High Temperature Warning Active
1	0	Overcurrent Active
1	1	Normal Operation

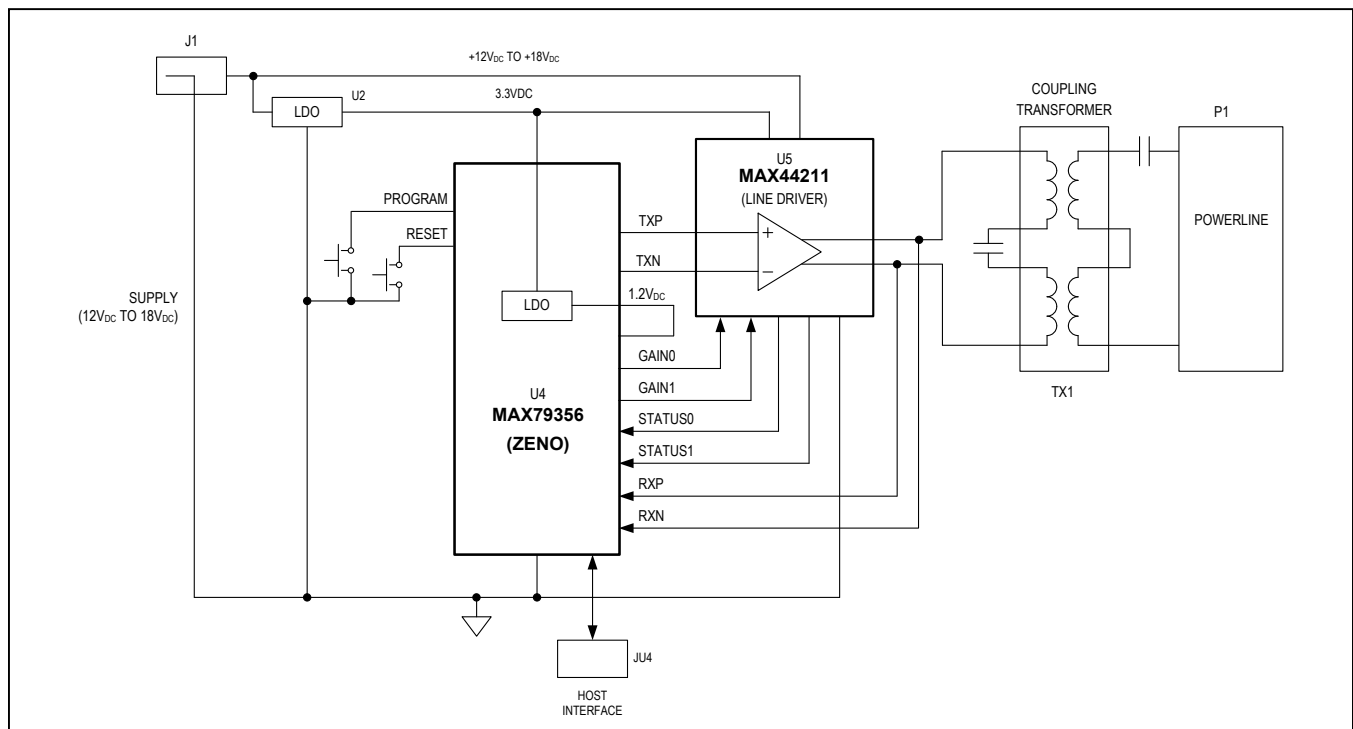

Figure 3. MAX79356 EV Kit Block Diagram

MAX44211 Line Driver

The evaluation board includes the MAX44211 power amplifier (line driver) that drives the coupling transformer. The MAX44211 provides two digital inputs for the gain selection (GAIN0 and GAIN1) controlled by the MAX79356. The MAX44211 also provides two digital outputs signaling the status of the driver (temperature and current alarms and shutdowns).

The MAX44211 provides an input (ISET) for setting its maximum output current. In the evaluation board, resistor R22 is connected between this input, and GND provides the current-limit setting.

The evaluation board's PCB includes a copper area for thermal dissipation. A heatsink can be added at the bottom of the PCB for additional power dissipation. A dual-side adhesive thermal strip secures the heatsink to the PCB. Figure 4 illustrates the location of the heatsink.

Zero-Crossing Detection

The evaluation board includes a zero-crossing detection circuit. The circuit is isolated from the MAX79356 through an optocoupler (U6). The zero-crossing circuit generates the pulses on the rising edge of the zero crossing of the AC input sine wave.

Coupling Circuit and Protections

The modem circuitry is coupled to the mains through the transformer (TX1) and the high-voltage coupling capacitor (C37). The transformer provides both signal coupling (Tx and Rx) and galvanic isolation, while the capacitor provides DC blocking and attenuation at low frequencies.

There are three main protections in the coupling circuit. The line driver is protected by four Schottky diodes. The diodes are clamping overvoltage kickbacks from the TX1 transformer. Diode Z3 is a low-voltage TVS placed between the TX1 transformer and the coupling capacitor. The main function of this diode is to clamp any overvoltage resulting from high dV/dt on the AC mains (i.e., caused by interruptions of the AC mains). Diode Z2 is a high-voltage TVS. This diode mainly protects from high-voltage transients on the mains.

Note: While diode Z2 protects the input circuitry (zero-crossing detection and coupling) against high-voltage transients, it does not guarantee the circuit to be protected as per IEC 61000-4-5 Standard. The fuse (F3) protects the input circuit against overcurrent that could result from erroneous wiring or operation errors.

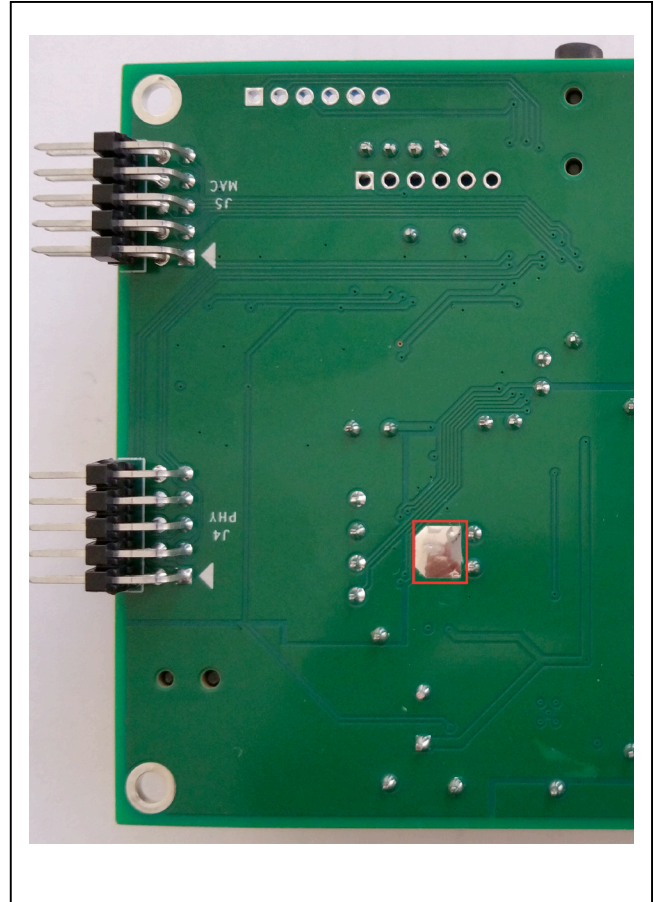

Figure 4. Location of the Heatsink

Ordering Information

PART	TYPE
MAX79356CAEVK1#	EV kit

#Denotes RoHS compliant.

MAX79356 Bill of Materials

QTY	DESIGNATOR	DESCRIPTION	MANUFACTURER	MANUFACTURER P/N
1	C1	330uF	Nichicon	UVZ1H331MPD
1	C2	1.0uF	Taiyo-Yuden	TMK212B7105KG-T
4	C4, C10, C29, C30	10uF	Murata	GRM21BC8YA106KE11L
1	C5	4.7uF	TDK	GRM21BC8YA106KE11L
5	C9, C13, C15, C17, C24	1.0uF	Taiyo-Yuden	TMK105BJ105MV-F
8	C11, C12, C14, C16, C18, C25, C31, C32	100nF	Taiyo-Yuden	GMK105BJ104KV-F
2	C19, C20	0.47uF	Murata	GRM155R61A474KE15D
2	C21, C22	1nF	Murata	GRM155R61A102KA01D
2	C23, C26	27pF	Panasonic	ECJ-0EC1H270J
2	C27, C28	220nF	Murata	GRM155R71C224KA12D
1	C36	1.5uF	Murata	GRM43DR72A155KA01L
1	C37	1uF	Panasonic	ECW-FD2W105J4
1	C40	0.68uF	TDK	CGA3E3X5R1H684M080AB
1	D1	3SMC15A TR13	On Semi	3SMC15A TR13
2	D2, D3	LED, BLUE	Kingbright	APT1608PBC/A
1	D4	LED, RED	Lite-On	LTST-C190CKT
1	D5	LED, GREEN	Lite-On	LTST-C190GKT
4	D9, D12, D13, D14	MBR230S1F	Diodes Inc.	MBR230S1F
2	D15, D16	D1N4148	Fairchild	1N4148TR
4	FB1, FB2, FB3, FB5	MMZ1608Y152B	TDK	MMZ1608Y152BTA00
1	F1	1.5A	Littelfuse	045901.5UR
1	F3	Fuse	Littelfuse	2 of A32373-ND
3	JU4, JU7, JU8	Audio Jack 3.5mm	CUI	SJ-3523-SMT-TR
1	J1	COAXIAL, POWER, RA, CTR PIN +	CUI	PJ-002AH-SMT-TR
2	J2, J3	6pin	Sullins	PBC36SAAN
2	J4, J5	RA 10Pos	Molex	901220125
2	J6, J7	TP_KEYSTONE_5019	Keystone	5019
1	P1	LP Inlet IEC-320	Qualtek	770W-X2/10
1	Q1	BC849/INF	Micro-Commercial Co	BC849C-TP

MAX79356 Bill of Materials (continued)

QTY	DESIGNATOR	DESCRIPTION	MANUFACTURER	MANUFACTURER P/N
1	R3	2K	Panasonic	ERJ-2RKF2001X
1	R4	220	Rohm	MCR01MRTF2200
4	R6, R7, R24, R34	0 Ohm	Vishay-Dale	CRCW04020000Z0ED
2	R8, R9	1K	Vishay-Dale	CRCW04021K00FKED
1	R10	1M	Vishay-Dale	CRCW04021M00FKED
3	R11, R12, R18	10K	Vishay-Dale	CRCW040210K0FKED
2	R13, R14	82	Vishay-Dale	CRCW040282R0FKED
1	R22	29.4K	Stackpole	RC0603FR-0729K4L
1	R23	20K	Vishay-Dale	CRCW040220K0FK
4	R26, R28, R29, R32	68K	Panasonic	ERJ-12ZYJ683U
1	R30	18.2K	Vishay-Dale	CRCW201018K2FKEFHP
1	R31	110	Rohm	LTR50UZPF1100
2	SW1, SW2	B3FS-1000	Omron	B3FS-1000P
6	+12V, 3.3V, TP21, TP25, TP26, TP27	RED	Keystone	5000
4	AGND, DGND, LD_GND, TXEN	BLACK	Keystone	5001
12	RXN, RXP, RX_N, RX_P, OUT_N, OUT_P, DIO.16, LDIN_N, LDIN_P, STATUS0, STATUS1, ZC_PULSE	WHITE	Keystone	5002
1	TX1	60PR970	Vitec	60PR970
1	U1	TCMT1107	Vishay	TCMT1107
1	U2	MAX16910CASA8/V+	Maxim Integrated	MAX16910CASA8/V+T
1	U4	MAX79356	Maxim Integrated	MAX79356ECM+T
1	U5	MAX44211	Maxim Integrated	MAX44211ETP+
1	Y1	16 MHz	TXC	9B-16.000MEEJ-B
1	Z2	SMCJ440CA	Littelfuse	SMCJ440CA
1	Z3	3SMC20CA	Central	3SMC20CA TR13

MAX79356 Schematics (1 of 6)

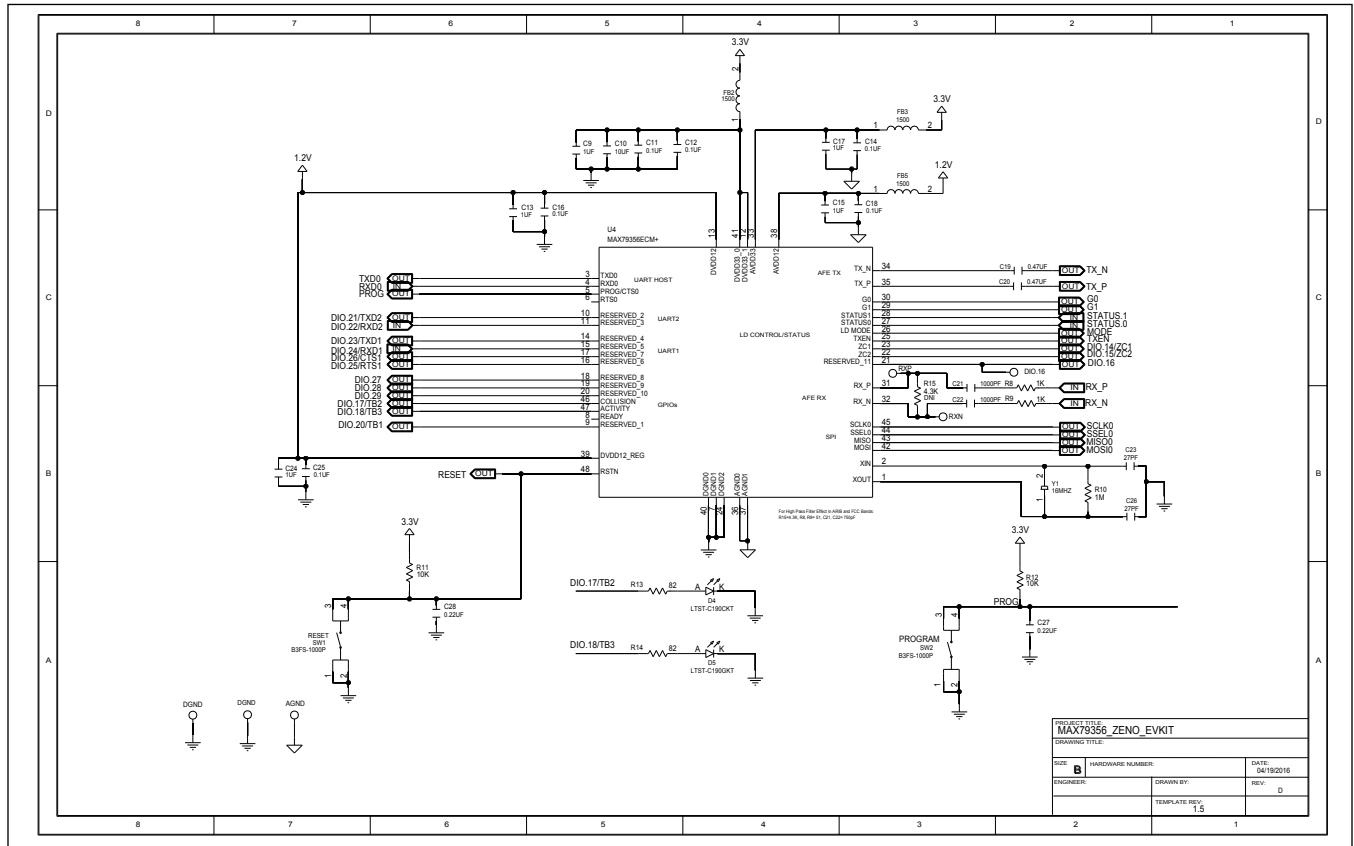

MAX79356 Schematics (2 of 6)

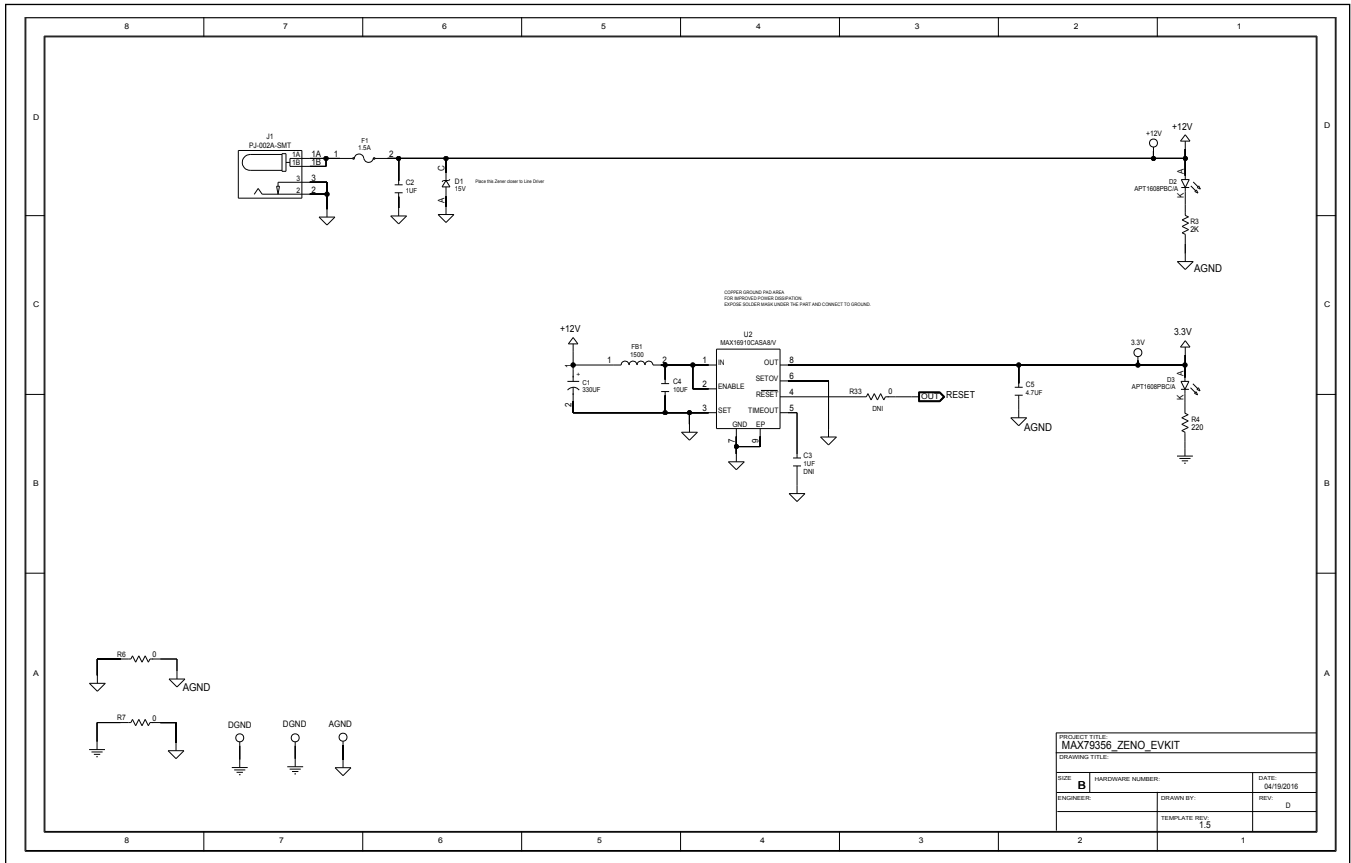

MAX79356 Schematics (3 of 6)

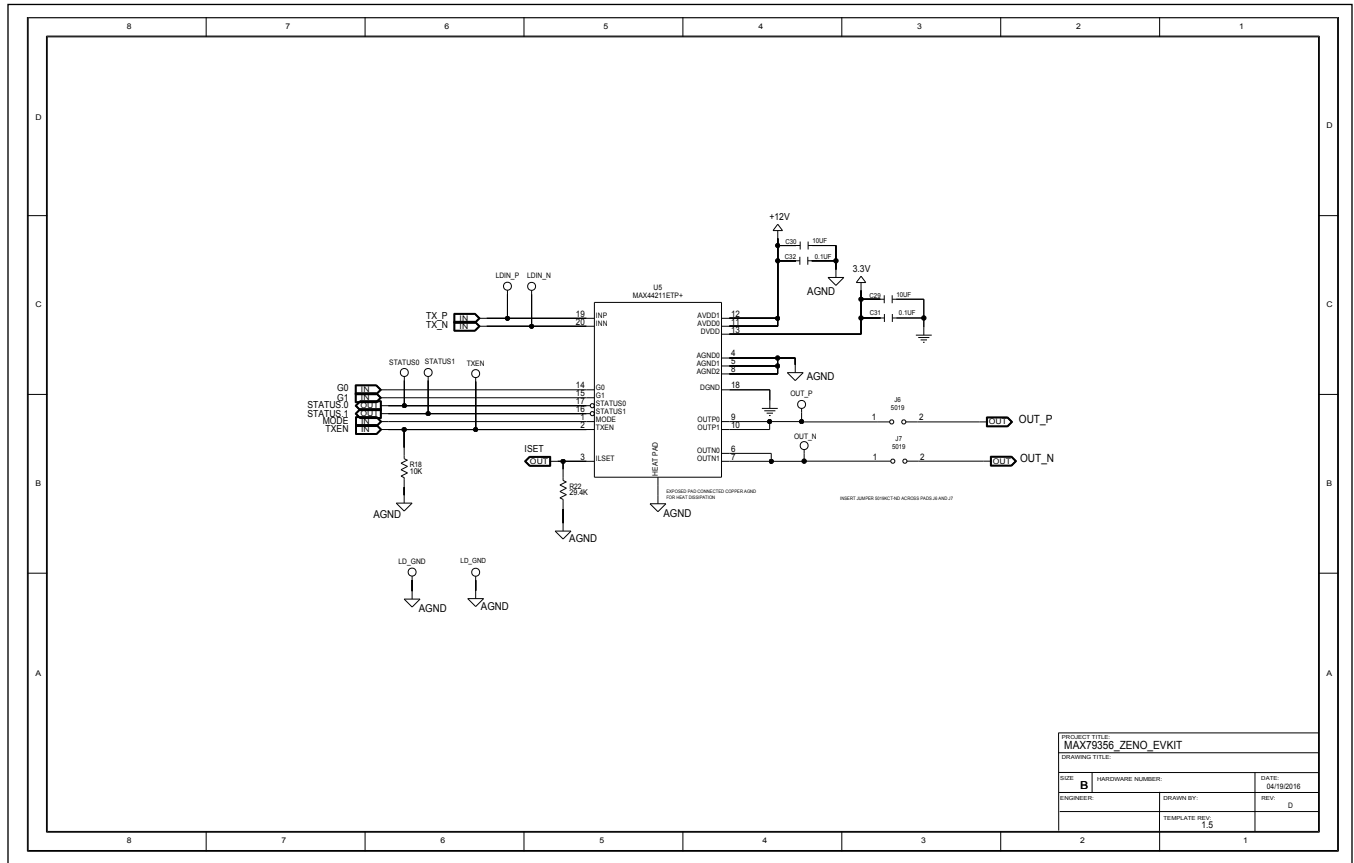

MAX79356 Schematics (4 of 6)

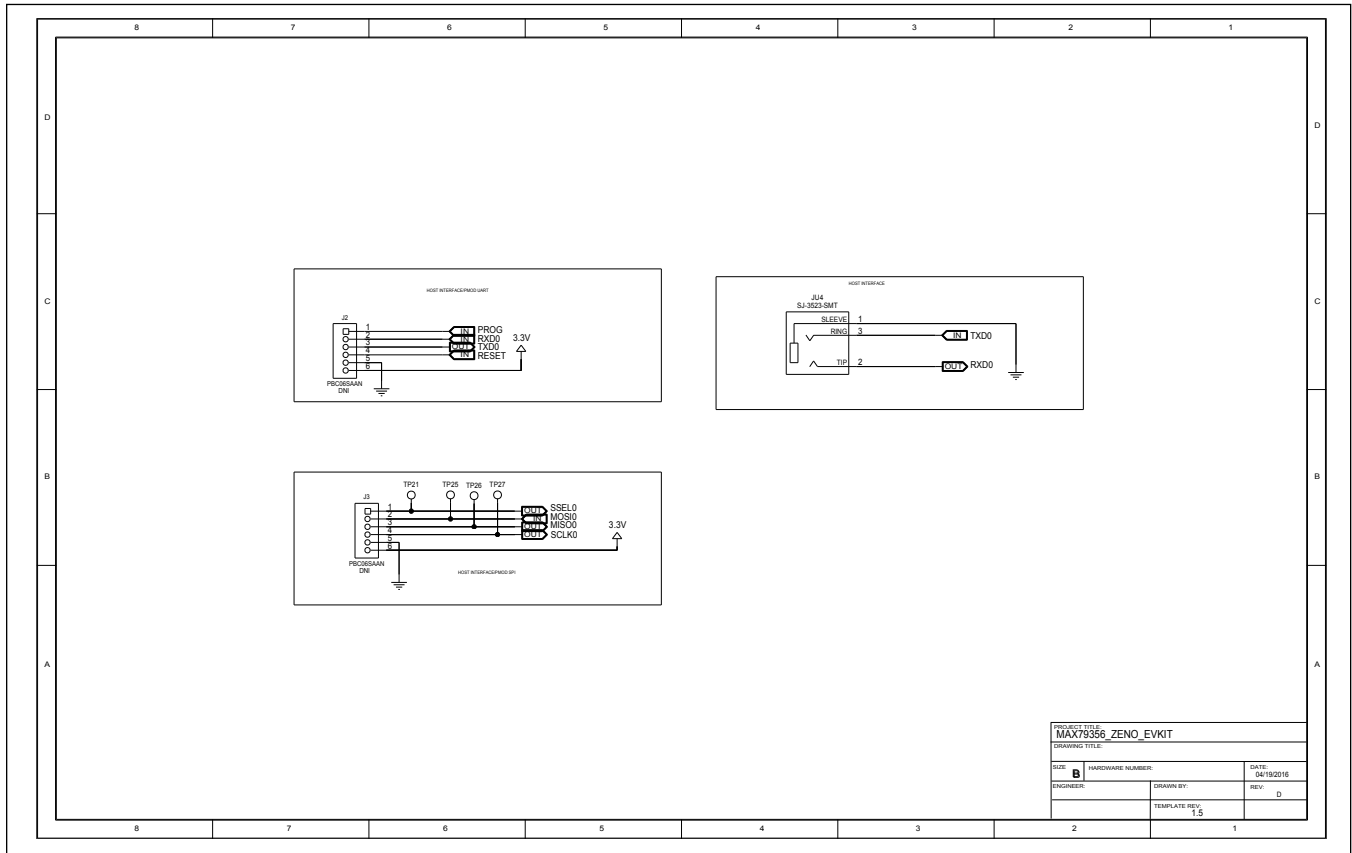

MAX79356 Schematics (5 of 6)

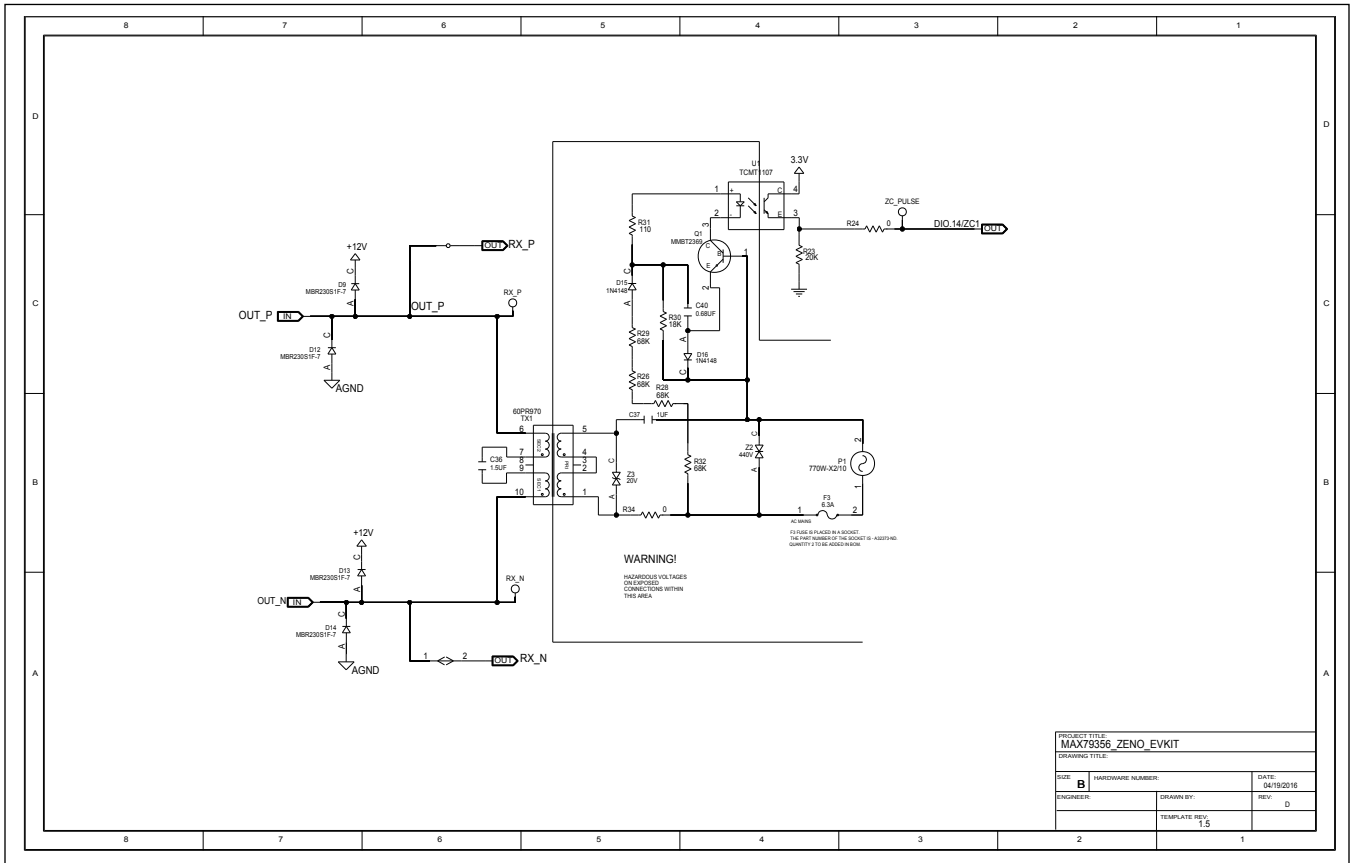

MAX79356 Schematics (6 of 6)

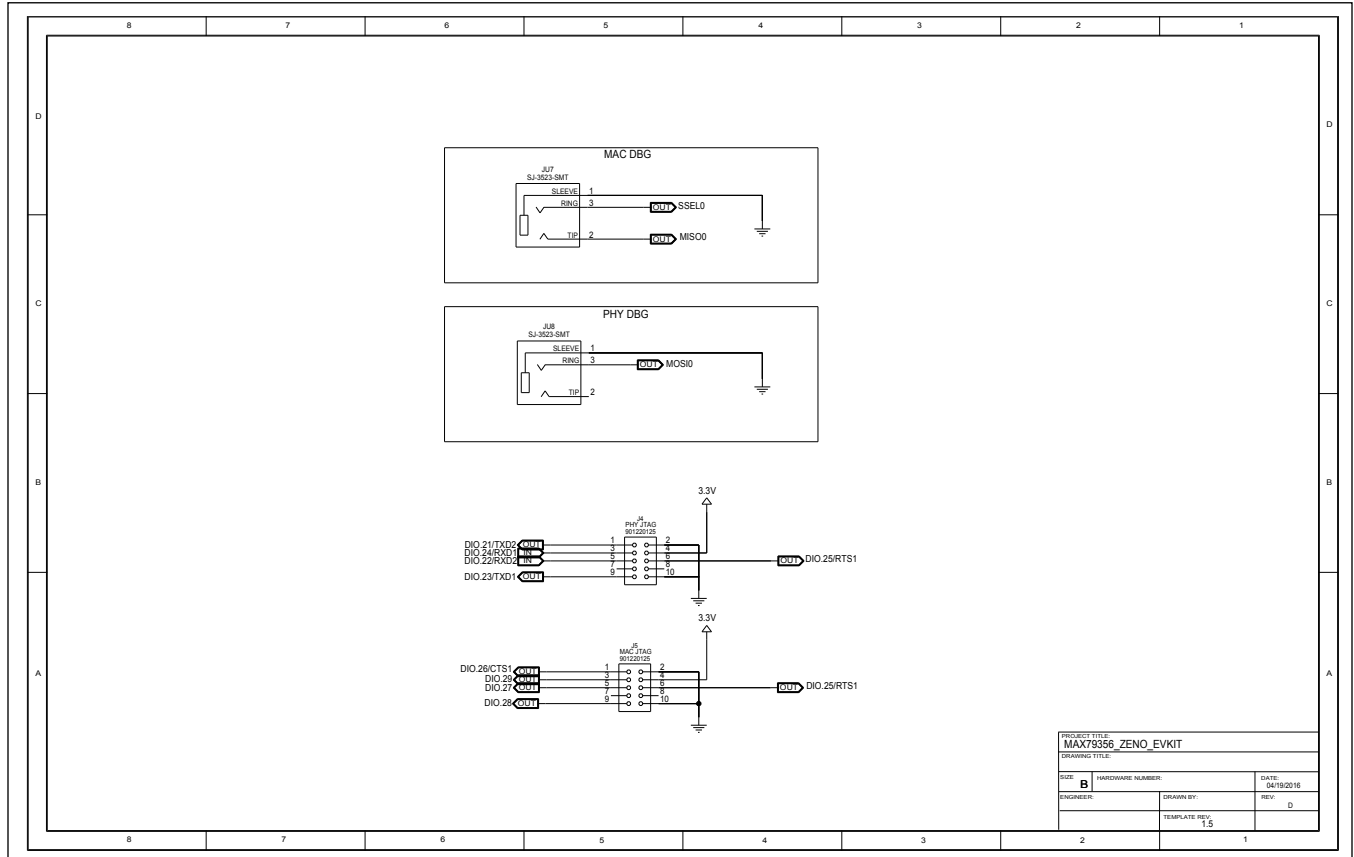

Revision History

REVISION NUMBER	REVISION DATE	DESCRIPTION	PAGES CHANGED
0	8/16	Initial release	—

For pricing, delivery, and ordering information, please contact Maxim Direct at 1-888-629-4642, or visit Maxim Integrated's website at www.maximintegrated.com.

Maxim Integrated cannot assume responsibility for use of any circuitry other than circuitry entirely embodied in a Maxim Integrated product. No circuit patent licenses are implied. Maxim Integrated reserves the right to change the circuitry and specifications without notice at any time.