

General Description

The MAX77596 evaluation kit (EV kit) demonstrates the MAX77596 synchronous step-down converter IC with integrated switches. The EV kit operates over a wide input range of 3.5V to 24V and can support loads up to 300mA. The EV kit comes standard with the 3.3V fixed output voltage version of the IC. It can be easily modified to evaluate the 5V fixed output version or the adjustable output voltage version.

The EV kit includes jumpers to enable or disable the device, as well as to select either forced-PWM mode (FPWM) or skip-mode operation. A RESETB test point is available to monitor the voltage quality of the converter's output.

Features

- Evaluates Both Fixed-Output and Adjustable-Output Versions (3.3V Version Is Preinstalled)
- 3.5V to 24V Input Voltage Range
- 300mA Maximum Load
- Demonstrates 1.1 μ A Quiescent Current at 14V Input
- $\overline{\text{RESET}}$ Output Test Point
- Simple Two-Layer Board Serves as a Reference Design
- Proven PCB Layout
- Fully Assembled and Tested

Ordering Information appears at end of data sheet.

Quick Start

Required Equipment

- MAX77596 EV kit
- DC power supply capable of supplying 24V, 300mA
- Variable load capable of sinking 300mA_{DC} at 3.3V
- Two voltmeters

Procedure

The EV kit is fully assembled and tested. Follow the steps below to verify board operation. Read all the steps before proceeding with step 1.

- 1) Verify that the IC is enabled by installing a shunt on pins 1-2 on jumper J1.
- 2) Verify that IC is operating in skip mode by installing a shunt on pins 2-3 on jumper J2.
- 3) Set the DC power supply to 0V.
- 4) Set the variable load to 0mA.
- 5) Connect the positive and negative terminals of the power supply to the VIN and GND1 test pads, respectively.
- 6) Connect terminals of the variable load to the VOUT and GND2 test pads. Observe the positive and negative polarity requirements of the variable load, if there are any (VOUT is positive and GND2 is negative).
- 7) Attach a voltmeter across the VOUT and GND2 test pads.
- 8) Attach a voltmeter across the RESETB and GND2 test pads.
- 9) Ramp the DC power-supply voltage from 0 to 12V.
- 10) Verify that the voltmeter connected to VOUT measures approximately 3.3V.
- 11) Verify that the voltmeter connected to RESETB measures approximately 5V.
- 12) Enable the variable load and ramp the load current from 0mA to 300mA.
- 13) Repeat steps 10 and 11.

Detailed Description of Hardware

The MAX77596 EV kit is a fully assembled and tested circuit board to evaluate the performance of the MAX77596 step-down converter IC. The EV kit operates over a 3.5V to 24V input voltage range, while consuming only 1.1µA of quiescent current at 14V_{IN} and 0mA load (fixed-output voltage version).

The EV kit can be configured to operate in forced-PWM mode (FPWM) or low-quiescent current skip mode using jumper J2. The IC can be enabled or disabled using jumper J1. The RESETB test point connects to the IC's RESET output, which monitors output-voltage quality. Refer to the MAX77596 IC data sheet for more information on the IC.

Configuring the Output Voltage (V_{OUT})

The EV kit comes standard with the fixed 3.3V output version, but can easily be modified to evaluate the adjustable-output version of the device or the 5V fixed version.

To evaluate the 5V fixed output voltage version, replace U1 with the MAX77596ETBA+ and leave the rest of the board unchanged.

To evaluate the adjustable-output voltage version, replace U1 with the MAX77596ETBC+ and remove the 0Ω resistor on R4. The output voltage of the adjustable version can be set between 1V and 10V by populating resistors R3 and R4. Choose R3 to be less than or equal to 100kΩ. Then calculate R4 for the desired V_{OUT} with the following equation:

$$R4 = R3 \times [(V_{OUT}/V_{FB}) - 1]$$

where V_{FB} = 1V.

Table 1. Enable Control (J1)

SHUNT POSITION	EN PIN	VOUT
1-2	Connected to VIN (SUP)	Enabled
2-3	Connected to GND (PGND)	Disabled
Not installed	Connected to an external source	Enabled with logic-high Disabled with logic-low

The feed-forward capacitor (C8) is already installed for use with the external feedback resistors and the adjustable version of the IC. C8 is not required for the fixed-output-voltage version. When evaluating other versions of the device, the inductor, input capacitors, and output capacitors might need to change. Refer to the *Applications Information* section in the MAX77596 IC data sheet for more information.

Enable Control

The EV kit uses jumper J1 to control the enable (EN) input. Connect EN to VIN (SUP) by shunting pins 1-2 to enable the device. Connect EN to GND by shunting pins 2-3 to disable the device. [Table 1](#) summarizes the operation of J1.

Mode Control

The EV kit uses jumper J2 to configure the IC in either forced-PWM (FPWM) mode or skip mode. Connect the MODE pin to BIAS by installing a shunt in positions 1-2 on J2 to enable FPWM mode. Connect MODE to GND by installing a shunt in positions 2-3 on J2 to enable skip mode. [Table 2](#) summarizes the operation of J2.

RESET Output

The EV kit provides a RESETB test point to monitor the status of the RESET pin. RESET becomes high impedance and is pulled to the BIAS voltage level through resistor R1 after the regulator output increases above 92% of the nominal regulated voltage. RESET goes low when the regulator output drops below 90% of the nominal regulated voltage.

Table 2. Mode Control (J2)

SHUNT POSITION	MODE PIN	MODE
1-2	Connected to BIAS	Forced-PWM mode
2-3	Connected to GND	Skip mode
Not installed	Floating	Internally pulled down to GND, skip mode

Component Suppliers

SUPPLIER	PHONE	WEBSITE
Murata Americas	800-241-6574	www.murataamericas.com
TOKO, Inc.	847-297-0070	www.toko.co.jp

Note: Indicate that you are using the MAX77596 when contacting these component suppliers.

Ordering Information

PART	TYPE
MAX77596EVKIT#	EV Kit

#Denotes RoHS compliant.

MAX77596 BOM

PART	QTY	DESCRIPTION
C1	1	4.7 μ F \pm 10%, 35V X5R ceramic capacitor (0603) Murata GRM188R6YA475KE15D
C2	1	1 μ F \pm 10%, 25V X5R ceramic capacitor (0603) Murata GRM188R61A105KA61D
C3	1	0.1 μ F \pm 10%, 10V X5R ceramic capacitor (0402) Murata GRM155R61A104KA01D
C4–C6	3	22 μ F \pm 20%, 10V X5R ceramic capacitors (0603) Murata GRM188R61A226ME15D
C8	1	5.6pF \pm 20%, 50V X5R ceramic capacitor (0603) Murata GRM1555C1H5R6BA01D
J1, J2	2	3-pin headers
L1	1	10 μ H \pm 30%, 1.4A inductor (2520) TOKO DFE252012F-100M
R1	1	100k Ω \pm 5% resistor (0402)
R3	0	Not installed, resistor (0402)
R4	1	0 Ω resistor (0402)
C7	0	22 μ F \pm 10%, 35V tantalum capacitor (7343), not installed
U1	1	MAX77596ETBB+ (10 TDFN-EP)
—	2	Shunts
—	1	PCB: MAX77596 EV KIT

MAX77596 Schematics

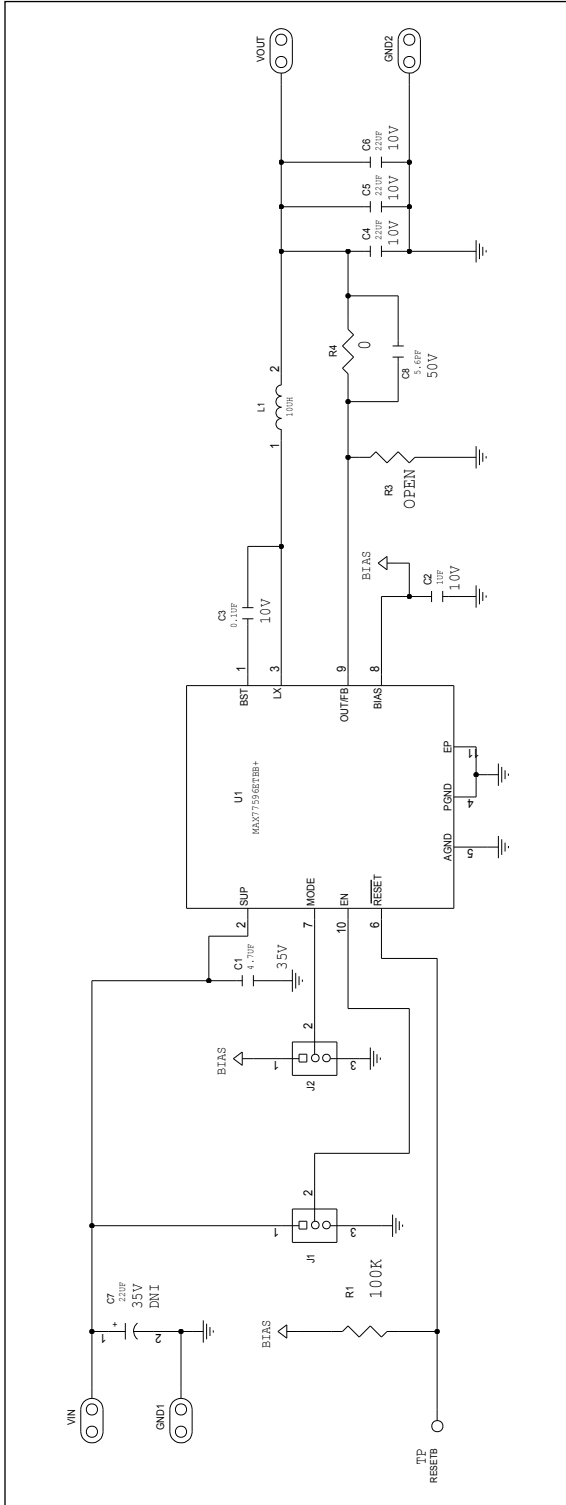

MAX77596 PCB Layout

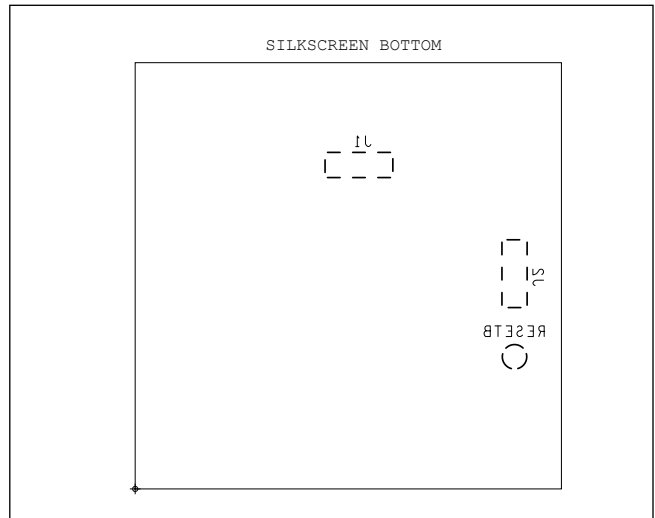
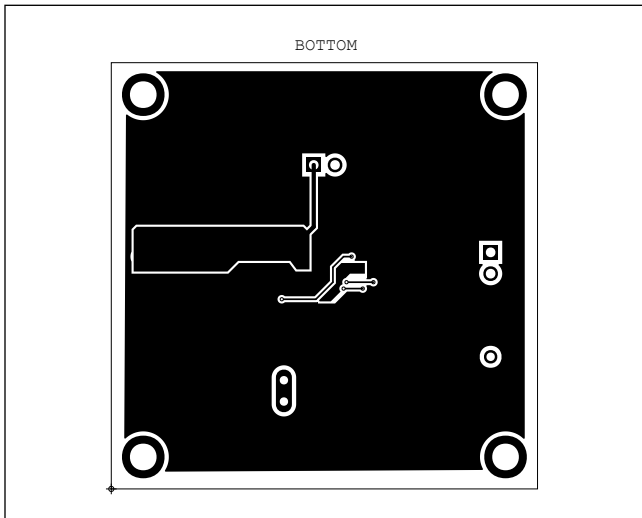
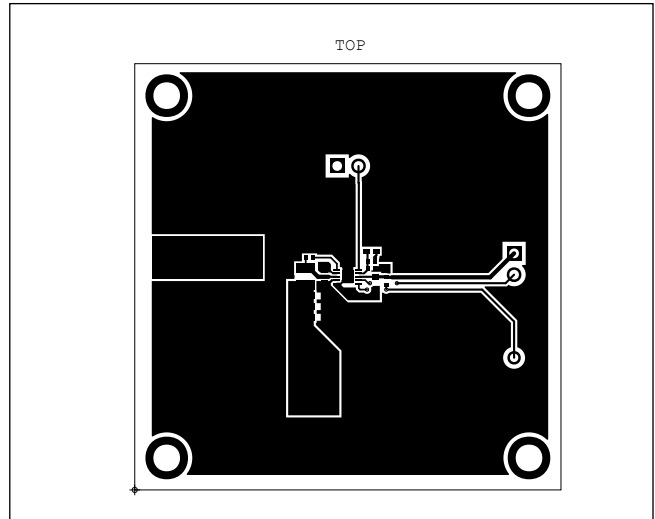
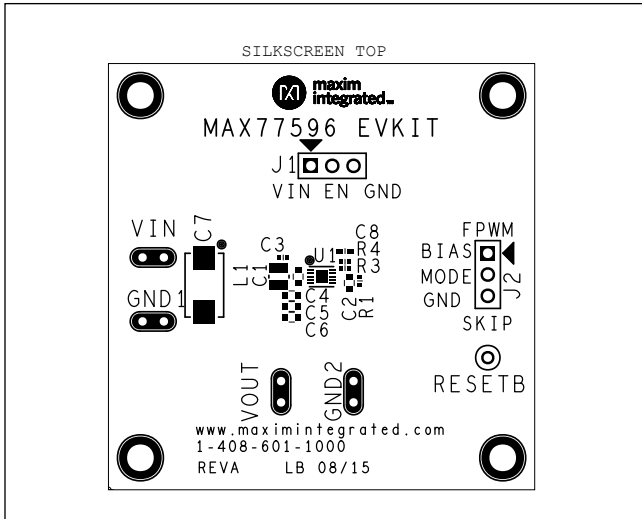

Revision History

REVISION NUMBER	REVISION DATE	DESCRIPTION	PAGES CHANGED
0	9/15	Initial release	—
1	3/16	Updated <i>General Description</i> , <i>Features</i> , and <i>Configuring the Output Voltage (V_{OUT})</i> sections	1, 2

For pricing, delivery, and ordering information, please contact Maxim Direct at 1-888-629-4642, or visit Maxim Integrated's website at www.maximintegrated.com.

Maxim Integrated cannot assume responsibility for use of any circuitry other than circuitry entirely embodied in a Maxim Integrated product. No circuit patent licenses are implied. Maxim Integrated reserves the right to change the circuitry and specifications without notice at any time.