



4-Pin SC70 Microprocessor Reset Circuits with Manual Reset Input

General Description

The MAX6711/MAX6712/MAX6713 are microprocessor (μ P) supervisory circuits used to monitor the power supplies in μ P and digital systems. They provide excellent circuit reliability and low cost by eliminating external components and adjustments when used with +5.0V, +3.3V, +3.0V, or +2.5V-powered circuits. They also provide a debounced manual reset input.

These circuits assert a reset signal whenever the V_{CC} supply voltage declines below a preset threshold or whenever manual reset is asserted. Reset remains asserted for at least 140ms after V_{CC} has risen above the reset threshold or when manual reset is deasserted. Reset thresholds suitable for operation with a variety of supply voltages are available.

The MAX6713 has an open-drain output stage, while the MAX6711/MAX6712 have push-pull outputs. The MAX6713's open-drain $\overline{\text{RESET}}$ output requires a pull-up resistor that can be connected to a voltage higher than V_{CC} . The MAX6711/MAX6713 have an active-low reset output, while the MAX6712 has an active-high reset output. The reset comparator is designed to ignore fast transients on V_{CC} , and the outputs are guaranteed to be in the correct logic state for V_{CC} down to 1V.

Low supply current makes the MAX6711/MAX6712/MAX6713 ideal for use in portable equipment. These devices are available in a 4-pin SC70 package.

Applications

Computers
 Controllers
 Intelligent Instruments
 Critical μ P and μ C Power Monitoring
 Portable/Battery-Powered Equipment
 Automotive

Typical Operating Circuit

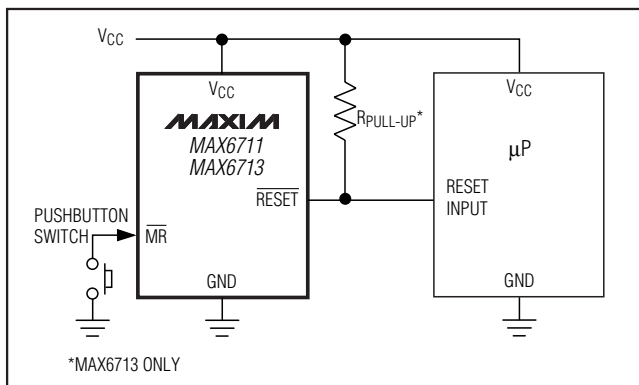

Features

- ◆ Precision Monitoring of 2.5V, 3.0V, 3.3V, and 5.0V Power-Supply Voltages
- ◆ Fully Specified Over Temperature
- ◆ Available in Three Output Configurations
 - Push-Pull $\overline{\text{RESET}}$ Output (MAX6711)
 - Push-Pull $\overline{\text{RESET}}$ Output (MAX6712)
 - Open-Drain $\overline{\text{RESET}}$ Output (MAX6713)
- ◆ 140ms min Power-On Reset Pulse Width
- ◆ Manual Reset Input
- ◆ 12 μ A Supply Current
- ◆ Guaranteed Reset Valid to $V_{CC} = +1V$
- ◆ Power-Supply Transient Immunity
- ◆ No External Components
- ◆ 4-Pin SC70 Package

Ordering Information

PART	TEMP RANGE	PIN-PACKAGE
MAX6711_EXS-T	-40°C to +125°C	4 SC70-4
MAX6711_EXS-T10	-40°C to +125°C	4 SC70-4
MAX6712_EXS-T	-40°C to +125°C	4 SC70-4
MAX6712_EXS-T10	-40°C to +125°C	4 SC70-4
MAX6713_EXS-T	-40°C to +125°C	4 SC70-4
MAX6713_EXS-T10	-40°C to +125°C	4 SC70-4

Note: These parts are offered in 2.5k or 10k reels and must be ordered in 2.5k or 10k increments. Order MAX6711_EXS-T for 2.5k reels and MAX6711_EXS-T10 for 10k reels. Insert the desired suffix letter from the Selector Guide into the blank to complete the part number.

Devices are available in both leaded and lead-free packaging. Specify lead-free by replacing "-T" with "+T" when ordering.

Selector Guide appears at end of data sheet.

Pin Configuration

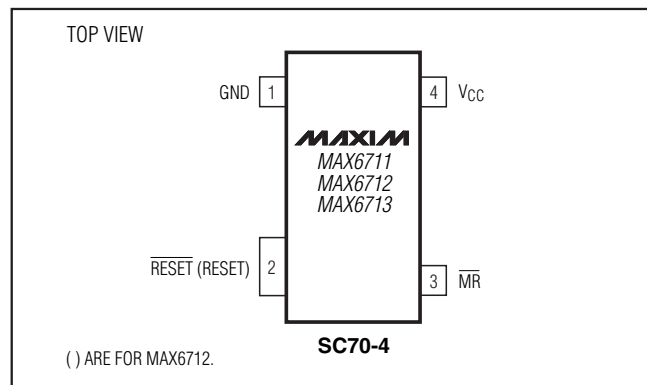

4-Pin SC70 Microprocessor Reset Circuits with Manual Reset Input

ABSOLUTE MAXIMUM RATINGS

Terminal Voltage (with respect to GND)	Rate of Rise, V_{CC}	100V/ μ s
V_{CC}	Continuous Power Dissipation ($T_A = +70^\circ\text{C}$)	4-Pin SC70 (derate 3.1mW/ $^\circ\text{C}$ above $+70^\circ\text{C}$)
RESET, $\overline{\text{RESET}}$ (push-pull)	Operating Temperature Range	-40 $^\circ\text{C}$ to +125 $^\circ\text{C}$
RESET (open drain)	Storage Temperature Range	-65 $^\circ\text{C}$ to +150 $^\circ\text{C}$
$\overline{\text{MR}}$	Lead Temperature (soldering, 10s)	+300 $^\circ\text{C}$
Input Current, V_{CC} , $\overline{\text{MR}}$		
Output Current, RESET, $\overline{\text{RESET}}$		

Stresses beyond those listed under "Absolute Maximum Ratings" may cause permanent damage to the device. These are stress ratings only, and functional operation of the device at these or any other conditions beyond those indicated in the operational sections of the specifications is not implied. Exposure to absolute maximum rating conditions for extended periods may affect device reliability.

ELECTRICAL CHARACTERISTICS

(V_{CC} = full range, $T_A = -40^\circ\text{C}$ to $+125^\circ\text{C}$, unless otherwise noted. Typical values are at $V_{CC} = +5\text{V}$ for L/M versions, $V_{CC} = +3.3\text{V}$ for T/S versions, $V_{CC} = +3\text{V}$ for R version, $V_{CC} = +2.5\text{V}$ for Z version, and $T_A = +25^\circ\text{C}$.) (Note 1)

PARAMETER	SYMBOL	CONDITIONS	MIN	TYP	MAX	UNITS			
V _{CC} Range		T _A = 0 $^\circ\text{C}$ to +70 $^\circ\text{C}$	1.0		5.5	V			
		T _A = -40 $^\circ\text{C}$ to +125 $^\circ\text{C}$	1.2		5.5				
Supply Current	I _{CC}	T _A = -40 $^\circ\text{C}$ to +85 $^\circ\text{C}$	V _{CC} < 5.5V, MAX671_L/M	16	35	μA			
			V _{CC} < 3.6V, MAX671_R/S/T/Z	12	30				
		T _A = +85 $^\circ\text{C}$ to +125 $^\circ\text{C}$	V _{CC} < 5.5V, MAX671_L/M		60				
			V _{CC} < 3.6V, MAX671_R/S/T/Z		60				
Reset Threshold	V _{TH}	MAX671_L	T _A = +25 $^\circ\text{C}$	4.56	4.63	4.70	V		
			T _A = -40 $^\circ\text{C}$ to +85 $^\circ\text{C}$	4.50		4.75			
			T _A = +85 $^\circ\text{C}$ to +125 $^\circ\text{C}$	4.44		4.82			
		MAX671_M	T _A = +25 $^\circ\text{C}$	4.31	4.38	4.45			
			T _A = -40 $^\circ\text{C}$ to +85 $^\circ\text{C}$	4.25		4.50			
			T _A = +85 $^\circ\text{C}$ to +125 $^\circ\text{C}$	4.20		4.56			
		MAX671_T	T _A = +25 $^\circ\text{C}$	3.04	3.08	3.11			
			T _A = -40 $^\circ\text{C}$ to +85 $^\circ\text{C}$	3.00		3.15			
			T _A = +85 $^\circ\text{C}$ to +125 $^\circ\text{C}$	2.95		3.21			
		MAX671_S	T _A = +25 $^\circ\text{C}$	2.89	2.93	2.96			
			T _A = -40 $^\circ\text{C}$ to +85 $^\circ\text{C}$	2.85		3.00			
			T _A = +85 $^\circ\text{C}$ to +125 $^\circ\text{C}$	2.81		3.05			
		MAX671_R	T _A = +25 $^\circ\text{C}$	2.59	2.63	2.66			
			T _A = -40 $^\circ\text{C}$ to +85 $^\circ\text{C}$	2.55		2.70			
			T _A = +85 $^\circ\text{C}$ to +125 $^\circ\text{C}$	2.52		2.74			
		MAX671_Z	T _A = +25 $^\circ\text{C}$	2.28	2.32	2.35			
			T _A = -40 $^\circ\text{C}$ to +85 $^\circ\text{C}$	2.25		2.38			
			T _A = +85 $^\circ\text{C}$ to +125 $^\circ\text{C}$	2.22		2.42			
		Reset Threshold Tempco			30				ppm/ $^\circ\text{C}$
		V _{CC} to Reset Delay (Note 2)		V _{CC} = V _{TH} to (V _{TH} - 100mV)		20			μs
		Reset Active Timeout Period		T _A = -40 $^\circ\text{C}$ to +85 $^\circ\text{C}$	140	240		460	ms
				T _A = +85 $^\circ\text{C}$ to +125 $^\circ\text{C}$	100			640	

4-Pin SC70 Microprocessor Reset Circuits with Manual Reset Input

ELECTRICAL CHARACTERISTICS (continued)

(V_{CC} = full range, T_A = -40°C to +125°C, unless otherwise noted. Typical values are at V_{CC} = +5V for L/M versions, V_{CC} = +3.3V for T/S versions, V_{CC} = +3V for R version, V_{CC} = +2.5V for Z version, and T_A = +25°C.) (Note 1)

PARAMETER	SYMBOL	CONDITIONS	MIN	TYP	MAX	UNITS
$\overline{\text{RESET}}$ Output-Voltage Low (MAX6711/MAX6713)	V _{OL}	V _{CC} = V _{TH} min, I _{SINK} = 1.2mA, MAX6711R/S/T/Z, MAX6713R/S/T/Z			0.3	V
		V _{CC} = V _{TH} min, I _{SINK} = 3.2mA, MAX6711L/M, MAX6713L/M			0.4	
		V _{CC} > 1.0V, I _{SINK} = 50μA			0.3	
$\overline{\text{RESET}}$ Output-Voltage High (MAX6711)	V _{OH}	V _{CC} > V _{TH} max, I _{SOURCE} = 500μA, MAX6711R/S/T/Z	0.8 · V _{CC}			V
		V _{CC} > V _{TH} max, I _{SOURCE} = 800μA, MAX6711L/M	0.8 · V _{CC}			
RESET Output-Voltage Low (MAX6712)	V _{OL}	V _{CC} = V _{TH} max, I _{SINK} = 1.2mA, MAX6712R/S/T/Z			0.3	V
		V _{CC} = V _{TH} max, I _{SINK} = 3.2mA, MAX6712L/M			0.4	
RESET Output-Voltage High (MAX6712)	V _{OH}	1.8V < V _{CC} < V _{TH} min, I _{SOURCE} = 150μA	0.8 · V _{CC}			V
$\overline{\text{RESET}}$ Open-Drain Output Leakage Current		V _{CC} > V _{TH} , $\overline{\text{RESET}}$ deasserted			1	μA
$\overline{\text{MR}}$ Input Threshold	V _{IL}		0.3 · V _{CC}			V
	V _{IH}				0.7 · V _{CC}	
$\overline{\text{MR}}$ Pull-Up Resistance			10	20		kΩ
$\overline{\text{MR}}$ Minimum Pulse Width			1			μs
$\overline{\text{MR}}$ Glitch Immunity				100		ns
$\overline{\text{MR}}$ to Reset Delay				200		ns

Note 1: Production testing done at T_A = +25°C; limits over temperature guaranteed by design only.

Note 2: $\overline{\text{RESET}}$ output for MAX6711/MAX6713; RESET output for MAX6712.

4-Pin SC70 Microprocessor Reset Circuits with Manual Reset Input

Typical Operating Characteristics

(V_{CC} = full range, T_A = -40°C to $+125^{\circ}\text{C}$, unless otherwise noted. Typical values are at V_{CC} = +5V for L/M versions, V_{CC} = +3.3V for T/S versions, V_{CC} = +3V for R version, V_{CC} = +2.5V for Z version, and T_A = $+25^{\circ}\text{C}$.)

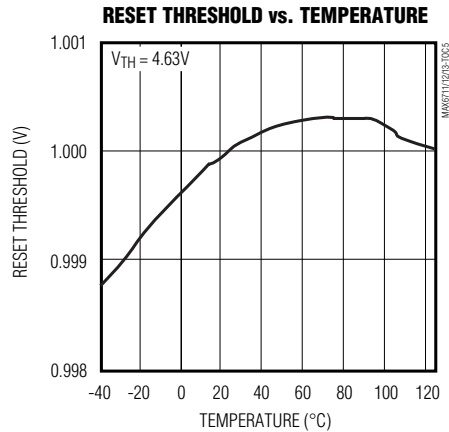
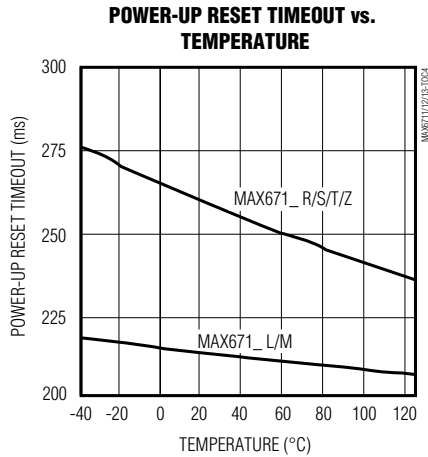
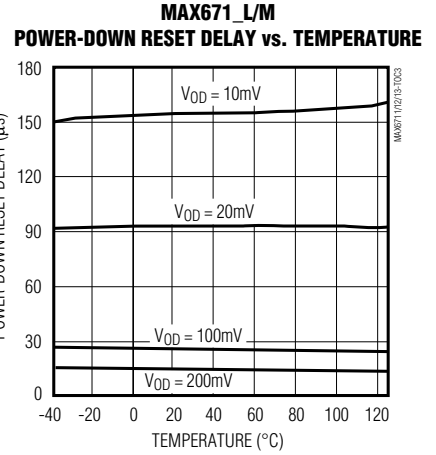
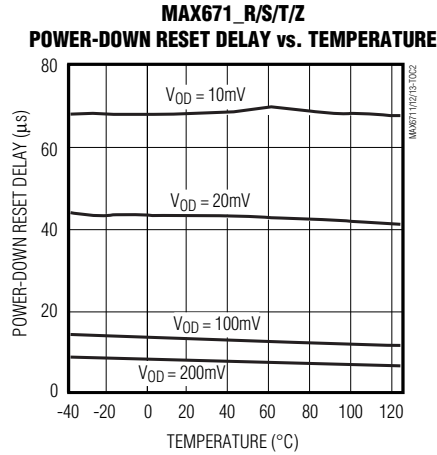
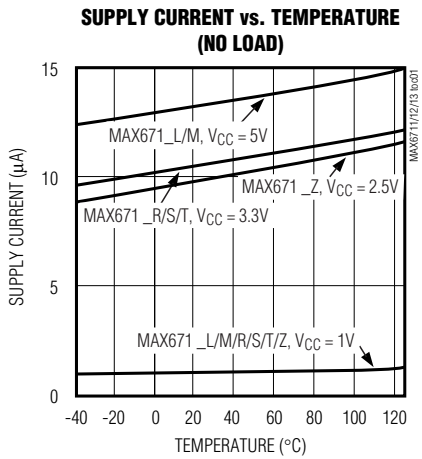

4-Pin SC70 Microprocessor Reset Circuits with Manual Reset Input

Pin Description

PIN	NAME	FUNCTION
1	GND	Ground
2	$\overline{\text{RESET}}$ (MAX6711/ MAX6713)	$\overline{\text{RESET}}$ output remains low while V_{CC} is below the reset threshold, and for at least 140ms after V_{CC} rises above the reset threshold.
	RESET (MAX6712)	RESET output remains high while V_{CC} is below the reset threshold, and for at least 140ms after V_{CC} rises above the reset threshold.
3	$\overline{\text{MR}}$	Manual Reset Input. RESET ($\overline{\text{RESET}}$) remains asserted as long as $\overline{\text{MR}}$ is low, and for at least 140ms after $\overline{\text{MR}}$ is deasserted. This active-low input has an internal 20k Ω (typ) pull-up resistor. It can be driven from a TTL- or CMOS-logic line, or shorted to ground with a switch. Leave open or connect to V_{CC} if unused.
4	V_{CC}	Supply Voltage (+5.0V, +3.3V, +3.0V, or +2.5V)

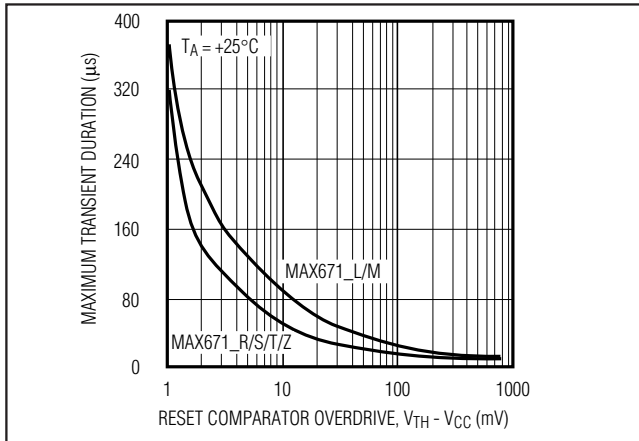

Figure 1. Maximum Transient Duration Without Causing a Reset Pulse vs. Reset Comparator Overdrive

Detailed Description

Reset Output

A microprocessor's (μP 's) reset input starts the μP in a known state. The MAX6711/MAX6712/MAX6713 assert reset to prevent code-execution errors during power-up, power-down, or brownout conditions. They assert a reset signal whenever the V_{CC} supply voltage declines below a preset threshold, keeping it asserted for at

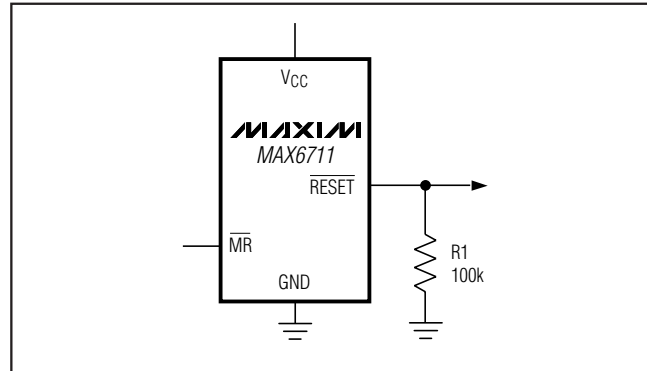

Figure 2. $\overline{\text{RESET}}$ Valid to $V_{CC} = \text{Ground}$ Circuit

least 140ms after V_{CC} has risen above the reset threshold. The MAX6713 uses an open-drain output, and the MAX6711/MAX6712 have a push-pull output stage. Connect a pull-up resistor on the MAX6713's $\overline{\text{RESET}}$ output to any supply between 0 and 6V.

Manual Reset Input

Many μP -based systems require manual reset capability, allowing the operator, a test technician, or external logic circuitry to initiate a reset. Reset remains asserted while $\overline{\text{MR}}$ is low, and for at least 140ms after $\overline{\text{MR}}$ returns high. This input has an internal 20k Ω pullup resistor, so it can be left open if it is not used. $\overline{\text{MR}}$ can be driven with TTL- or CMOS-logic levels, or with open-drain/collector outputs. To create a manual reset function, connect a normally open momentary switch from $\overline{\text{MR}}$ to ground; external debounce circuitry is not required. If $\overline{\text{MR}}$ is driven from long cables or if the device is used in a noisy environment, connecting a 0.1 μF capacitor from $\overline{\text{MR}}$ to ground provides additional noise immunity.

Applications Information

Negative-Going V_{CC} Transients

In addition to issuing a reset to the μP during power-up, power-down, and brownout conditions, the MAX6711/MAX6712/MAX6713 are relatively immune to short-duration negative-going V_{CC} transients (glitches).

Figure 1 shows typical transient duration vs. reset comparator overdrive, for which the MAX6711/MAX6712/MAX6713 do **not** generate a reset pulse. The graph was generated using a negative-going pulse applied to V_{CC} , starting 0.5V above the actual reset threshold and ending below it by the magnitude indicated (reset comparator overdrive). The graph indicates the maximum pulse width a negative-going V_{CC} transient can have without causing a reset pulse. As the magnitude of the transient increases (goes farther below the reset threshold), the

4-Pin SC70 Microprocessor Reset Circuits with Manual Reset Input

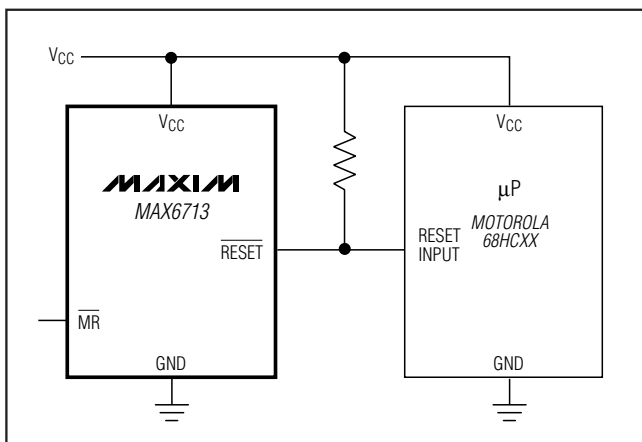

Figure 3. Interfacing to μ Ps with Bidirectional Reset I/O

maximum allowable pulse width decreases. Typically, for the MAX671_L and MAX671_M, a V_{CC} transient that goes 100mV below the reset threshold and lasts 20 μ s or less will not cause a reset pulse. A 0.1 μ F bypass capacitor mounted as close as possible to the V_{CC} pin provides additional transient immunity.

Ensuring a Valid Reset Output Down to $V_{CC} = 0$

When V_{CC} falls below 1V, the MAX6711 $\overline{\text{RESET}}$ output no longer sinks current—it becomes an open circuit. Therefore, high-impedance CMOS-logic inputs connected to $\overline{\text{RESET}}$ can drift to undetermined voltages. This presents no problem in most applications since most μ P and other circuitry is inoperative with V_{CC} below 1V. However, in applications where $\overline{\text{RESET}}$ must be valid down to 0, adding a pull-down resistor to $\overline{\text{RESET}}$ causes any stray leakage currents to flow to ground, holding $\overline{\text{RESET}}$ low (Figure 2). R_1 's value is not critical; 100k Ω is large enough not to load $\overline{\text{RESET}}$ and small enough to pull $\overline{\text{RESET}}$ to ground.

A 100k Ω pull-up resistor to V_{CC} is also recommended for the MAX6712 if $\overline{\text{RESET}}$ is required to remain valid for $V_{CC} < 1V$.

Interfacing to μ Ps with Bidirectional Reset Pins

Since the $\overline{\text{RESET}}$ output on the MAX6713 is open-drain, this device interfaces easily with μ Ps that have bidirectional reset pins, such as the Motorola 68HC11. Connecting the μ P supervisor's $\overline{\text{RESET}}$ output directly to the μ P's $\overline{\text{RESET}}$ pin with a single pull-up resistor allows either device to assert reset (Figure 3).

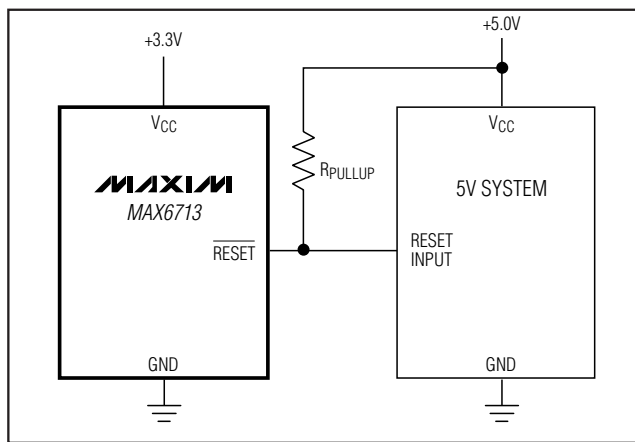

Figure 4. MAX6713 Open-Drain $\overline{\text{RESET}}$ Output Allows Use with Multiple Supplies

MAX6713 Open-Drain $\overline{\text{RESET}}$ Output Allows Use with Multiple Supplies

Generally, the pull-up connected to the MAX6713 will connect to the supply voltage that is being monitored at the IC's V_{CC} pin. However, some systems may use the open-drain output to level-shift from the monitored supply to reset circuitry powered by some other supply (Figure 4). Note that as the MAX6713's V_{CC} decreases below 1V, so does the IC's ability to sink current at $\overline{\text{RESET}}$. Also, with any pullup, $\overline{\text{RESET}}$ will be pulled high as V_{CC} decays toward 0. The voltage where this occurs depends on the pull-up resistor value and the voltage to which it is connected.

Benefits of Highly Accurate Reset Threshold

Most μ P supervisor ICs have reset threshold voltages between 5% and 10% below the value of nominal supply voltages. This ensures a reset will **not** occur within 5% of the nominal supply, but **will** occur when the supply is 10% below nominal.

When using ICs rated at only the nominal supply $\pm 5\%$, a zone of uncertainty where the supply is between 5% and 10% low, and where the reset may or may not be asserted is left.

The MAX671_L/T/Z use highly accurate circuitry to ensure that reset is asserted close to the 5% limit, and long before the supply has declined to 10% below nominal.

Chip Information

TRANSISTOR COUNT: 380

4-Pin SC70 Microprocessor Reset Circuits with Manual Reset Input

Selector Guide

PART/SUFFIX	RESET THRESHOLD (V)	OUTPUT TYPE	TOP MARK
MAX6711L	4.63	Push-Pull $\overline{\text{RESET}}$	AAB
MAX6711M	4.38	Push-Pull $\overline{\text{RESET}}$	AAC
MAX6711T	3.08	Push-Pull $\overline{\text{RESET}}$	AAD
MAX6711S	2.93	Push-Pull $\overline{\text{RESET}}$	AAE
MAX6711R	2.63	Push-Pull $\overline{\text{RESET}}$	AAF
MAX6711Z	2.32	Push-Pull $\overline{\text{RESET}}$	AAG
MAX6712L	4.63	Push-Pull RESET	AAH
MAX6712M	4.38	Push-Pull RESET	AAI
MAX6712T	3.08	Push-Pull RESET	AAJ
MAX6712S	2.93	Push-Pull RESET	AAK
MAX6712R	2.63	Push-Pull RESET	AAL
MAX6712Z	2.32	Push-Pull RESET	AAM
MAX6713L	4.63	Open-Drain $\overline{\text{RESET}}$	AAN
MAX6713M	4.38	Open-Drain $\overline{\text{RESET}}$	AAO
MAX6713T	3.08	Open-Drain $\overline{\text{RESET}}$	AAP
MAX6713S	2.93	Open-Drain $\overline{\text{RESET}}$	AAQ
MAX6713R	2.63	Open-Drain $\overline{\text{RESET}}$	AAR
MAX6713Z	2.32	Open-Drain $\overline{\text{RESET}}$	AAS

MAX6711L/M/R/S/T/Z, MAX6712L/M/R/S/T/Z, MAX6713L/M/R/S/T/Z

4-Pin SC70 Microprocessor Reset Circuits with Manual Reset Input

Package Information

(The package drawing(s) in this data sheet may not reflect the most current specifications. For the latest package outline information, go to www.maxim-ic.com/packages.)

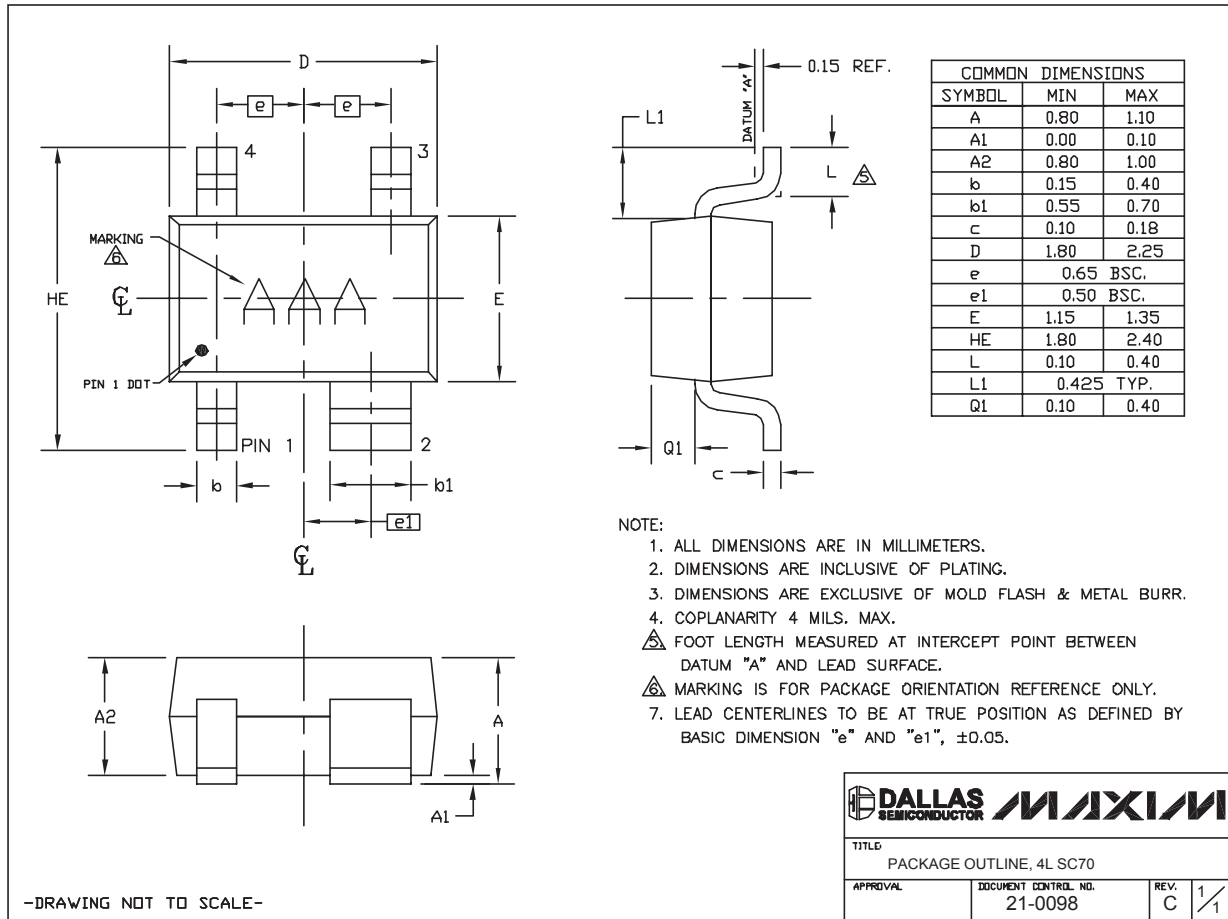

SC70, 4LEPS

Maxim cannot assume responsibility for use of any circuitry other than circuitry entirely embodied in a Maxim product. No circuit patent licenses are implied. Maxim reserves the right to change the circuitry and specifications without notice at any time.

8 Maxim Integrated Products, 120 San Gabriel Drive, Sunnyvale, CA 94086 408-737-7600