

## Dual Remote/Local Temperature Sensors and Four-Channel Voltage Monitors

## MAX6655/MAX6656

### General Description

The MAX6655/MAX6656 are precise voltage and temperature monitors. The digital thermometer reports the temperature of two remote sensors and its own die temperature. The remote sensors are diode-connected transistors—typically a low-cost, easily mounted 2N3906 PNP type—that replace conventional thermistors or thermocouples. Remote accuracy is  $\pm 1^{\circ}\text{C}$  for multiple transistor manufacturers with no calibration necessary. The remote channels can also measure the die temperature of other ICs, such as microprocessors, that contain a substrate-connected PNP with its collector grounded and its base and emitter available for temperature-sensing purposes. The temperature is digitized with 11-bit resolution.

The MAX6655/MAX6656 also measure their own supply voltage and three external voltages with 8-bit resolution. Each voltage input's sensitivity is set to give approximately 3/4-scale output code when the input voltage is at its nominal value. The MAX6655 operates at +5V supply and its second voltage monitor is 3.3V. The MAX6656 operates on a +3.3V supply and its second voltage monitor is 5V.

The 2-wire serial interface accepts standard SMBus™ Write Byte, Read Byte, Send Byte, and Receive Byte commands to program the alarm thresholds and to read data. The MAX6655/MAX6656 also provide SMBus alert response and timeout functions. The MAX6655/MAX6656 measure automatically and autonomously, with the conversion rate programmable. The adjustable rate allows the user to control the supply current.

In addition to the SMBus  $\overline{\text{ALERT}}$  output, the MAX6655/MAX6656 feature an  $\overline{\text{OVERT}}$  output, which is used as a temperature reset that remains active only while the temperature is above the maximum temperature limit. The  $\overline{\text{OVERT}}$  output is optimal for fan control or for system shutdown.

### Applications

- Notebooks
- Thin Clients
- Servers
- Workstations
- Communication Equipment
- Desktop PC

SMBus is a trademark of Intel Corp.

### Features

- Three Temperature Channels
  - Two Remote PN Junctions
  - One Local Sensor
- Four Voltage Channels
  - +12V, +5V, +3.3V, +2.5V
  - Three External Monitors
  - One Internal Supply Monitor
- 11-Bit,  $0.125^{\circ}\text{C}$  Resolution
- High Accuracy:  $\pm 1^{\circ}\text{C}$  Over  $+60^{\circ}\text{C}$  to  $+100^{\circ}\text{C}$  Temperature Range
- Programmable Under/Over-Threshold Alarms
- Programmable Power-Saving Mode
- No Calibration Required
- SMBus/I<sup>2</sup>C-Compatible Interface
- $\overline{\text{OVERT}}$  Output for Fan Control and System Shutdown

### Ordering Information

PART	TEMP RANGE	PIN-PACKAGE	PKG CODE
MAX6655MEE	-55°C to +125°C	16 QSOP	E16-5
MAX6656MEE	-55°C to +125°C	16 QSOP	E16-5

*Typical Application Circuit appears at end of data sheet.*

### Pin Configuration

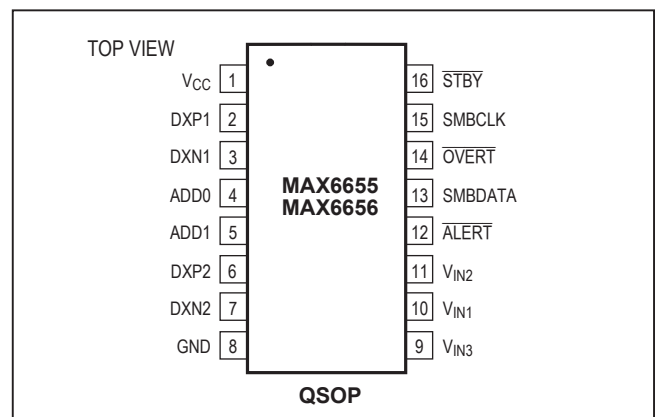

**Absolute Maximum Ratings**

V <sub>CC</sub> to GND .....	-0.3V to +6V	DXN_ Current.....	±1mA
DXN_ to GND.....	-0.3V to +0.8V	ESD Protection (all pins, Human Body Model) .....	2000V
SMBCLK, SMBDATA, ALERT, STBY, OVERT to GND .....	-0.3V to +6V	Continuous Power Dissipation (T <sub>A</sub> = +70°C) 16-Pin QSOP (derate 8.30mW/°C above +70°C) .....	667mW
V <sub>IN1</sub> to GND .....	-0.3V to +16V	Operating Temperature Range.....	-55°C to +125°C
V <sub>IN2</sub> to GND .....	-0.3V to +6V	Junction Temperature.....	+150°C
V <sub>IN3</sub> to GND .....	-0.3V to +6V	Storage Temperature Range.....	-65°C to +150°C
All Other Pins to GND .....	-0.3V to (V <sub>CC</sub> + 0.3V)	Lead Temperature (soldering, 10s) .....	+300°C
SMBDATA, ALERT, OVERT Current.....	-1mA to +50mA		

*Stresses beyond those listed under "Absolute Maximum Ratings" may cause permanent damage to the device. These are stress ratings only, and functional operation of the device at these or any other conditions beyond those indicated in the operational sections of the specifications is not implied. Exposure to absolute maximum rating conditions for extended periods may affect device reliability.*

**Electrical Characteristics**

(V<sub>CC</sub> = +3.0V to +3.6V for MAX6656, V<sub>CC</sub> = +4.5V to +5.5V for MAX6655, T<sub>A</sub> = -55°C to +125°C, unless otherwise noted. Typical values are at V<sub>CC</sub> = +3.3V for MAX6656, V<sub>CC</sub> = +5.0V for MAX6655, T<sub>A</sub> = +25°C.)

PARAMETER	SYMBOL	CONDITIONS	MIN	TYP	MAX	UNITS
Supply Range	V <sub>CC</sub>		3.0		5.5	V
Accuracy (Local Sensor)		+60°C ≤ T <sub>A</sub> ≤ +100°C			±1.5	°C
		0°C ≤ T <sub>A</sub> ≤ +125°C			±3	
Accuracy (Remote Sensor)		+60°C ≤ T <sub>RJ</sub> ≤ +100°C			±1	°C
		0°C ≤ T <sub>RJ</sub> ≤ +120°C			±3	
Temperature Measurement Resolution			0.125			°C
			11			Bits
ADC Input Impedance	Z <sub>IN</sub>	V <sub>IN1</sub> , V <sub>IN2</sub> , V <sub>IN3</sub> input resistance	100			kΩ
ADC Total Error		V <sub>IN1</sub> , V <sub>IN2</sub> , V <sub>IN3</sub> between 30% and 120% of nominal		±1	±1.5	%
V <sub>IN</sub> ADC Resolution				8		Bits
Undervoltage Lockout Threshold	UVLO	V <sub>CC</sub> input, disables A/D conversion, falling edge	2.50	2.70	2.90	V
Undervoltage Lockout Hysteresis				90		mV
Power-On Reset (POR) Threshold		V <sub>CC</sub> , falling edge	1	1.7	2.5	V
POR Threshold Hysteresis				90		mV
Standby Current		SMBus static, STBY = GND		3	10	μA
DXP and DXN Leakage Current		In standby mode			2	μA
Average Operating Current		Continuous temperature mode		550	1000	μA
Conversion Time for Single Temperature Measurement	t <sub>CON</sub>	From stop bit to conversion completed	95	125	155	ms
Monitoring Cycle Time	t <sub>MONI</sub>	Total of 3 temperature plus 4 voltage measurements		625		ms

**Electrical Characteristics (continued)**

( $V_{CC} = +3.0V$  to  $+3.6V$  for MAX6656,  $V_{CC} = +4.5V$  to  $+5.5V$  for MAX6655,  $T_A = -55^{\circ}C$  to  $+125^{\circ}C$ , unless otherwise noted. Typical values are at  $V_{CC} = +3.3V$  for MAX6656,  $V_{CC} = +5.0V$  for MAX6655,  $T_A = +25^{\circ}C$ .)

PARAMETER	SYMBOL	CONDITIONS	MIN	TYP	MAX	UNITS
Remote Junction Current (DXP, DXN)		High level	80	100	140	$\mu A$
		Low level	8	10	14	
<b>SMBus INTERFACE (SMBCLK, SMBDATA, STBY)</b>						
Logic Input Low Voltage	$V_{IL}$	$V_{CC} = +3.0V$ to $+5.5V$			0.8	V
Logic Input High Voltage	$V_{IH}$	$V_{CC} = +3.0V$	2.1			V
		$V_{CC} = +5.5V$	2.6			
Input Leakage Current	$I_{LEAK}$	$V_{IN} = GND$ or $V_{CC}$			$\pm 1$	$\mu A$
Output Low Sink Current	$I_{OL}$	$V_{OL} = +0.6V$			6	mA
Input Capacitance	$C_{IN}$			5		pF
SMBus Timeout		SMBCLK or SMBDATA time low for reset	30	35	60	ms
<b>ALERT, OVERT</b>						
Output Low Sink Current		$V_{OL} = +0.6V$			6	mA
Output High Leakage Current		$V_{OH} = +5.5V$			1	$\mu A$
<b>SMBus TIMING</b>						
Serial Clock Frequency	$f_{SCL}$				400	kHz
Bus Free Time Between STOP and START Condition	$t_{BUF}$		4.7			$\mu s$
START Condition Setup Time			4.7			$\mu s$
Repeat START Condition Setup Time	$t_{SU:STA}$	90% to 90%	50			ns
START Condition Hold Time	$t_{HD:STA}$	10% of SMBDATA to 90% of SMBCLK	4			$\mu s$
STOP Condition Setup Time	$t_{SU:STO}$	90% of SMBCLK to 10% of SMBDATA	4			$\mu s$
Clock Low Period	$t_{LOW}$	10% to 10%		4.7		$\mu s$
Clock High Period	$t_{HIGH}$	90% to 90%	4			$\mu s$
Data Setup Time	$t_{SU:DAT}$	90% of SMBDATA to 10% of SMBCLK	250			ns
Data Hold Time	$t_{HD:DAT}$	(Note 1)	0			$\mu s$
Receive SMBCLK/SMBDATA Rise Time	$t_R$				1	$\mu s$
Receive SMBCLK/SMBDATA Fall Time	$t_F$				300	ns
Pulse Width of Spike Suppressed	$t_{SP}$		0		50	ns

Typical Operating Characteristics

(TA = +25°C, unless otherwise noted.)

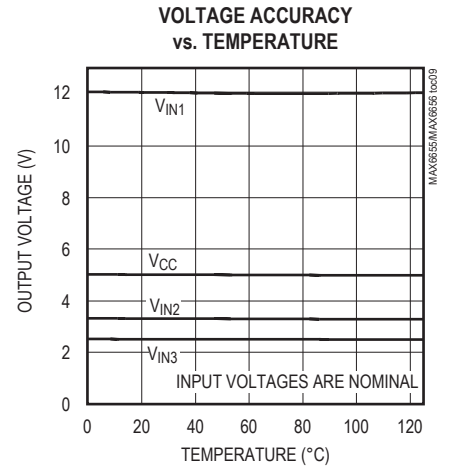
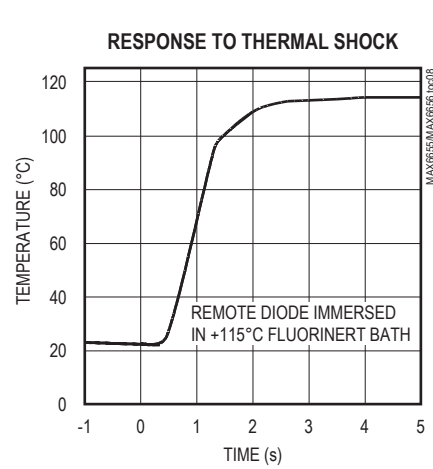
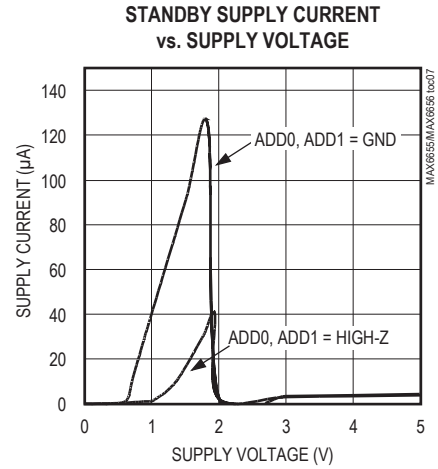
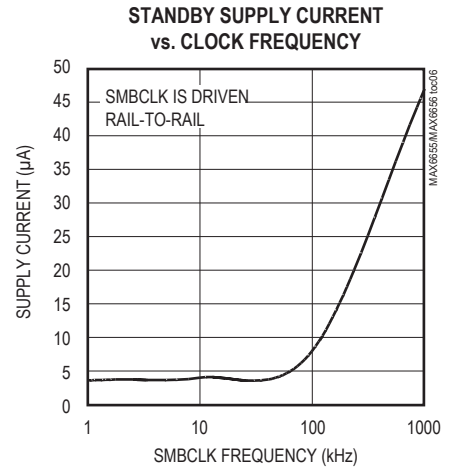
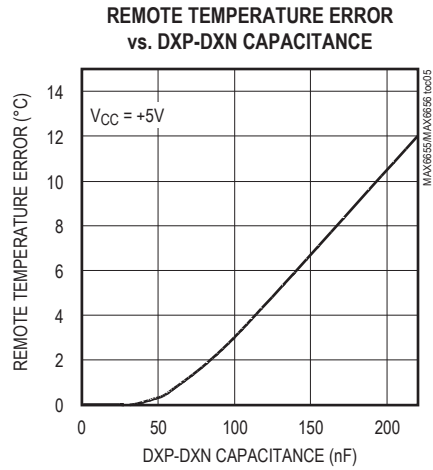
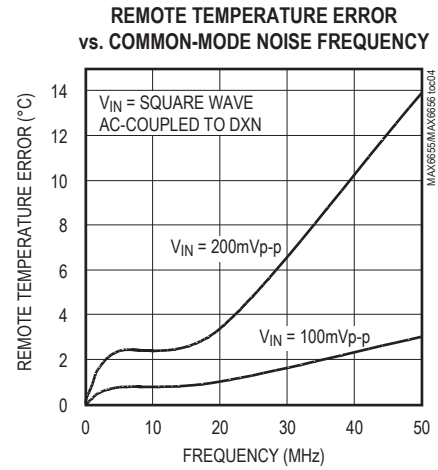
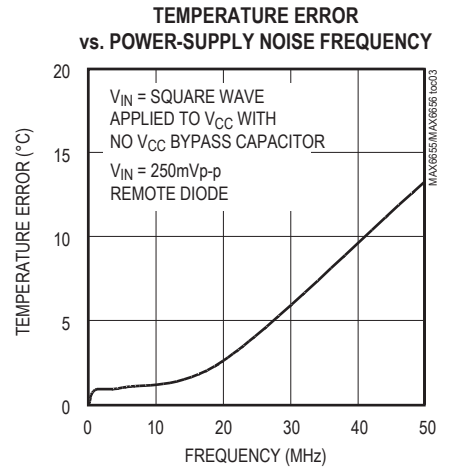
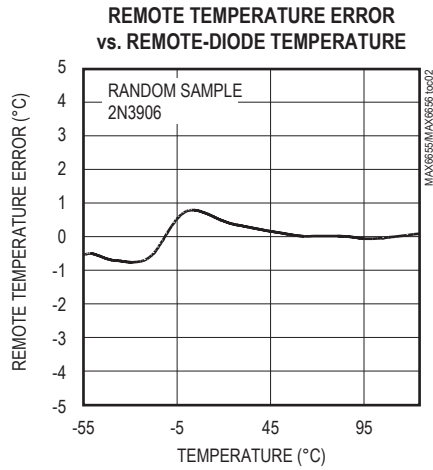
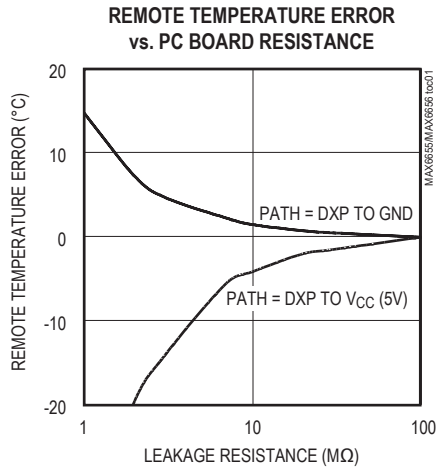

## Pin Description

PIN	NAME	FUNCTION
1	V <sub>CC</sub>	Supply Voltage. +5V for MAX6655; +3.3V for MAX6656. Bypass V <sub>CC</sub> to GND with a 0.1μF capacitor.
2	DXP1	External Diode 1 Positive Connection. DXP1 is the combined current source and ADC positive input for remote-diode 1. If a remote-sensing junction is not used, connect DXP1 to DXN1.
3	DXN1	External Diode 1 Negative Connection. DXN1 is the combined current sink and ADC negative input for remote-diode 1. DXN1 is normally biased to a diode voltage above ground.
4	ADD0	SMBus Slave Address Select Input. ADD0 and ADD1 are sampled upon power-up. Table 5 is the truth table.
5	ADD1	SMBus Slave Address Select Input. ADD0 and ADD1 are sampled upon power-up.
6	DXP2	External Diode 2 Positive Connection. DXP2 is the combined current source and ADC positive input for remote-diode 2. If a remote-sensing junction is not used, connect DXP2 to DXN2.
7	DXN2	External Diode 2 Negative Connection. DXN2 is the combined current sink and ADC negative input for remote-diode 2. DXN2 is normally biased to a diode voltage above ground.
8	GND	Ground
9	V <sub>IN3</sub>	External Voltage Monitor 3. V <sub>IN3</sub> is typically used to monitor +2.5V supplies.
10	V <sub>IN1</sub>	External Voltage Monitor 1. V <sub>IN1</sub> is typically used to monitor +12V supplies.
11	V <sub>IN2</sub>	External Voltage Monitor 2. V <sub>IN2</sub> is typically used to monitor voltage supplies of +3.3V for MAX6655 and +5.0V for MAX6656.
12	ALERT	SMBus Alert (Interrupt) Output, Open-Drain
13	SMBDATA	SMBus Serial-Data Input/Output, Open-Drain
14	$\overline{\text{OVERT}}$	Overtemperature Alarm Output, Open-Drain. $\overline{\text{OVERT}}$ is an unlatched alarm output that responds to the programmed maximum temperature limit for all temperature channels.
15	SMBCLK	SMBus Serial-Clock Input
16	$\overline{\text{STBY}}$	Hardware Standby Input. Drive $\overline{\text{STBY}}$ low for low-power standby mode. Drive $\overline{\text{STBY}}$ high for normal operating mode. Temperature and comparison threshold data are retained in standby mode.

## Detailed Description

The MAX6655/MAX6656 are voltage and temperature monitors that communicate through an SMBus-compatible interface with a microprocessor or microcontroller in thermal management applications.

Essentially an 11-bit serial ADC with a sophisticated front end, the MAX6655/MAX6656 contain a switched-current source, a multiplexer, an ADC, an SMBus interface, and the associated control logic. Temperature data from the ADC is loaded into a data register, where it is automatically compared with data previously stored in over/under-temperature alarm threshold registers. Temperature data can be read at any time with 11 bits of resolution.

The MAX6655/MAX6656 can monitor external supply voltages of typically 12V, 2.5V, and 3.3V for the MAX6655 and 5.0V for the MAX6656, as well as their own supply voltage. All voltage inputs are converted to an 8-bit code using an ADC. Each input voltage is scaled down by an

on-chip resistive-divider so that its output, at the nominal input voltage, is approximately 3/4 of the ADC's full-scale range, or a decimal count of 198.

### ADC

The averaging ADC integrates over a 40ms period (typ) with excellent noise rejection. The ADC converts a temperature measurement in 125ms (typ) and a voltage measurement in 62.5ms (typ). For temperature measurements, the multiplexer automatically steers bias currents through the remote diode, then the forward voltage is measured and the temperature is computed. The DXN input is biased at one diode drop above ground by an internal diode to set up the ADC inputs for a differential measurement. The worst-case DXP-DXN differential input voltage range is +0.25V to +0.95V.

Excess resistance in series with the remote diode causes about +1/2°C error/Ω. A 200μV offset voltage at DXP-DXN causes about -1°C error.

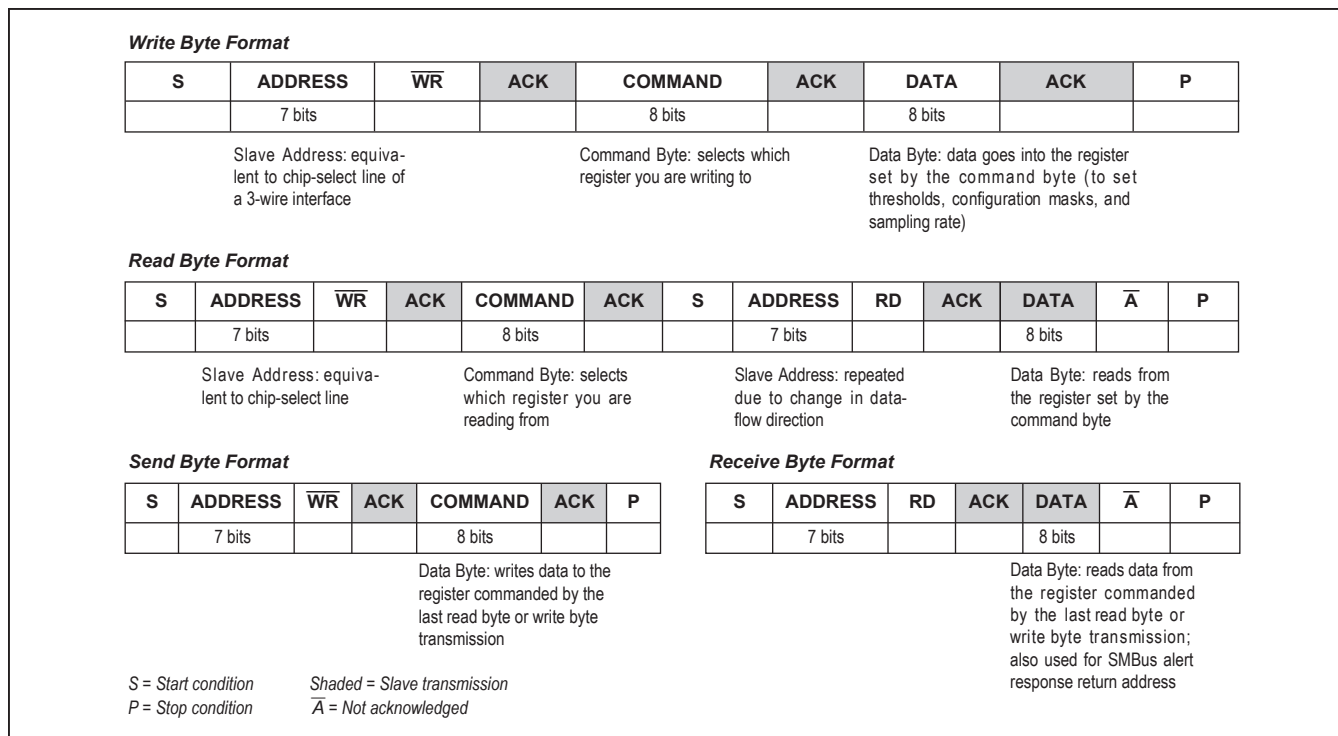

Figure 1. SMBus/I<sup>2</sup>C Protocols

### ADC Conversion Sequence

Each time a conversion begins, all channels are converted, and the results of the measurements are available after the end of conversion. A BUSY status bit in the Status Byte shows that the device is actually performing a new conversion; however, even if the ADC is busy, the results of the previous conversion are always available. The conversion sequence for the MAX6655 (MAX6656) is External Diode 1, External Diode 2, Internal Diode, V<sub>IN3</sub>, V<sub>IN2</sub> (V<sub>CC</sub>), V<sub>IN1</sub>, V<sub>CC</sub> (V<sub>IN2</sub>).

The ADC always converts at maximum speed, but the time between a sequence of conversions is adjustable. The Conversion Rate Control Byte (Table 1) shows the possible delays between conversions. Disabling voltage or temperature measurements with the Configuration Byte makes the ADC complete the conversion sequence faster.

### Low-Power Standby Mode

Standby mode disables the ADC and reduces the supply current drain to 3µA (typ). Enter standby mode by forcing  $\overline{STBY}$  low or through the RUN/STOP bit in

the Configuration Byte register. Hardware and software standby modes behave identically; all data is retained in memory, and the SMBus interface is alive and listening for reads and writes. Standby mode is not a shutdown mode. Activity on the SMBus draws extra supply current (see *Typical Operating Characteristics*).

Enter hardware standby mode by forcing  $\overline{STBY}$  low. In a notebook computer, this line may be connected to the system SUSTAT# suspend-state signal. The  $\overline{STBY}$  low state overrides any software conversion command. If a hardware or software standby command is received while a conversion is in progress, the conversion cycle is truncated, and the data from that conversion is not latched into the Temperature Reading register. The previous data is not changed and remains available.

Supply current during the 125ms conversion is typically 550µA. Between conversions, the instantaneous supply current is about 25µA, due to the current consumed by the conversion-rate timer. With very low supply voltages (under the POR threshold), the supply current is higher due to the address input bias currents.

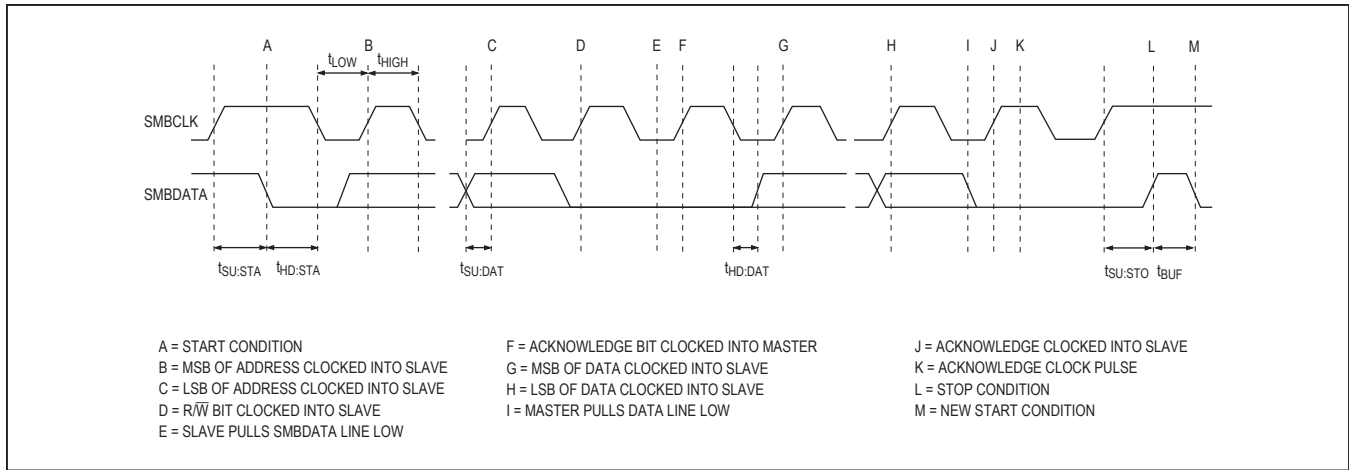

Figure 2. SMBus/I<sup>2</sup>C Write Timing Diagram

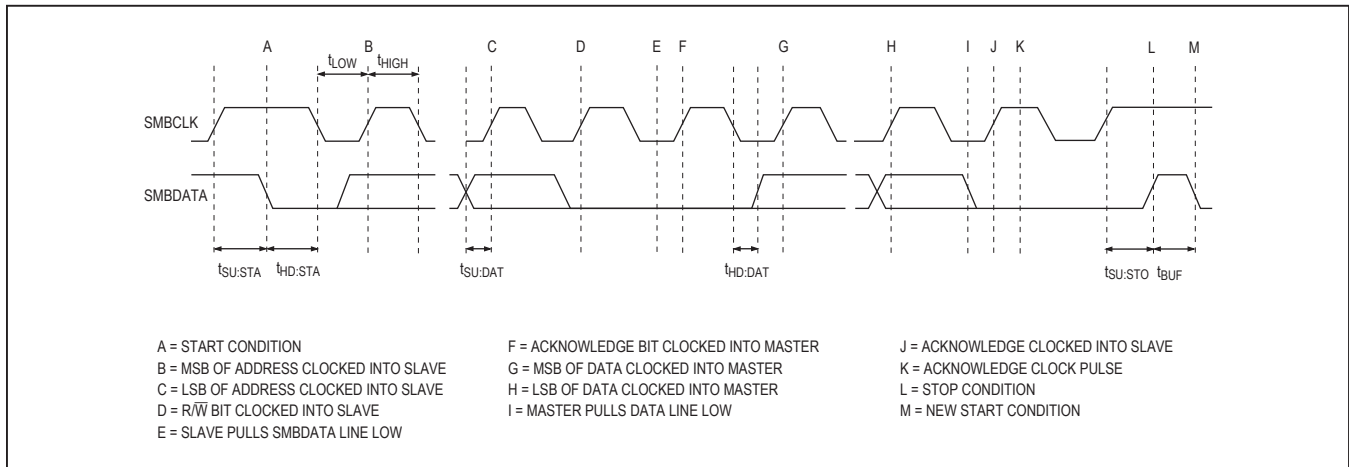

Figure 3. SMBus/I<sup>2</sup>C Read Timing Diagram

### SMBus Digital Interface

From a software perspective, the MAX6655/MAX6656 appear as a set of byte-wide registers that contain temperature data, voltage data, alarm threshold values, and control bits. Use a standard SMBus 2-wire serial interface to read temperature data and write control bits and alarm threshold data.

The MAX6655/MAX6656 employ four standard SMBus protocols: Write Byte, Read Byte, Send Byte, and Receive Byte (Figures 1, 2, and 3). The two shorter protocols (Receive and Send) allow quicker transfers, provided that the correct data register was previously selected by a Write or Read Byte instruction. Use caution with the shorter protocols in multimaster systems, since a second master could overwrite the Command Byte without informing the first master.



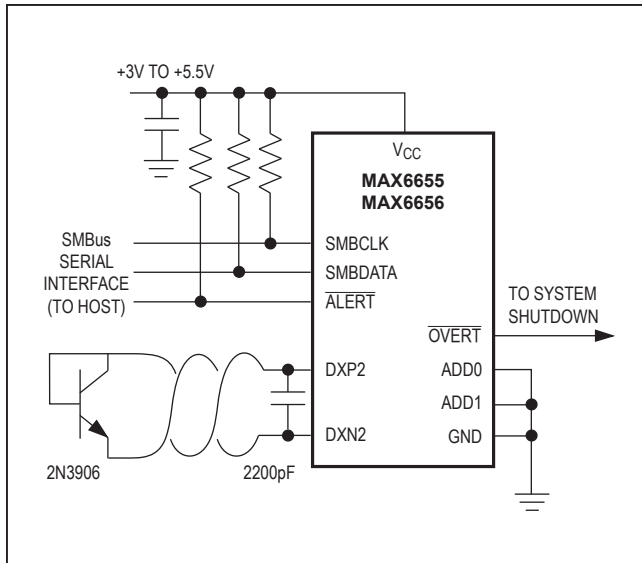

Figure 4. System Shutdown Application

The temperature data is stored in internal registers RRTE, RRT2, and RLTS as 7 bits + sign in two’s complement form with each LSB representing 1°C. Additionally, the 3MSBs of the Extended Temperature register contain fractional temperature data with +0.125°C resolution (Tables 2 and 3). The voltage data is stored in RV0, RV1, RV2, and RV3 as 8 bits in binary form (Table 4).

**OVERT Output**

$\overline{\text{OVERT}}$  output is an unlatched open-drain output that behaves as a thermostat for fan control or system shutdown (Figure 4). This output responds to the current temperature. If the current temperature is above  $T_{\text{HIGH}}$ , OVERT activates and does not go inactive until the temperature drops below  $T_{\text{HIGH}}$ .

**Diode Fault Alarm**

A continuity fault detector at DXP detects whether the remote diode has an open-circuit condition, short-circuit to GND, or short-circuit DXP-to-DXN condition. At the beginning of each conversion, the diode fault is checked, and the Status Byte is updated. This fault detector is a simple voltage detector; if DXP rises above  $V_{\text{CC}} - 1\text{V}$  (typ) or below  $V_{\text{DXN}} + 50\text{mV}$  (typ), a fault is detected. Note that the diode fault isn’t checked until a conversion is initiated, so immediately after POR, the status byte indicates no fault is present, even if the diode path is broken.

If the remote channel is shorted (DXP to DXN or DXP to GND), the ADC reads 1111 1111 so as not to trip either the  $T_{\text{HIGH}}$  or  $T_{\text{LOW}}$  alarms at their POR settings. Similarly,

if DXP\_ is short circuited to  $V_{\text{CC}}$ , the ADC reads -1°C for both remote channels, and the  $\overline{\text{ALERT}}$  outputs are activated.

**Alert Interrupts**

Normally, the  $\overline{\text{ALERT}}$  interrupt output signal is latched and can be cleared either by responding to the Alert Response Address or by reading the Status register. Interrupts are generated in response to  $T_{\text{HIGH}}$  and  $T_{\text{LOW}}$ ,  $V_{\text{HIGH}}$  and  $V_{\text{LOW}}$  comparisons, and when the remote diode is faulted. The interrupt does not halt automatic conversions; new temperature data continues to be available over the SMBus interface after  $\overline{\text{ALERT}}$  is asserted. The interrupt output pin is open-drain so multiple devices can share a common interrupt line.

The interface responds to the SMBus Alert Response address, an interrupt pointer return-address feature (see the *Alert Response Address* section). Before taking corrective action, always check to ensure that an interrupt is valid by reading the current temperature. The alert activates only once per crossing of a given temperature threshold to prevent any reentrant interrupts. To enable a new interrupt, rewrite the value of the violated temperature threshold.

**Alert Response Address**

The SMBus Alert Response interrupt pointer provides quick fault identification for simple slave devices that lack the complex, expensive logic needed to be a bus master. Upon receiving an  $\overline{\text{ALERT}}$  interrupt signal, the host master can broadcast a Receive Byte transmission to the Alert Response slave address (0001100). Any slave device that generated an interrupt then attempts to identify itself by putting its own address on the bus (Table 5).

The Alert Response can activate several different slave devices simultaneously, similar to the I<sup>2</sup>C General Call. If more than one slave attempts to respond, bus arbitration rules apply, and the device with the lower address code wins. The losing device does not generate an acknowledgment and continues to hold the  $\overline{\text{ALERT}}$  line low until serviced (implies that the host interrupt input is level sensitive). The alert is cleared after the slave address is returned to the host.

**Command Byte Functions**

The 8-bit Command Byte register (Table 6) is the master index that points to the other registers within the MAX6655/MAX6656. The register’s POR state is 0000 0000, so a Receive Byte transmission (a protocol that lacks the Command Byte) that occurs immediately after POR returns the current internal temperature data.



### Alarm Threshold Registers

Seventeen registers store  $\overline{\text{ALARM}}$  and  $\overline{\text{OVERT}}$  threshold data. The MAX6655/MAX6656 contain three registers for high-temperature ( $T_{\text{HIGH}}$ ), three for low-temperature ( $T_{\text{LOW}}$ ), four for high-voltage ( $V_{\text{HIGH}}$ ), four for low-voltage ( $V_{\text{LOW}}$ ) thresholds, and three more registers store  $\overline{\text{OVERT}}$  data. If a measured temperature or voltage exceeds the corresponding alarm threshold value, an  $\overline{\text{ALARM}}$  interrupt is asserted.  $\overline{\text{OVERT}}$  asserts when temperature exceeds the corresponding alarm threshold value. The POR state of the  $T_{\text{HIGH}}$  register is full scale (0111 1111 or +127°C). The POR state of the  $T_{\text{LOW}}$  register is 1100 1001 or -55°C.

### Configuration Byte Functions

Configuration Bytes 1 and 2 (Tables 7 and 8) are used to mask (disable) interrupts, disable temperature and voltage measurements, and put the device in software standby mode. The serial interface can read back the contents of these registers.

### Status Byte Functions

The two Status Byte registers (Tables 9 and 10) indicate which (if any) temperature or voltage thresholds have been exceeded. Status Byte 1 also indicates whether the ADC is converting and whether there is a fault in the remote-diode DXP-DXN path. After POR, the normal state of all the flag bits is zero, except the MSB, assuming none of the alarm conditions are present. The MSB toggles between 1 and 0 indicating whether the ADC is converting or not. A Status Byte is cleared by any successful read of that Status Byte. Note that the  $\overline{\text{ALERT}}$  interrupt latch clears when the status flag bit is read, but immediately asserts after the next conversion if the fault condition persists.

High and low alarm conditions can exist at the same time in the Status Byte because the MAX6655/MAX6656 are correctly reporting environmental changes.

## Applications Information

### Remote-Diode Selection

Remote temperature accuracy depends on having a good-quality, diode-connected transistor. See Table 11 for appropriate discrete transistors. The MAX6655/MAX6656 can directly measure the die temperature of CPUs and other ICs with on-board temperature-sensing transistors.

The transistor must be a small-signal type with a relatively high forward voltage. This ensures that the input voltage is within the ADC input voltage range. The forward voltage must be greater than 0.25V at 10 $\mu$ A at the highest expect-

ed temperature. The forward voltage must be less than 0.95V at 100 $\mu$ A at the lowest expected temperature. The base resistance has to be less than 100 $\Omega$ . Tight specification of forward-current gain (+50 to +150, for example) indicates that the manufacturer has good process controls and that the devices have consistent  $V_{\text{BE}}$  characteristics. Do not use power transistors.

### Self-Heating

Thermal mass can significantly affect the time required for a temperature sensor to respond to a sudden change in temperature. The thermal time constant of the 16-pin QSOP package is about 140s in still air. When measuring local temperature, it senses the temperature of the PC board to which it is soldered. The leads provide a good thermal path between the PC board traces and the MAX6655/MAX6656 die. Thermal conductivity between the MAX6655/MAX6656 die and the ambient air is poor by comparison. Because the thermal mass of the PC board is far greater than that of the MAX6655/MAX6656, the device follows temperature changes on the PC board with little or no perceivable delay.

When measuring temperature with discrete remote sensors, the use of smaller packages, such as a SOT23, yields the best thermal response time. Take care to account for thermal gradients between the heat source and the sensor, and ensure that stray air currents across the sensor package do not interfere with measurement accuracy. When measuring the temperature of a CPU or other IC with an on-chip sense junction, thermal mass has virtually no effect; the measured temperature of the junction tracks the actual temperature within a conversion cycle.

Self-heating does not significantly affect measurement accuracy. Remote-sensor self-heating due to the diode current source is negligible. For the local diode, the worst-case error occurs when autoconverting at the fastest rate and simultaneously sinking maximum current at the ALERT output. For example, at the minimum delay between conversions, and with ALERT sinking 1mA, the typical power dissipation is  $V_{\text{CC}} \times 550\mu\text{A} + 0.4\text{V} \times 1\text{mA}$ . Package  $\theta_{\text{JA}}$  is about 150°C/W, so with  $V_{\text{CC}} = +5\text{V}$  and no copper PC board heat sinking, the resulting temperature rise is:

$$\Delta T = 3.1\text{mW} \times 150^\circ\text{C/W} = +0.46^\circ\text{C}$$

Even with these contrived circumstances, it is difficult to introduce significant self-heating errors.

### ADC Noise Filtering

The integrating ADC has inherently good noise rejection, especially of low-frequency signals such as 60Hz/120Hz power-supply hum. Micropower operation places con-

straints on high-frequency noise rejection. Lay out the PC board carefully with proper external noise filtering for high-accuracy remote measurements in electrically noisy environments. Filter high-frequency electromagnetic interference (EMI) at DXP and DXN with an external 2200pF capacitor connected between the two inputs. This capacitor can be increased to about 3300pF (max), including cable capacitance. A capacitance higher than 3300pF introduces errors due to the rise time of the switched-current source.

If necessary, bypass  $V_{IN}$  pins with any appropriate-value capacitor for greater noise performance. Do not put resistance in series with the inputs. Series resistance degrades voltage measurements.

**PC Board Layout**

- 1) Place the MAX6655/MAX6656 as close as practical to the remote diode. In a noisy environment, such as a computer motherboard, this distance can be 4in to 8in (typ) or more, as long as the worst noise sources (such as CRTs, clock generators, memory buses, and ISA/PCI buses) are avoided.
- 2) Do not route the DXP-DXN lines next to the deflection coils of a CRT. Also, do not route the traces across a fast memory bus, which can easily introduce +30°C error, even with good filtering. Otherwise, most noise sources are fairly benign.
- 3) Route the DXP and DXN traces parallel and close to each other, away from any high-voltage traces such as +12VDC. Avoid leakage currents from PC board contamination. A 20mΩ leakage path from DXP to ground causes approximately +1°C error.
- 4) Connect guard traces to GND on either side of the DXP-DXN traces when possible (Figure 5). With guard traces in place, routing near high-voltage traces is no longer an issue.
- 5) Route as few vias and crossunders as possible to minimize copper/solder thermocouple effects.
- 6) When introducing a thermocouple, make sure that both the DXP and the DXN paths have matching thermocouples. In general, PC board-induced thermocouples are not a serious problem. A copper-solder thermocouple exhibits 3μV/°C, and it takes approximately 200μV of voltage error at DXP-DXN to cause a 1°C measurement error, so most parasitic thermocouple errors are swamped out.
- 7) Use wide traces. Narrow traces are more inductive and tend to pick up radiated noise. The 10-mil widths and spacings recommended in Figure 5 are not absolutely necessary (as they offer only a minor improvement in leakage and noise), but use

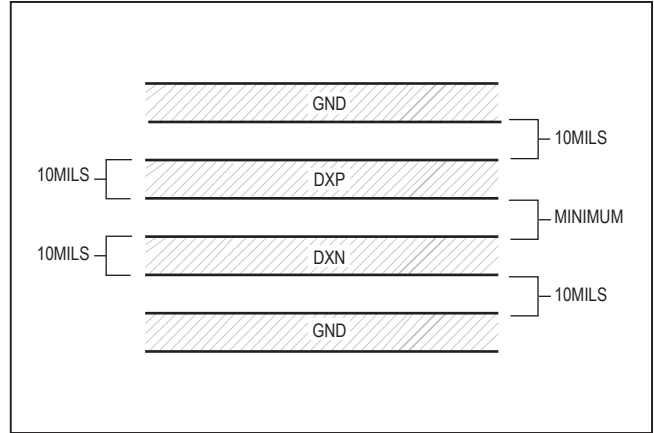

Figure 5. Recommended DXP/DXN PC Traces

them where practical.

- 8) Note that copper cannot be used as an EMI shield. Placing a copper ground plane between the DXPDXN traces and traces carrying high-frequency noise signals does not help reduce EMI.

**Twisted Pair and Shielded Cables**

For remote-sensor distances longer than 8in, or in particularly noisy environments, a twisted pair is recommended. Its practical length is 6ft to 12ft (typ) before noise becomes a problem, as tested in a noisy electronics laboratory. For longer distances, the best solution is a shielded twisted pair like that used for audio microphones. For example, Belden #8451 works well for distances up to 100ft in a noisy environment. Connect the twisted pair to DXP and DXN and the shield to GND, and leave the shield's remote end unterminated. Excess capacitance at DX\_ limits practical remote-sensor distances (see *Typical Operating Characteristics*).

For very long cable runs, the cable's parasitic capacitance often provides noise filtering, so the recommended 2200pF capacitor can often be removed or reduced in value.

Cable resistance also affects remote-sensor accuracy. A 1Ω series resistance introduces about +1/2°C error.

**Chip Information**

TRANSISTOR COUNT: 26,783

PROCESS: BiCMOS

**Table 1. Conversion Rate Control Byte**

DATA (RCRA, 04H)	WAIT TIME BETWEEN CONVERSION SEQUENCES (s)
00h	0
01h	0.125
02h	0.250
03h	0.500
04h	1.000
05h	2.000
06h	4.000
07h	4.000

**Table 3. Extended Resolution Register**

FRACTIONAL TEMPERATURE (°C)	DIGITAL OUTPUT
0	0000 0000
0.125	0010 0000
0.250	0100 0000
0.375	0110 0000
0.500	1000 0000
0.625	1010 0000
0.750	1100 0000
0.875	1110 0000

**Table 2. Temperature Data Format**

TEMP (°C)	ROUNDED TEMP (°C)	DIGITAL OUTPUT
130.00	+127	0 111 1111
127.00	+127	0 111 1111
126.00	+126	0 111 1111
25.25	+25	0 001 1001
0.50	+1	0 000 0001
0	0	0 000 0000
-0.625	-1	1 111 1111
-65	-65	1 011 1111
Diode Fault (Short or Open)	—	1111 1111

**Table 4. Voltage Data Format**

ADC OUTPUT CODE	INPUT VOLTAGE AT $V_{IN1}$ (+12V)	INPUT VOLTAGE AT $V_{IN2}$ (+5V) OR $V_{CC}$	INPUT VOLTAGE AT $V_{IN2}$ (+3.3V) OR $V_{CC}$	INPUT VOLTAGE AT $V_{IN3}$ (+2.5V)
LSB weight	57.1mV	23.8mV	15.7mV	11.9mV
64 ( $\approx$ 1/4 scale)	4.343V to 4.400V	1.810V to 1.833V	1.194V to 1.210V	0.905V to 0.917V
65	4.400V to 4.457V	1.833V to 1.857V	1.210V to 1.226V	0.917V to 0.929V
66	4.457V to 4.514V	1.857V to 1.881V	1.226V to 1.242V	0.929V to 0.941V
—	—	—	—	—
128 ( $\approx$ 1/2 scale)	8.000V to 8.057V	3.333V to 3.357V	2.200V to 2.216V	1.667V to 1.679V
—	—	—	—	—
198 ( $\approx$ 3/4 scale)	12.000V to 12.057V	5.000V to 5.024V	3.300V to 3.3157V	2.500V to 2.512V
—	—	—	—	—
210	12.686V to 12.743V	5.286V to 5.310V	3.486V to 3.504V	2.643V to 2.655V
211	12.743V to 12.800V	5.310V to 5.333V	3.504V to 3.521V	2.655V to 2.667V
—	—	—	—	—
237 ( $\approx$ 5/4 scale)	14.228V to 14.285V	5.929V to 5.952V	3.913V to 3.929V	2.964V to 2.976V

**Note:** Actual voltage =  $V_{IN} \times (\text{ADC output code} + 12)/210$ ,  $V_{IN} = 2.5/3.3/5/12V$

**Table 5. Address Map (ADD[1:0])**

ADD0	ADD1	ADDRESS
0	0	0011 0000
0	High-Z	0011 0010
0	1	0011 0100
High-Z	0	0101 0010
High-Z	High-Z	0101 0100
High-Z	1	0101 0110
1	0	1001 1000
1	High-Z	1001 1010
1	1	1001 1100

Table 6. Command Byte Register Map

REGISTER	ADDRESS	POR STATE	FUNCTION
RLTS	00h	0000 0000	Read Internal Temperature
RRTE	01h	0000 0000	Read External Temperature 1
RSL	02h	0000 0000	Read Status Byte; Note 1
RCL	03h	0000 0000	Read Configuration Byte
RCRA	04h	0000 0010	Read Conversion Rate Byte
RLHN	05h	0111 1111	Read Internal $\overline{\text{ALERT}}$ High Limit
RLLI	06h	1100 1001	Read Internal $\overline{\text{ALERT}}$ Low Limit
RRHI	07h	0111 1111	Read External Temperature 1 $\overline{\text{ALERT}}$ High Limit
RRLS	08h	1100 1001	Read External Temperature 1 $\overline{\text{ALERT}}$ Low Limit
WCA	09h	N/A	Write Configuration Byte
WCRW	0Ah	N/A	Write Conversion Rate Control Byte
WLHO	0Bh	N/A	Write Internal $\overline{\text{ALERT}}$ High Limit
WLLM	0Ch	N/A	Write Internal $\overline{\text{ALERT}}$ Low Limit
WRHA	0Dh	N/A	Write External Temperature 1 $\overline{\text{ALERT}}$ High Limit
WRLN	0Eh	N/A	Write External Temperature 1 $\overline{\text{ALERT}}$ Low Limit
RRET1	10h	0000 0000	Read External 1 Extended Temperature
RRET2	11h	0000 0000	Read External 2 Extended Temperature
RLET	12h	0000 0000	Read Internal Extended Temperature
RRT2	13h	0000 0000	Read External Temperature 2
RRHL2	14h	0111 1111	Read External Temperature 2 $\overline{\text{ALERT}}$ High Limit
RRL2	15h	1100 1001	Read External Temperature 2 $\overline{\text{ALERT}}$ Low Limit
RLOL	16h	0111 1111	Read Internal OVERT Limit
RLOL1	17h	0111 1111	Read External 1 OVERT Limit
RLOL2	18h	0111 1111	Read External 2 OVERT Limit
WLOL	19h	N/A	Write Internal OVERT Limit
WROL1	1Ah	N/A	Write External 1 OVERT Limit
WROL2	1Bh	N/A	Write External 2 OVERT Limit
WRH2	1Ch	N/A	Write External Temperature 2 $\overline{\text{ALERT}}$ High Limit
WRL2	1Dh	N/A	Write External Temperature 2 $\overline{\text{ALERT}}$ Low Limit
WV0HL	1Eh	N/A	Write $V_{CC}$ ( $V_{IN2}$ ) $\overline{\text{ALERT}}$ High Limit for MAX6655 (MAX6656)
WV0LL	1Fh	N/A	Write $V_{CC}$ ( $V_{IN2}$ ) $\overline{\text{ALERT}}$ Low Limit for MAX6655 (MAX6656)
WV1HL	20h	N/A	Write $V_{IN1}$ $\overline{\text{ALERT}}$ High Limit
WV1LL	21h	N/A	Write $V_{IN1}$ $\overline{\text{ALERT}}$ Low Limit
WV2HL	22h	N/A	Write $V_{IN2}$ ( $V_{CC}$ ) $\overline{\text{ALERT}}$ High Limit for MAX6655 (MAX6656)
WV2LL	23h	N/A	Write $V_{IN2}$ ( $V_{CC}$ ) $\overline{\text{ALERT}}$ Low Limit for MAX6655 (MAX6656)
WV3HL	24h	N/A	Write $V_{IN3}$ $\overline{\text{ALERT}}$ High Limit
WV3LL	25h	N/A	Write $V_{IN3}$ $\overline{\text{ALERT}}$ Low Limit
RV0HL	26h	1101 0011	Read $V_{CC}$ ( $V_{IN2}$ ) $\overline{\text{ALERT}}$ High Limit for MAX6655 (MAX6656)
RV0LL	27h	1010 1101	Read $V_{CC}$ ( $V_{IN2}$ ) $\overline{\text{ALERT}}$ Low Limit for MAX6655 (MAX6656)

Table 6. Command Byte Register Map (continued)

REGISTER	ADDRESS	POR STATE	FUNCTION
RV1HL	28h	1101 0011	Read $V_{IN1}$ $\overline{\text{ALERT}}$ High Limit
RV1LL	29h	1010 1101	Read $V_{IN1}$ $\overline{\text{ALERT}}$ Low Limit
RV2HL	2Ah	1101 0011	Read $V_{IN2}$ ( $V_{CC}$ ) $\overline{\text{ALERT}}$ High Limit for MAX6655 (MAX6656)
RV2LL	2Bh	1010 1101	Read $V_{IN2}$ ( $V_{CC}$ ) $\overline{\text{ALERT}}$ Low Limit for MAX6655 (MAX6656)
RV3HL	2Ch	1101 0011	Read $V_{IN3}$ $\overline{\text{ALERT}}$ High Limit
RV3LL	2Dh	1010 1101	Read $V_{IN3}$ $\overline{\text{ALERT}}$ Low Limit
RV0	2Eh	0000 0000	Read $V_{CC}$ ( $V_{IN2}$ ) for MAX6655 (MAX6656)
RV1	2Fh	0000 0000	Read $V_{IN1}$
RV2	30h	0000 0000	Read $V_{IN2}$ ( $V_{CC}$ ) for MAX6655 (MAX6656)
RV3	31h	0000 0000	Read $V_{IN3}$
RSL2	32h	0000 0000	Read Status Byte 2
RCL2	33h	0000 0000	Read Configuration Byte 2
WCA2	34h	N/A	Write Configuration Byte 2
RDID	FEh	0000 1010	Read Device ID
RDRV	FFh	0100 1101	Read Manufacture ID

**Note 1:** Upon application of power, the ADC begins converting. The MSB of the Status Byte register indicates a conversion in progress. The Status Byte has a value of 80h during conversions and a value of 00h between conversions. Therefore, at power-on, the Status Byte alternates between 00h and 80h.

Table 7. Configuration Byte 1 Bit Assignments

BIT	NAME	POR STATE	FUNCTION
7 (MSB)	Mask All	0	Masks out all $\overline{\text{ALERT}}$ interrupts if high.
6	RUN/STOP	0	Standby mode control bit; if high, the device immediately stops converting and enters standby mode. If low, the device enters normal conversion mode.
5	Mask Remote Temperature 1	0	High masks out $\overline{\text{OVERT}}$ and $\overline{\text{ALERT}}$ interrupts due to remote-diode 1.
4	Mask Remote Temperature 2	0	High masks out $\overline{\text{OVERT}}$ and $\overline{\text{ALERT}}$ interrupts due to remote-diode 2.
3	Mask $V_{IN3}$	0	High masks $\overline{\text{ALERT}}$ interrupts due to $V_{IN3}$ .
2	Mask $V_{IN2}$	0	High masks $\overline{\text{ALERT}}$ interrupts due to $V_{IN2}$ ( $V_{CC}$ ) for MAX6655 (MAX6656).
1	Mask $V_{IN1}$	0	High masks $\overline{\text{ALERT}}$ interrupts due to $V_{IN1}$ .
0	Mask $V_{CC}$	0	High masks $\overline{\text{ALERT}}$ interrupts due to $V_{CC}$ ( $V_{IN2}$ ) for MAX6655 (MAX6656).



Table 8. Configuration Byte 2-Bit Assignments

BIT	NAME	POR STATE	FUNCTION
7 (MSB)	Disable Remote Temperature 1 Measurement	0	If high, the remote temperature 1 measurement is disabled.
6	Disable Remote Temperature 2 Measurement	0	If high, the remote temperature 2 measurement is disabled.
5	Disable Internal Temperature Measurement	0	If high, the internal temperature measurement is disabled.
4	Disable $V_{IN3}$ Measurement	0	If high, the input voltage $V_{IN3}$ measurement is disabled.
3	Disable $V_{IN2}$ Measurement	0	If high, the input voltage $V_{IN2}$ ( $V_{CC}$ ) measurement is disabled for MAX6655 (MAX6656).
2	Disable $V_{IN1}$ Measurement	0	If high, the input voltage $V_{IN1}$ measurement is disabled.
1	Disable $V_{CC}$ Measurement	0	If high, the input voltage $V_{CC}$ ( $V_{IN2}$ ) measurement is disabled for MAX6655 (MAX6656).
0	Reserved	0	Reserved for future use.

Table 9. Status Byte 1-Bit Assignments

BIT	NAME	POR STATE	FUNCTION
7 (MSB)	BUSY	0	ADC is busy converting when high.
6	LHIGH	0	Internal high-temperature $\overline{\text{ALERT}}$ has tripped when high; cleared by POR or readout of the entire Status Byte.
5	LLOW	0	Internal low-temperature $\overline{\text{ALERT}}$ has tripped when high; cleared by POR or readout of the entire Status Byte.
4	RHIGH	0	External 1 high-temperature $\overline{\text{ALERT}}$ has tripped when high; cleared by POR or readout of the entire Status Byte.
3	RLOW	0	External 1 low-temperature $\overline{\text{ALERT}}$ has tripped when high; cleared by POR or readout of the entire Status Byte.
2	DODS1	0	A high indicates external diode 1 open/short.
1	R2HIGH	0	External 2 high-temperature $\overline{\text{ALERT}}$ has tripped when high; cleared by POR or readout of the entire Status Byte.
0	R2LOW	0	External 2 low-temperature $\overline{\text{ALERT}}$ has tripped when high; cleared by POR or readout of the entire Status Byte.

Table 10. Status Byte 2-Bit Assignments

BIT	NAME	POR STATE	FUNCTION
7(MSB)	LO	0	Internal temperature has exceeded $\overline{\text{OVERT}}$ limit. Clear by falling below limit.
6	R1O	0	External temperature 1 has exceeded $\overline{\text{OVERT}}$ limit. Clear by falling below limit.
5	R2O	0	External temperature 2 has exceeded $\overline{\text{OVERT}}$ limit. Clear by falling below limit.
4	DODS2	0	A high indicates external diode 2 open or short.
3	V <sub>A3</sub>	0	V <sub>IN3</sub> out of window $\overline{\text{ALERT}}$ has tripped when high; cleared by POR or reading the Status Byte.
2	V <sub>A2</sub>	0	V <sub>IN2</sub> out of window $\overline{\text{ALERT}}$ has tripped when high; cleared by POR or reading the Status Byte.
1	V <sub>A1</sub>	0	V <sub>IN1</sub> out of window $\overline{\text{ALERT}}$ has tripped when high; cleared by POR or reading the Status Byte.
0	V <sub>CCA</sub>	0	V <sub>CC</sub> out of window $\overline{\text{ALERT}}$ has tripped when high; cleared by POR or reading the Status Byte.

Table 11. Remote-Sensor Transistor  
Manufacturers

MANUFACTURER	MODEL NUMBER
Central Semiconductor (USA)	CMPT3906
Fairchild Semiconductor (USA)	MMBT3906
Infineon (Germany)	SMBT3906
ON Semiconductor (USA)	MMBT3906
Rohm Semiconductor (Japan)	SST3906
Zetex (England)	FMMT3906CT-ND

**Typical Application Circuit**

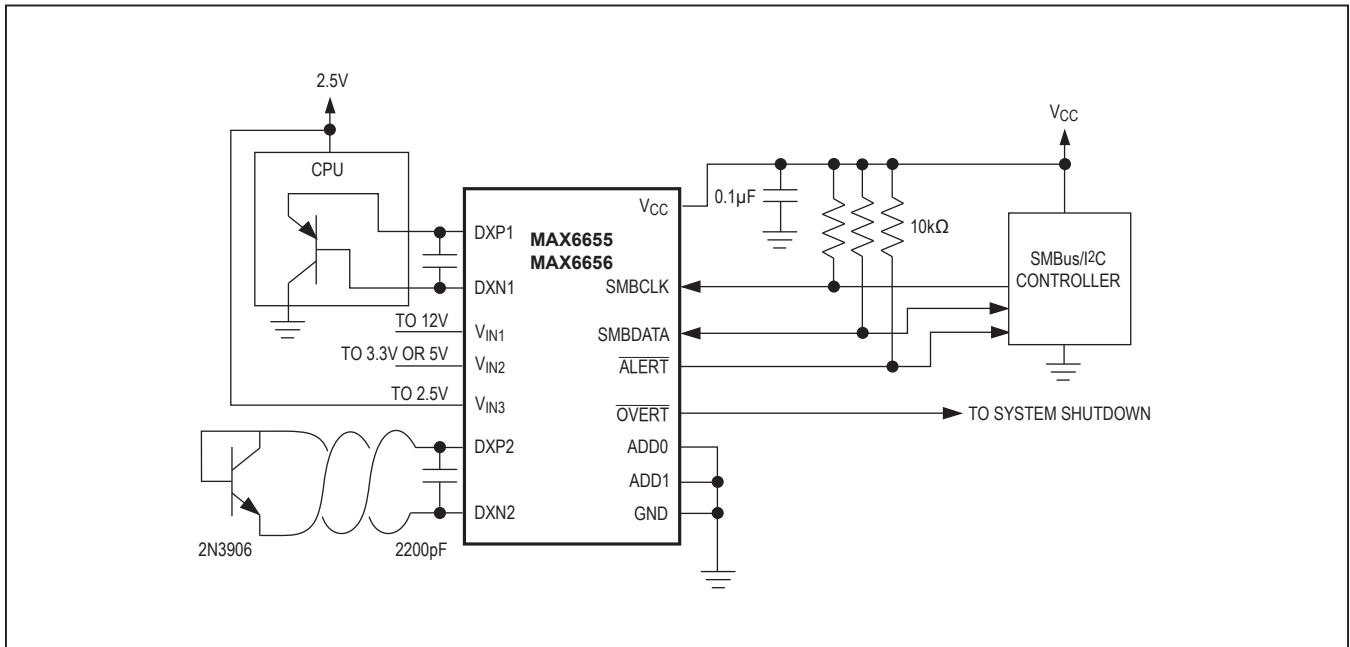

**Functional Diagram**

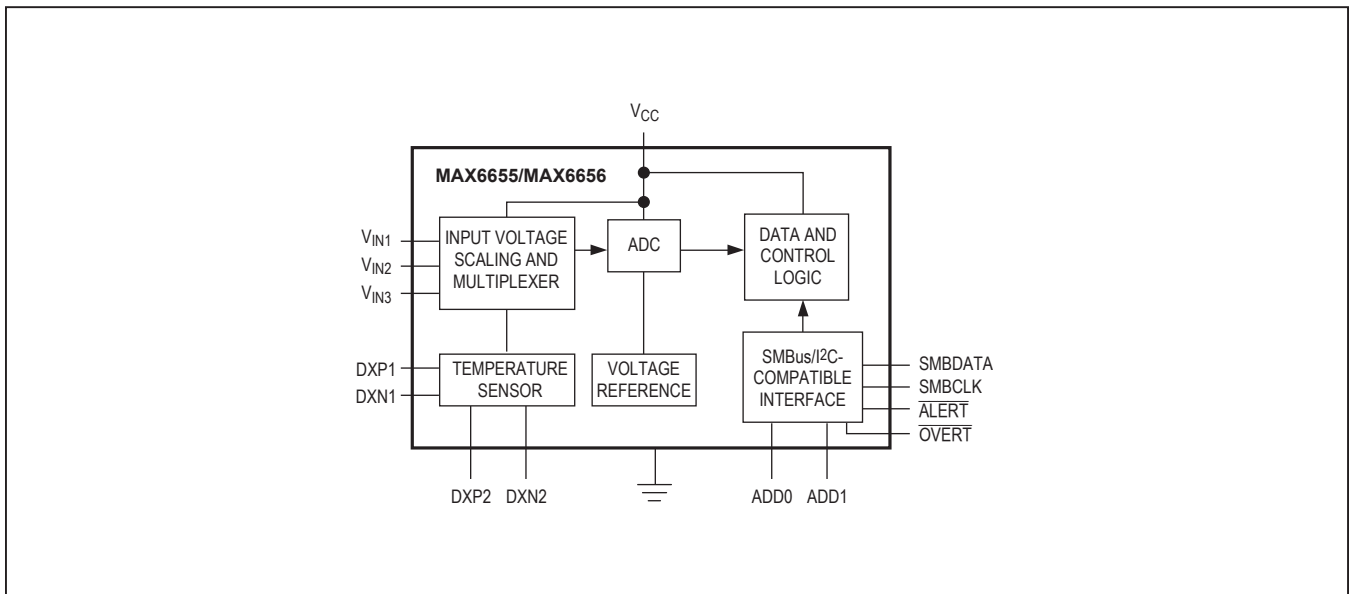

Package Information

For the latest package outline information and land patterns (footprints), go to [www.maximintegrated.com/packages](http://www.maximintegrated.com/packages). Note that a "+", "#", or "-" in the package code indicates RoHS status only. Package drawings may show a different suffix character, but the drawing pertains to the package regardless of RoHS status.

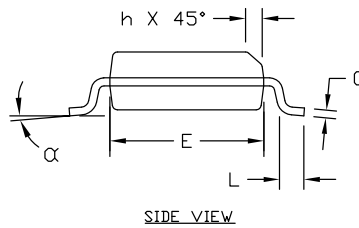
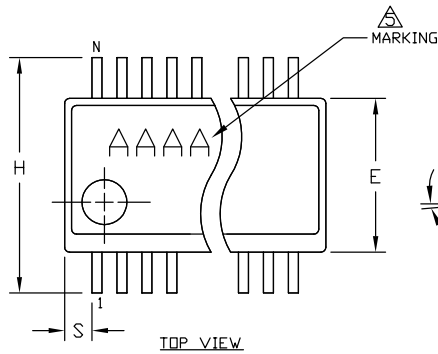

DIM	INCHES			MILLIMETERS		
	MIN	NOM	MAX	MIN	NOM	MAX
A	.053	.063	.069	1.35	1.60	1.75
A1	.004	.007	.010	0.102	0.169	0.254
A2	.049	.058	.065	1.245	1.473	1.651
B	.008	.010	.012	0.20	0.25	0.30
C	.0075	.0087	.0098	0.191	0.222	0.249
D	SEE VARIATIONS					
E	.150	.153	.157	3.81	3.89	3.99
e	.025 BSC			0.635 BSC		
H	.230	.236	.244	5.84	6.00	6.20
h	.010	---	.016	0.25	---	0.41 REF.
L	.016	.025	.035	0.41	0.64	0.89
N	SEE VARIATIONS					
alpha	0°	---	8°	0°	---	8°

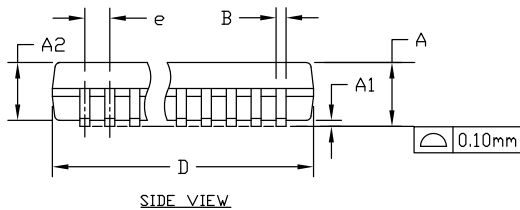

VARIATIONS:

	INCHES			MILLIMETERS			N	PKG. CODES
	MIN.	NOM	MAX.	MIN.	NOM	MAX.		
D	.189	.193	.196	4.80	4.90	4.98	16	E16-1, E16M-1, E16-4, E16-5, E16-5C, E16-8F, E16-11, E16-11C, E16-12, E16-12C, E16MS-1F
S	.0020	.0033	.0070	0.05	0.08	0.18		
D	.337	.341	.344	8.56	8.66	8.74	20	E20-1, E20-2, E20-3
S	.0500	.0535	.0550	1.270	1.270	1.397		
D	.337	.340	.344	8.56	8.64	8.74	24	E24-1, E24-2, E24-3
S	.0250	.0280	.0300	0.635	0.711	0.762		
D	.386	.390	.393	9.80	9.91	9.98	28	E28-1, E28M-1, E28-2
S	.0250	.0274	.0300	0.635	0.696	0.762		

- NOTES:
1. D & E DO NOT INCLUDE MOLD FLASH OR PROTRUSIONS.
  2. MOLD FLASH OR PROTRUSIONS NOT TO EXCEED .006" PER SIDE.
  3. CONTROLLING DIMENSIONS: INCHES.
  4. MEETS JEDEC MO137.
  5. MARKING SHOWN IS FOR PKG. ORIENTATION ONLY.
  6. ALL DIMENSIONS APPLY TO BOTH LEADED (-) AND PbFREE (+) PKG. CODES.

-DRAWING NOT TO SCALE-

TITLE:  
PACKAGE OUTLINE  
QSDP .150", .025" LEAD PITCH

APPROVAL	DOCUMENT CONTROL NO. 21-0055	REV. P	1/1
----------	---------------------------------	-----------	-----

**Revision History**

REVISION NUMBER	REVISION DATE	DESCRIPTION	PAGES CHANGED
2	5/17	Updated <i>Ordering Informaiton</i> table	1
3	3/21	Updated Table 4	12



*Information furnished by Analog Devices is believed to be accurate and reliable. However, no responsibility is assumed by Analog Devices for its use, nor for any infringements of patents or other rights of third parties that may result from its use. Specifications subject to change without notice. No license is granted by implication or otherwise under any patent or patent rights of Analog Devices. Trademarks and registered trademarks are the property of their respective owners.*