

MAXIM

Dual/Triple-Voltage μP Supervisory Circuits

MAX6351–MAX6360

General Description

The MAX6351–MAX6360 microprocessor (μP) supervisors with multiple reset voltages significantly improve system reliability and accuracy compared to separate ICs or discrete components. If any input supply voltage drops below its associated preset threshold, all reset outputs are asserted. In addition, the outputs are valid as long as either input supply voltage remains greater than +1.0V.

All devices in this series have an active-low debounced manual reset input. In addition, the MAX6358/MAX6359/MAX6360 offer a watchdog-timer input with a 46.4s start-up timeout period and a 2.9s timeout period. The MAX6355/MAX6356/MAX6357 offer an additional voltage monitor input to monitor a third voltage.

The MAX6351 features two active-low, push-pull reset outputs, one is referenced to V_{CC1} and the other is referenced to V_{CC2}. The MAX6353/MAX6356/MAX6359 offer an active-low, push-pull reset output referenced to V_{CC1}. The MAX6354/MAX6357/MAX6360 offer an active-low, push-pull reset output referenced to V_{CC2}.

All these devices are offered with a wide variety of voltage threshold levels, as shown in the *Voltage Threshold Levels* table. They are available in 5- and 6-pin SOT23 packages and operate over the extended (-40°C to +85°C) temperature range.

Voltage Threshold Levels

PART NO. SUFFIX (_)	V _{CC1} NOMINAL VOLTAGE THRESHOLD (V)	V _{CC2} NOMINAL VOLTAGE THRESHOLD (V)
LT	4.63	3.08
LS	4.63	2.93
LR	4.63	2.63
MT	4.38	3.08
MS	4.38	2.93
MR	4.38	2.63
TZ	3.08	2.32
TY	3.08	2.19
TW	3.08	1.67
TV	3.08	1.58
SZ	2.93	2.32
SY	2.93	2.19
SW	2.93	1.67
SV	2.93	1.58
UW	2.78	1.67
UV	2.78	1.58
RW	2.63	1.67
RV	2.63	1.58

Note: Standard versions are shown in bold. Sample stock is generally held on the standard versions only. Contact factory for availability.

Features

- ◆ Precision Monitoring of Multiple +1.8V, +2.5V, +3.0V, +3.3V, and +5V Power-Supply Voltages
- ◆ Precision Factory-Set Power-Supply Reset Thresholds
- ◆ 20μA Supply Current
- ◆ 100ms min Power-On Reset Pulse Width
- ◆ Debounced TTL/CMOS-Compatible Manual-Reset Input
- ◆ Watchdog Timer
 - 46.4s Startup Timeout
 - 2.9s Normal Timeout
- ◆ Fully Guaranteed Over Temperature
- ◆ Guaranteed RESET Valid to V_{CC1} = 1V or V_{CC2} = 1V
- ◆ Power-Supply Transient Immunity
- ◆ No External Components for Dual-Voltage Systems
- ◆ Small 5- and 6-Pin SOT23 Packages
- ◆ Low Cost

Applications

Computers
Intelligent Instruments
Controllers
Multivoltage Systems
Portable/Battery-Powered
Equipment

Ordering Information

PART*	TEMP RANGE	PIN-PACKAGE
MAX6351_ _UT-T	-40°C to +85°C	6 SOT23-6
MAX6352_ _UK-T	-40°C to +85°C	5 SOT23-5
MAX6353_ _UK-T	-40°C to +85°C	5 SOT23-5
MAX6354_ _UK-T	-40°C to +85°C	5 SOT23-5
MAX6355_ _UT-T	-40°C to +85°C	6 SOT23-6
MAX6356_ _UT-T	-40°C to +85°C	6 SOT23-6
MAX6357_ _UT-T	-40°C to +85°C	6 SOT23-6
MAX6358_ _UT-T	-40°C to +85°C	6 SOT23-6
MAX6359_ _UT-T	-40°C to +85°C	6 SOT23-6
MAX6360_ _UT-T	-40°C to +85°C	6 SOT23-6

*The _ _ are placeholders for the threshold voltage levels of the devices. Substitute the part number suffix in the Voltage Threshold Levels table for the desired voltage level. All devices are available in tape-and-reel only. There is a 2500 piece minimum order increment for the SOT package.

Devices are available in both leaded and lead-free packaging. Specify lead-free by replacing "-T" with "+T" when ordering.

Pin Configurations appear at end of data sheet.
Selector Guide appears at end of data sheet.

Maxim Integrated Products 1

For pricing, delivery, and ordering information, please contact Maxim/Dallas Direct! at 1-888-629-4642, or visit Maxim's website at www.maxim-ic.com.

Dual/Triple-Voltage µP Supervisory Circuits

ABSOLUTE MAXIMUM RATINGS

V _{CC1} , V _{CC2} to GND	-0.3V to +6V
R _{ST} (MAX6352/MAX6355/MAX6358)	-0.3V to +6V
R _{ST} , MR, WDI, R _{ST1} , R _{STIN} (MAX6351/MAX6353/ MAX6356/MAX6359)	-0.3V to (V _{CC1} + 0.3V)
R _{ST} , R _{ST2} (MAX6351/MAX6354/ MAX6357/MAX6360)	-0.3V to (V _{CC2} + 0.3V)

Input/Output Current, All Pins	20mA
Continuous Power Dissipation (T _A = +70°C)	
5-Pin SOT23 (derate 7.1mW/°C above +70°C)	571mW
6-Pin SOT23 (derate 8.7mW/°C above +70°C)	695mW
Operating Temperature Range	-40°C to +85°C
Junction Temperature	+150°C
Storage Temperature Range	-65°C to +150°C

Stresses beyond those listed under "Absolute Maximum Ratings" may cause permanent damage to the device. These are stress ratings only, and functional operation of the device at these or any other conditions beyond those indicated in the operational sections of the specifications is not implied. Exposure to absolute maximum rating conditions for extended periods may affect device reliability.

ELECTRICAL CHARACTERISTICS

(V_{CC1} = V_{CC2} = +1.2V to +5.5V, T_A = -40°C to +85°C, unless otherwise noted. Typical values are at T_A = +25°C.) (Note 1)

PARAMETER	SYMBOL	CONDITIONS	MIN	TYP	MAX	UNITS	
Supply Voltage	V _{CC1} , V _{CC2}	T _A = 0°C to +70°C	1.0		5.5	V	
		T _A = -40°C to +85°C	1.2		5.5		
Supply Current	I _{CC1} + I _{CC2}	V _{CC1} = 5.5V, V _{CC2} = 3.6V, all I/O pins open		20	50	µA	
V _{CC1} Threshold (Note 3)	V _{TH1}	MAX63__L__	T _A = +25°C	4.54	4.63	4.72	V
			T _A = -40°C to +85°C	4.5		4.75	
		MAX63__M__	T _A = +25°C	4.3	4.38	4.46	
			T _A = -40°C to +85°C	4.25		4.50	
		MAX63__T__	T _A = +25°C	3.03	3.08	3.14	
			T _A = -40°C to +85°C	3.00		3.15	
		MAX63__S__	T _A = +25°C	2.88	2.93	2.98	
			T _A = -40°C to +85°C	2.85		3.00	
		MAX63__U__	T _A = +25°C	2.74	2.78	2.82	
			T _A = -40°C to +85°C	2.70		2.85	
		MAX63__R__	T _A = +25°C	2.58	2.63	2.68	
			T _A = -40°C to +85°C	2.55		2.70	
V _{CC2} Threshold (Note 3)	V _{TH2}	MAX63__T	T _A = +25°C	3.03	3.08	3.14	V
			T _A = -40°C to +85°C	3.00		3.15	
		MAX63__S	T _A = +25°C	2.88	2.93	2.98	
			T _A = -40°C to +85°C	2.85		3.00	
		MAX63__R	T _A = +25°C	2.58	2.63	2.68	
			T _A = -40°C to +85°C	2.55		2.70	
		MAX63__Z	T _A = +25°C	2.28	2.32	2.35	
			T _A = -40°C to +85°C	2.25		2.38	
		MAX63__Y	T _A = +25°C	2.16	2.19	2.22	
			T _A = -40°C to +85°C	2.13		2.25	
		MAX63__W	T _A = +25°C	1.64	1.67	1.70	
			T _A = -40°C to +85°C	1.62		1.71	
MAX63__V	T _A = +25°C	1.55	1.58	1.61			
	T _A = -40°C to +85°C	1.53		1.62			

Dual/Triple-Voltage μP Supervisory Circuits

MAX6351-MAX6360

ELECTRICAL CHARACTERISTICS (continued)

(V_{CC1} = V_{CC2} = +1.2V to +5.5V, T_A = -40°C to +85°C, unless otherwise noted. Typical values are at T_A = +25°C.) (Note 1)

PARAMETER	SYMBOL	CONDITIONS	MIN	TYP	MAX	UNITS
Reset Threshold Tempco	ΔV _{TH} /°C			20		ppm/°C
Reset Threshold Hysteresis				V _{TH} /500		V
V _{CC} to Reset Delay		100mV overdrive		20		μs
Reset Timeout Period	t _{RP}	V _{CC1} > V _{TH1} (MAX), V _{CC2} > V _{TH2} (MAX)	100	180	280	ms
$\overline{\text{RESET}}$ Output Voltage Low	V _{OL}	V _{CC1} or V _{CC2} ≥ 2.7V, I _{SINK} = 1.2mA			0.3	V
		V _{CC1} or V _{CC2} ≥ 4.5V, I _{SINK} = 3.2mA			0.4	
		V _{CC1} or V _{CC2} ≥ 1V, I _{SINK} = 50μA, T _A = 0°C to +70°C			0.3	
		V _{CC1} or V _{CC2} ≥ 1.2V, I _{SINK} = 50μA; T _A = -40°C to +85°C			0.3	
$\overline{\text{RESET}}$ Output Voltage High (MAX6351/MAX6353/MAX6354/ MAX6356/MAX6357/MAX6359/ MAX6360 only)	V _{OH}	(_W, _V versions only), V _{CC1} > V _{TH1} (MAX), V _{CC2} > V _{TH2} (MAX)	I _{SOURCE} = 350μA	0.8 × V _{CC}		V
		(_Y versions only), V _{CC1} > V _{TH1} (MAX), V _{CC2} > V _{TH2} (MAX)	I _{SOURCE} = 500μA	0.8 × V _{CC}		
		(_T, _S, _R versions only), V _{CC1} > V _{TH1} (MAX), V _{CC2} > V _{TH2} (MAX)	I _{SOURCE} = 800μA	V _{CC} - 1.5		
WATCHDOG INPUT (MAX6358/MAX6359/MAX6360)						
Watchdog Timeout Period	t _{WD}	First timeout period after reset	25.6	46.4	72.0	s
		After first WDI falling edge	1.6	2.9	4.5	
WDI Pulse Width (Note 4)	t _{WDI}	V _{IL} = 0.4V, V _{IH} = 0.8 × V _{CC}	50			ns
WDI Input Voltage (Note 5)	V _{IL}	V _{CC1} = 5V	0.3 × V _{CC}			V
	V _{IH}		0.7 × V _{CC}			
WDI Input Current (Note 6)		V _{WDI} = V _{CC}	120	160		μA
		V _{WDI} = 0	-20	-15		
MANUAL RESET INPUT						
$\overline{\text{MR}}$ Input Voltage	V _{IL}	MAX63_ _L_, MAX63_ _M_, V _{CC1} > V _{TH1} (MAX)	0.8			V
	V _{IH}	MAX63_ _L_, MAX63_ _M_, V _{CC1} > V _{TH1} (MAX)	2.3			
	V _{IL}	MAX63_ _ _Y, V _{CC1} > V _{TH1} (MAX)	0.3 × V _{CC}			
	V _{IH}	MAX63_ _ _Y, V _{CC1} > V _{TH1} (MAX)	0.7 × V _{CC}			

Dual/Triple-Voltage µP Supervisory Circuits

ELECTRICAL CHARACTERISTICS (continued)

(V_{CC1} = V_{CC2} = +1.2V to +5.5V, T_A = -40°C to +85°C, unless otherwise noted. Typical values are at T_A = +25°C.) (Note 1)

PARAMETER	SYMBOL	CONDITIONS	MIN	TYP	MAX	UNITS	
\overline{MR} Pullup Resistance			32	63.5	100	kΩ	
\overline{MR} Minimum Pulse Width	t _{RP}		1			µs	
\overline{MR} Glitch Rejection				100		ns	
\overline{MR} to Reset Delay	t _{MD}			0.1		µs	
ADJUSTABLE RESET COMPARATOR INPUT (MAX6355/MAX6356/MAX6357)							
RSTIN Input Threshold	V _{RSTIN}	V _{CC1} > V _{TH1} (MAX), V _{CC2} > V _{TH2} (MAX)	T _A = +25°C	1.20	1.22	1.24	V
			T _A = -40°C to +85°C	1.19		1.25	
RSTIN Input Current	I _{RSTIN}	0 < V _{RSTIN} < V _{CC1} - 0.3V	-25		25	nA	
RSTIN Hysteresis				2.5		mV	

Note 1: Overtemperature limits are guaranteed by design and not production tested.

Note 2: The reset output is guaranteed to be in the correct state if either V_{CC1} or V_{CC2} is within its specified region of operation.

Note 3: The reset output(s) is asserted if either V_{CC1} or V_{CC2} drops below its associated trip point.

Note 4: Guaranteed by design. Not production tested.

Note 5: WDI is internally serviced within the watchdog timeout period if WDI is left unconnected.

Note 6: The WDI input current is specified as the average input current when the WDI input is driven high or low.

Typical Operating Characteristics

(V_{CC1} = +5V, T_A = +25°C, unless otherwise noted.)

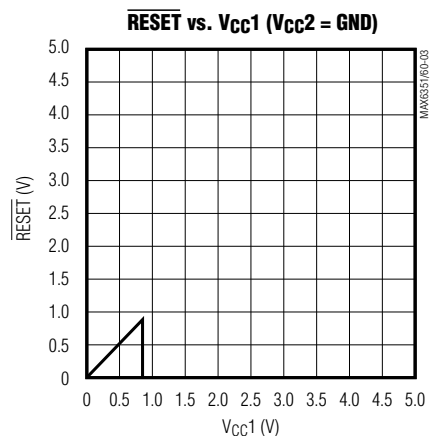
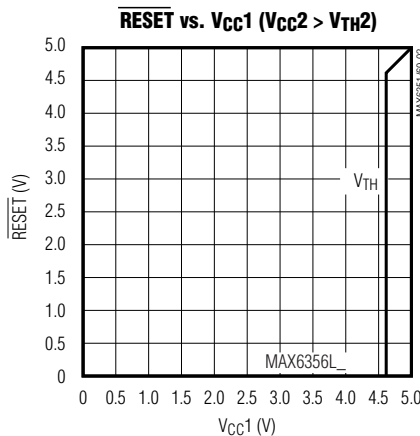
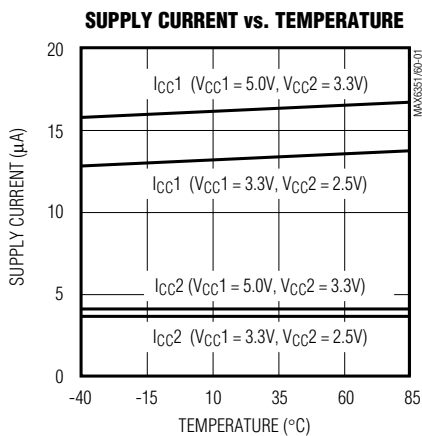

Dual/Triple-Voltage μ P Supervisory Circuits

MAX6351-MAX6360

Typical Operating Characteristics (continued)

($V_{CC1} = +5V$, $T_A = +25^\circ C$, unless otherwise noted.)

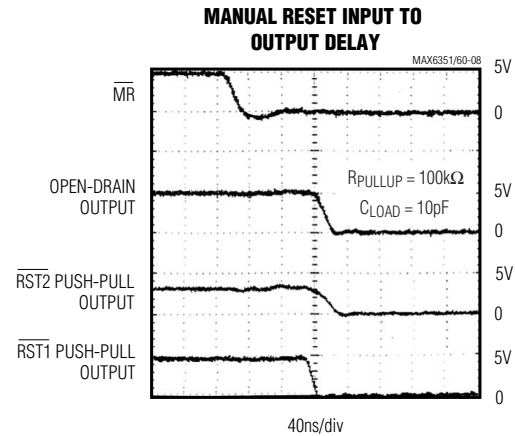
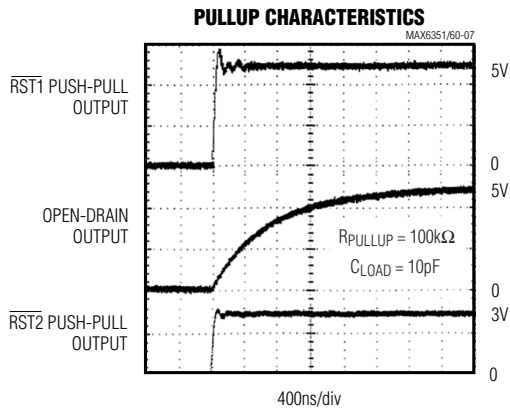
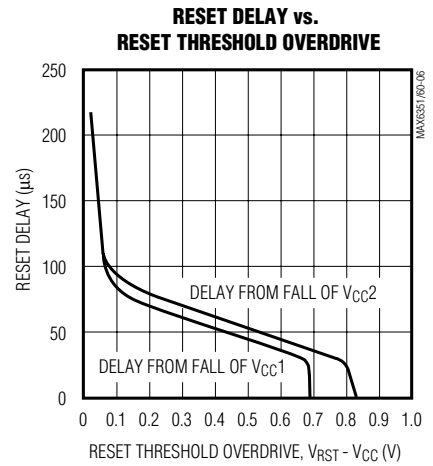
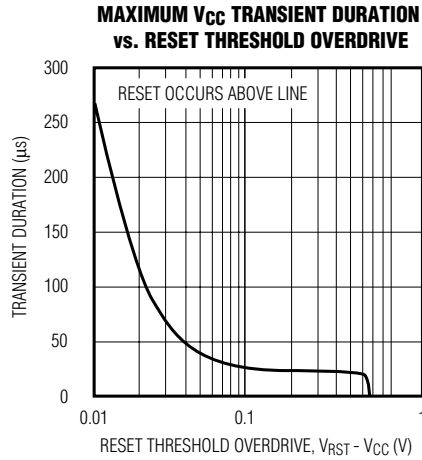
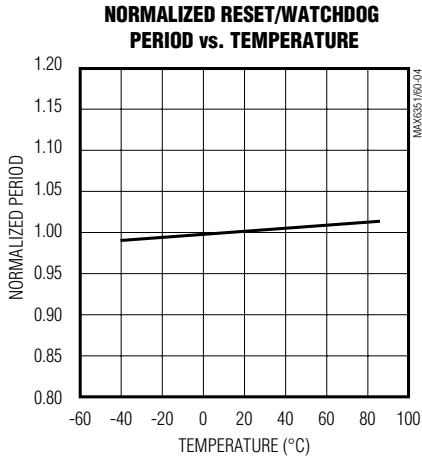

Dual/Triple-Voltage μP Supervisory Circuits

MAX6351-MAX6360

Pin Description

PIN				NAME	FUNCTION
MAX6351	MAX6352 MAX6353 MAX6354	MAX6355 MAX6356 MAX6357	MAX6358 MAX6359 MAX6360		
1	—	—	—	$\overline{\text{RST}}_1$	Active-Low, CMOS Reset Output Referenced to V_{CC1}
—	1	1	1	$\overline{\text{RST}}$	Active-Low Reset Output. Open drain for the MAX6352/MAX6355/MAX6358, push-pull with respect to V_{CC1} for the MAX6353/MAX6356/MAX6359, and push-pull with respect to V_{CC2} for the MAX6354/MAX6357/MAX6360.
2	2	2	2	GND	Ground
3	3	3	3	$\overline{\text{MR}}$	Manual-Reset Input. Pull low to force a reset. $\overline{\text{RST}}$, $\overline{\text{RST}}_1$, and $\overline{\text{RST}}_2$ remain active as long as $\overline{\text{MR}}$ is low and for the timeout period after $\overline{\text{MR}}$ goes high. Leave unconnected or connect to V_{CC1} if unused. $V_{\overline{\text{MR}}}$ must not exceed V_{CC1} .
4	4	4	4	V_{CC2}	Supply Input. Powers the device when it is above V_{CC1} and monitors its own voltage.
5	—	—	—	$\overline{\text{RST}}_2$	Active-Low, CMOS Reset Output Referenced to V_{CC2}
—	—	5	—	RSTIN	Undervoltage Reset Comparator Input. Asserts reset when the monitored voltage falls below 1.22V. Set the reset threshold with an external resistive divider. Connect to V_{CC1} if unused. V_{RSTIN} must not exceed V_{CC1} .
—	—	—	5	WDI	Watchdog Input. If WDI remains either high or low longer than the timeout period, then reset is triggered. The timer clears when reset is asserted or whenever WDI sees a rising or falling edge. Leave floating to disable it if unused.
6	5	6	6	V_{CC1}	Supply Input. Powers the device when it is above V_{CC2} and monitors its own voltage.

Dual/Triple-Voltage μ P Supervisory Circuits

Detailed Description

Supply Voltages

The MAX6351-MAX6360 microprocessor (μ P) supervisory circuits maintain system integrity by alerting the μ P to fault conditions. These ICs monitor multiple-supply systems. The output reset state is guaranteed to remain viable while either V_{CC1} or V_{CC2} is above +1V.

Threshold Levels

All the possible input voltage threshold level combinations are indicated by a two-letter code in the *Voltage Threshold Levels* table.

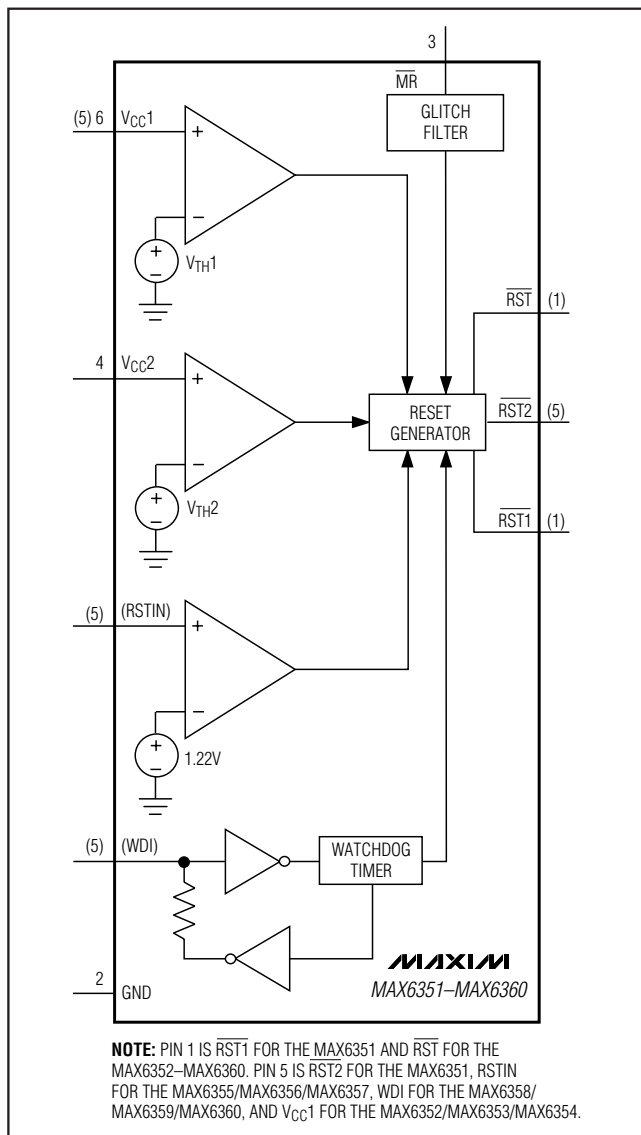

Figure 1. Functional Diagram

Reset Outputs

The MAX6351 provides two active-low, push-pull reset outputs, one corresponding to each of its two monitored voltages. The MAX6353/MAX6356/MAX6359 have an active-low, push-pull reset output that is referenced to V_{CC1} . The MAX6354/MAX6357/MAX6360 have an active-low, push-pull reset output that is referenced to V_{CC2} . The MAX6352/MAX6355/MAX6358 provide an active-low open-drain reset. The reset outputs are maintained as long as at least one of the supplies is above +1V.

Negative-Going V_{CC} Transients

The MAX6351-MAX6360 are designed to ignore short negative-going V_{CC1} and V_{CC2} transients. See the Maximum V_{CC} Transient Duration vs. Reset Threshold Overdrive graph in the *Typical Operating Characteristics*.

Third Input Voltage (MAX6355/MAX6356/MAX6357)

The MAX6355/MAX6356/MAX6357 provide an additional input to monitor a third voltage. The threshold voltage at RSTIN is typically 1.22V. To monitor a voltage higher than 1.22V, connect a resistive divider to the circuit as shown in Figure 2. The threshold at V_{EXT} is:

$$V_{EXT_TH} = 1.22V \left(\frac{R1 + R2}{R2} \right)$$

Note that RSTIN is powered by V_{CC1} , and its voltage must therefore remain lower than or equal to V_{CC1} .

Watchdog Input (MAX6358/MAX6359/MAX6360)

The MAX6358/MAX6359/MAX6360 include a dual-mode watchdog timer to monitor μ P activity. The flexible timeout architecture provides a startup mode, allowing complicated systems to complete lengthy boots, and a normal mode, allowing the supervisor to provide quick alerts when processor activity fails.

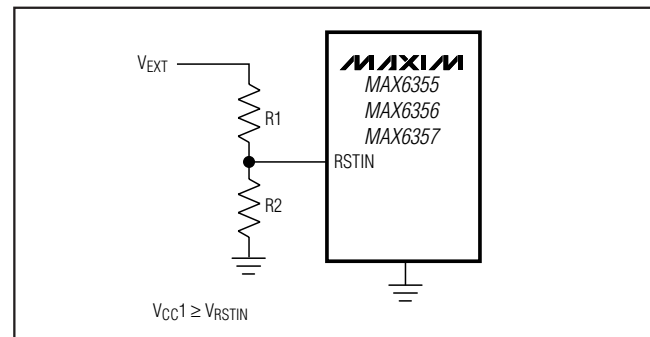

Figure 2. Monitoring a Third Voltage

Dual/Triple-Voltage μ P Supervisory Circuits

During the normal operating mode, the supervisor will issue a reset pulse for the reset timeout period (140ms min) if the μ P does not update the WDI with a valid transition (HIGH to LOW or LOW to HIGH) within the standard timeout period (1.6s min).

After each reset event (V_{CC} power-up, manual reset, or watchdog reset), there is an initial watchdog startup timeout period of 25.6s. The startup mode provides an extended period for the system to power up and fully initialize all μ P and system components before assuming responsibility for routine watchdog updates. The normal watchdog timeout period (1.6s min) begins at the conclusion of the startup timeout period or after the first transition on WDI before the conclusion of the startup period (Figure 3).

Applications Information

Ensuring a Valid $\overline{\text{RESET}}$ Output Down to $V_{CC} = 0$

In some systems, it is necessary to ensure a valid reset even if V_{CC} falls to 0. In these applications, use the circuit shown in Figure 4. Note that this configuration does not work for the open-drain outputs of the MAX6352/MAX6355/MAX6358.

Interfacing to μ Ps with Bidirectional Reset Pins

Microprocessors with bidirectional reset pins will contend with the push-pull outputs of these devices. To prevent this, connect a 4.7k Ω resistor between $\overline{\text{RESET}}$ and the μ P's reset I/O port, as shown in Figure 5. Buffer $\overline{\text{RESET}}$ as shown in the figure if this reset is used by other components in the system.

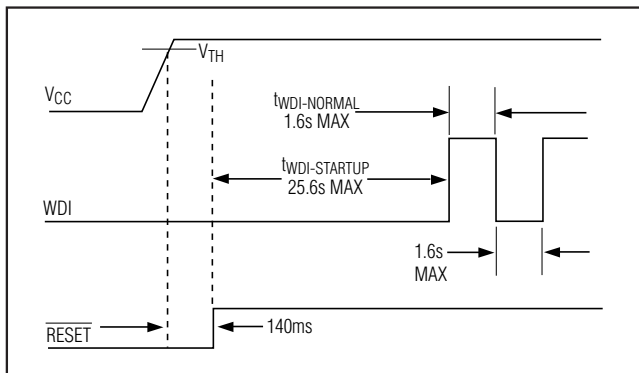

Figure 3. Normal Watchdog Startup Sequence

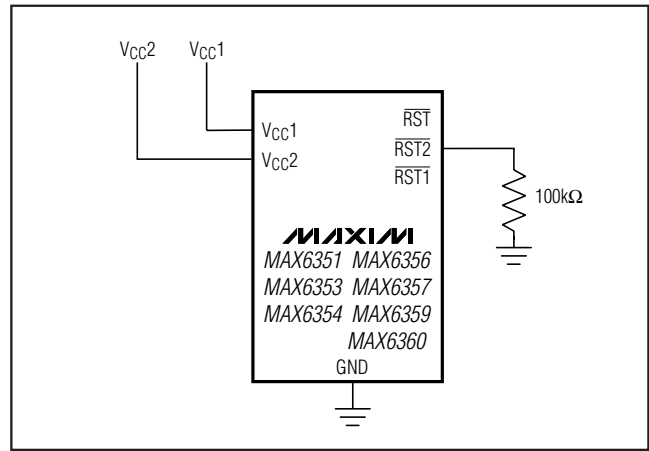

Figure 4. Ensuring a Valid Reset Low to V_{CC1} and $V_{CC2} = 0$

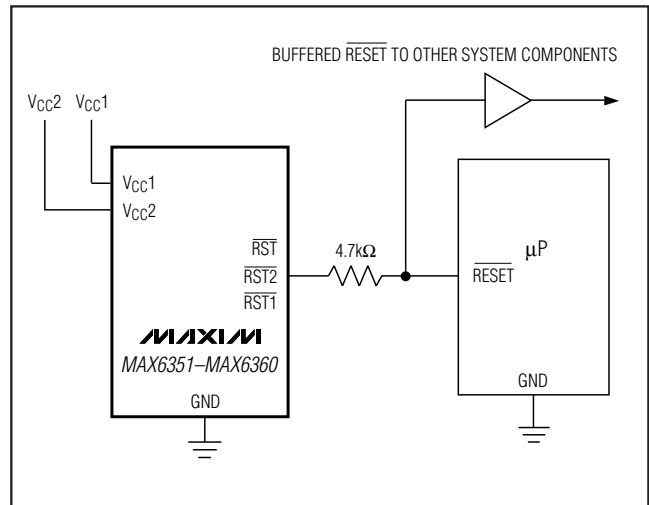

Figure 5. Interfacing to μ Ps with Bidirectional Reset I/O

Chip Information

TRANSISTOR COUNT: 855

Dual/Triple-Voltage μ P Supervisory Circuits

Pin Configurations

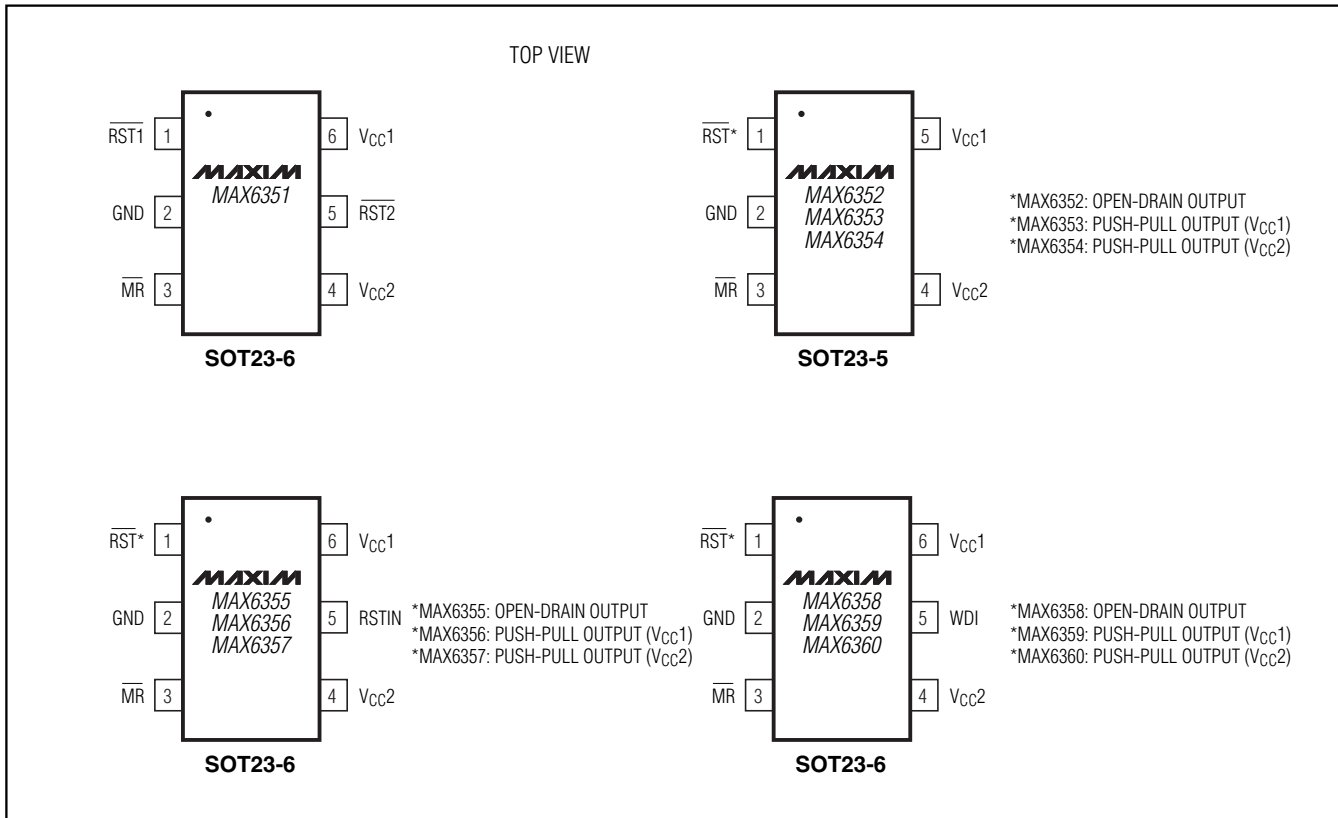

Selector Guide

PART	PIN COUNT	NUMBER OF SUPPLIES MONITORED	$\overline{\text{RST1}}$	$\overline{\text{RST2}}$	OPEN-DRAIN RESET	WATCHDOG TIMER	MANUAL RESET
MAX6351	6	2	✓	✓	—	—	✓
MAX6352	5	2	—	—	✓	—	✓
MAX6353	5	2	✓	—	—	—	✓
MAX6354	5	2	—	✓	—	—	✓
MAX6355	6	3	—	—	✓	—	✓
MAX6356	6	3	✓	—	—	—	✓
MAX6357	6	3	—	✓	—	—	✓
MAX6358	6	2	—	—	✓	✓	✓
MAX6359	6	2	✓	—	—	✓	✓
MAX6360	6	2	—	✓	—	✓	✓

Dual/Triple-Voltage μP Supervisory Circuits

Package Information

(The package drawing(s) in this data sheet may not reflect the most current specifications. For the latest package outline information, go to www.maxim-ic.com/packages.)

SYMBOL	MIN	MAX
A	0.90	1.45
A1	0.00	0.15
A2	0.90	1.30
b	0.35	0.50
C	0.08	0.20
D	2.80	3.00
E	2.60	3.00
E1	1.50	1.75
L	0.35	0.60
L1	0.60	REF.
e1	1.90	BSC.
e	0.95	BSC.
a	0°	10°

NOTES:

- ALL DIMENSIONS ARE IN MILLIMETERS.
- FOOT LENGTH MEASURED AT INTERCEPT POINT BETWEEN DATUM A & LEAD SURFACE.
- PACKAGE OUTLINE EXCLUSIVE OF MOLD FLASH & METAL BURR. MOLD FLASH, PROTRUSION OR METAL BURR SHOULD NOT EXCEED 0.25 MM.
- PACKAGE OUTLINE INCLUSIVE OF SOLDER PLATING.
- PIN 1 IS LOWER LEFT PIN WHEN READING TOP MARK FROM LEFT TO RIGHT. (SEE EXAMPLE TOP MARK)
- PIN 1 I.D. DOT IS 0.3 MM Ø MIN. LOCATED ABOVE PIN 1.
- MEETS JEDEC MO17B, VARIATION AB.
- SOLDER THICKNESS MEASURED AT FLAT SECTION OF LEAD BETWEEN 0.08mm AND 0.15mm FROM LEAD TIP.
- LEAD TO BE COPLANAR WITHIN 0.1 MM.

6L SOT.EPS

-DRAWING NOT TO SCALE-

TITLE PACKAGE OUTLINE, SOT 6L BODY		
APPROVAL	DOCUMENT CONTROL NO. 21-0058	REV. G 1/1

Dual/Triple-Voltage μP Supervisory Circuits

Package Information (continued)

(The package drawing(s) in this data sheet may not reflect the most current specifications. For the latest package outline information, go to www.maxim-ic.com/packages.)

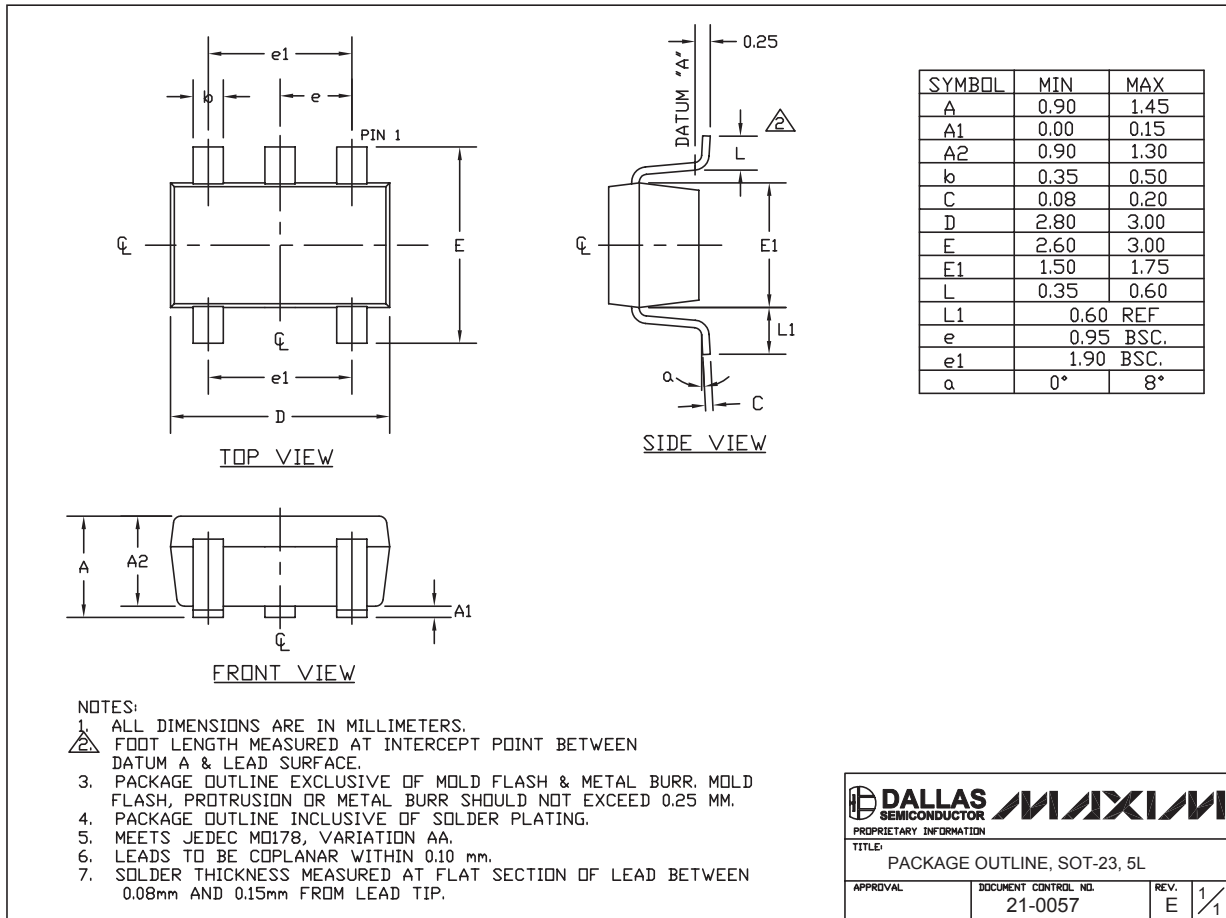

SOT-23 5L .EPS

MAX6351-MAX6360

Maxim cannot assume responsibility for use of any circuitry other than circuitry entirely embodied in a Maxim product. No circuit patent licenses are implied. Maxim reserves the right to change the circuitry and specifications without notice at any time.

11 **Maxim Integrated Products, 120 San Gabriel Drive, Sunnyvale, CA 94086 408-737-7600**