

Dual, 256-Tap, Nonvolatile, SPI-Interface, Linear-Taper Digital Potentiometers

General Description

The MAX5487/MAX5488/MAX5489 dual, linear-taper, digital potentiometers function as mechanical potentiometers with a simple 3-wire SPI™-compatible digital interface that programs the wipers to any one of 256 tap positions. These digital potentiometers feature a nonvolatile memory (EEPROM) to return the wipers to their previously stored positions upon power-up.

The MAX5487 has an end-to-end resistance of 10kΩ, while the MAX5488 and MAX5489 have resistances of 50kΩ and 100kΩ, respectively. These devices have a low 35ppm/°C end-to-end temperature coefficient, and operate from a single +2.7V to +5.25V supply.

The MAX5487/MAX5488/MAX5489 are available in 16-pin 3mm x 3mm x 0.8mm TQFN or 14-pin TSSOP packages. Each device is guaranteed over the extended -40°C to +85°C temperature range.

Applications

LCD Screen Adjustment
Audio Volume Control
Mechanical Potentiometer Replacement
Low-Drift Programmable Filters
Low-Drift Programmable-Gain Amplifiers

Features

- ◆ Wiper Position Stored in Nonvolatile Memory (EEPROM) and Recalled Upon Power-Up or Recalled by an Interface Command
- ◆ 3mm x 3mm x 0.8mm, 16-Pin TQFN or 14-Pin TSSOP Packages
- ◆ ±1 LSB INL, ±0.5 LSB DNL (Voltage-Divider Mode)
- ◆ 256 Tap Positions
- ◆ 35ppm/°C End-to-End Resistance Temperature Coefficient
- ◆ 5ppm/°C Ratiometric Temperature Coefficient
- ◆ 10kΩ, 50kΩ, and 100kΩ End-to-End Resistance Values
- ◆ SPI-Compatible Serial Interface
- ◆ Reliability
 - 200,000 Wiper Store Cycles
 - 50-Year Wiper Data Retention
- ◆ +2.7V to +5.25V Single-Supply Operation

SPI is a trademark of Motorola, Inc.

Ordering Information

PART	TEMP RANGE	PIN-PACKAGE	END-TO-END RESISTANCE (kΩ)	TOP MARK
MAX5487ETE+	-40°C to +85°C	16 TQFN-EP*	10	ABR
MAX5487EUD+	-40°C to +85°C	14 TSSOP	10	—

*EP = Exposed pad.

+Denotes a lead(Pb)-free/RoHS-compliant package.

Ordering Information continued at end of data sheet.

Functional Diagram

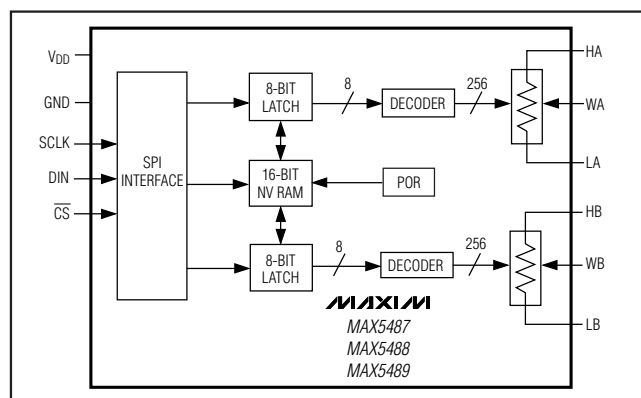

Pin Configurations

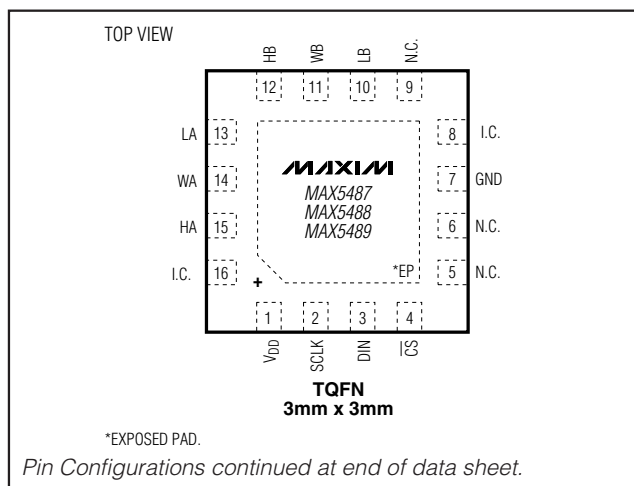

Dual, 256-Tap, Nonvolatile, SPI-Interface, Linear-Taper Digital Potentiometers

ABSOLUTE MAXIMUM RATINGS

V _{DD} to GND	-0.3V to +6.0V
All Other Pins to GND	-0.3V to the lower of (V _{DD} + 0.3V) and +6.0V
Maximum Continuous Current into H ₋ , W ₋ , and L ₋	
MAX5487	±5.0mA
MAX5488	±1.3mA
MAX5489	±0.6mA

Continuous Power Dissipation (T _A = +70°C)	
16-Pin TQFN (derate 17.5mW/°C above +70°C)	1398mW
14-Pin TSSOP (derate 9.1mW/°C above +70°C)	727mW
Operating Temperature Range	-40°C to +85°C
Junction Temperature	+150°C
Storage Temperature Range	-60°C to +150°C
Lead Temperature (soldering, 10s)	+300°C
Soldering Temperature (reflow)	+260°C

Stresses beyond those listed under "Absolute Maximum Ratings" may cause permanent damage to the device. These are stress ratings only, and functional operation of the device at these or any other conditions beyond those indicated in the operational sections of the specifications is not implied. Exposure to absolute maximum rating conditions for extended periods may affect device reliability.

DC ELECTRICAL CHARACTERISTICS

(V_{DD} = +2.7V to +5.25V, V_H = V_{DD}, V_L = GND, T_A = -40°C to +85°C, unless otherwise noted. Typical values are at V_{DD} = +5.0V, T_A = +25°C, unless otherwise noted.) (Note 1)

PARAMETER	SYMBOL	CONDITIONS	MIN	TYP	MAX	UNITS	
DC PERFORMANCE (Voltage-Divider Mode, Figure 1)							
Resolution	N		256			Taps	
Integral Nonlinearity	INL	(Note 2)			±1	LSB	
Differential Nonlinearity	DNL	(Note 2)			±0.5	LSB	
Dual-Code Matching		Register A = register B			2	LSB	
End-to-End Resistor Tempco	TC _R			35		ppm/°C	
Ratiometric Resistor Tempco				5		ppm/°C	
Full-Scale Error		MAX5487		3.5	6	LSB	
		MAX5488		-0.6	+1.2		
		MAX5489		-0.3	+1.2		
Zero-Scale Error		MAX5487		3.5	6	LSB	
		MAX5488		-0.6	1.5		
		MAX5489		0.3	1		
DC PERFORMANCE (Variable-Resistor Mode, Figure 1)							
Resolution			256			Taps	
Integral Nonlinearity (Note 3)		V _{DD} = 5.0V			±1.5	LSB	
		V _{DD} = 3.0V			±3		
Differential Nonlinearity (Note 3)		V _{DD} = 5.0V			±1	LSB	
		V _{DD} = 3.0V			±1		
DC PERFORMANCE (Resistor Characteristics)							
Wiper Resistance (Note 4)	R _W	V _{DD} = 5.0V		200	350	Ω	
		V _{DD} = 3.0V		325	675		
Wiper Capacitance	C _W			50		pF	
End-to-End Resistance	R _{HL}	MAX5487		7.5	10	12.5	kΩ
		MAX5488		37.5	50	62.5	
		MAX5489		75	100	125	

Dual, 256-Tap, Nonvolatile, SPI-Interface, Linear-Taper Digital Potentiometers

MAX5487/MAX5488/MAX5489

DC ELECTRICAL CHARACTERISTICS (continued)

($V_{DD} = +2.7V$ to $+5.25V$, $V_H = V_{DD}$, $V_L = GND$, $T_A = -40^{\circ}C$ to $+85^{\circ}C$, unless otherwise noted. Typical values are at $V_{DD} = +5.0V$, $T_A = +25^{\circ}C$, unless otherwise noted.) (Note 1)

PARAMETER	SYMBOL	CONDITIONS	MIN	TYP	MAX	UNITS
DIGITAL INPUTS						
Input High Voltage (Note 5)	V_{IH}	$V_{DD} = 3.6V$ to $5.25V$	2.4			V
		$V_{DD} = 2.7V$ to $3.6V$	$0.7 \times V_{DD}$			
Input Low Voltage	V_{IL}	$V_{DD} = 2.7V$ to $5.25V$ (Note 5)			0.8	V
Input Leakage Current	I_{IN}				± 1.0	μA
Input Capacitance	C_{IN}			5.0		pF
AC PERFORMANCE						
Crosstalk		$f_{H_} = 1kHz$, $L_ = GND$, measurement at $W_$ (Note 6)		-90		dB
-3dB Bandwidth	BW	Wiper at midscale $C_{W_} = 10pF$	MAX5487	350		kHz
			MAX5488	90		
			MAX5489	45		
Total Harmonic Distortion	THD	$V_{H_} = 1V_{RMS}$ at $1kHz$, $L_ = GND$, measurement at $W_$		0.02		%
TIMING CHARACTERISTICS (Analog)						
Wiper-Settling Time	t_s	Code 0 to 127 (Note 7)	MAX5487	0.5		μs
			MAX5488	0.75		
			MAX5489	1.5		
TIMING CHARACTERISTICS (Digital, Figure 2, Note 8)						
SCLK Frequency					5	MHz
SCLK Clock Period	t_{CP}		200			ns
SCLK Pulse-Width High	t_{CH}		80			ns
SCLK Pulse-Width Low	t_{CL}		80			ns
\overline{CS} Fall to SCLK Rise Setup	t_{CSS}		80			ns
SCLK Rise to \overline{CS} Rise Hold	t_{CSH}		0			ns
DIN to SCLK Setup	t_{DS}		50			ns
DIN Hold after SCLK	t_{DH}		0			ns
SCLK Rise to \overline{CS} Fall Delay	t_{CS0}		20			ns
\overline{CS} Rise to SCLK Rise Hold	t_{CS1}		80			ns
\overline{CS} Pulse-Width High	t_{CSW}		200			ns
Write NV Register Busy Time	t_{BUSY}				12	ms
Read NV Register Access Time	t_{ACC}				1	μs
Write Wiper Register to Output Delay	t_{WO}				1	μs
NONVOLATILE MEMORY RELIABILITY						
Data Retention		$T_A = +85^{\circ}C$		50		Years
Endurance		$T_A = +25^{\circ}C$		200,000		Stores
		$T_A = +85^{\circ}C$		50,000		

Dual, 256-Tap, Nonvolatile, SPI-Interface, Linear-Taper Digital Potentiometers

DC ELECTRICAL CHARACTERISTICS (continued)

($V_{DD} = +2.7V$ to $+5.25V$, $V_H = V_{DD}$, $V_L = GND$, $T_A = -40^{\circ}C$ to $+85^{\circ}C$, unless otherwise noted. Typical values are at $V_{DD} = +5.0V$, $T_A = +25^{\circ}C$, unless otherwise noted.) (Note 1)

PARAMETER	SYMBOL	CONDITIONS	MIN	TYP	MAX	UNITS
POWER SUPPLIES						
Power-Supply Voltage	V_{DD}		2.70		5.25	V
Supply Current	I_{DD}	During write cycle only, digital inputs = V_{DD} or GND			400	μA
Standby Current		Digital inputs = V_{DD} or GND, $T_A = +25^{\circ}C$		0.5	1	μA

- Note 1:** All devices are production tested at $T_A = +85^{\circ}C$ and are guaranteed by design and characterization for $-40^{\circ}C < T_A < +85^{\circ}C$.
- Note 2:** DNL and INL are measured with the potentiometer configured as a voltage-divider with $H_+ = V_{DD}$ and $L_- = 0$. The wiper terminal is unloaded and measured with an ideal voltmeter.
- Note 3:** DNL and INL are measured with the potentiometer configured as a variable resistor. H_+ is unconnected and $L_- = 0$. For $V_{DD} = +5V$, the wiper terminal is driven with a source current of $400\mu A$ for the $10k\Omega$ configuration, $80\mu A$ for the $50k\Omega$ configuration, and $40\mu A$ for the $100k\Omega$ configuration. For $V_{DD} = +3V$, the wiper terminal is driven with a source current of $200\mu A$ for the $10k\Omega$ configuration, $40\mu A$ for the $50k\Omega$ configuration, and $20\mu A$ for the $100k\Omega$ configuration.
- Note 4:** The wiper resistance is the worst value measured by injecting the currents given in Note 3 into W_+ with $L_- = GND$. $R_W = (V_W - V_H) / I_W$.
- Note 5:** The device draws higher supply current when the digital inputs are driven with voltages between $(V_{DD} - 0.5V)$ and $(GND + 0.5V)$. See Supply Current vs. Digital Input Voltage in the *Typical Operating Characteristics* section.
- Note 6:** Wiper at midscale with a $10pF$ load.
- Note 7:** Wiper-settling time is the worst-case 0-to-50% rise time, measured between tap 0 and tap 127. $H_+ = V_{DD}$, $L_- = GND$, and the wiper terminal is unloaded and measured with a $10pF$ oscilloscope probe (see Tap-to-Tap Switching Transient in the *Typical Operating Characteristics* section).
- Note 8:** Digital timing is guaranteed by design and characterization, and is not production tested.

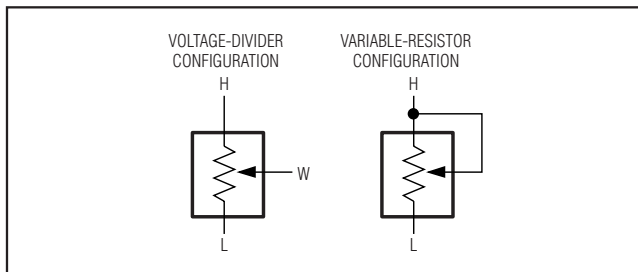

Figure 1. Voltage-Divider/Variable-Resistor Configurations

Dual, 256-Tap, Nonvolatile, SPI-Interface, Linear-Taper Digital Potentiometers

Typical Operating Characteristics

($V_{DD} = +5.0V$, $T_A = +25^\circ C$, unless otherwise noted.)

MAX5487/MAX5488/MAX5489

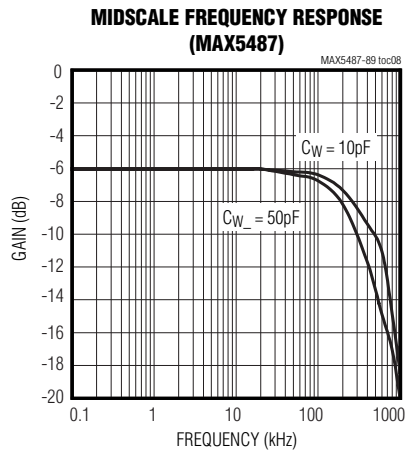
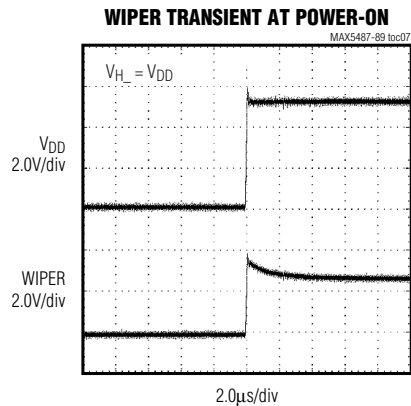
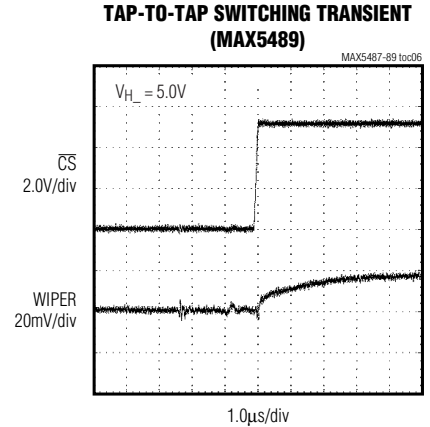
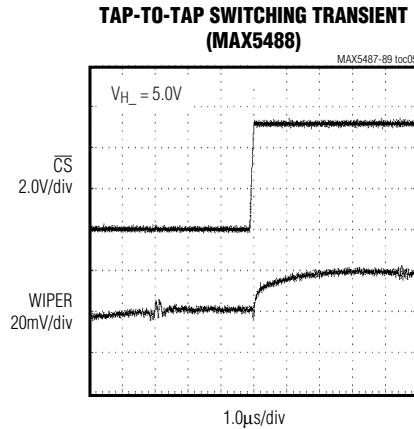
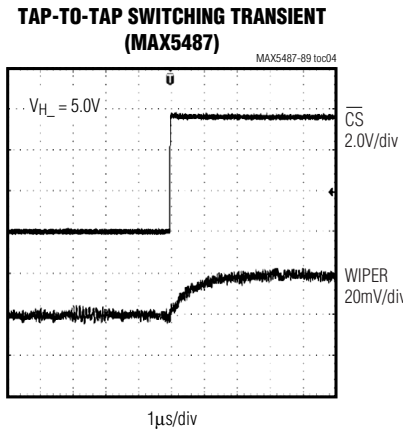
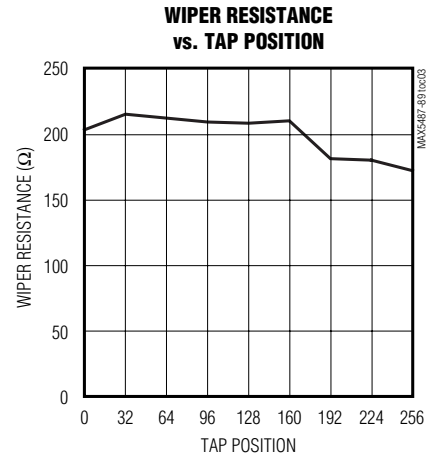
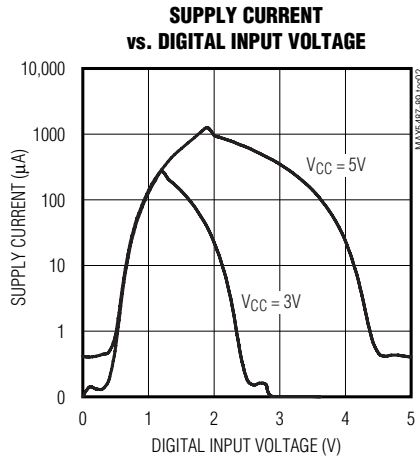
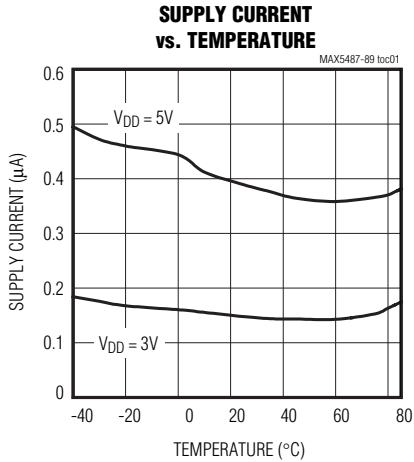

Dual, 256-Tap, Nonvolatile, SPI-Interface, Linear-Taper Digital Potentiometers

Typical Operating Characteristics (continued)

($V_{DD} = +5.0V$, $T_A = +25^\circ C$, unless otherwise noted.)

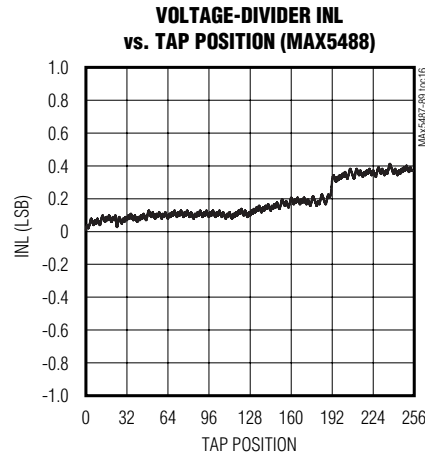
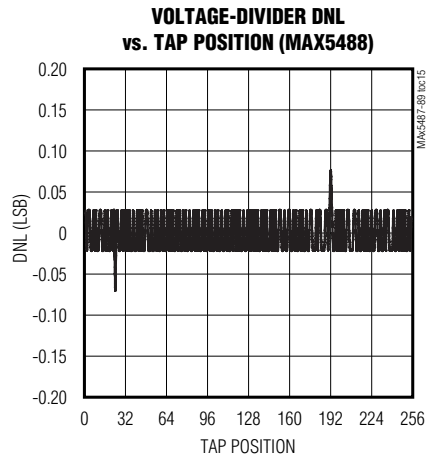
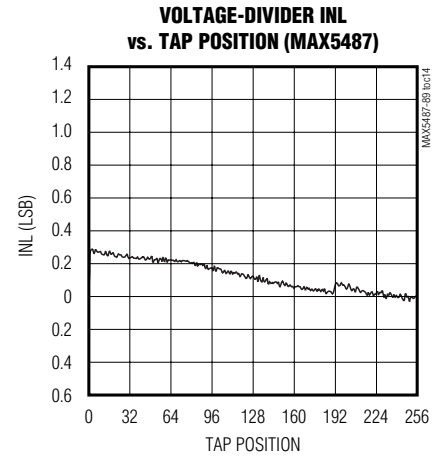
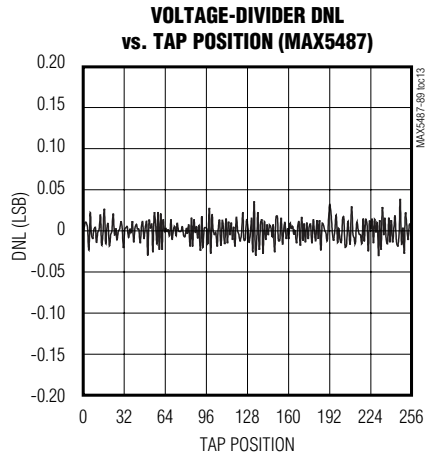
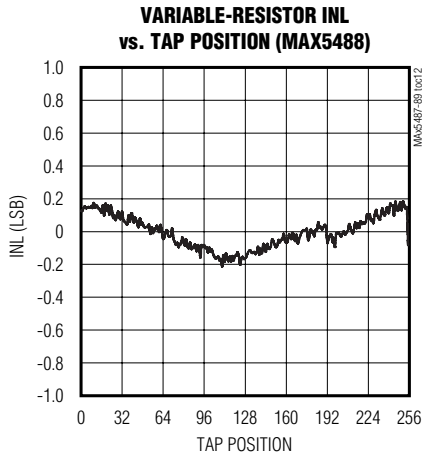
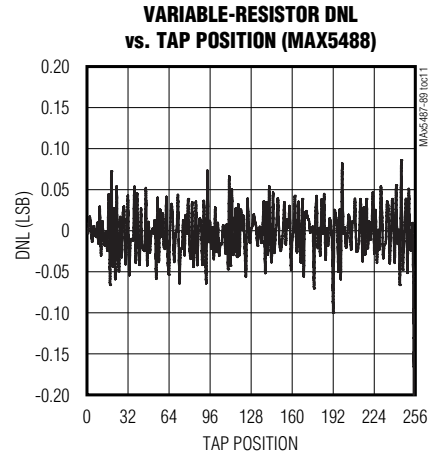
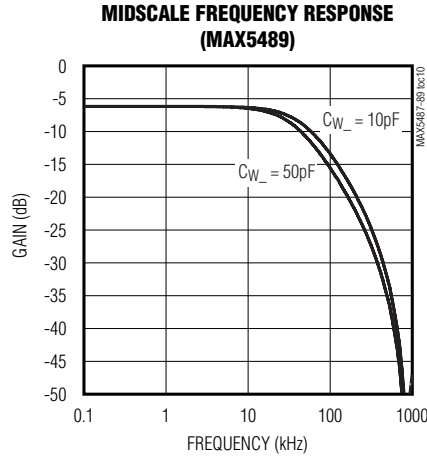
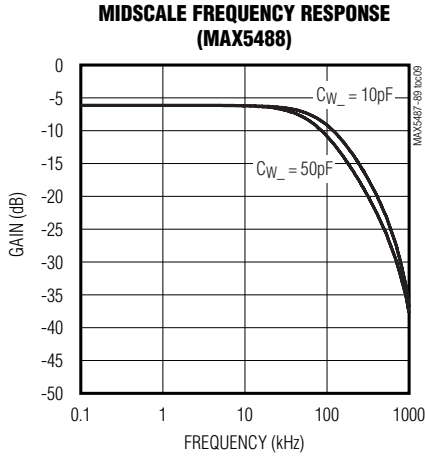

Dual, 256-Tap, Nonvolatile, SPI-Interface, Linear-Taper Digital Potentiometers

Typical Operating Characteristics (continued)

($V_{DD} = +5.0V$, $T_A = +25^\circ C$, unless otherwise noted.)

MAX5487/MAX5488/MAX5489

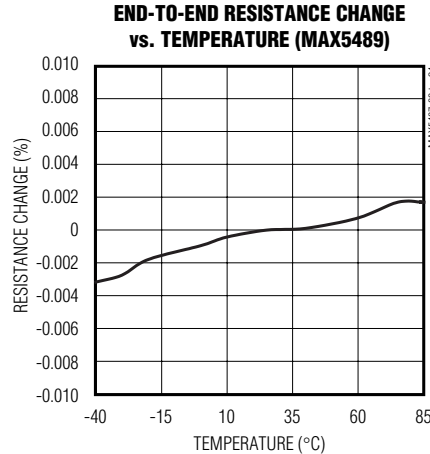
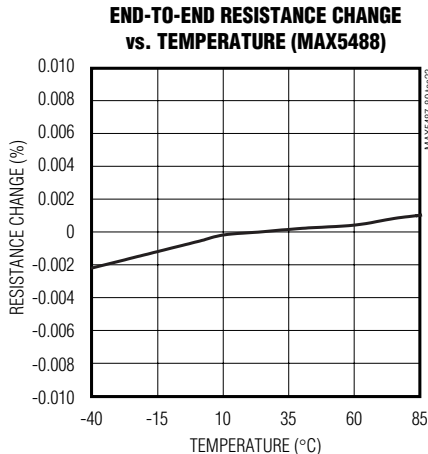
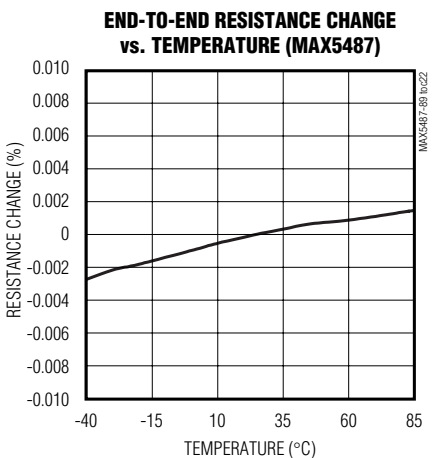
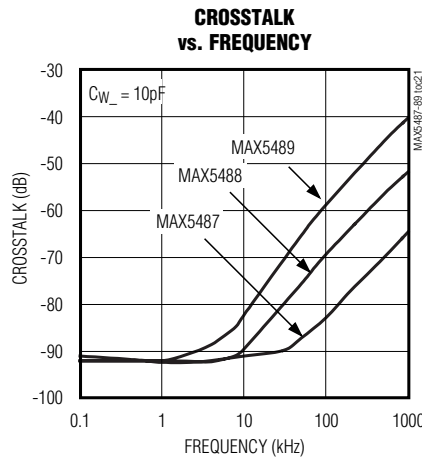
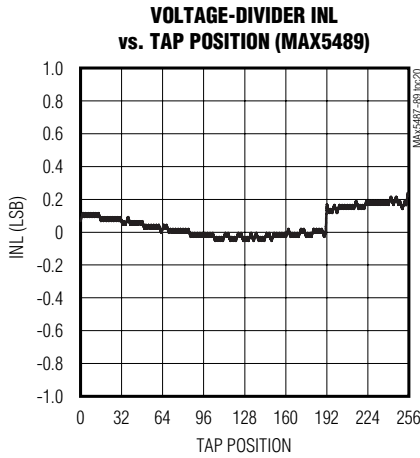
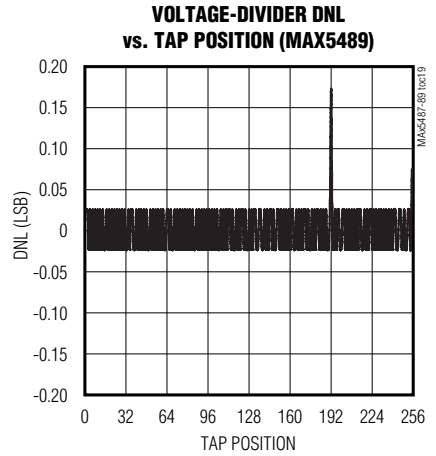
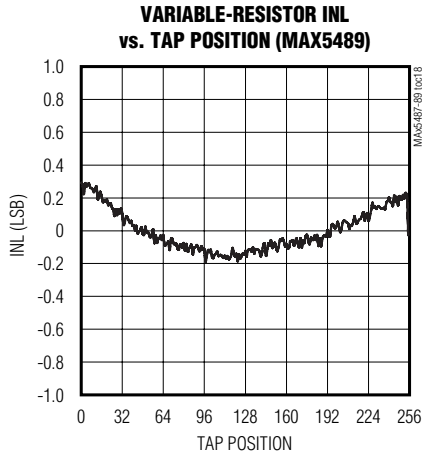
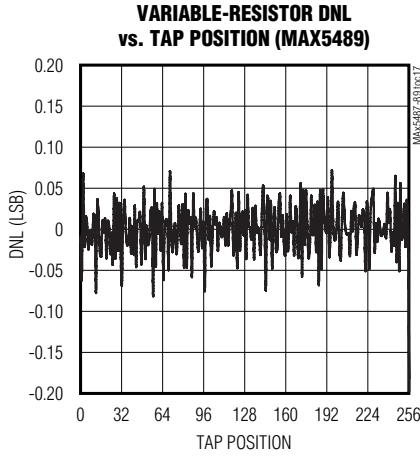

Dual, 256-Tap, Nonvolatile, SPI-Interface, Linear-Taper Digital Potentiometers

Pin Description

PIN		NAME	FUNCTION
TQFN	TSSOP		
1	14	V _{DD}	Power Supply. Bypass V _{DD} to GND with a 0.1μF capacitor as close to the device as possible.
2	13	SCLK	Serial-Interface Clock Input
3	12	DIN	Serial-Interface Data Input
4	11	\overline{CS}	Active-Low Chip-Select Digital Input
5, 6, 9	7, 9, 10	N.C.	No Connection. Not internally connected.
7	8	GND	Ground
8, 16	—	I.C.	Internally connected to EP. Leave unconnected.
10	6	LB	Low Terminal of Resistor B. The voltage at L can be greater than or less than the voltage at H. Current can flow into or out of L.
11	5	WB	Wiper Terminal of Resistor B
12	4	HB	High Terminal of Resistor B. The voltage at H can be greater than or less than the voltage at L. Current can flow into or out of H.
13	3	LA	Low Terminal of Resistor A. The voltage at L can be greater than or less than the voltage at H. Current can flow into or out of L.
14	2	WA	Wiper Terminal of Resistor A
15	1	HA	High Terminal of Resistor A. The voltage at H can be greater than or less than the voltage at L. Current can flow into or out of H.
—	—	EP	Exposed Pad (TQFN only). Internally connected to pins 8 and 16. Leave unconnected.

Detailed Description

The MAX5487/MAX5488/MAX5489 contain two resistor arrays, with 255 resistive elements each. The MAX5487 has an end-to-end resistance of 10kΩ, while the MAX5488 and MAX5489 have resistances of 50kΩ and 100kΩ, respectively. The MAX5487/MAX5488/MAX5489 allow access to the high, low, and wiper terminals on both potentiometers for a standard voltage-divider configuration. Connect the wiper to the high terminal, and connect the low terminal to ground, to make the device a variable resistor (see Figure 1).

A simple 3-wire serial interface programs either wiper directly to any of the 256 tap points. The nonvolatile memory stores the wiper position prior to power-down and recalls the wiper to the same point upon power-up or by using an interface command (see Table 1). The nonvolatile memory is guaranteed for 200,000 wiper store cycles and 50 years for wiper data retention.

SPI Digital Interface

The MAX5487/MAX5488/MAX5489 use a 3-wire SPI-compatible serial data interface (Figures 2 and 3). This write-only interface contains three inputs: chip-select

(\overline{CS}), data clock (SCLK), and data in (DIN). Drive \overline{CS} low to enable the serial interface and clock data synchronously into the shift register on each SCLK rising edge.

The WRITE commands (C1, C0 = 00 or 01) require 16 clock cycles to clock in the command, address, and data (Figure 3a). The COPY commands (C1, C0 = 10, 11) can use either eight clock cycles to transfer only command and address bits (Figure 3b) or 16 clock cycles, with the device disregarding 8 data bits (Figure 3a).

After loading data into the shift register, drive \overline{CS} high to latch the data into the appropriate potentiometer control register and disable the serial interface. Keep \overline{CS} low during the entire serial data stream to avoid corruption of the data.

Digital-Interface Format

The data format consists of three elements: command bits, address bits, and data bits (see Table 1 and Figure 3). The command bits (C1 and C0) indicate the action to be taken such as changing or storing the wiper position. The address bits (A1 and A0) specify which potentiometer the command affects and the 8 data bits (D7 to D0) specify the wiper position.

Dual, 256-Tap, Nonvolatile, SPI-Interface, Linear-Taper Digital Potentiometers

MAX5487/MAX5488/MAX5489

Table 1. Register Map

CLOCK EDGE	1	2	3	4	5	6	7	8	9	10	11	12	13	14	15	16
	—	—	C1	C0	—	—	A1	A0	D7	D6	D5	D4	D3	D2	D1	D0
Write Wiper Register A	0	0	0	0	0	0	0	1	D7	D6	D5	D4	D3	D2	D1	D0
Write Wiper Register B	0	0	0	0	0	0	1	0	D7	D6	D5	D4	D3	D2	D1	D0
Write NV Register A	0	0	0	1	0	0	0	1	D7	D6	D5	D4	D3	D2	D1	D0
Write NV Register B	0	0	0	1	0	0	1	0	D7	D6	D5	D4	D3	D2	D1	D0
Copy Wiper Register A to NV Register A	0	0	1	0	0	0	0	1	—	—	—	—	—	—	—	—
Copy Wiper Register B to NV Register B	0	0	1	0	0	0	1	0	—	—	—	—	—	—	—	—
Copy Both Wiper Registers to NV Registers	0	0	1	0	0	0	1	1	—	—	—	—	—	—	—	—
Copy NV Register A to Wiper Register A	0	0	1	1	0	0	0	1	—	—	—	—	—	—	—	—
Copy NV Register B to Wiper Register B	0	0	1	1	0	0	1	0	—	—	—	—	—	—	—	—
Copy Both NV Registers to Wiper Registers	0	0	1	1	0	0	1	1	—	—	—	—	—	—	—	—

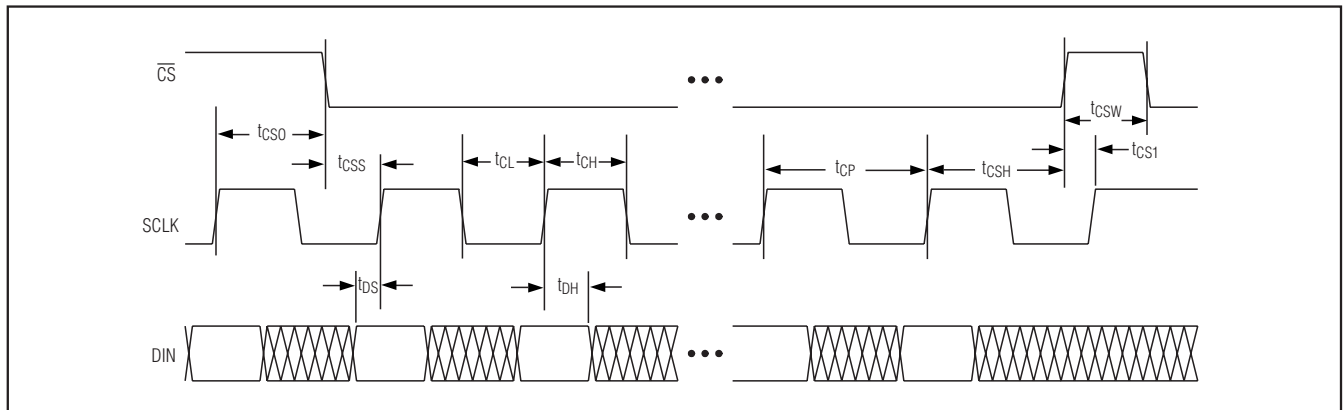

Figure 2. Timing Diagram

Write-Wiper Register (Command 00)

Data written to the write-wiper registers (C1, C0 = 00) controls the wiper positions. The 8 data bits (D7 to D0) indicate the position of the wiper. For example, if DIN = 0000 0000, the wiper moves to the position closest to L₋. If DIN = 1111 1111, the wiper moves closest to H₋.

This command writes data to the volatile RAM, leaving the NV registers unchanged. When the device powers up, the data stored in the NV registers transfers to the volatile wiper register, moving the wiper to the stored position.

Write-NV Register (Command 01)

This command (C1, C0 = 01) stores the position of the wipers to the NV registers for use at power-up. Alternatively, the "copy wiper register to NV register" command can be used to store the position of the wipers to the NV registers. Writing to the NV registers does not affect the position of the wipers.

Copy Wiper Register to NV Register (Command 10)

This command (C1, C0 = 10) stores the current position of the wiper to the NV register, for use at power-up. This command may affect one potentiometer at a time,

Dual, 256-Tap, Nonvolatile, SPI-Interface, Linear-Taper Digital Potentiometers

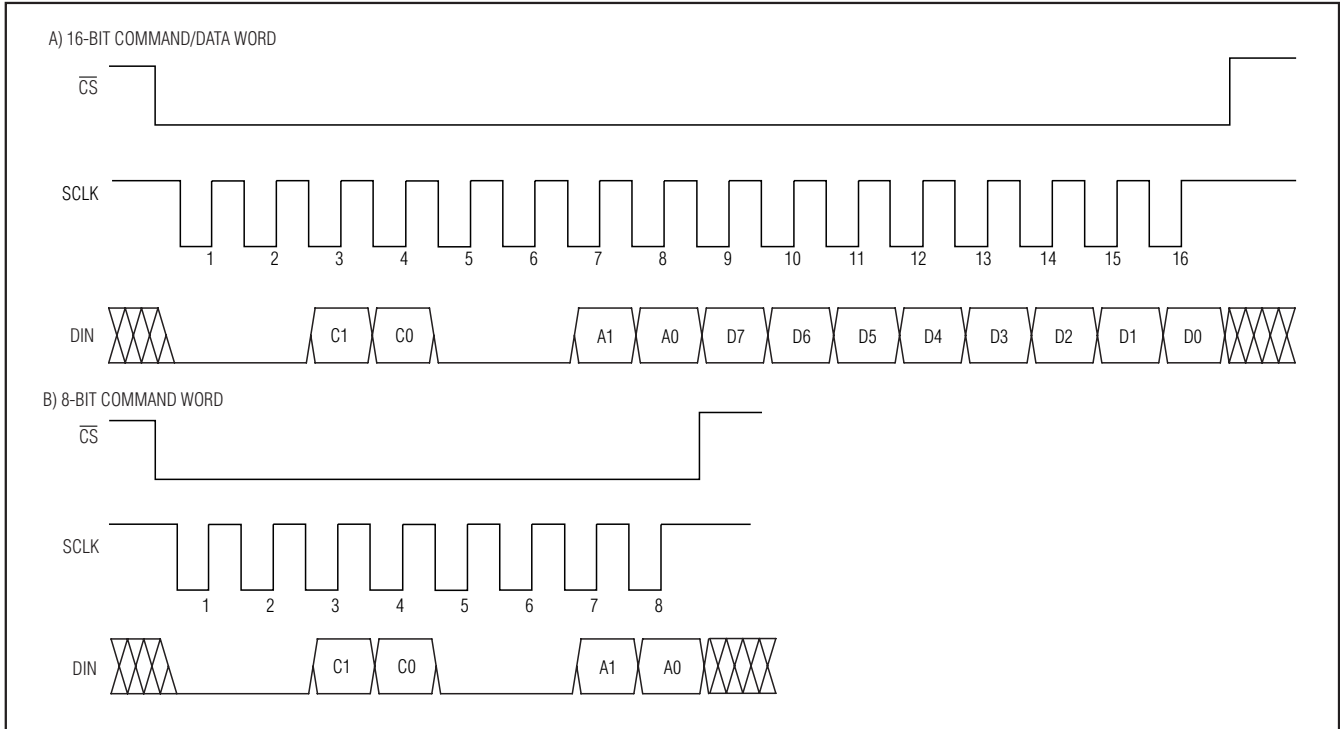

Figure 3. Digital-Interface Format

or both simultaneously, depending on the state of A1 and A0. Alternatively, the “write NV register” command can be used to store the current position of the wiper to the NV register.

Copy NV Register to Wiper Register (Command 11)

This command (C1, C0 = 11) restores the wiper position to the previously stored position in the NV register. This command may affect one potentiometer at a time, or both simultaneously, depending on the state of A1 and A0.

Nonvolatile Memory

The internal EEPROM consists of a nonvolatile register that retains the last stored value prior to power-down. The nonvolatile register is programmed to midscale at the factory. The nonvolatile memory is guaranteed for 200,000 wiper write cycles and 50 years for wiper data retention.

Power-Up

Upon power-up, the MAX5487/MAX5488/MAX5489 load the data stored in the nonvolatile wiper register into the volatile memory register, updating the wiper position with the data stored in the nonvolatile wiper register. This initialization period takes 5 μ s.

Standby

The MAX5487/MAX5488/MAX5489 feature a low-power standby mode. When the device is not being programmed, it enters into standby mode and supply current drops to 0.5 μ A (typ).

Applications Information

The MAX5487/MAX5488/MAX5489 are ideal for circuits requiring digitally controlled adjustable resistance, such as LCD contrast control (where voltage biasing adjusts the display contrast), or for programmable filters with adjustable gain and/or cutoff frequency.

Positive LCD Bias Control

Figures 4 and 5 show an application where the MAX5487/MAX5488/MAX5489 provide an adjustable, positive LCD-bias voltage. The op amp provides buffering and gain to the resistor-divider network made by the potentiometer (Figure 4) or by a fixed resistor and a variable resistor (Figure 5).

Programmable Filter

Figure 6 shows the MAX5487/MAX5488/MAX5489 in a 1st-order programmable-filter application. Adjust the gain of the filter with R₂, and set the cutoff frequency with R₃.

Dual, 256-Tap, Nonvolatile, SPI-Interface, Linear-Taper Digital Potentiometers

MAX5487/MAX5488/MAX5489

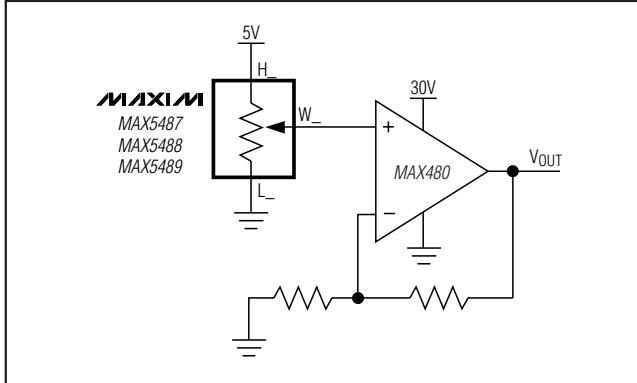

Figure 4. Positive LCD-Bias Control Using a Voltage-Divider

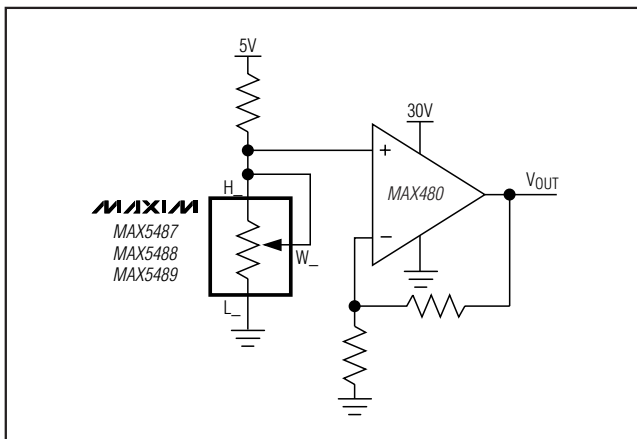

Figure 5. Positive LCD-Bias Control Using a Variable Resistor

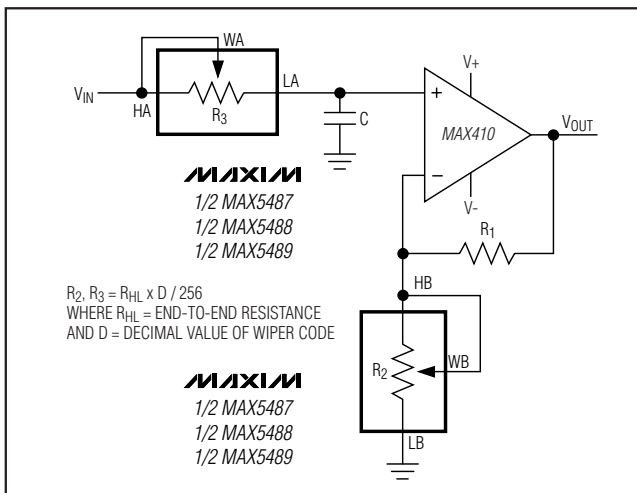

Figure 6. Programmable Filter

Use the following equations to calculate the gain (A) and the -3dB cutoff frequency (f_c):

$$A = 1 + \frac{R_1}{R_2}$$

$$f_c = \frac{1}{2\pi \times R_3 \times C}$$

Adjustable Voltage Reference

Figure 7 shows the MAX5487/MAX5488/MAX5489 used as the feedback resistors in multiple adjustable voltage-reference applications. Independently adjust the output voltages of the MAX6160s from 1.23V to $V_{IN} - 0.2V$ by changing the wiper positions of the MAX5487/MAX5488/MAX5489.

Offset Voltage and Gain Adjustment

Connect the high and low terminals of one potentiometer of a MAX5487/MAX5488/MAX5489 to the NULL inputs of a MAX410, and connect the wiper to the op amp's positive supply to nullify the offset voltage over the operating temperature range. Install the other potentiometer in the feedback path to adjust the gain of the MAX410 (see Figure 8).

Chip Information

PROCESS: BiCMOS

Pin Configurations (continued)

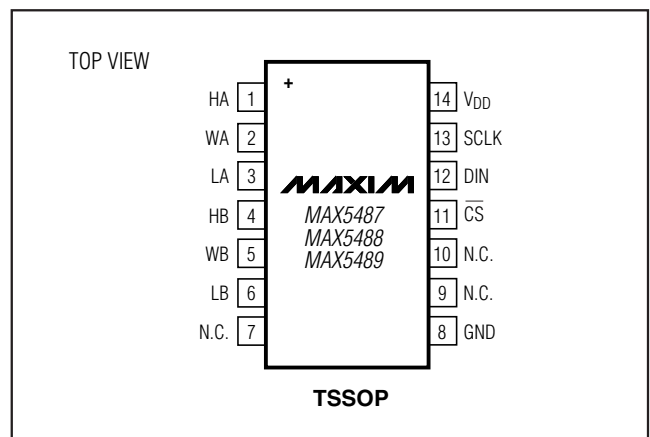

Dual, 256-Tap, Nonvolatile, SPI-Interface, Linear-Taper Digital Potentiometers

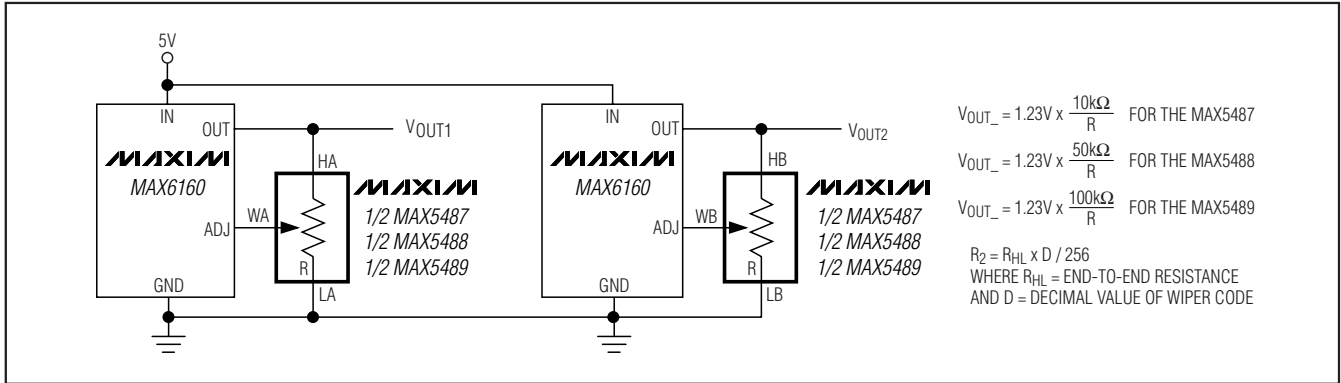

Figure 7. Adjustable Voltage Reference

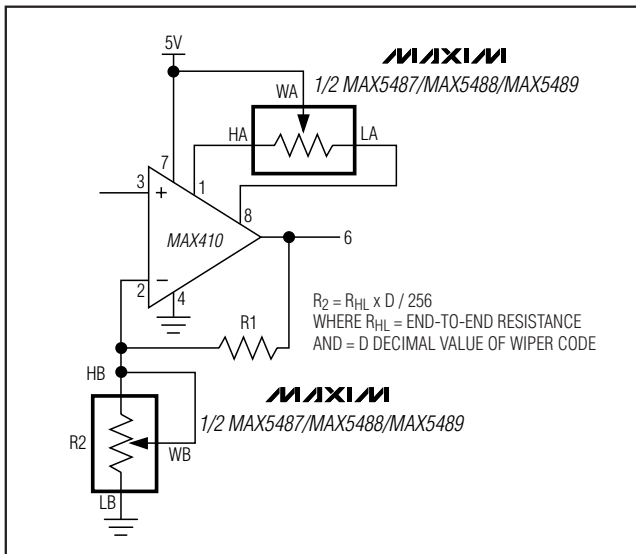

Figure 8. Offset Voltage and Gain Adjustment

Package Information

For the latest package outline information and land patterns, go to www.maxim-ic.com/packages. Note that a "+", "#", or "-" in the package code indicates RoHS status only. Package drawings may show a different suffix character, but the drawing pertains to the package regardless of RoHS status.

PACKAGE TYPE	PACKAGE CODE	OUTLINE NO.	LAND PATTERN NO.
16 TQFN-EP	T1633F+3	21-0136	90-0033
14 TSSOP	U14+1	21-0066	90-0113

Ordering Information (continued)

PART	TEMP RANGE	PIN-PACKAGE	END-TO-END RESISTANCE (kΩ)	TOP MARK
MAX5488ETE+	-40°C to +85°C	16 TQFN-EP*	50	ABS
MAX5488EUD+	-40°C to +85°C	14 TSSOP	50	—
MAX5489ETE+	-40°C to +85°C	16 TQFN-EP*	100	ABT
MAX5489EUD+	-40°C to +85°C	14 TSSOP	100	—
MAX5489ETE/V+	-40°C to +85°C	16 TQFN-EP*	100	AIE

*EP = Exposed pad.

+Denotes a lead(Pb)-free/RoHS-compliant package.

/V denotes an automotive qualified part.

Dual, 256-Tap, Nonvolatile, SPI-Interface, Linear-Taper Digital Potentiometers

Revision History

REVISION NUMBER	REVISION DATE	DESCRIPTION	PAGES CHANGED
3	1/07	—	1, 8, 12, 15
4	4/10	Updated <i>Ordering Information</i> (added lead-free packaging and automotive qualified part, released TSSOP package), and updated <i>Absolute Maximum Ratings</i>	1, 2, 12

MAX5487/MAX5488/MAX5489

Maxim cannot assume responsibility for use of any circuitry other than circuitry entirely embodied in a Maxim product. No circuit patent licenses are implied. Maxim reserves the right to change the circuitry and specifications without notice at any time.

Maxim Integrated Products, 120 San Gabriel Drive, Sunnyvale, CA 94086 408-737-7600 _____ 13