



Low-Voltage, Dual-Supply, SPST, CMOS Analog Switches

MAX4503/MAX4504

General Description

The MAX4503/MAX4504 are low-voltage, dual-supply, single-pole/single-throw (SPST), CMOS analog switches. The MAX4503 is normally open (NO). The MAX4504 is normally closed (NC).

These CMOS switches can operate continuously with dual supplies between $\pm 1.5V$ and $\pm 6V$. Each switch can handle rail-to-rail analog signals. The off-leakage current is only 1nA at +25°C or 10nA at +85°C.

The digital input is CMOS-logic compatible when using $\pm 5V$ supplies. A unique logic input architecture allows this even though the parts have no ground pin.

For single-supply operation, use the MAX4501/MAX4502, which are pin-for-pin equivalents.

Features

- ◆ Available in SOT23-5 Package
- ◆ Dual-Supply Operation from $\pm 1V$ to $\pm 6V$
- ◆ Guaranteed On-Resistance: **250Ω with $\pm 5V$ Supplies**
- ◆ Guaranteed Low Off-Leakage Currents: **1nA at +25°C**
10nA at +85°C
- ◆ Guaranteed Low On-Leakage Currents: **2nA at +25°C**
20nA at +85°C
- ◆ Guaranteed Low Charge Injection: **10pC Max**
- ◆ Fast Switching Speed: **t_{ON} = 150ns, t_{OFF} = 100ns**
- ◆ CMOS-Logic Compatible Input

Applications

- Battery-Operated Equipment
- Audio and Video Signal Routing
- Low-Voltage Data-Acquisition Systems
- Communications Circuits
- Cellular Phones
- PCMCIA Cards
- Modems

Ordering Information

PART	TEMP. RANGE	PIN-PACKAGE
MAX4503CPA	0°C to +70°C	8 Plastic DIP
MAX4503CSA	0°C to +70°C	8 SO
MAX4503CUK	0°C to +70°C	5 SOT23-5
MAX4503C/D	0°C to +70°C	Dice*
MAX4503EPA	-40°C to +85°C	8 Plastic DIP
MAX4503ESA	-40°C to +85°C	8 SO
MAX4503EUK	-40°C to +85°C	5 SOT23-5
MAX4503MJA	-55°C to +125°C	8 CERDIP**

Ordering Information continued at end of data sheet.

* Contact factory for dice specifications.

** Contact factory for availability.

Pin Configurations

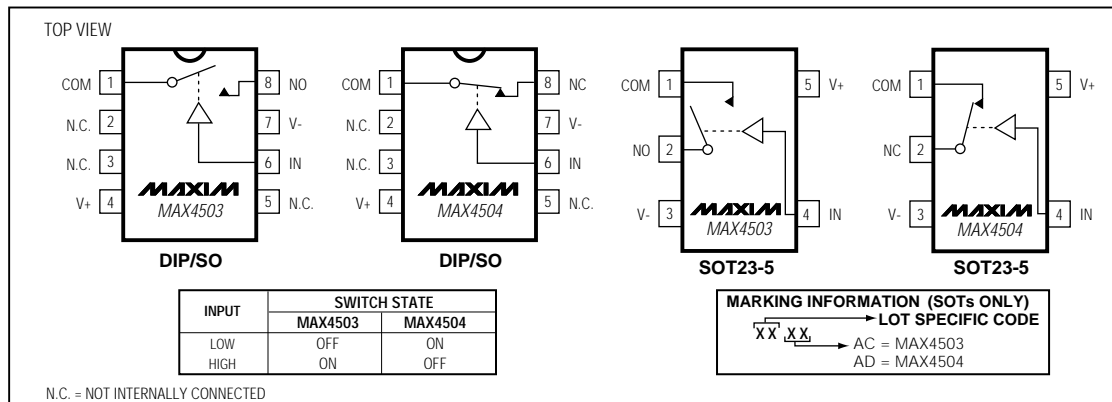

Low-Voltage, Dual-Supply, SPST, CMOS Analog Switches

ABSOLUTE MAXIMUM RATINGS

(Voltages Referenced to V₋)

V ₊	-0.3V, +13V
Voltage into Any Terminal (Note 1)	-0.3V to (V ₊ + 0.3V) or ±10mA (whichever occurs first)
Continuous Current into Any Terminal.....	±10mA
Peak Current, NO ₋ or COM ₋ (pulsed at 1ms, 10% duty cycle).....	±20mA
Continuous Power Dissipation (T _A = +70°C)	
8-Pin Plastic DIP (derate 9.09mW/°C above +70°C) ...	727mW
8-Pin SO (derate 5.88mW/°C above +70°C).....	471mW

5-Pin SOT23-5 (derate 7.1mW/°C above +70°C)	571mW
8-Pin CERDIP (derate 8.00mW/°C above +70°C).....	640mW
Operating Temperature Ranges	
MAX4503C ₋ /MAX4504C ₋	0°C to +70°C
MAX4503E ₋ /MAX4504E ₋	-40°C to +85°C
MAX4503MJA/MAX4504MJA	-55°C to +125°C
Storage Temperature Range	-65°C to +150°C
Lead Temperature (soldering, 10sec)	+300°C

Note 1: Voltages on any signal terminal exceeding V₊ or V₋ are clamped by internal diodes. Limit forward-diode current to maximum current rating.

Stresses beyond those listed under "Absolute Maximum Ratings" may cause permanent damage to the device. These are stress ratings only, and functional operation of the device at these or any other conditions beyond those indicated in the operational sections of the specifications is not implied. Exposure to absolute maximum rating conditions for extended periods may affect device reliability.

ELECTRICAL CHARACTERISTICS—±5V Supply

(V₊ = +4.5V to +5.5V, V₋ = -4.5V to -5.5V, V_{INH} = 3.5V, V_{INL} = 1.5V, T_A = T_{MIN} to T_{MAX}, unless otherwise noted. Typical values are at T_A = +25°C.)

PARAMETER	SYMBOL	CONDITIONS	MIN	TYP (Note 2)	MAX	UNITS		
ANALOG SWITCH								
Analog Signal Range	V _{COM} , V _{NO} , V _{NC}		V ₋		V ₊	V		
COM to NO or NC On-Resistance	R _{ON}	V _{COM} = 3.5V, I _{COM} = 1mA	T _A = +25°C		60	250	Ω	
			T _A = T _{MIN} to T _{MAX}			350		
NO or NC Off Leakage Current (Note 3)	I _{NO(OFF)} , I _{NC(OFF)}	V ₊ = 5.5V, V ₋ = -5.5V, V _{COM} = ±4.5V, V _{NO} or V _{NC} = ∓4.5V	T _A = +25°C		-1	0.01	1	nA
			T _A = T _{MIN} to T _{MAX}	C, E	-10	10		
				M	-100	100		
COM Off Leakage Current (Note 3)	I _{COM(OFF)}	V ₊ = 5.5V, V ₋ = -5.5V, V _{COM} = ±4.5V, V _{NO} or V _{NC} = ∓4.5V	T _A = +25°C		-1	0.01	1	nA
			T _A = T _{MIN} to T _{MAX}	C, E	-10	10		
				M	-100	100		
COM On Leakage Current (Note 3)	I _{COM(ON)}	V ₊ = 5.5V, V ₋ = -5.5V, V _{COM} = ±4.5V, V _{NO} or V _{NC} = ±4.5V	T _A = +25°C		-2	0.01	2	nA
			T _A = T _{MIN} to T _{MAX}	C, E	-20	20		
				M	-200	200		
DIGITAL I/O								
IN Input Logic High	V _{IH}		(V ₊) - 1.5		V ₊	V		
IN Input Logic Low	V _{IL}		V ₋		(V ₊) - 3.5	V		
IN Input Current Logic High or Low	I _{IH} , I _{IL}	V _{IN} = V ₊ , 0V	-1	0.03	1	μA		

Low-Voltage, Dual-Supply, SPST, CMOS Analog Switches

MAX4503/MAX4504

ELECTRICAL CHARACTERISTICS—±5V Supply (continued)

(V+ = +4.5V to +5.5V, V- = -4.5V to -5.5V, VINH = 3.5V, VINL = 1.5V, TA = TMIN to TMAX, unless otherwise noted. Typical values are at TA = +25°C.)

PARAMETER	SYMBOL	CONDITIONS	MIN	TYP (Note 2)	MAX	UNITS	
SWITCH DYNAMIC CHARACTERISTICS							
Turn-On Time	tON	VIN = 3V, RL = 1kΩ VNO or VNC = 3V, Figure 1	TA = +25°C	30	150	ns	
			TA = TMIN to TMAX		240		
Turn-Off Time	tOFF	VIN = 3V, RL = 1kΩ VNO or VNC = 3V, Figure 1	TA = +25°C	20	100	ns	
			TA = TMIN to TMAX		150		
Charge Injection (Note 4)	Q	CL = 1nF, VNO_ = 0V, RS = 0Ω, TA = +25°C, Figure 2		1	10	pC	
Off Isolation	VISO	RL = 50Ω, CL = 15pF, VNO = 1VRMS, f = 100kHz, TA = +25°C, Figure 3		<-90		dB	
NO or NC Off Capacitance	CNO(OFF)	f = 1MHz, TA = +25°C, Figure 4		3		pF	
COM Off Capacitance	COFF(COM)	f = 1MHz, TA = +25°C, Figure 4		3		pF	
COM On Capacitance	CON(COM)	f = 1MHz, TA = +25°C, Figure 4		9		pF	
POWER SUPPLY							
V+, V- Supply Current	I+, I-	VIN = 0V or V+	TA = +25°C	-125	40	125	μA
			TA = TMIN to TMAX	-200		200	

Low-Voltage, Dual-Supply, SPST, CMOS Analog Switches

ELECTRICAL CHARACTERISTICS—±3V Supply

(V+ = +2.7V to +3.3V, V- = -2.7V to -3.3V, VINH = 2.4V, VINL = 0.8V, TA = TMIN to TMAX, unless otherwise noted. Typical values are at TA = +25°C.)

PARAMETER	SYMBOL	CONDITIONS	MIN	TYP (Note 2)	MAX	UNITS	
ANALOG SWITCH							
Analog Signal Range	VCOM, VNO, VNC		0		V+	V	
COM to NO or NC On-Resistance	RON	VCOM_ = 1.5V, ICOM = 0.1mA	TA = +25°C		100	400	Ω
			TA = TMIN to TMAX			500	
NO or NC Off Leakage Current (Notes 3, 4)	INO(OFF), INC(OFF)	VCOM_ = ±1.5V, VNO or VNC = ±1.5V, V+ = 3.3V, V- = -3.3V	TA = +25°C		-1	1	nA
			TA = TMIN to TMAX	C, E	-10	10	
				M	-100	100	
COM Off Leakage Current (Notes 3, 4)	ICOM(OFF)	VCOM_ = ±1.5V, VNO or VNC = ±1.5V, V+ = 3.3V, V- = -3.3V	TA = +25°C		-1	1	nA
			TA = TMIN to TMAX	C, E	-10	10	
				M	-100	100	
COM On Leakage Current (Notes 3, 4)	ICOM(ON)	VNO or VNC = ±1.5V, VCOM_ = ±1.5V, V+ = 3.3V, V- = -3.3V	TA = +25°C		-2	2	nA
			TA = TMIN to TMAX	C, E	-20	20	
				M	-200	200	
DIGITAL I/O							
IN Input Logic High	VINH		2.4		V+	V	
IN Input Logic Low	VINL		V-		(V+) - 2.3	V	
IN Input Current Logic High or Low	I _{IH} , I _{IL}		-1	0.03	1	μA	
POWER SUPPLY							
V+, V- Supply Current	I+, I-	IN = 0V or V+	TA = +25°C		-100	25	μA
			TA = TMIN to TMAX		-175	175	

Note 2: The algebraic convention is used in this data sheet; the most negative value is shown in the minimum column.

Note 4: Guaranteed, not production tested.

Note 3: Leakage parameters are 100% tested at maximum rated hot operating temperature, and guaranteed by correlation at +25°C.

Note 5: SOT packaged parts are 100% tested at +25°C. Limits at maximum and minimum rated temperature are guaranteed by design and correlation limits at +25°C.

Low-Voltage, Dual-Supply, SPST, CMOS Analog Switches

Typical Operating Characteristics

($V_+ = +5V$, $V_- = -5V$, $T_A = +25^\circ C$, unless otherwise noted.)

MAX4503/MAX4504

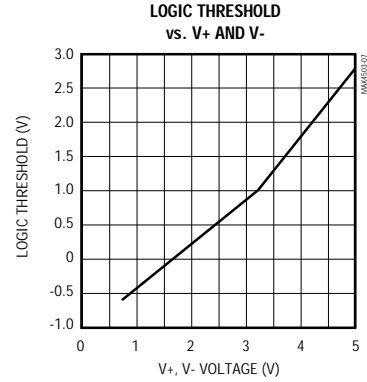
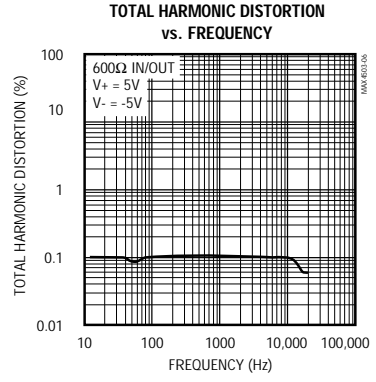
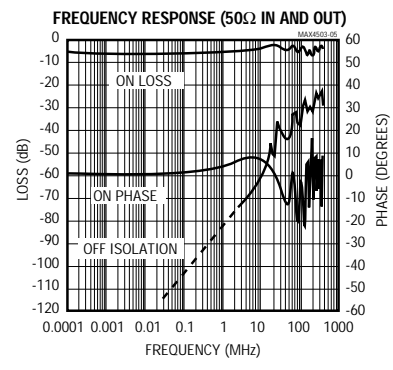
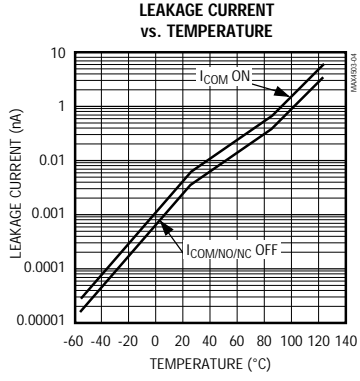
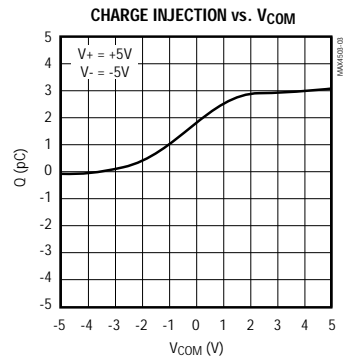
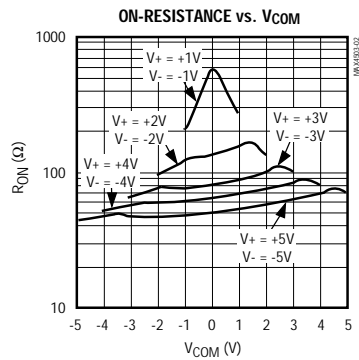
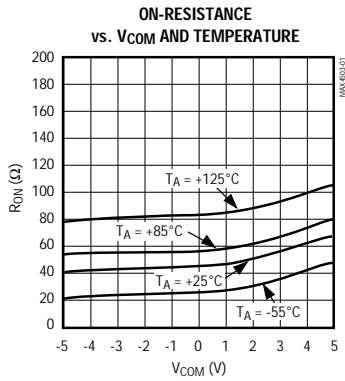

Low-Voltage, Dual-Supply, SPST, CMOS Analog Switches

Pin Description

PIN				NAME	FUNCTION
MAX4503		MAX4504			
DIP/SO	SOT23-5	DIP/SO	SOT23-5		
1	1	1	1	COM	Analog Switch Common Terminal
2, 3, 5	–	2, 3, 5	–	N.C.	No Connect (not internally connected)
4	5	4	5	V+	Positive (analog and digital) Supply Voltage Input
6	4	6	4	IN	Digital Control Input
7	3	7	3	V-	Negative (analog) Supply Voltage Input
8	2	–	–	NO	Analog Switch Normally Open Terminal
–	–	8	2	NC	Analog Switch Normally Closed Terminal

Note: NO, NC, and COM pins are identical and interchangeable. Either may be considered as an input or output; signals pass equally well in both directions.

Applications Information

Power-Supply Considerations

The MAX4503/MAX4504's construction is typical of most CMOS analog switches, except they have only two supply pins: V+ and V-. These voltages set the analog voltage limits of the switch. Reverse ESD-protection diodes are internally connected between IN and each analog signal pin and both V+ and V-. If any analog signal exceeds V+ or V-, one of these diodes will conduct. During normal operation, these (and other) reverse-biased ESD diodes leak, forming the only current drawn from V-. Additional current flows through V+ from the logic-level translator.

Virtually all the analog leakage current is provided through the ESD diodes. Although the ESD diodes on a given signal pin are identical and therefore fairly well balanced, they are reverse biased differently. Each is biased by either V+ or V- and the analog signal. This means their leakages will vary as the signal varies. The *difference* in the two diode leakages to the V+ and V- pins constitutes the analog-signal-path leakage current. All analog leakage current flows between each pin and one of the supply terminals, not to the other switch terminal. This is why both sides of a given switch can show leakage currents of either the same or opposite polarity.

There is no connection between the analog signal paths and V+ or V-.

V+ and V- also power the internal logic and logic-level translators. Since there is no ground pin, the logic input

has a low-current pull-up to V+ and the logic limit is set by an internal comparator referenced to V+. The logic-level translators convert the logic levels to switched V+ and V- signals, to drive the gates of the analog signals. This drive signal is the only connection between the logic supplies (and signals) and the analog supplies. COM, NO, and NC pins have ESD-protection diodes to V+ and V-.

The logic is CMOS compatible when V+ is +5V. CMOS compatibility is maintained with all V+ values, assuming that the CMOS logic is operated from the same V+ supply. Since the MAX4503/MAX4504 have no ground pins, the logic levels are internally referenced to V+.

Do not connect the MAX4503/MAX4504 V+ to +3V and connect the logic-level pins to TTL-logic-level signals. TTL levels can exceed +3V and violate the absolute maximum ratings, damaging the part and/or external circuits.

High-Frequency Performance

In 50Ω systems, signal response is reasonably flat up to 50MHz. (see *Typical Operating Characteristics*). Above 20MHz the on-response has several minor peaks which are highly layout dependent. The problem is not in turning the switch on, but in turning it off. The off-state switch acts like a capacitor, and passes higher frequencies with less attenuation. At 10MHz, off isolation is about -65dB in 50Ω systems, becoming worse (approximately 20dB per decade) as frequency increases. Higher circuit impedances also make off isolation worse.

Low-Voltage, Dual-Supply, SPST, CMOS Analog Switches

Test Circuits/Timing Diagrams

MAX4503/MAX4504

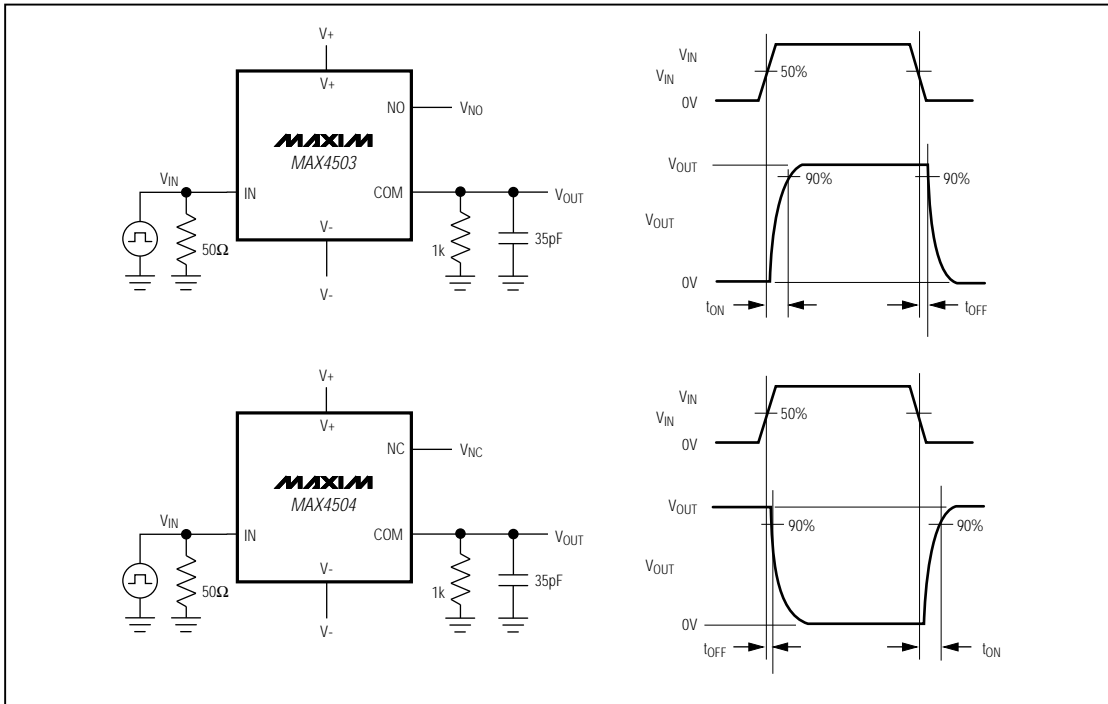

Figure 1. Switching Times

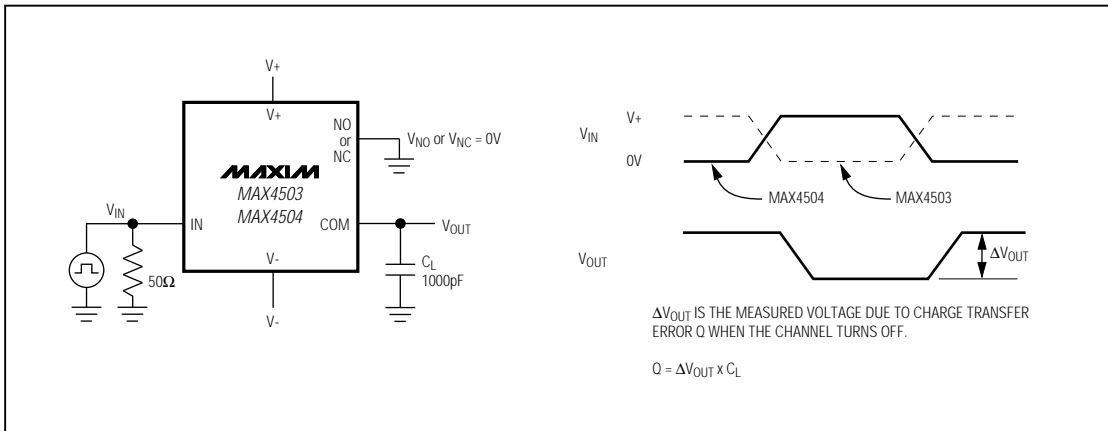

Figure 2. Charge Injection

Low-Voltage, Dual-Supply, SPST, CMOS Analog Switches

Test Circuits/Timing Diagrams (continued)

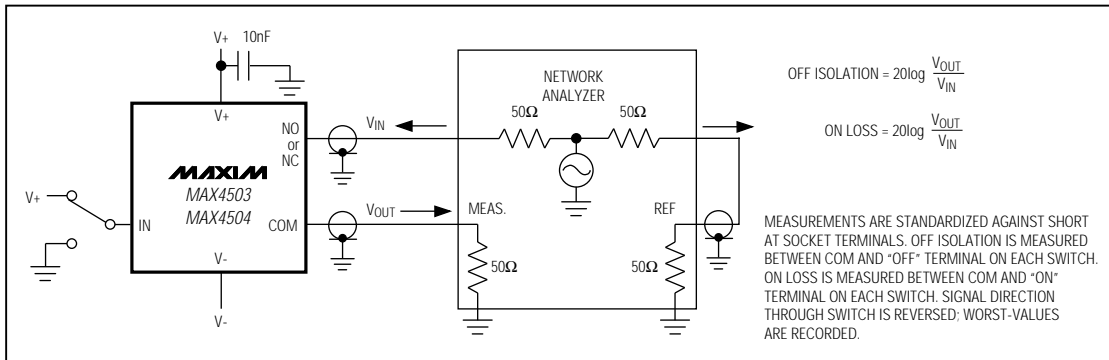

Figure 3. Off Isolation and On Loss

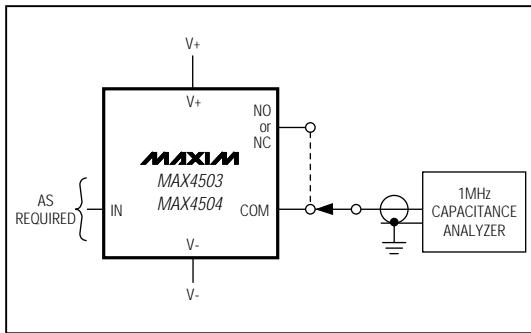

Figure 4. NO, NC, and COM Capacitance

_Ordering Information (continued)

PART	TEMP. RANGE	PIN-PACKAGE
MAX4504CPA	0°C to +70°C	8 Plastic DIP
MAX4504CSA	0°C to +70°C	8 SO
MAX4504CUK	0°C to +70°C	5 SOT23-5
MAX4504C/D	0°C to +70°C	Dice*
MAX4504EPA	-40°C to +85°C	8 Plastic DIP
MAX4504ESA	-40°C to +85°C	8 SO
MAX4504EUK	-40°C to +85°C	5 SOT23-5
MAX4504MJA	-55°C to +125°C	8 CERDIP**

* Contact factory for dice specifications.

** Contact factory for availability.

Chip Topography

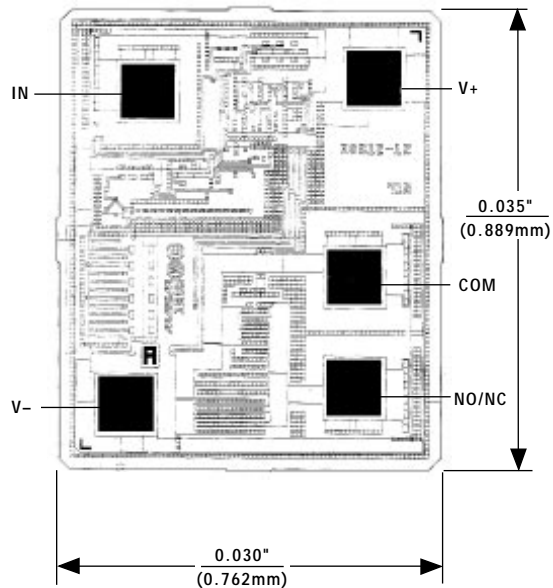

TRANSISTOR COUNT: 36

SUBSTRATE IS INTERNALLY CONNECTED TO V+

Low-Voltage, Dual-Supply, SPST, CMOS Analog Switches

Tape-and-Reel Information

MAX4503/MAX4504

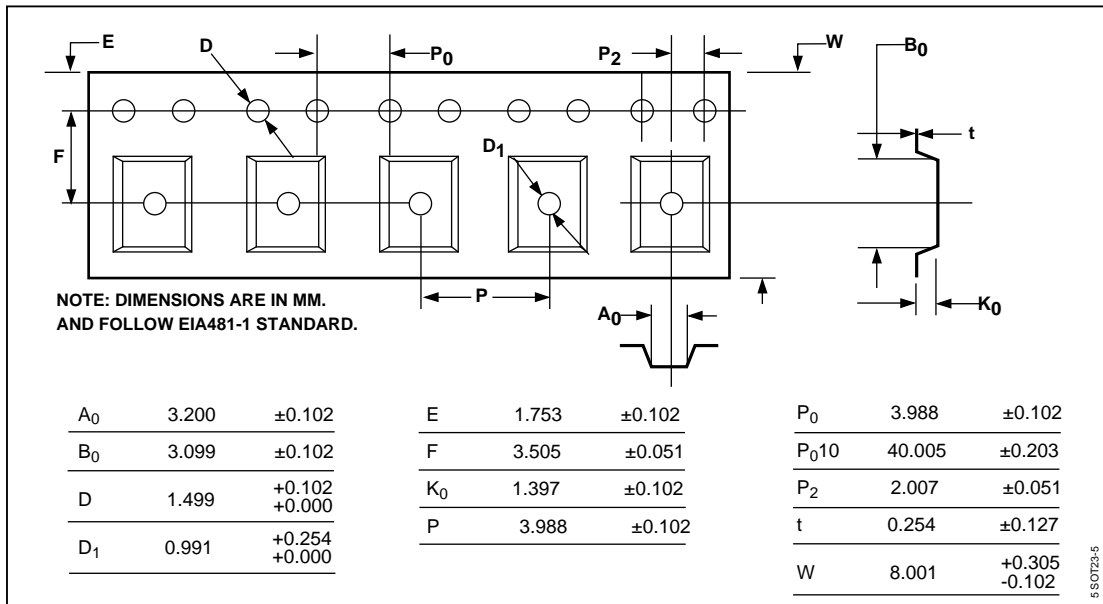

Low-Voltage, Dual-Supply, SPST,
CMOS Analog Switches

Package Information

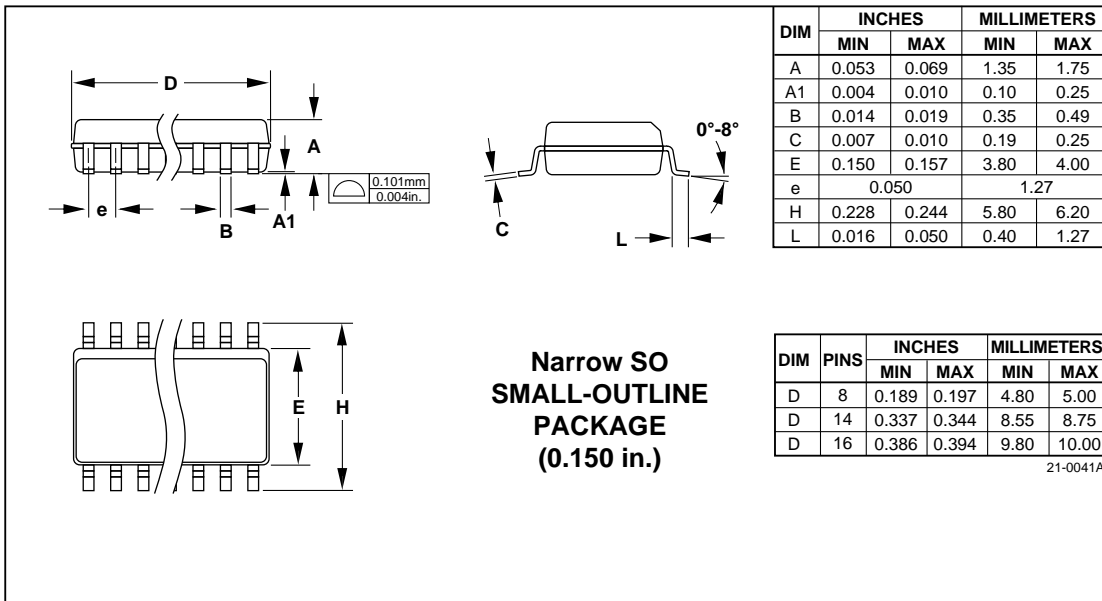
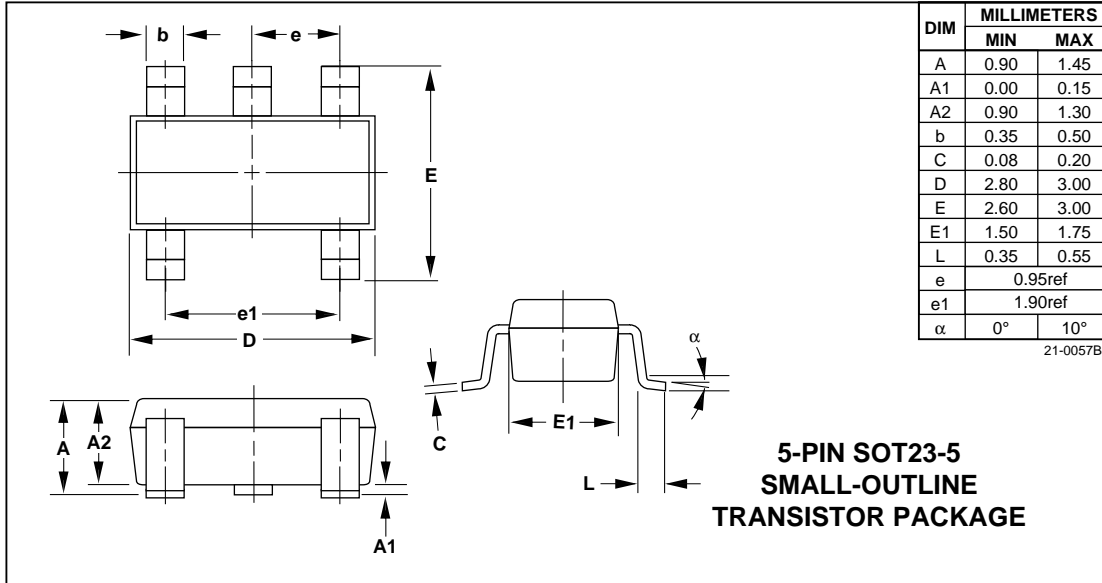

Low Voltage, Dual-Supply, SPST, CMOS Analog Switches

Package Information (continued)

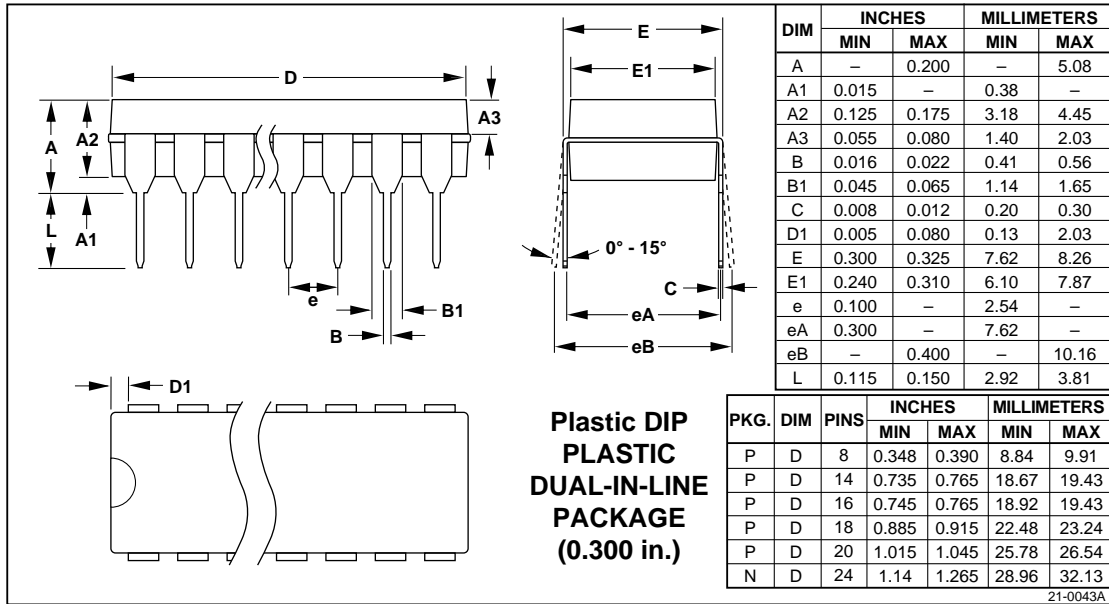

Low-Voltage, Dual-Supply, SPST, CMOS Analog Switches

Package Information (continued)

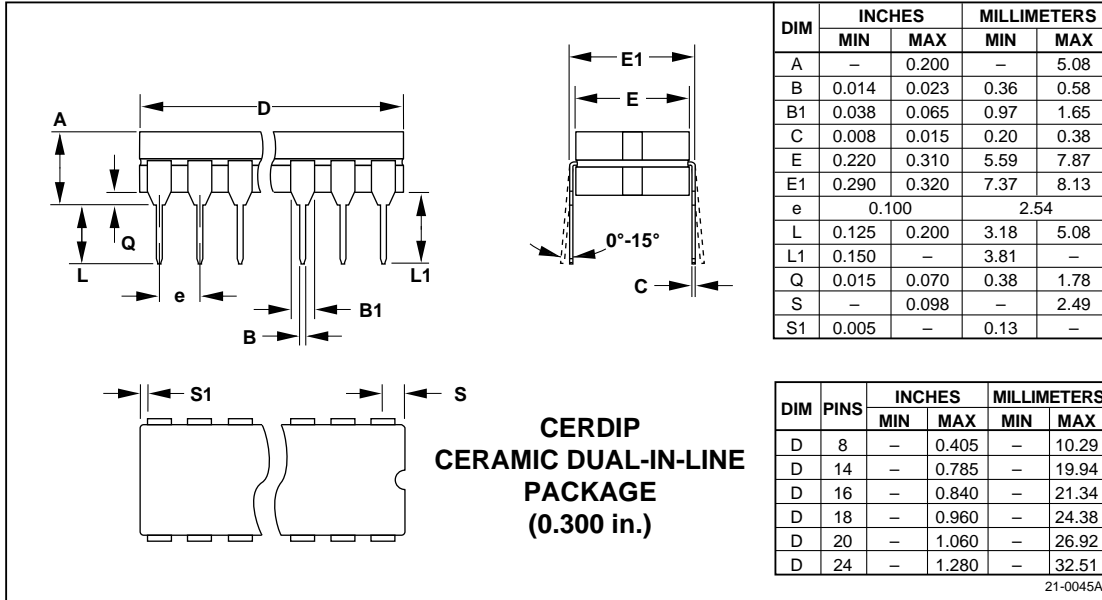

Maxim cannot assume responsibility for use of any circuitry other than circuitry entirely embodied in a Maxim product. No circuit patent licenses are implied. Maxim reserves the right to change the circuitry and specifications without notice at any time.

12 _____ Maxim Integrated Products, 120 San Gabriel Drive, Sunnyvale, CA 94086 (408) 737-7600