

General Description

The MAX40658 evaluation kit (EV kit) is a fully assembled electrical demonstration kit that provides a proven design to evaluate the MAX40658 and MAX40659 transimpedance amplifier.

Note that the MAX40658 evaluation kit provides an electrical interface to the IC that is similar, but not identical to, a photodiode.

The MAX40658 EV kit PCB comes with a MAX40658AETA+ 18.3k Ω transimpedance device installed. To evaluate the MAX40659AETA+ (36.6k Ω transimpedance), contact the factory for free samples of the pin-compatible device.

Features

- Easy +3.3V Electrical Evaluation of MAX40658
- EV Kit Designed for 50 Ω Interfaces
- -40°C to +85°C Temperature Range
- Evaluated 8-TDFN-EP MAX40658AETA+ Device
- Accommodates Easy-to-Use Components
- Proven PCB Layout
- Fully Assembled and Tested

[Ordering Information](#) appears at end of data sheet.

Quick Start

Required Equipment

- MAX40658 EV kit
- +3.6V, 100mA DC power supply
- Signal source up to 1GHz
- A minimum 500MHz to 2.5GHz oscilloscope

Procedure

The MAX40658 EV kit is fully assembled and tested. Follow the below to verify board operation:

Caution: Do not turn on the power supply or the electronic load until all the connections are complete.

- 1) Connect a +3.3V supply and ground to V1_Supply connector.
- 2) Connect a signal source to J2. Set the signal amplitude to 20mV_{P-P} (7.07mV_{RMS} or -30dBm). (Corresponding to 3.6 μ A_{P-P}). Set the frequency to 100MHz.
- 3) Apply 1 μ A to the J11 DC input using a DC current source to emulate the DC component of the input signal. A voltage source connected from J11 to GND may be used if a DC current source is not available.
- 4) Connect OUT1+ (J10) and OUT- (J7) to the 50 Ω inputs of a high-speed oscilloscope.
- 5) Verify all the shunts are in default positions as shown in [Table 1](#).
- 6) The differential signal at the oscilloscope should be approximately 43mV_{P-P} at 100MHz.

Detailed Description of Hardware

The MAX40658 accepts a DC-coupled input from a high-speed photodiode. The MAX40658 evaluation board facilitates evaluation of MAX40658 TIA without a photodiode. The MAX40658 EV kit comes from the factory with a low input current and a high input current setup.

Theory of Operation

The MAX40658 EV kit comes with an 8-TDFN EP with circuit providing photodiode emulation using a simplified electrical photodiode model. The model provides a 50Ω electrical input termination, resistors that convert the high-speed input voltage to high-speed current. A DC path is provided to model the average photodiode current.

Test Interface

The MAX40658 outputs are back-terminated with 75Ω. To facilitate interface with 50Ω equipment, the MAX40658 EV kit places external 150Ω termination resistors in parallel with each output so that the EV kit will match a 50Ω environment.

Note that the output load has a direct effect on the overall gain and output signal swing. Because of the external 150Ω resistors and the 50Ω environments, the overall gain is reduced by 33%. If matching a 50Ω environment is not critical, higher gain can be achieved by increasing the load resistance.

Current Pulse Measurements

To perform pulse measurements, the current pulses are created by providing a voltage pulse at J1 or J2 input. The input series resistance combination (R5 + R7) or

(R6 + R8), respectively, determines the amplitude of the current pulse.

For best performance, when providing the input voltage pulse at J1, remove the DC blocking capacitors C1 and C2 and replace them with a 0Ω short to DC couple the input to the MAX40658. Remove R3.

Use the following resistor combinations as shown in [Table 1](#) to create the respective current amplitude pulses.

Current Pulse Measurements

To perform pulse measurements, the current pulses are created by providing a voltage pulse at J1 or J2 input. The input series resistance combination (R5+R7) or (R6+R8) respectively determines the amplitude of the current pulse.

For best performance, when providing the input voltage pulse at J1, remove the DC blocking capacitors C1 and C2 and replace them with a 0Ω short to DC couple the input to the MAX40658. Remove R3.

Use the following resistor combinations as shown in the table below to create the respective current amplitude pulses.

Noise measurements

Remove the input resistors and shunt capacitor before attempting noise measurement. With the input resistors and shunt capacitor removed, the total capacitance at the IN-input 0.5pF.

Table 1. Different Values of Rs (R5+R7) for Different Input Current Pulse Amplitudes.

INPUT SERIES RESISTANCE R _S (Ω)	GENERATOR INPUT AMPLITUDE STEP (V)	GENERATED INPUT CURRENT STEP (MA)
2200	0.55	0.1
100	0.35	1
9.4	4.6	92

Ordering Information

PART	TYPE
MAX40658EVKIT#	EV Kit

#Denotes RoHS compliant.

MAX40658 EV Kit Bill of Materials

ITEM	REF_DES	DNI/DNP	QTY	MFG PART #	MANUFACTURER	VALUE	DESCRIPTION	COMMENTS
1	C1, C3, C5, C7, C8, C24	-	6	GRM155R61C104KA88	MURATA	0.1UF	CAPACITOR; SMT (0402); CERAMIC; 0.1UF; 16V; TOL=10%; MODEL=GRM SERIES; TG=-55 DEGC to +85 DEGC; TC=X5R	
2	C2, C6, C17, C18	-	4	C0402C101J5GAC; NMC0402NPO101J; CC0402JRNPO9BN101; GRM1555C1H101JA01; C1005C0G1H101J050	KEMET/NIC COMPONENTS CORP./ YAGEO PHICOMP/MURATA/TKD	100PF	CAPACITOR; SMT (0402); CERAMIC CHIP; 100PF; 50V; TOL=5%; TG=-55 DEGC TO +125 DEGC; TC=COG	
3	C4, C23	-	2	C0402X5R6R3-225MNP; C0402C225M9PAC; GRM155R60J225ME; JMK105BJ225MV	VENKEL/KEMET/MURATA/ TAIYO YUDEN	2.2UF	CAPACITOR; SMT; (0402); CERAMIC; 2.2uF; 6.3V; 20%; X5R; -55degC to + 85degC; 0 +/-15% degC MAX.	
4	C11, C12	-	2	C0402X7R500-222KNE; GRM155R71H222KA01	VENKEL LTD./MURATA	2200PF	CAPACITOR; SMT (0402); CERAMIC CHIP; 2200PF; 50V; TOL=10%; TG=-55 DEGC TO +125 DEGC; TC=X7R	
5	C13-C16, C19-C22, C25, C26	-	10	C0402X5R100-105KNE; GRM155R61A105KE15	VENKEL LTD./MURATA	1UF	CAPACITOR; SMT (0402); CERAMIC CHIP; 1UF; 10V; TOL=10%; MODEL=; TG=-55 DEGC TO +85 DEGC; TC=X5R	
6	J1, J2, J7-J10	-	6	32K243-40ML5	ROSENBERGER	32K243-40ML5	CONNECTOR; FEMALE; SMT; SMA JACK PCB; RIGHT ANGLE; 2PINS	
7	J3, J5, J11, J12	-	4	131-3701-266	JOHNSON COMPONENTS	131-3701-266	CONNECTOR; MALE; THROUGH HOLE; SMB JACK VERTICAL PCB MOUNT; STRAIGHT; 5PINS	
8	L1, L2	-	2	BLM15BD601SN1	MURATA	600	INDUCTOR; SMT (0402); FERRITE-BEAD; 600; TOL=+/-25%; 0.2A	
9	OUT+_U1, OUT+_U2, OUT-_U1, OUT-_U2	-	4	5012	KEYSTONE	N/A	TEST POINT; PIN DIA=0.125IN; TOTAL LENGTH=0.445IN; BOARD HOLE=0.063IN; WHITE; PHOSPHOR BRONZE WIRE SILVER PLATE FINISH;	
10	R1, R2	-	2	TNPW040249R9BE; RG1005P-49R9-B-T; ERA-2AEB49R9X	SUSUMU CO LTD./PANASONIC/ VISHAY	49.9	RESISTOR; 0402; 49.9 OHM; 0.1%; 25PPM; 0.063W; THICK FILM	
11	R3, R4	-	2	CRCW04025K10FK	VISHAY DALE	5.1K	RESISTOR; 0402; 5.1K; 1%; 100PPM; 0.0625W; THICK FILM	
12	R5, R7	-	2	RG1005P-101-B-T5; ERA-2AEB101X	SUSUMU CO LTD./PANASONIC	100	RESISTOR; 0402; 100 OHM; 0.1%; 25PPM; 0.0625W; THICK FILM	
13	R6, R8	-	2	CRCW04022K55FK	VISHAY DALE	2.55K	RESISTOR; 0402; 2.55K OHM; 1%; 100PPM; 0.0625W; THICK FILM	
14	R9, R10	-	2	ERJ-2RKF4992X	PANASONIC	49.9K	RESISTOR; 0402; 49.9K OHM; 1%; 100PPM; 0.10W; THICK FILM	
15	R11-R14	-	4	CRCW0402150RFX; 9C04021A1500FL	VISHAY DALE	150	RESISTOR; 0402; 150 OHM; 1%; 100PPM; 0.0625W; THICK FILM	
16	U1, U2	-	2	MAX40658	MAXIM	MAX40658	EVKIT PART-IC; PACKAGE OUTLINE: 21-0137	
17	V1_GND, V2_GND, V1_SUPPLY, V2_SUPPLY	-	4	9020 BUSS	WEICO WIRE	MAXIMPAD	EVK KIT PARTS; MAXIM PAD; WIRE; NATURAL; SOLID; WEICO WIRE; SOFT DRAWN BUS TYPE-S; 20AWG	
18	PCB	-	1	MAX40658	MAXIM	PCB	PCB:MAX40658	
19	C9, C10	DNP	0	C0402C109C1GAC	KEMET	1PF	CAPACITOR; SMT; 0402; CERAMIC; 1pF; 100V; 0.25pF; COG; -55degC to + 125degC;	
TOTAL			61					

MAX40658 EV Kit Schematic

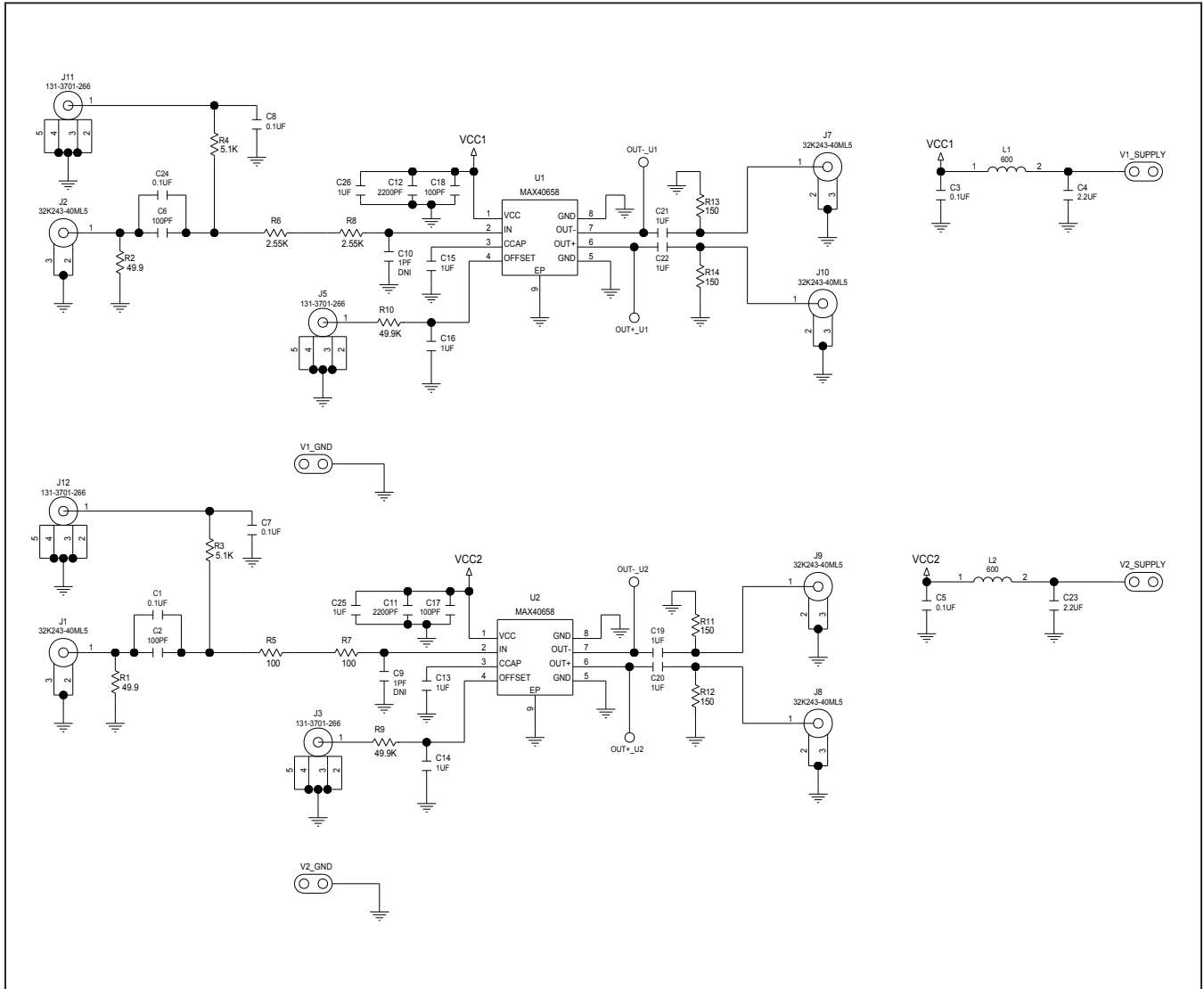

MAX40658 EV Kit PCB Layout Diagrams

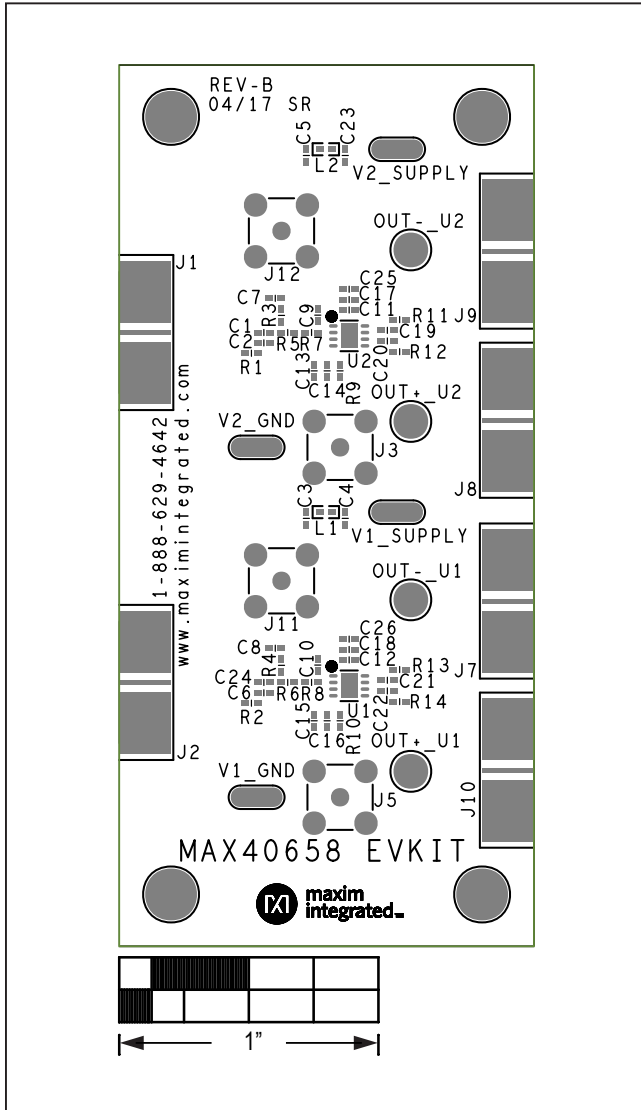

MAX40658 EV Kit—Silk Top

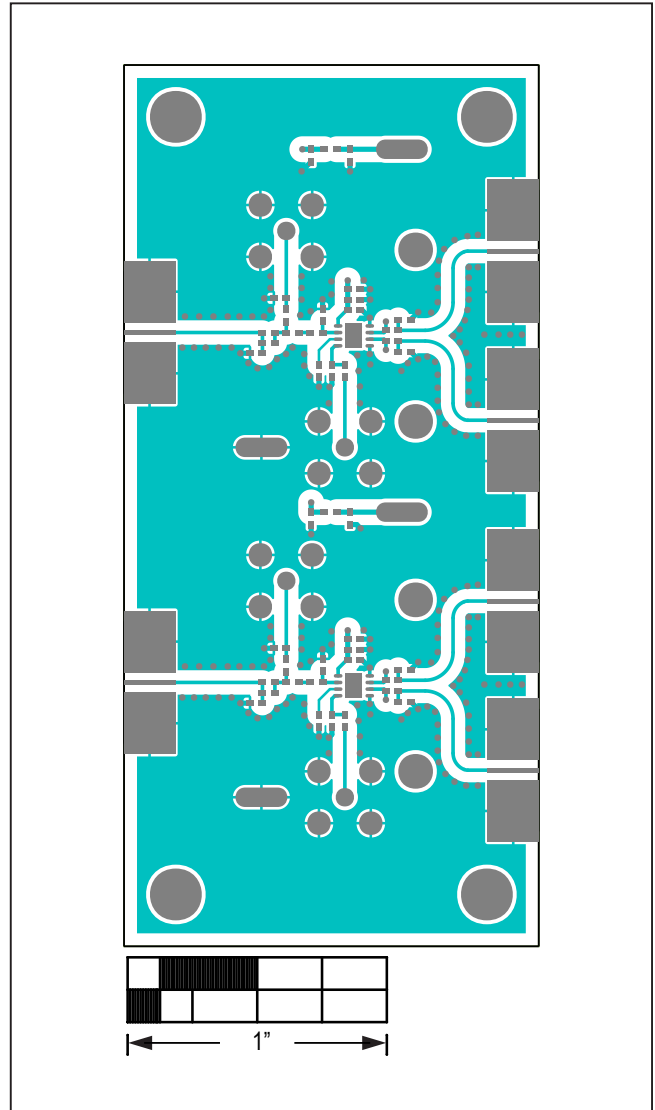

MAX40658 EV Kit—Top

MAX40658 EV Kit PCB Layout Diagrams (continued)

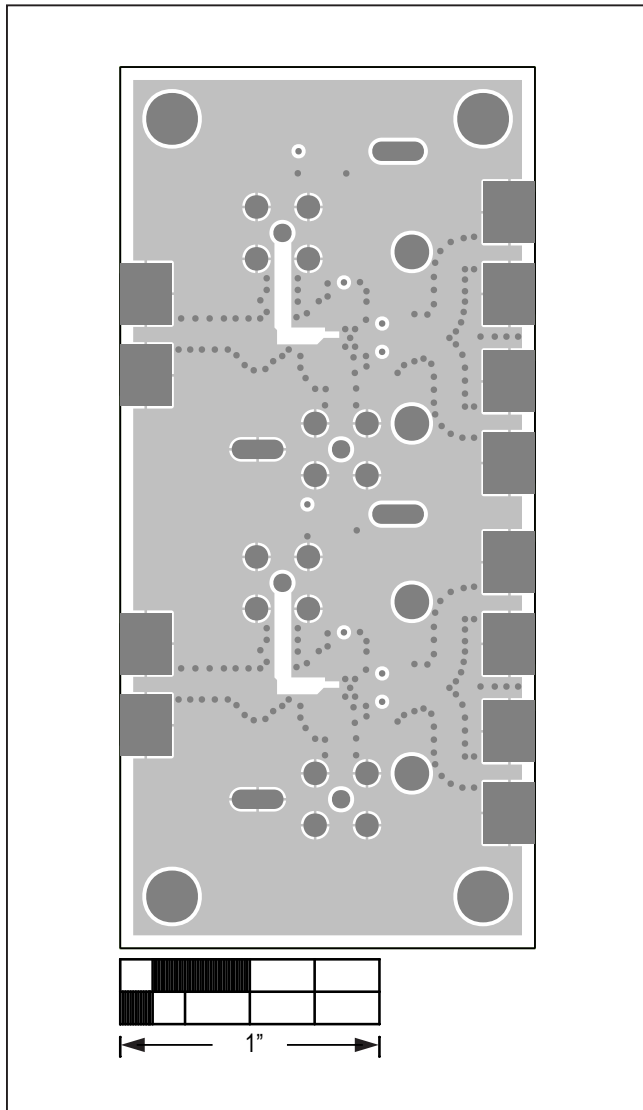

MAX40658 EV Kit—GND2

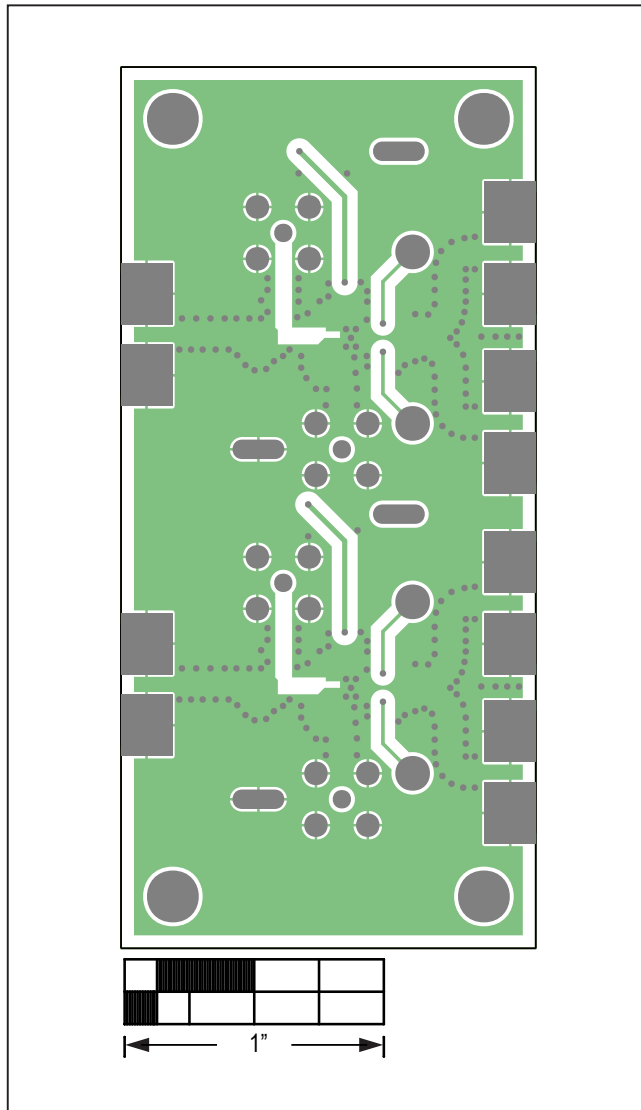

MAX40658 EV Kit—GND3

MAX40658 EV Kit PCB Layout Diagrams (continued)

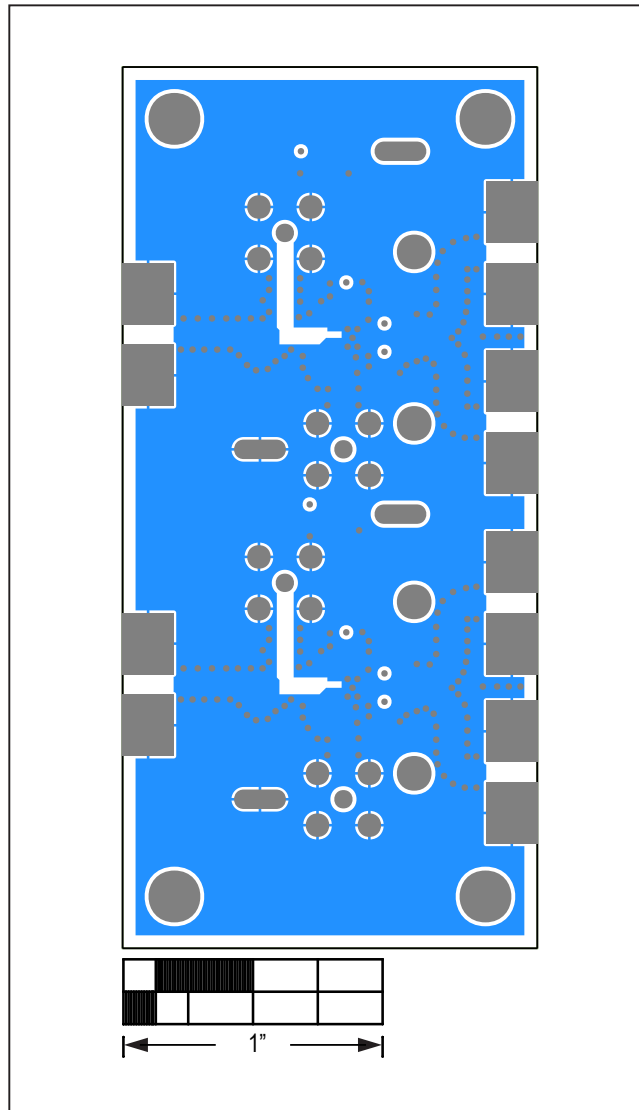

MAX40658 EV Kit—Bottom

Revision History

REVISION NUMBER	REVISION DATE	DESCRIPTION	PAGES CHANGED
0	7/17	Initial release	—

For pricing, delivery, and ordering information, please contact Maxim Direct at 1-888-629-4642, or visit Maxim Integrated's website at www.maximintegrated.com.

Maxim Integrated cannot assume responsibility for use of any circuitry other than circuitry entirely embodied in a Maxim Integrated product. No circuit patent licenses are implied. Maxim Integrated reserves the right to change the circuitry and specifications without notice at any time.