

### Description

MAX3485 is a RS-485 transceiver with 3.0V~5.5V wide power supply, bus port ESD protection capacity of over 15kV HBM, bus withstand voltage range of  $\pm 15V$ , half duplex, low power consumption, and fully meet the requirements of TIA / EIA-485 standard.

MAX3485 includes a driver and a receiver, both of which can be enabled and closed independently. When both are disabled, both the driver and the receiver output are high resistance state. MAX3485 has 1/8 load, which allows 256 MAX3485 transceivers to be connected to the same communication bus. It can realize error-free data transmission up to 10Mbps.

MAX3485 has a working voltage range of 3.0~5.5V, and has the functions of fail safe, over temperature protection, current-limiting protection, over-voltage protection, etc.

### Features

- Fail-safe Circuitry
- Low Power Consumption
- Up to 256 Transceivers can be Attached to The Bus
- Maximum Transmission Rate: 10Mbps
- ESD:  $\geq \pm 15kV$
- SOP8 Package

### Applications

- RS-485 Communications
- Level Translators
- Security Equipment
- Industrial Control Equipment
- Watt-hour meter

### Package and Pin Configuration

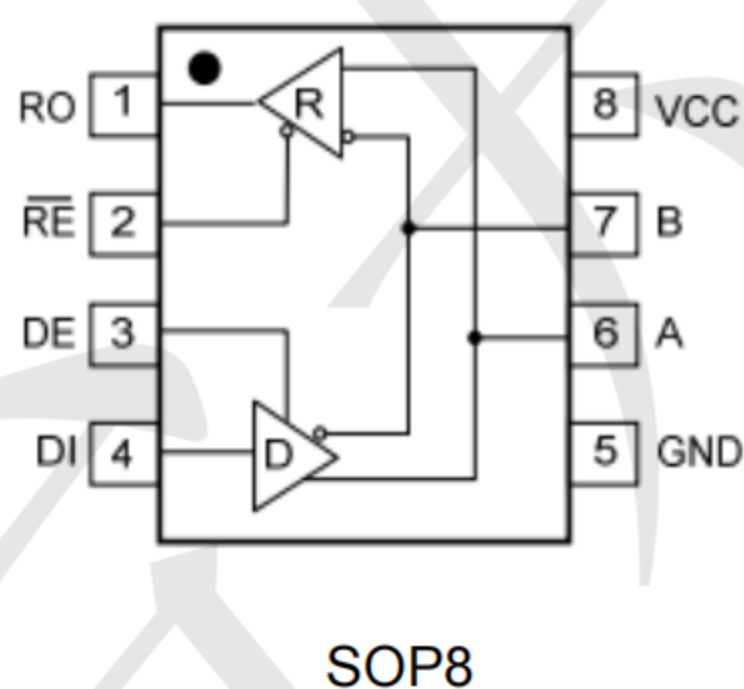

### Marking

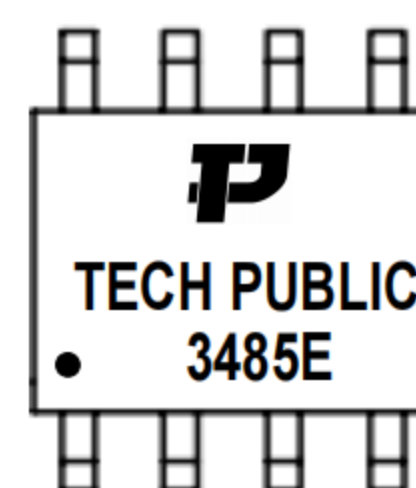

## Pin Description

PIN	SYMBOL	DESCRIPTION
1	RO	Receiver Output. When /RE is low and if $A - B \geq -10\text{mV}$ , RO will be high; if $A - B \leq -200\text{mV}$ , RO will be low.
2	/RE	Receiver Output Enable. Drive /RE low to enable RO; RO is high impedance when /RE is high. Drive /RE high and DE low to enter low-power shutdown mode.
3	DE	Driver Output Enable. Drive DE high to enable driver outputs. These outputs are high impedance when DE is low. Drive /RE high and DE low to enter low-power shutdown mode.
4	DI	Driver Input. With DE high, a low on DI forces non-inverting output low and inverting output high. Similarly, a high on DI forces non-inverting output high and inverting output low.
5	GND	Ground
6	A	non-inverting Receiver Input and non-inverting Driver Output
7	B	Inverting Receiver Input and Inverting Driver Output
8	VCC	Positive Supply

## Typical application circuit

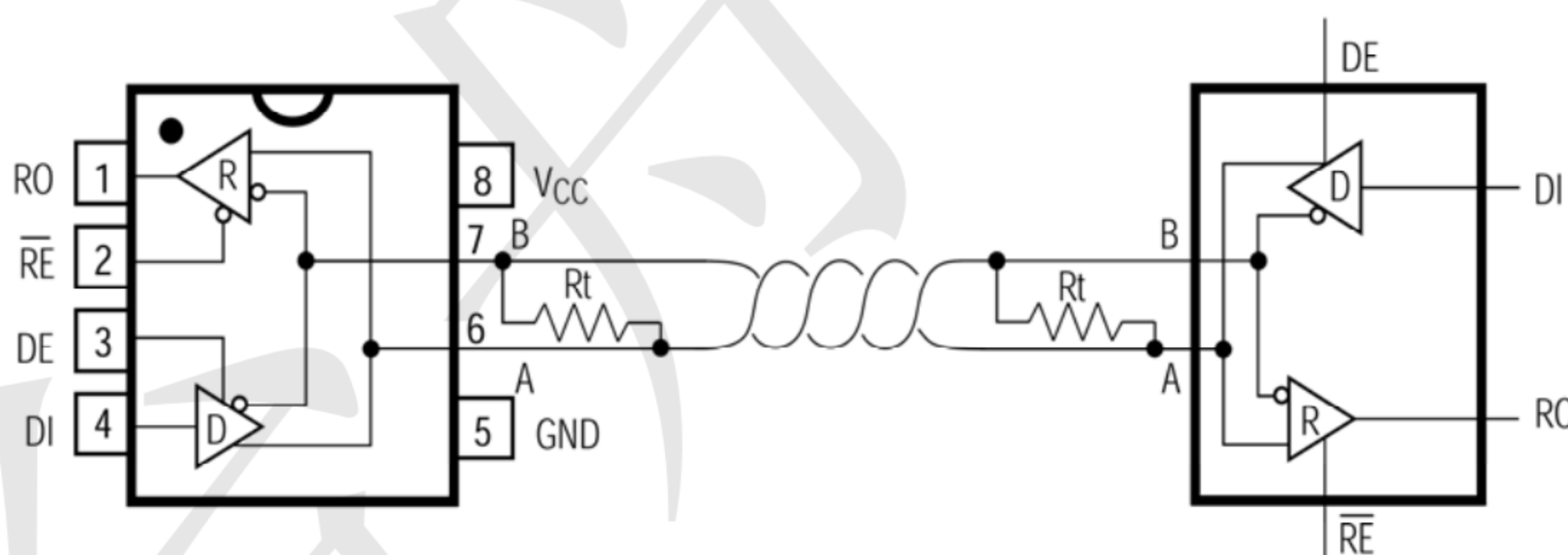

### Function Tables

#### ● TRANSMITTING

INPUTS			OUTPUTS	
/RE	DE	DI	A	B
X	1	1	1	0
X	1	0	0	1
0	0	X	High-Z	High-Z
1	0	X	Shutdown	

#### ● RECEIVING

INPUTS			OUTPUTS
/RE	DE	A-B	RO
0	X	$\geq -0.05V$	1
0	X	$\leq -0.2V$	0
0	X	Open / Shorted	1
1	1	X	High-Z
1	0	X	Shutdown

### Absolute Maximum Rating (TA=25°C)

Parameter Name	Value	Unit
Supply Voltage ( V <sub>CC</sub> )	7	V
Operating Voltage	+3~5.5	V
Control Input Voltage ( /RE, DE )	-0.3~V <sub>CC</sub> +0.3	V
Driver Input Voltage ( DI )	-0.3~V <sub>CC</sub> +0.3	V
Driver Output Voltage ( A,B )	±13	V
Receiver Input Voltage ( A,B )	±13	V
Receiver Output Voltage ( RO )	-0.3~V <sub>CC</sub> +0.3	V
Operating Temperature ( T <sub>OPR</sub> )	-40~+125	°C
Storage Temperature ( T <sub>STG</sub> )	-65~+150	°C
Operating voltage	+3~+5.5	V



DC Electrical Characteristics (VCC=5V TA=25°C)

PARAMETER	SYMBOL	CONDITIONS		MIN	TYP	MAX	UNITS
Differential Driver Output ( no load )	V <sub>OD1</sub>	R=27Ω, Figure 1		---	---	VCC	V
Differential Driver Output	V <sub>OD2</sub>			1.5	---	---	V
Change in Magnitude of Differential Output Voltage	ΔV <sub>OD</sub>			---	---	0.2	V
Driver Common-Mode Output Voltage	V <sub>OC</sub>			1.0	---	3.0	V
Change in Magnitude of Common-Mode Voltage <sup>2</sup>	ΔV <sub>OC</sub>			---	---	0.2	V
Input High Voltage	V <sub>IH</sub>	DE, DI, /RE		2.0	---	---	V
Input Low Voltage	V <sub>IL</sub>	DE, DI, /RE		---	---	0.8	V
DI Input Hysteresis	V <sub>HYS</sub>	---		---	100	---	mV
Driver Input Current ( A And B )	I <sub>IN1</sub>	V <sub>IN</sub> =12V	DE=0V, V <sub>CC</sub> =5.0V	---	---	250	μA
		V <sub>IN</sub> =-7V		-150	---	---	μA
Driver Short-Circuit Output Current <sup>3</sup>	I <sub>OSD</sub>	A and B Short-Circuit		-100	---	100	mA
Receiver Differential Threshold Voltage	V <sub>TH</sub>	-7V ≤ V <sub>CM</sub> ≤ 12V		-200	-12 5	-50	mV
Receiver Input Hysteresis	ΔV <sub>TH</sub>	---		---	40	---	mV
Receiver Output High Voltage	V <sub>OH</sub>	I <sub>O</sub> =-8mA		VCC-1	---	---	V
Receiver Output Low Voltage	V <sub>OL</sub>	I <sub>O</sub> =8mA		---	---	0.4	V
Three-State Output Current at Receiver	I <sub>OZR</sub>	V <sub>O</sub> =1V		-1	---	1	μA
Receiver Input Resistance	R <sub>IN</sub>	-7V ≤ V <sub>CM</sub> ≤ 12V		96	---	---	K Ω
Receiver Output Short-Circuit Current	I <sub>OSR</sub>	0V ≤ V <sub>RO</sub> ≤ VCC		±7	---	±10 0	mA
Supply Current	I <sub>CC</sub>	DE=V <sub>C</sub>	No Load /RE=DI=VCC/G ND	---	700	1200	μA
		DE=GN D		---	600	1200	μA
Supply Current in Shutdown Mode	I <sub>SHDN</sub>	DE=GND, /RE=VCC, DI=VCC/GND		---	---	3	μA

DC Electrical Characteristics (VCC=3V TA=25°C)

PARAMETER	SYMBOL	CONDITIONS		MIN	TYP	MAX	UNITS
Differential Driver Output ( no load )	V <sub>OD1</sub>	R=27Ω, Figure 1		---	---	VCC	V
Differential Driver Output	V <sub>OD2</sub>			0.9	---	---	V
Change in Magnitude of Differential Output Voltage	ΔV <sub>OD</sub>			---	---	0.2	V
Driver Common-Mode Output Voltage	V <sub>OC</sub>			1.0	---	3.0	V
Change in Magnitude of Common-Mode Voltage <sup>2</sup>	ΔV <sub>OC</sub>			---	---	0.2	V
Input High Voltage	V <sub>IH</sub>	DE, DI, /RE		1.5	---	---	V
Input Low Voltage	V <sub>IL</sub>	DE, DI, /RE		---	---	0.6	V
DI Input Hysteresis	V <sub>HYS</sub>	---		---	100	---	mV
Driver Input Current ( A And B )	I <sub>IN1</sub>	V <sub>IN</sub> =12V	DE=0V,	---	---	150	uA
		V <sub>IN</sub> =-7V	V <sub>CC</sub> =3V	-150	---	---	uA
Driver Short-Circuit Output Current <sup>3</sup>	I <sub>OSD</sub>	A and B Short-Circuit		-100	---	100	mA
Receiver Differential Threshold Voltage	V <sub>TH</sub>	-7V ≤ V <sub>CM</sub> ≤ 12V		-200	---	200	mV
Receiver Input Hysteresis	ΔV <sub>TH</sub>	---		---	40	---	mV
Receiver Output High Voltage	V <sub>OH</sub>	I <sub>O</sub> =-8mA		VCC-1	---	---	V
Receiver Output Low Voltage	V <sub>OL</sub>	I <sub>O</sub> =8mA		---	---	0.6	V
Three-State Output Current at Receiver	I <sub>IOZR</sub>	V <sub>O</sub> =1V		-1	---	1	μA
Receiver Input Resistance	R <sub>IN</sub>	-7V ≤ V <sub>CM</sub> ≤ 12V		96	---	---	K Ω
Receiver Output Short-Circuit Current	I <sub>IOSR</sub>	0V ≤ V <sub>RO</sub> ≤ VCC		±7	---	±10 0	mA
Supply Current	I <sub>CC</sub>	DE=VCC	No Load	---	---	1000	μA
		DE=GND	/RE=DI=VCC/GND	---	---	1000	μA
Supply Current in Shutdown Mode	I <sub>SHDN</sub>	DE=GND, /RE=VCC DI=VCC/GND		---	---	3	μA



Switching Characteristics (VCC=5V, TA=25°C)

PARAMETER	SYMBOL	CONDITIONS	MIN	TYP	MAX	UNITS
Driver Rise or Fall Time	$t_R, t_F$	Figure 3 and 5, $R_{DIFF}=54\Omega$ $C_{L1}=C_{L2}=100pF$	---	30	---	ns
Driver Input to Output	$t_{PLH}, t_{PHL}$		---	30	60	ns
Driver Output Skew [ $T_{DPLH} - T_{DPHL}$ ]	$t_{SKEW}$		---	---	20	ns
Driver Enable time	$t_{LZ}, t_{HZ}$	Figure 4 and 6, $C_L=100pF$ (Receiver enabled)	---	---	70	ns
Driver Enable time	$t_{LZ(SHDN)},$ $t_{HZ(SHDN)}$	Figure 4 and 6, $C_L=100pF$ (Receiver disabled)	---	1400	3000	ns
Driver disable time	$t_{LZ}, t_{ZL}$	Figure 4 and 6, $C_L=100pF$	---	---	70	ns
Maximum Data Rate	$F_{MAX}$	---	10	---	---	Mbps
Receiver Rise or Fall Time	$t_R, t_F$	Figure 7	---	20	---	ns
Receiver propagation delay time	$t_{PLH}, t_{PHL}$		---	90	250	ns
[ $T_{RPLH} - T_{RPHL}$ ] Differential Receiver Skew	$t_{SKD}$		---	---	30	---
Receiver enable time	$t_{ZL}, t_{ZH}$	Figure 2 and 8, $C_{RL}=15pF$ (Driver enabled)	---	30	70	ns
Receiver enable time	$t_{ZL(SHDN)},$ $t_{ZH(SHDN)}$	Figure 2 and 8, $C_{RL}=15pF$ (Driver disabled)	---	1400	3000	ns
Receiver disable time	$t_{LZ}, t_{HZ}$	Figure 2 and 8, $C_{RL}=15pF$	---	30	70	ns
Time to Shutdown	$t_{SHDN}$	---	---	200	600	ns

Switching Characteristics (VCC=3V, TA=25°C)

PARAMETER	SYMBOL	CONDITIONS	MIN	TYP	MAX	UNITS
Driver Rise or Fall Time	$t_R, t_F$	Figure 3 and 5, $R_{DIFF}=54\Omega$ $C_{L1}=C_{L2}=100pF$	---	30	---	ns
Driver Input to Output	$t_{PLH}, t_{PHL}$		---	30	60	ns
Driver Output Skew $ T_{DPLH} - T_{DPHL} $	$t_{SKEW}$		---	---	20	ns
Driver Enable time	$t_{LZ}, t_{HZ}$	Figure 4 and 6, $C_L=100pF$ (Receiver enabled)	---	---	70	ns
Driver Enable time	$t_{LZ(SHDN)},$ $t_{HZ(SHDN)}$	Figure 4 and 6, $C_L=100pF$ (Receiver disabled)	---	1600	3000	ns
Driver disable time	$t_{LZ}, t_{ZL}$	Figure 4 and 6, $C_L=100pF$	---	---	70	ns
Maximum Data Rate	$F_{MAX}$	---	10	---	---	Mbps
Receiver Rise or Fall Time	$t_R, t_F$	Figure 7	---	20	---	ns
Receiver propagation delay time	$t_{PLH}, t_{PHL}$		---	90	250	ns
$ T_{RPLH}-T_{RPHL} $ Differential Receiver Skew	$t_{SKD}$		---	30	---	ns
Receiver enable time	$t_{ZL}, t_{ZH}$	Figure 2 and 8, $C_{RL}=15pF$ (Driver enabled)	---	25	70	ns
Receiver enable time	$t_{ZL(SHDN)},$ $t_{ZH(SHDN)}$	Figure 2 and 8, $C_{RL}=15pF$ (Driver disabled)	---	1600	3000	ns
Receiver disable time	$t_{LZ}, t_{HZ}$	Figure 2 and 8, $C_{RL}=15pF$	---	30	70	ns
Time to Shutdown	$t_{SHDN}$	---	---	230	800	ns



Test Circuit

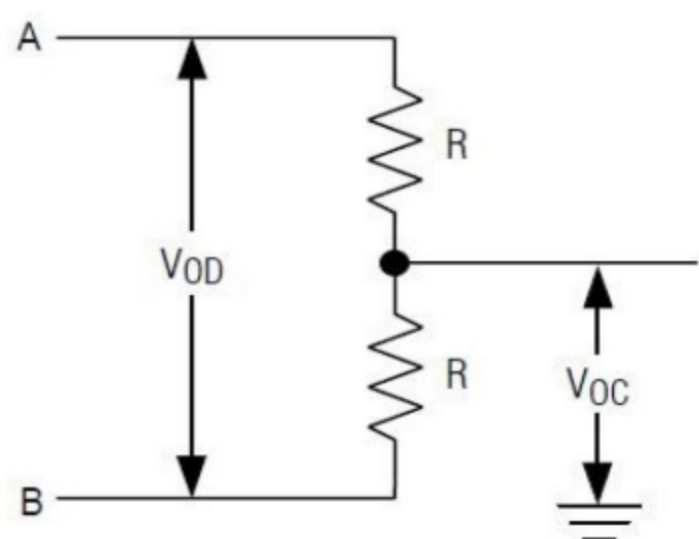

Figure 1. Driver DC Test Load

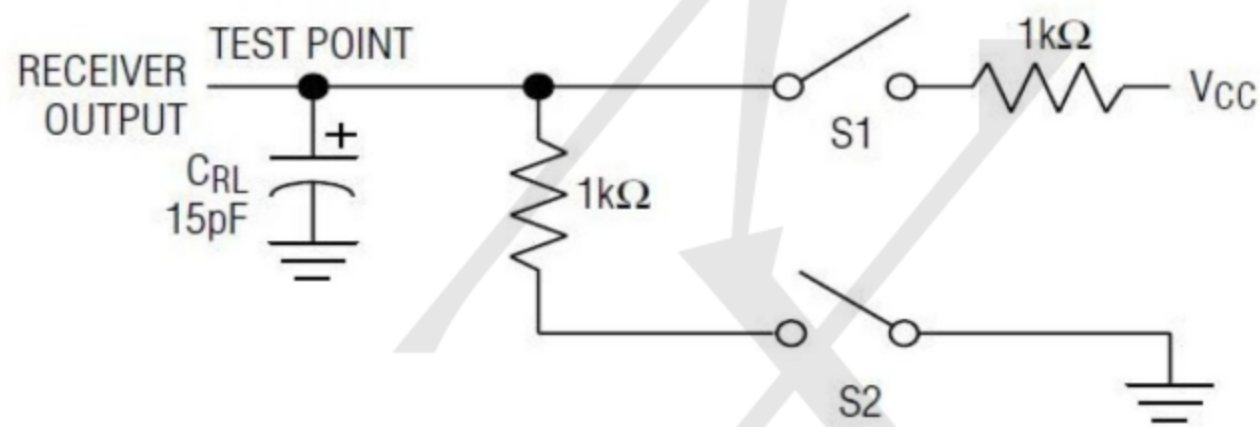

Figure 2. Receiver Enable/Disable Timing Test Load

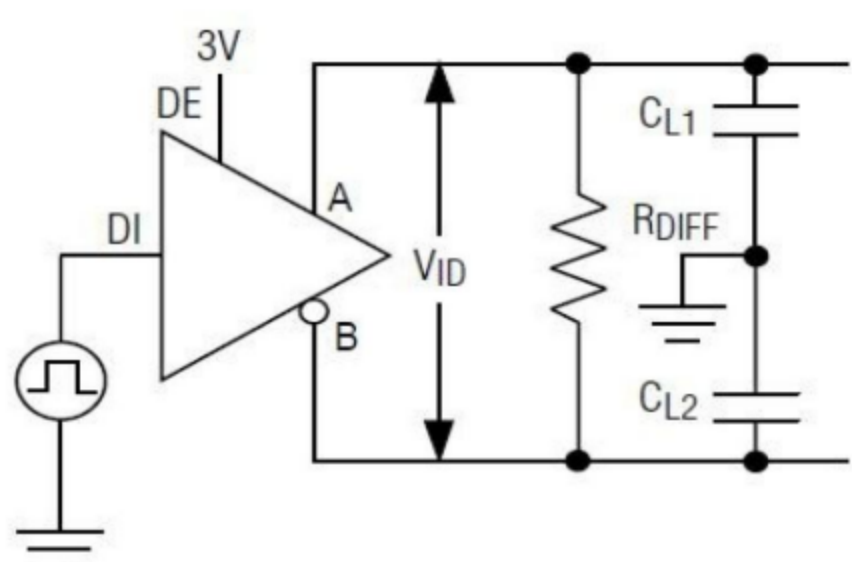

Figure 3. Driver Timing Test Circuit

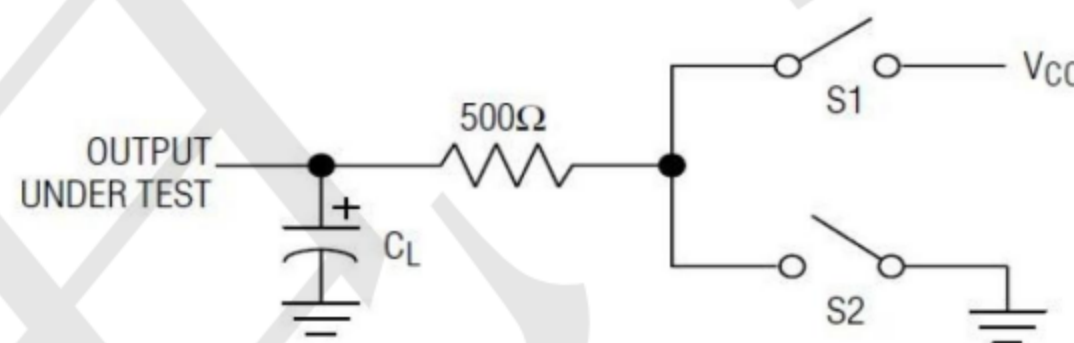

Figure 4. Driver Enable/Disable Timing Test Load

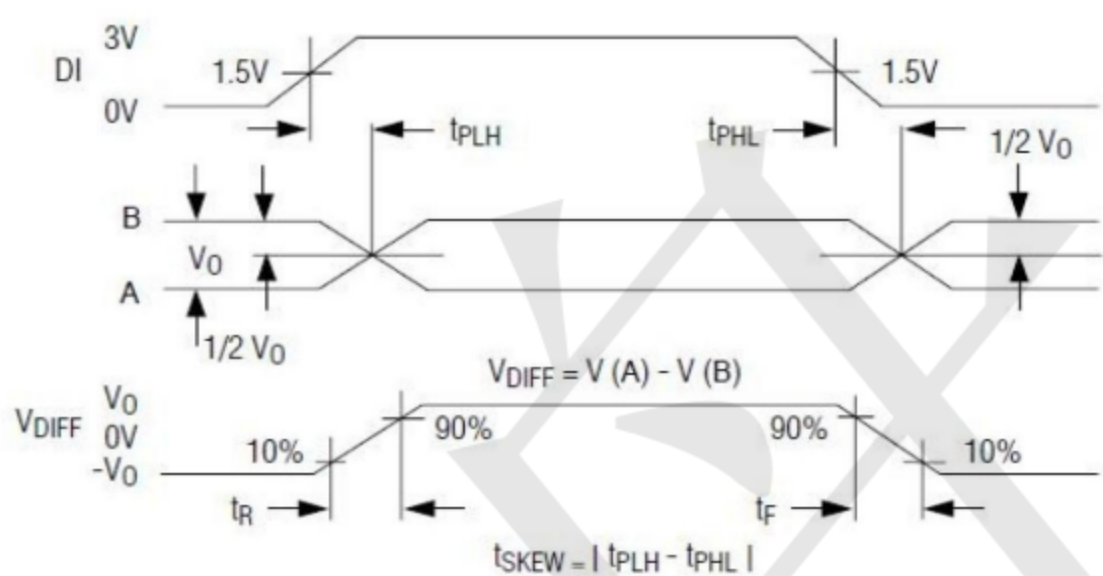

Figure 5. Driver Propagation Delays

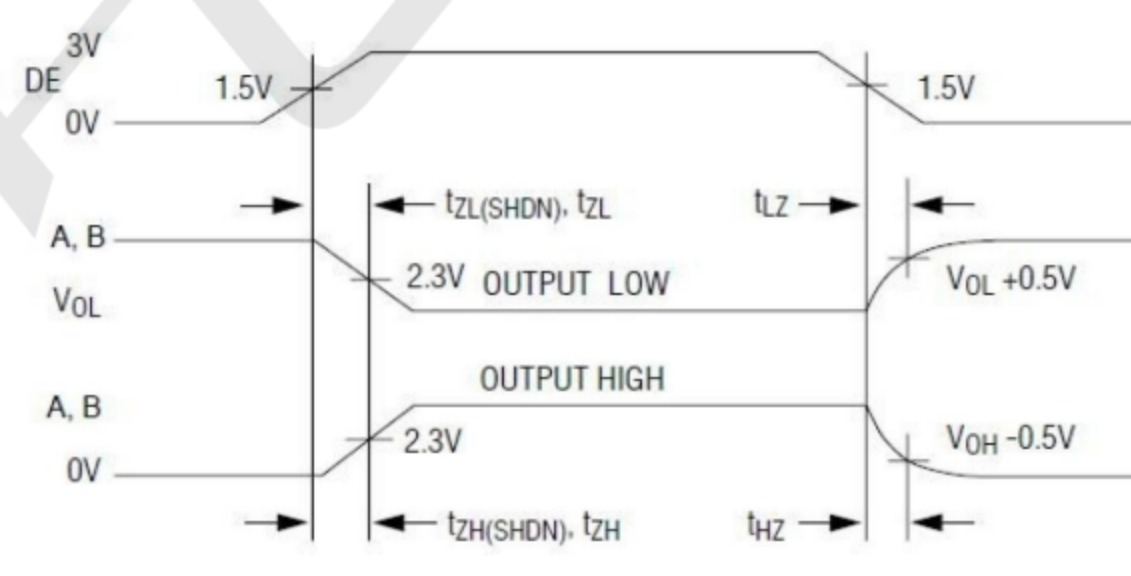

Figure 6. Driver Enable and Disable Times

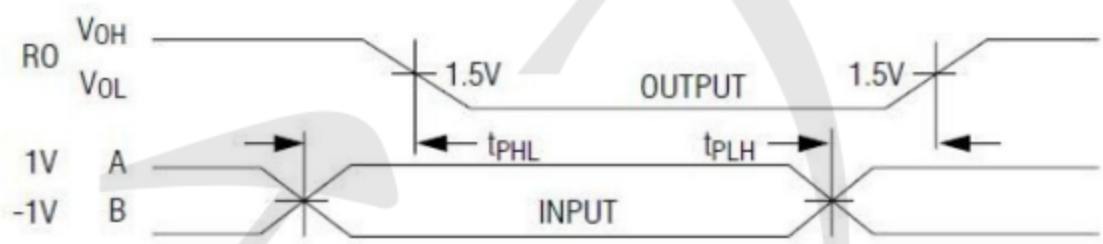

Figure 7. Receiver Propagation Delays

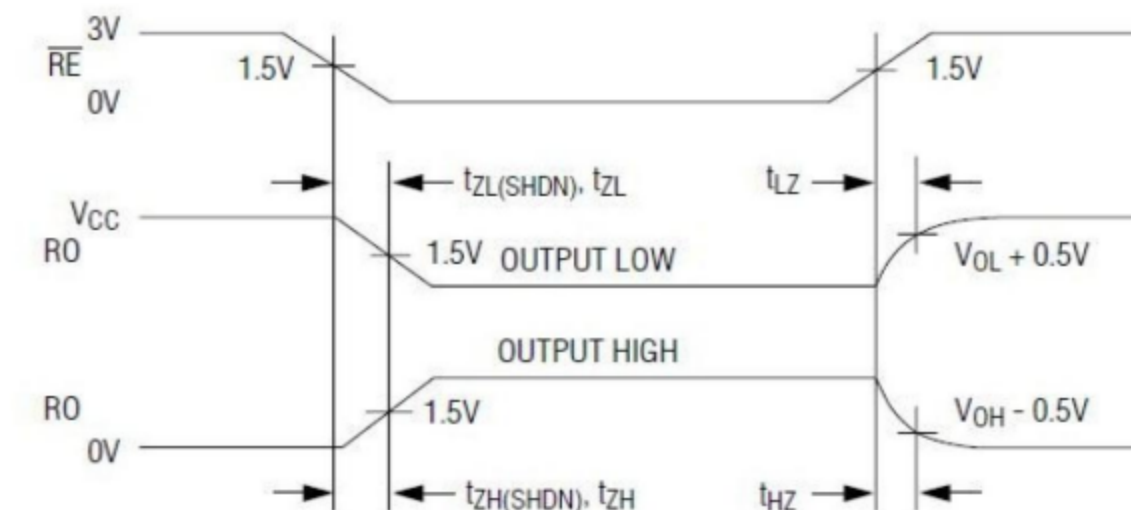
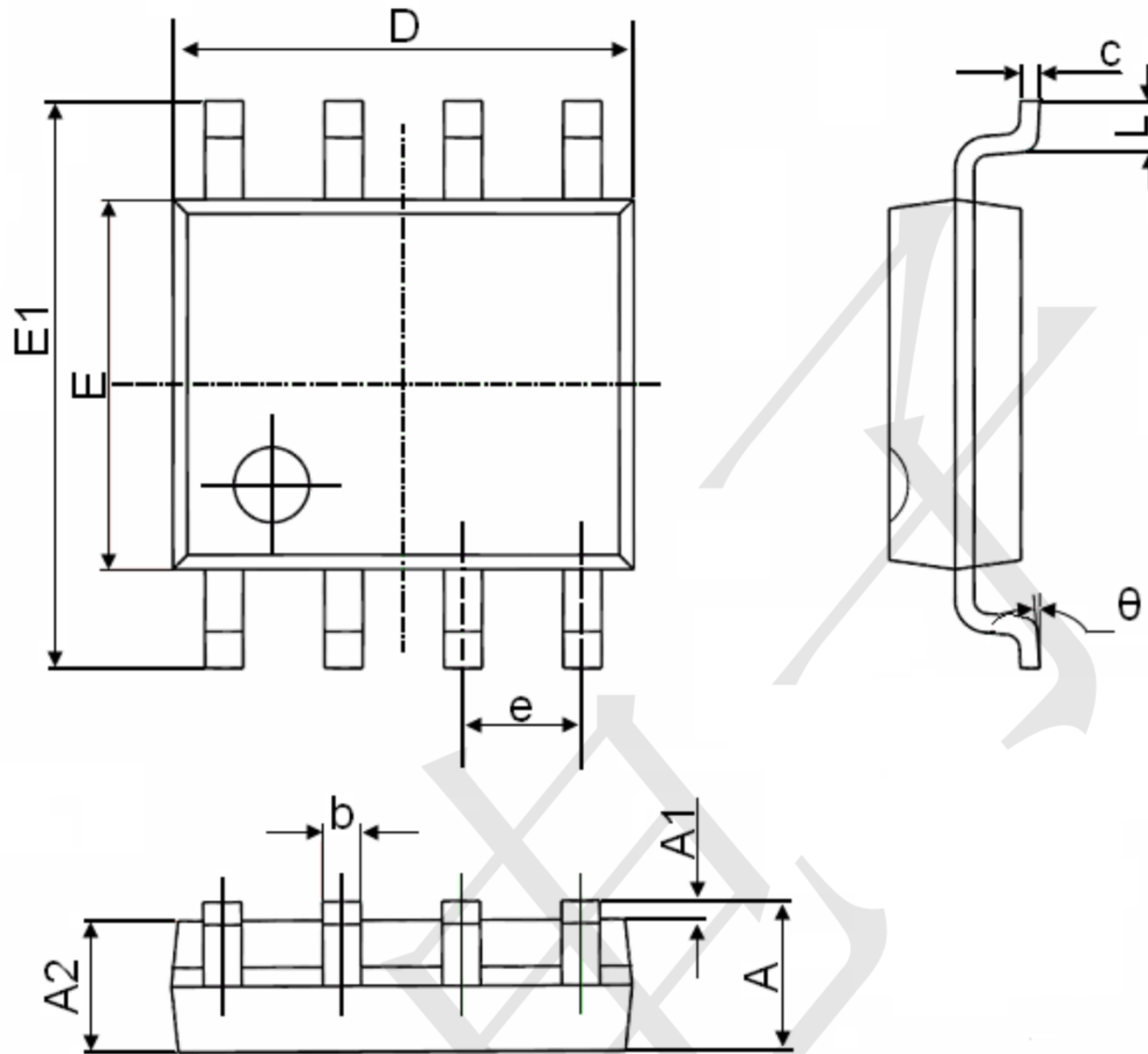

Figure 8. Receiver Enable and Disable Times



SOP-8 Package information



Symbol	Dimensions In Millimeters		Dimensions In Inches	
	Min.	Max.	Min.	Max.
A	1.350	1.750	0.053	0.069
A1	0.100	0.250	0.004	0.010
A2	1.350	1.550	0.053	0.061
b	0.330	0.510	0.013	0.020
c	0.170	0.250	0.006	0.010
D	4.700	5.100	0.185	0.200
E	3.800	4.000	0.150	0.157
E1	5.800	6.200	0.228	0.244
e	1.270(BSC)		0.050(BSC)	
L	0.400	1.270	0.016	0.050
θ	0°	8°	0°	8°