

MAX3483AE/MAX3485AE/ MAX3488AE/MAX3490AE/ MAX3491AE

**+3.3V-Powered, $\pm 20\text{kV}$ ESD-Protected,
20Mbps and Slew-Rate-Limited
RS-485/RS-422 Transceivers**

General Description

Devices in the MAX3483AE family (MAX3483AE/MAX3485AE/MAX3488AE/MAX3490AE/MAX3491AE) are $\pm 20\text{kV}$ ESD-protected RS-485/422 transceivers, optimized for extended cable runs in noisy environments. All devices operate from a single 3.3V supply.

The MAX3483AE and MAX3485AE are half-duplex transceivers. The MAX3488AE, MAX3490AE, and MAX3491AE are full-duplex transceivers. The MAX3483AE/85AE have a 1-unit load receiver input impedance, allowing up to 32 transceivers on the bus. The MAX3488AE/90AE/91AE have a 1/4-unit load receiver input impedance, allowing up to 128 transceivers on the bus. Each transceiver includes a fail-safe receiver, ensuring that the receiver output (RO) is high when inputs are shorted, open, or connected to a three-state bus.

All devices feature enhanced electrostatic discharge (ESD) protection. All transmitter outputs and receiver inputs are protected to $\pm 20\text{kV}$ HBM ESD, $\pm 15\text{kV}$ Air-Gap ESD and $\pm 8\text{kV}$ Contact ESD in accordance to IEC 61000-4-2.

The MAX3483AE, MAX3485AE, MAX3488AE, and MAX3490AE are available in industry standard 8-pin SO package, while the MAX3491AE is available in a 14-pin SO package.

Benefits and Features

- Integrated Protection Increases Robustness
 - High ESD Protection
 - $\pm 20\text{kV}$ HBM ESD per JEDEC JS-001-2012
 - $\pm 15\text{kV}$ Air Gap per IEC 61000-4-2
 - $\pm 8\text{kV}$ Contact ESD per IEC 61000-4-2
 - Short-Circuit Protected Outputs
 - True Fail-Safe Receiver Prevents False Transition on Receiver Input Short or Open Events
 - Hot-Swap Capability Eliminates False Transitions During Power-Up or Hot Insertion
- High-Speed Data Rates up to 20Mbps
- Up to -40°C to $+125^\circ\text{C}$ Operating Temperature
- Allows Up to 128 Transceivers on the Bus

Applications

- Industrial-Control Local Area Networks
- Transceivers for EMI-Sensitive Applications
- Telecommunications

Ordering Information appears at end of data sheet.

Functional Diagram

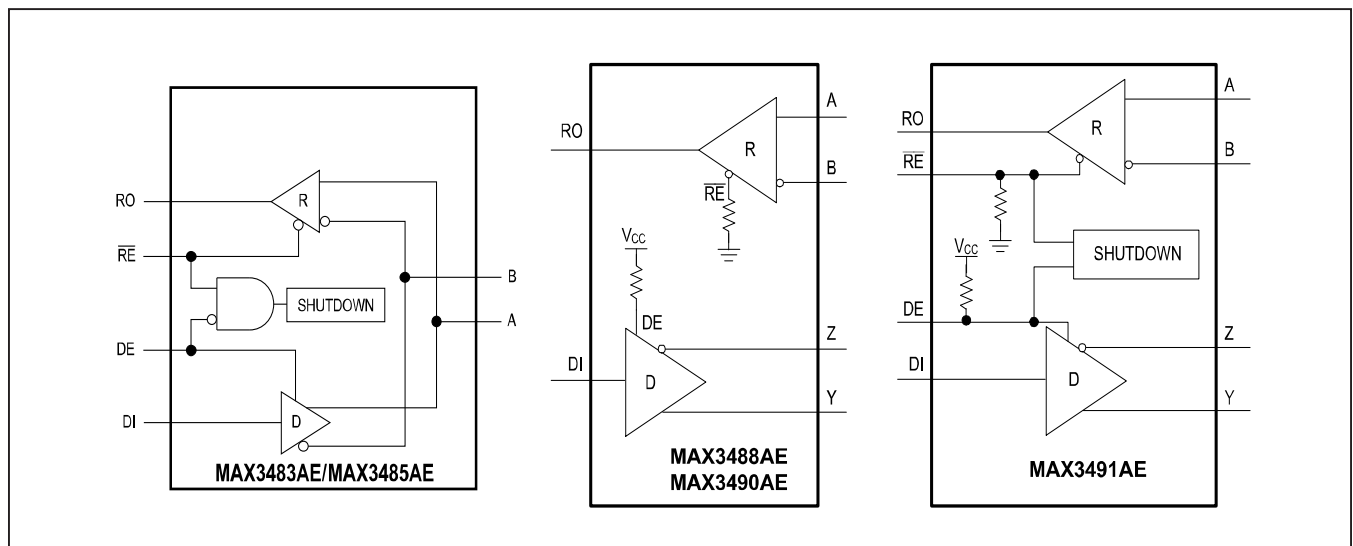

MAX3483AE/MAX3485AE/
MAX3488AE/MAX3490AE/
MAX3491AE

+3.3V-Powered, ±20kV ESD-Protected,
20Mbps and Slew-Rate-Limited
RS-485/RS-422 Transceivers

Absolute Maximum Ratings

(Voltages referenced to GND.)

V _{CC}	-0.3V to +4.0V	Junction Temperature	+150°C
RO	-0.3V to (V _{CC} + 0.3V)	Storage Temperature Range	-65°C to +150°C
RE, DE, DI	-0.3V to +4.0V	Continuous Power Dissipation (T _A = +70°C)	
A, B, Y, Z	-9.0V to +13.0V	8 SO (derate at 7.6mW/°C above +70°C)	606mW
Short-Circuit Duration (RO, A, B, Y, Z) to GND	Continuous	14 SO (derate at 11.9mW/°C above +70°C)	952mW
Operating Temperature Range		Lead Temperature (soldering, 10s)	+300°C
MAX3483AE/85AE/88AE/90AE/91AE	-40°C to +125°C	Soldering Temperature (reflow)	+260°C
MAX3488AE/90AE	-40°C to +105°C		

Stresses beyond those listed under "Absolute Maximum Ratings" may cause permanent damage to the device. These are stress ratings only, and functional operation of the device at these or any other conditions beyond those indicated in the operational sections of the specifications is not implied. Exposure to absolute maximum rating conditions for extended periods may affect device reliability.

Package Thermal Characteristics (Note 1)

Junction-to-Case Thermal Resistance (θ _{JC})		Junction-to-Ambient Thermal Resistance (θ _{JA})	
8-pin SO	38°C/W	8-pin SO	132°C/W
14-pin SO	34°C/W	14-pin SO	84°C/W

Note 1: Package thermal resistances were obtained using the method described in JEDEC specification JESD51-7, using a four-layer board. For detailed information on package thermal considerations, refer to www.maximintegrated.com/thermal-tutorial.

Electrical Characteristics

(V_{CC} = +3.0V to +3.6V, T_A = T_{MIN} to T_{MAX}, unless otherwise specified. Typical values are at V_{CC} = +3.3V and T_A = +25°C.) (Notes 2, 3)

PARAMETER	SYMBOL	CONDITIONS	MIN	TYP	MAX	UNITS
POWER SUPPLY						
Supply Voltage	V _{CC}		3.0		3.6	V
Supply Current	I _{CC}	DE = V _{CC} , RE = GND, no load		1.9	4	mA
		DE = 0, RE = 0, no load, DI = 0 or V _{CC}	1.2		4.0	
Shutdown Supply Current	I _{SHDN}	DE = GND, RE = V _{CC} , MAX3483AE/85AE/91AE			10	µA
DRIVER						
Differential Driver Output	V _{OD}	V _{CC} = 3V, R _L = 100Ω, Figure 1	2.0			V
		V _{CC} = 3V, R _L = 54Ω, Figure 1	1.5			
Change in Magnitude of Differential Output Voltage	ΔV _{OD}	R _L = 54Ω or 100Ω, Figure 1 (Note 4)	-0.2		+0.2	V
Driver Common-Mode Output Voltage	V _{OC}	R _L = 54Ω or 100Ω, Figure 1		V _{CC} /2	3	V
Change in Magnitude of Common-Mode Voltage	ΔV _{OC}	R _L = 54Ω or 100Ω, Figure 1 (Note 4)	-0.2		+0.2	V
Single-Ended Driver Output High	V _{OH}	A or B output, I _{A or B} = -20mA	2.2			V
Single-Ended Driver Output Low	V _{OL}	A or B output, I _{A or B} = 20mA			0.8	V
Driver Short-Circuit Output Current	I _{OSD}	V _{OUT} = -7V	-250			mA
		V _{OUT} = +12V			250	

MAX3483AE/MAX3485AE/
MAX3488AE/MAX3490AE/
MAX3491AE

+3.3V-Powered, ±20kV ESD-Protected,
20Mbps and Slew-Rate-Limited
RS-485/RS-422 Transceivers

Electrical Characteristics (continued)

($V_{CC} = +3.0V$ to $+3.6V$, $T_A = T_{MIN}$ to T_{MAX} , unless otherwise specified. Typical values are at $V_{CC} = +3.3V$ and $T_A = +25^{\circ}C$.) (Notes 2, 3)

PARAMETER	SYMBOL	CONDITIONS	MIN	TYP	MAX	UNITS
RECEIVER						
Input Current	$I_{A, B}$	DE = GND, $V_{CC} = GND$ or +3.6V	$V_{IN} = +12V$	430	1000	μA
			$V_{IN} = -7V$	-450	-300	
Differential Input Capacitance	$C_{A, B}$	Between A and B, DE = GND, $f = 4MHz$		12		pF
Receiver Differential Threshold Voltage	V_{TH}	$-7V \leq V_{CM} \leq +12V$	-200	-105	-10	mV
Receiver Input Hysteresis	ΔV_{TH}	$V_{CM} = 0V$		10		mV
Receiver Input Resistance	R_{IN}	$-7V \leq V_{CM} \leq +12V$	MAX3483AE/85AE	12		k Ω
			MAX3488AE/90AE/91AE	48		
LOGIC INTERFACE (DI, DE, \overline{RE}, RO)						
Input Voltage High	V_{IH}	DE, DI, \overline{RE}	2.0			V
Input Voltage Low	V_{IL}	DE, DI, \overline{RE}			0.8	V
Input Hysteresis	V_{HYS}	DE, DI, \overline{RE}		50		mV
Input Current	I_{IN}	DE, DI, \overline{RE}			±2	μA
Input Impedance on First Transition		DE, \overline{RE}	1		10	k Ω
RO Output Voltage High	V_{OHRO}	$\overline{RE} = GND$, $I_{RO} = -2mA$, ($V_A - V_B$) > 200mV	$V_{CC} - 1.5$			V
RO Output Voltage Low	V_{OLRO}	$\overline{RE} = GND$, $I_{RO} = 2mA$, ($V_A - V_B$) < -200mV			0.4	V
Receiver Three-State Output Current	I_{OZR}	$\overline{RE} = V_{CC}$, $0 \leq V_{RO} \leq V_{CC}$			±1	μA
\overline{RE} Pulldown and DE Pullup Resistance	R_{IN}			1		M Ω
Receiver Output Short-Circuit Current	I_{OSR}	$0 \leq V_{RO} \leq V_{CC}$			±110	mA
PROTECTION						
Thermal Shutdown Threshold	T_{SHDN}	Temperature rising		+160		$^{\circ}C$
Thermal Shutdown Hysteresis				15		$^{\circ}C$
ESD Protection on A, B, Z, and Y Pins		IEC 61000-4-2 Air Gap Discharge to GND		±15		kV
		IEC 61000-4-2 Contact Discharge to GND		±8		
		Human Body Model to GND		±20		
ESD Protection, All Other Pins		Human Body Model		±2		kV

MAX3483AE/MAX3485AE/
MAX3488AE/MAX3490AE/
MAX3491AE

+3.3V-Powered, ±20kV ESD-Protected,
20Mbps and Slew-Rate-Limited
RS-485/RS-422 Transceivers

Switching Characteristics MAX3485AE/MAX3490AE/MAX3491AE

($V_{CC} = +3V$ to $+3.6V$, $T_A = T_{MIN}$ to T_{MAX} , unless otherwise specified. Typical values are at $V_{CC} = +3.3V$ and $T_A = +25^\circ C$.) (Notes 2, 3, 5)

PARAMETER	SYMBOL	CONDITIONS	MIN	TYP	MAX	UNITS
DRIVER						
Driver Propagation Delay	t_{DPLH}	$R_L = 54\Omega$, $C_L = 50pF$, Figures 2 and 3			30	ns
	t_{DPHL}				30	
Driver Differential Output Rise or Fall Time	t_{HL} , t_{LH}	$R_L = 54\Omega$, $C_L = 50pF$, Figures 2 and 3			7	ns
Differential Driver Output Skew $ t_{DPLH} - t_{DPHL} $	t_{DSKEW}	$R_L = 54\Omega$, $C_L = 50pF$, Figures 2 and 3 (Note 6)			3	ns
Maximum Data Rate	DR_{MAX}		20			Mbps
Driver Enable to Output High	t_{DZH}	$R_L = 110\Omega$, $C_L = 50pF$, MAX3485AE, MAX3491AE Figures 4 and 5 (Note 7)			40	ns
Driver Enable to Output Low	t_{DZL}	$R_L = 110\Omega$, $C_L = 50pF$, MAX3485AE, MAX3491AE Figures 4 and 5 (Note 7)			40	ns
Driver Disable Time from Low	t_{DLZ}	$R_L = 110\Omega$, $C_L = 50pF$, MAX3485AE, MAX3491AE Figures 4 and 5			40	ns
Driver Disable Time from High	t_{DHZ}	$R_L = 110\Omega$, $C_L = 50pF$, MAX3485AE, MAX3491AE Figures 4 and 5			40	ns
Driver Enable from Shutdown to Output High	$t_{DLZ}(SHDN)$	$R_L = 110\Omega$, $C_L = 15pF$, MAX3485AE, Figures 4 and 5 (Note 7)			6	μs
					100	μs
Driver Enable from Shutdown to Output Low	$t_{DHZ}(SHDN)$	$R_L = 110\Omega$, $C_L = 15pF$, MAX3485AE Figures 4 and 5 (Note 7)			6	μs
Time to Shutdown	t_{SHDN}	(Note 8)	50			800 ns
RECEIVER						
Receiver Propagation Delay	t_{RPLH}	$C_L = 15pF$, Figures 6 and 7			35	ns
	t_{RPHL}				35	
Receiver Output Skew	t_{RSKEW}	$C_L = 15pF$, Figures 6 and 7 (Note 6)			2	ns
Maximum Data Rate	DR_{MAX}		20			Mbps
Receiver Enable to Output High	t_{RZH}	$R_L = 1k\Omega$, $C_L = 15pF$, MAX3485AE, MAX3491AE, Figure 8 (Note 7)			40	ns
Receiver Enable to Output Low	t_{RZL}	$R_L = 1k\Omega$, $C_L = 15pF$, MAX3485AE, MAX3491AE, Figure 8 (Note 7)			40	ns
Receiver Disable Time from Low	t_{RLZ}	$R_L = 1k\Omega$, $C_L = 15pF$, MAX3485AE, MAX3491AE, Figure 8			40	ns

MAX3483AE/MAX3485AE/
MAX3488AE/MAX3490AE/
MAX3491AE

+3.3V-Powered, ±20kV ESD-Protected,
20Mbps and Slew-Rate-Limited
RS-485/RS-422 Transceivers

Switching Characteristics MAX3485AE/MAX3490AE/MAX3491AE (continued)

($V_{CC} = +3V$ to $+3.6V$, $T_A = T_{MIN}$ to T_{MAX} , unless otherwise specified. Typical values are at $V_{CC} = +3.3V$ and $T_A = +25^\circ C$.) (Notes 2, 3, 5)

PARAMETER	SYMBOL	CONDITIONS	MIN	TYP	MAX	UNITS
Receiver Disable Time from High	t_{RHZ}	$R_L = 1k\Omega$, $C_L = 15pF$, MAX3485AE, MAX3491AE, Figure 8			40	ns
Receiver Enable from Shutdown to Output High	$t_{RLZ}(SHDN)$	$R_L = 1k\Omega$, $C_L = 15pF$, MAX3485AE, Figure 8 (Note 7)			6	μs
		$R_L = 1k\Omega$, $C_L = 15pF$, MAX3491AE, Figure 8			100	μs
Receiver Enable from Shutdown to Output Low	$t_{RHZ}(SHDN)$	$R_L = 1k\Omega$, $C_L = 15pF$, MAX3485AE, Figure 8 (Note 7)			6	μs
		$R_L = 1k\Omega$, $C_L = 15pF$, MAX3491AE, Figure 8			100	μs
Time to Shutdown	t_{SHDN}	(Note 8)	50		800	ns

Switching Characteristics (MAX3483AE/MAX3488AE)

($V_{CC} = +3V$ to $+3.6V$, $T_A = T_{MIN}$ to T_{MAX} , unless otherwise specified. Typical values are at $V_{CC} = +3.3V$ and $T_A = +25^\circ C$.) (Notes 2, 3, 5)

PARAMETER	SYMBOL	CONDITIONS	MIN	TYP	MAX	UNITS
DRIVER						
Driver Propagation Delay	t_{DPLH}	$R_L = 54\Omega$, $C_L = 50pF$, Figures 2 and 3			1000	ns
	t_{DPHL}				1000	
Driver Differential Output Rise or Fall Time	t_{HL} , t_{LH}	$R_L = 54\Omega$, $C_L = 50pF$, Figures 2 and 3	200		900	ns
Differential Driver Output Skew $ t_{DPLH} - t_{DPHL} $	t_{DSKEW}	$R_L = 54\Omega$, $C_L = 50pF$, Figures 2 and 3			140	ns
Maximum Data Rate	DR_{MAX}		250			kbps
Driver Enable to Output High	t_{DZH}	$R_L = 110\Omega$, $C_L = 50pF$, MAX3483AE Figures 4 and 5 (Note 6)			2500	ns
Driver Enable to Output Low	t_{DZL}	$R_L = 110\Omega$, $C_L = 50pF$, MAX3483AE Figures 4 and 5 (Note 6)			2500	ns
Driver Disable Time from Low	t_{DLZ}	$R_L = 110\Omega$, $C_L = 50pF$, MAX3483AE Figures 4 and 5			100	ns
Driver Disable Time from High	t_{DHZ}	$R_L = 110\Omega$, $C_L = 50pF$, MAX3483AE Figures 4 and 5			100	ns
Driver Enable from Shutdown to Output High	$t_{DLZ}(SHDN)$	$R_L = 110\Omega$, $C_L = 15pF$, MAX3483AE Figures 4 and 5 (Note 6)			10	μs

MAX3483AE/MAX3485AE/
MAX3488AE/MAX3490AE/
MAX3491AE

+3.3V-Powered, ±20kV ESD-Protected,
20Mbps and Slew-Rate-Limited
RS-485/RS-422 Transceivers

Switching Characteristics (MAX3483AE/MAX3488AE) (continued)

($V_{CC} = +3V$ to $+3.6V$, $T_A = T_{MIN}$ to T_{MAX} , unless otherwise specified. Typical values are at $V_{CC} = +3.3V$ and $T_A = +25^\circ C$.) (Notes 2, 3, 5)

PARAMETER	SYMBOL	CONDITIONS	MIN	TYP	MAX	UNITS
Driver Enable from Shutdown to Output Low	$t_{DZH(SHDN)}$	$R_L = 110\Omega$, $C_L = 15pF$, MAX3483AE Figures 4 and 5 (Note 6)			5.5	μs
Time to Shutdown	t_{SHDN}	(Note 8) MAX3483AE	50	340	700	ns
RECEIVER						
Receiver Propagation Delay	t_{RPLH}	$C_L = 15pF$, Figures 6 and 7			200	ns
	t_{RPHL}				200	
Receiver Output Skew	t_{RSKEW}	$C_L = 15pF$, Figures 6 and 7 (Note 6)			30	ns
Maximum Data Rate	DR_{MAX}		250			kbps
Receiver Enable to Output High	t_{RZH}	$R_L = 1k\Omega$, $C_L = 15pF$, MAX3483AE Figure 8 (Note 6)			50	ns
Receiver Enable to Output Low	t_{RZL}	$R_L = 1k\Omega$, $C_L = 15pF$, MAX3483AE Figure 8 (Note 6)			50	ns
Receiver Disable Time from Low	t_{RLZ}	$R_L = 1k\Omega$, $C_L = 15pF$, MAX3483AE Figure 8			50	ns
Receiver Disable Time from High	t_{RHZ}	$R_L = 1k\Omega$, $C_L = 15pF$, MAX3483AE Figure 8			50	ns
Receiver Enable from Shutdown to Output High	$t_{RLZ(SHDN)}$	$R_L = 1k\Omega$, $C_L = 15pF$, MAX3483AE Figure 8 (Note 6)			10	μs
Receiver Enable from Shutdown to Output Low	$t_{RHZ(SHDN)}$	$R_L = 1k\Omega$, $C_L = 15pF$, MAX3483AE Figure 8 (Note 6)			10	μs
Time to Shutdown	t_{SHDN}	(Note 8) MAX3483AE	50	340	800	ns

Note 2: All devices 100% production tested at $T_A = +25^\circ C$. Specifications over temperature are guaranteed by design.

Note 3: All currents into the device are positive; all currents out of the device are negative. All voltages are referenced to ground, unless otherwise noted.

Note 4: ΔV_{OD} and ΔV_{OC} are the changes in V_{OD} and V_{OC} , respectively, when the DI input changes state.

Note 5: Capacitive load includes test probe and fixture capacitance.

Note 6: Guaranteed by design; not production tested.

Note 7: The timing parameter refers to the driver or receiver enable delay, when the device has exited the initial hot-swap protect state and is in normal operating mode.

Note 8: Shutdown is enabled by driving \overline{RE} high and DE low. The device is guaranteed to have entered shutdown after t_{SHDN} has elapsed.

MAX3483AE/MAX3485AE/
 MAX3488AE/MAX3490AE/
 MAX3491AE

+3.3V-Powered, ±20kV ESD-Protected,
 20Mbps and Slew-Rate-Limited
 RS-485/RS-422 Transceivers

Test and Timing Diagrams

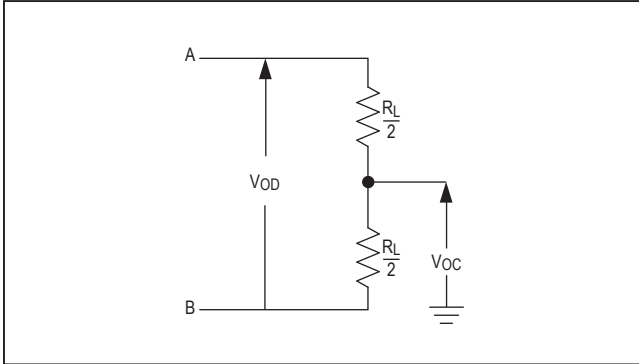

Figure 1. Driver DC Test Load

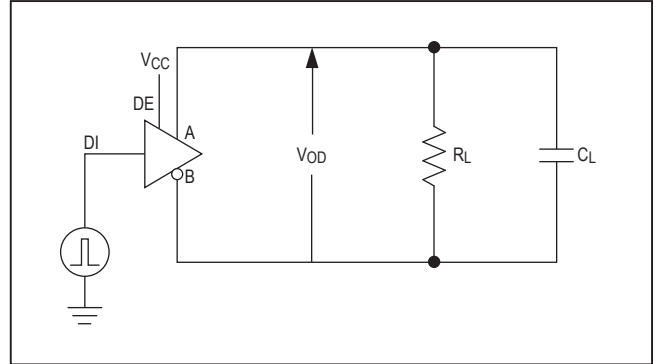

Figure 2. Driver Timing Test Circuit

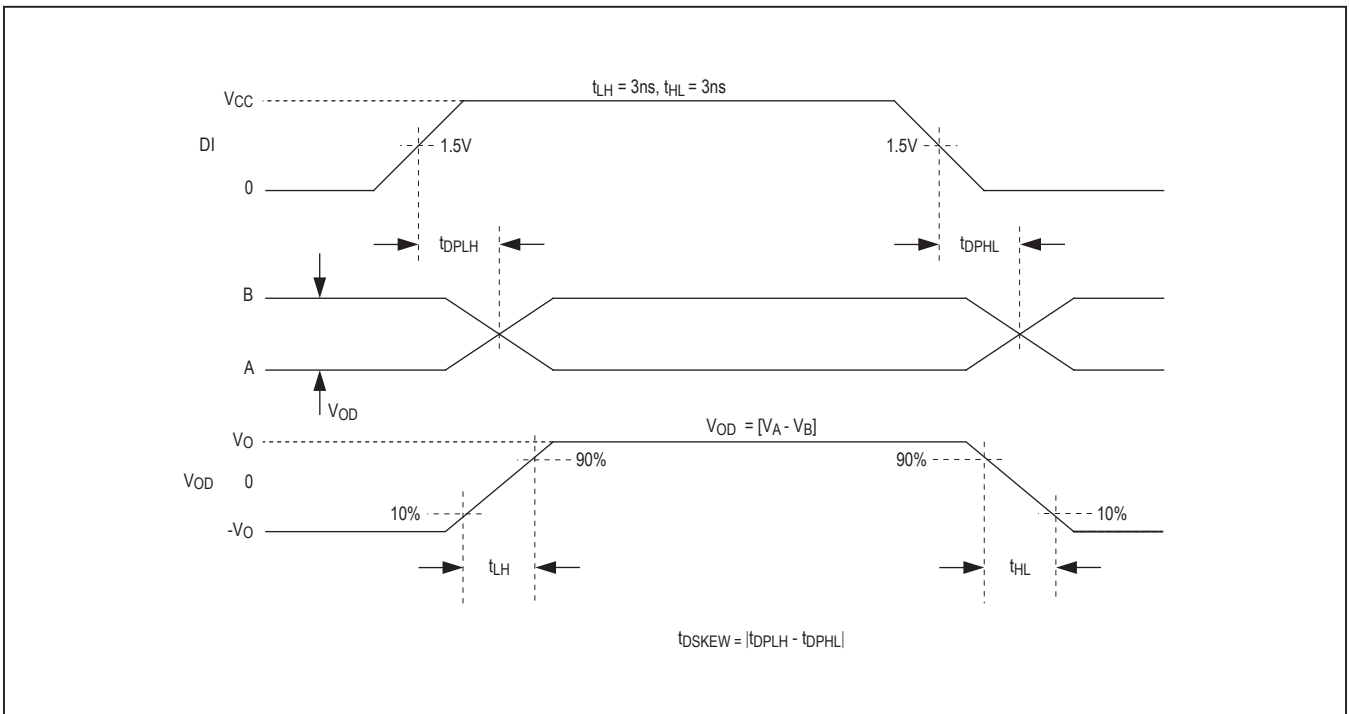

Figure 3. Driver Propagation Delays

MAX3483AE/MAX3485AE/
 MAX3488AE/MAX3490AE/
 MAX3491AE

+3.3V-Powered, ±20kV ESD-Protected,
 20Mbps and Slew-Rate-Limited
 RS-485/RS-422 Transceivers

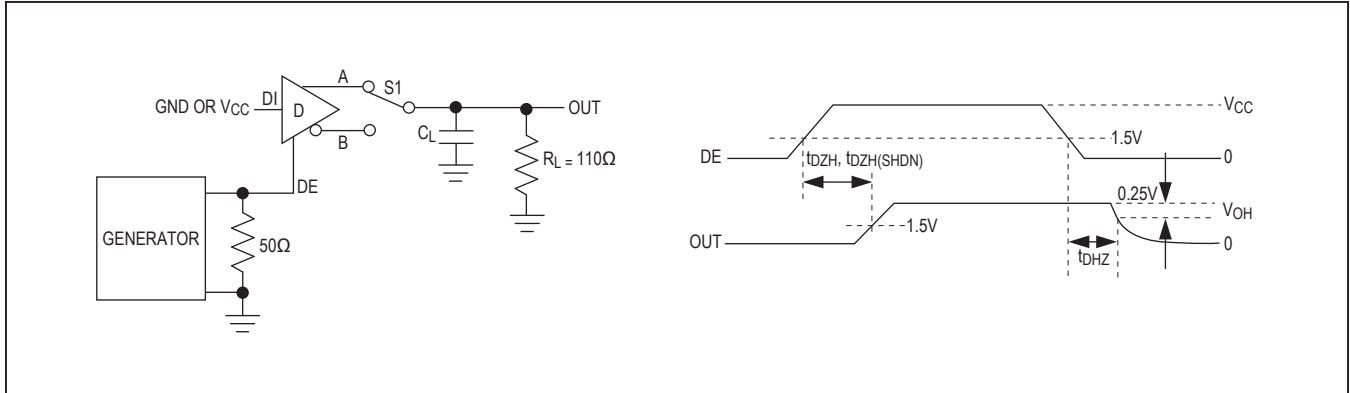

Figure 4. Driver Enable and Disable Times (t_{DZH} , t_{DZL})

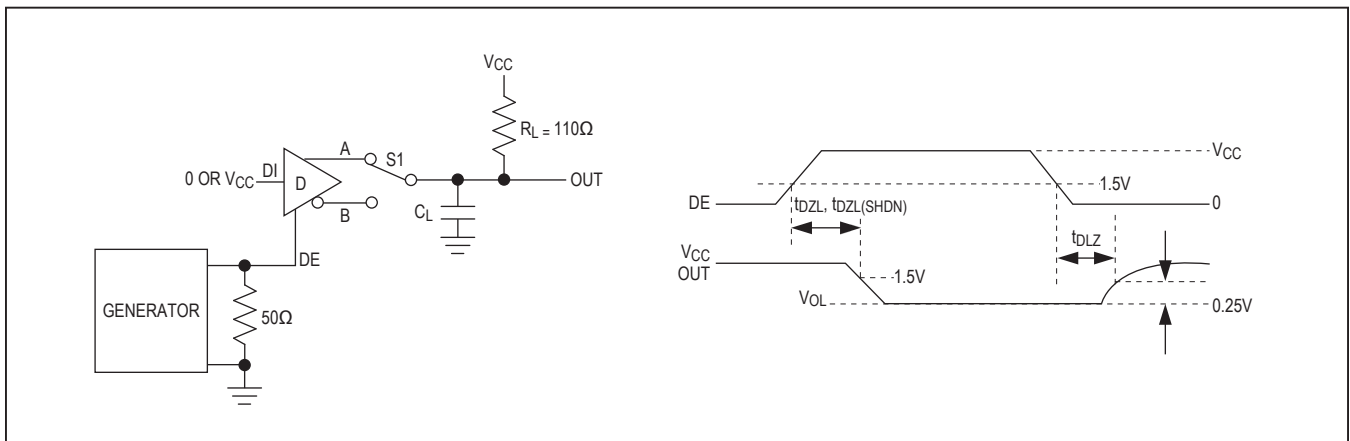

Figure 5. Driver Enable and Disable Times (t_{DLZ} , t_{DLZ})

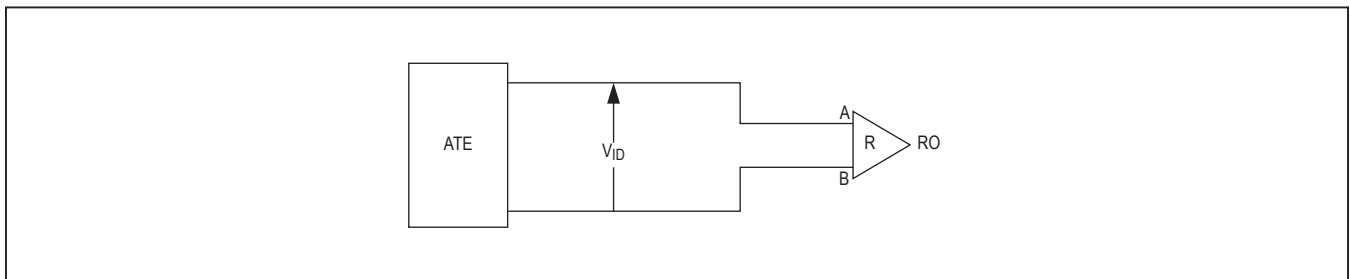

Figure 6. Receiver Propagation Delay Test Circuit

MAX3483AE/MAX3485AE/
 MAX3488AE/MAX3490AE/
 MAX3491AE

+3.3V-Powered, ±20kV ESD-Protected,
 20Mbps and Slew-Rate-Limited
 RS-485/RS-422 Transceivers

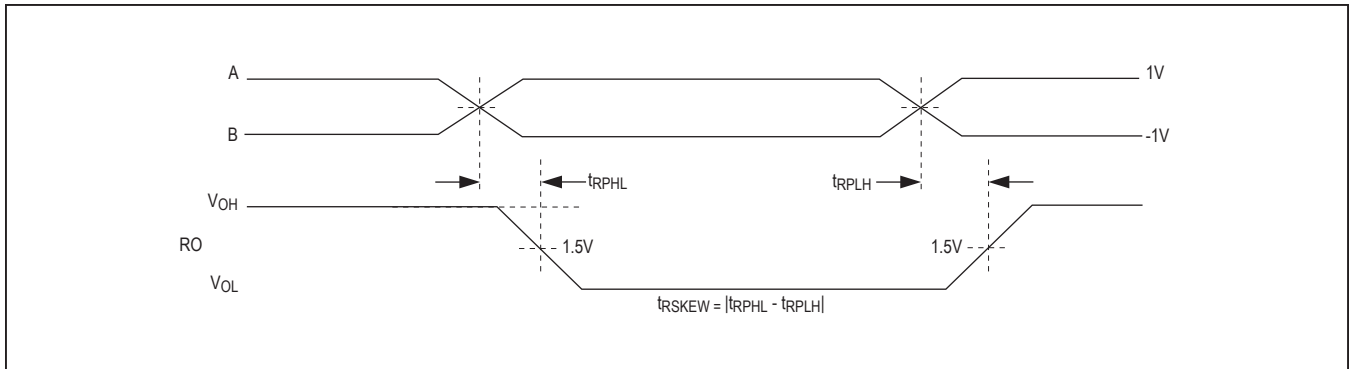

Figure 7. Receiver Propagation Delays

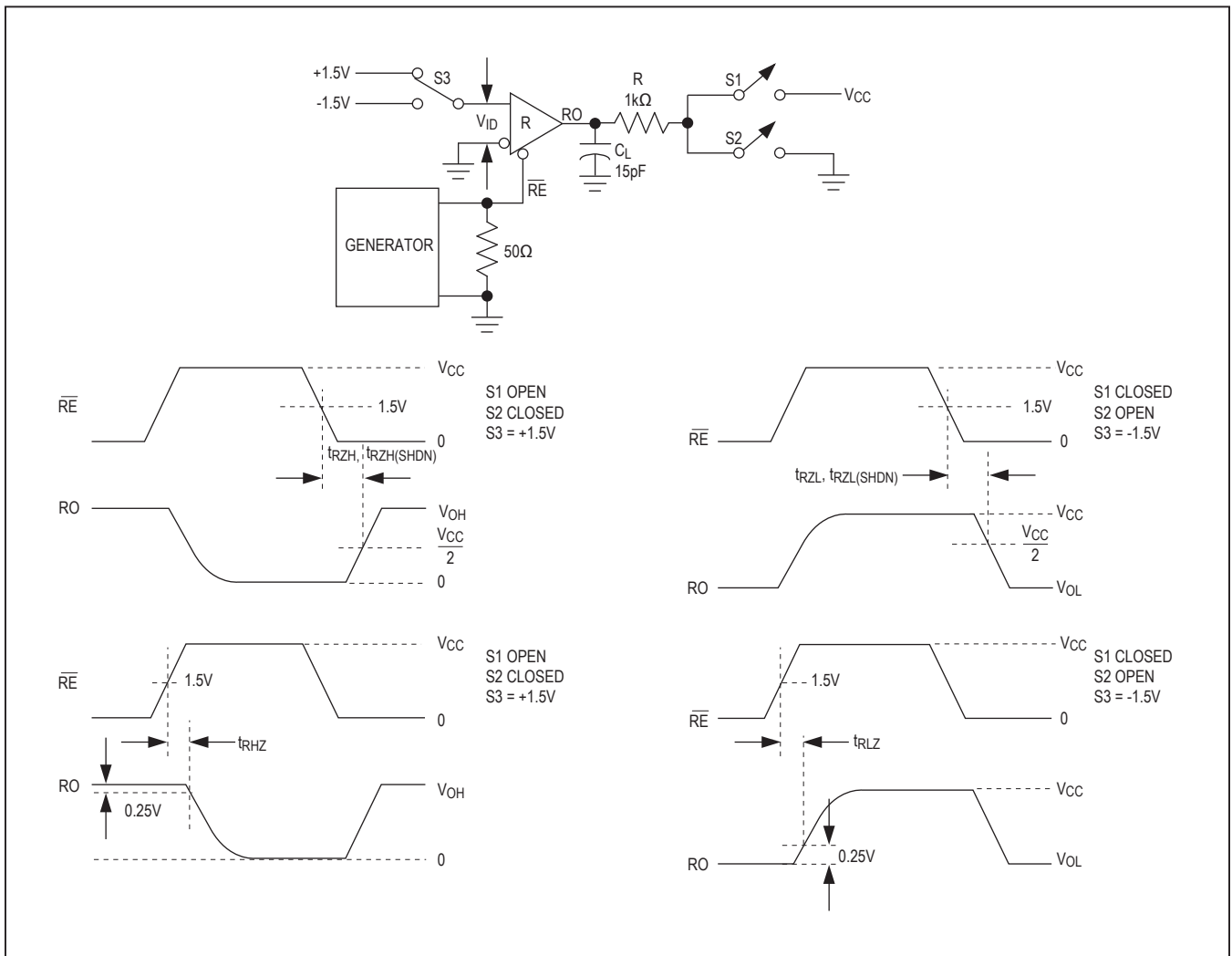

Figure 8. Receiver Enable and Disable Times

MAX3483AE/MAX3485AE/
MAX3488AE/MAX3490AE/
MAX3491AE

+3.3V-Powered, ±20kV ESD-Protected,
20Mbps and Slew-Rate-Limited
RS-485/RS-422 Transceivers

Typical Operating Characteristics

(V_{CC} = +3.3V, T_A = +25°C, unless otherwise specified.)

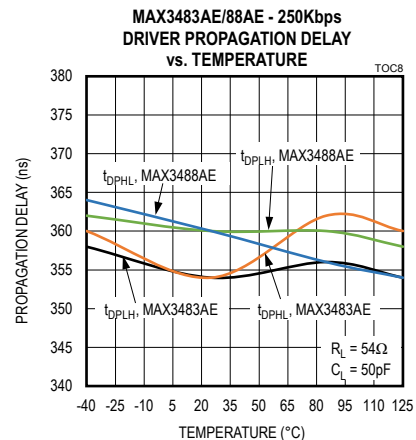
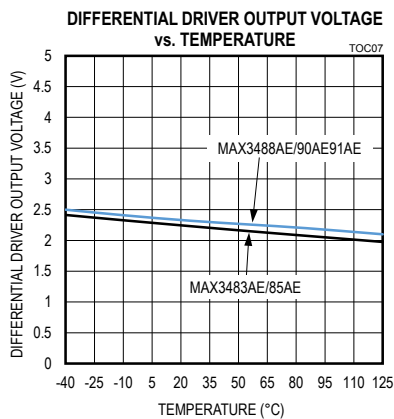
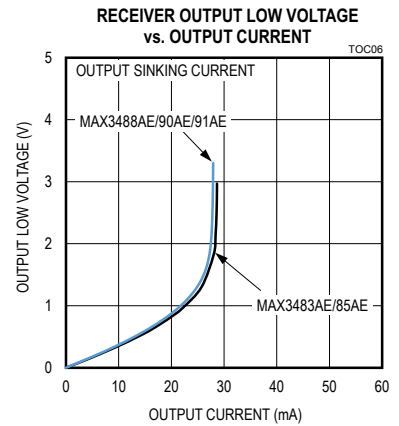
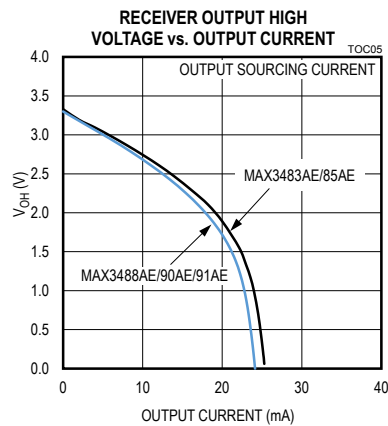
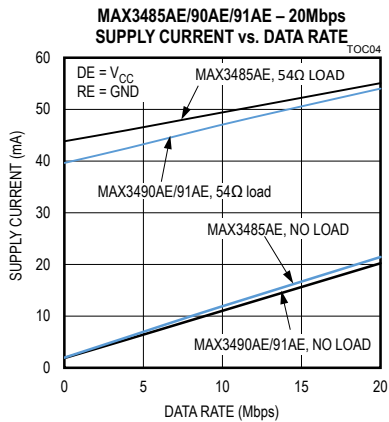
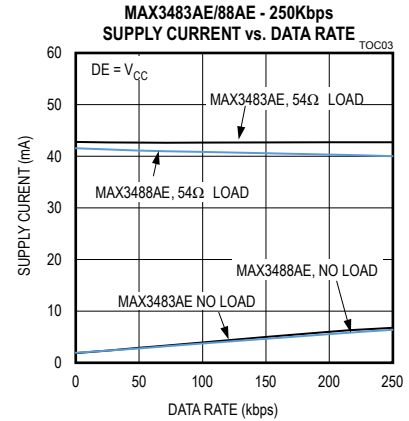
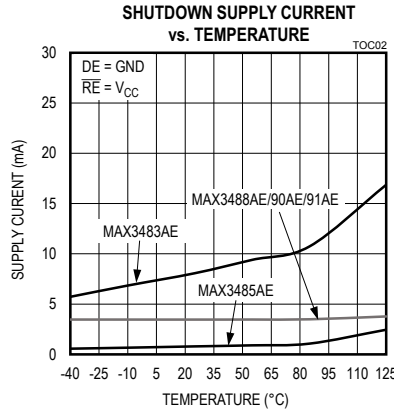
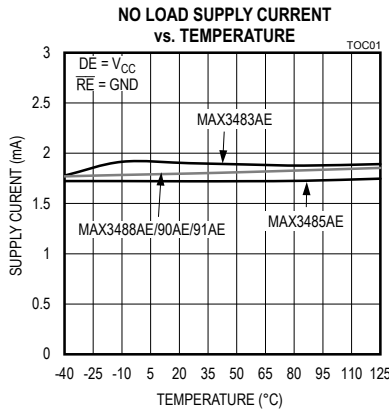

MAX3483AE/MAX3485AE/
MAX3488AE/MAX3490AE/
MAX3491AE

+3.3V-Powered, ±20kV ESD-Protected,
20Mbps and Slew-Rate-Limited
RS-485/RS-422 Transceivers

Typical Operating Characteristics (continued)

(V_{CC} = +3.3V, T_A = +25°C, unless otherwise specified.)

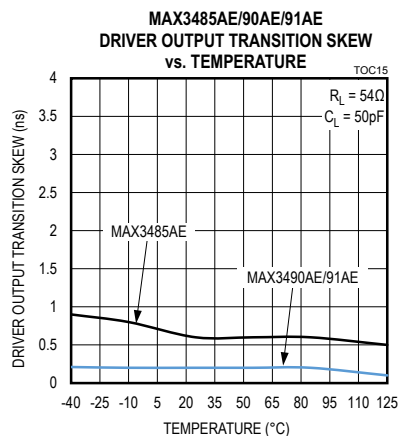
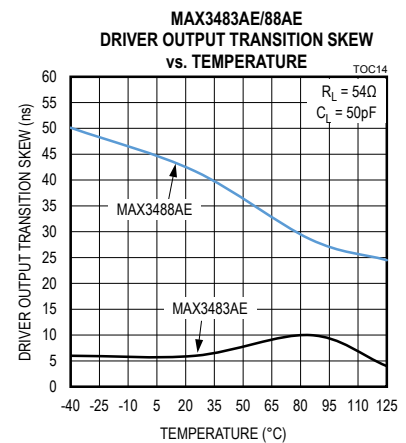
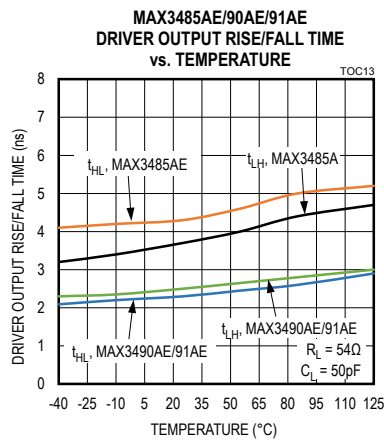
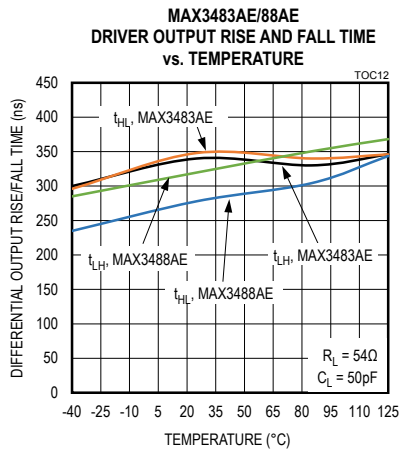
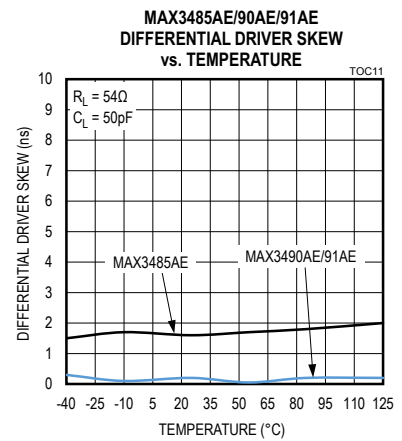
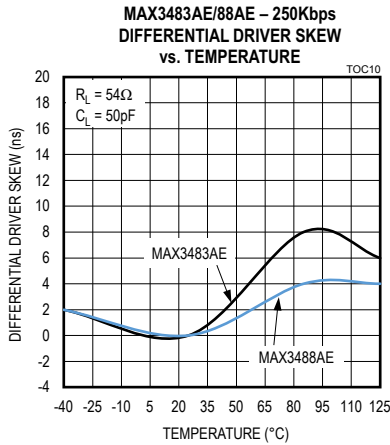
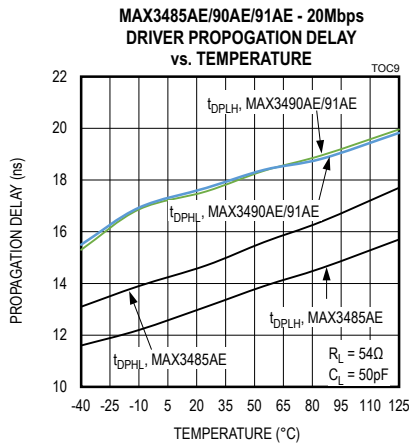

MAX3483AE/MAX3485AE/
MAX3488AE/MAX3490AE/
MAX3491AE

+3.3V-Powered, ±20kV ESD-Protected,
20Mbps and Slew-Rate-Limited
RS-485/RS-422 Transceivers

Pin Configuration

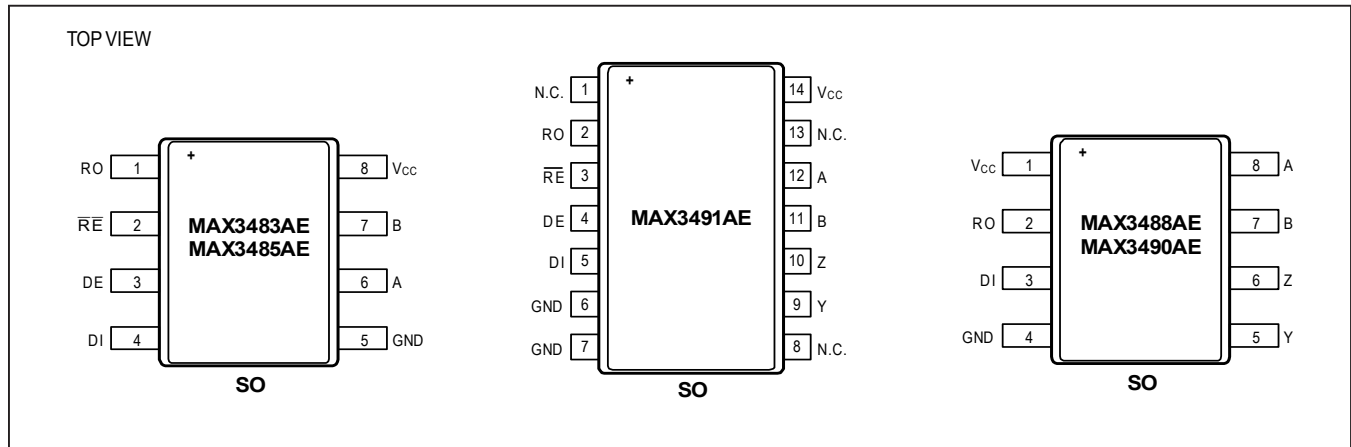

Pin Description

PIN			NAME	FUNCTION
MAX3483AE MAX3485AE	MAX3488AE MAX3490AE	MAX3491AE		
—	—	1, 8, 13	N.C.	No Connection. Not internally connected.
1	2	2	RO	Receiver Output. Drive \overline{RE} low to enable RO. RO is always active on the MAX3488AE and MAX3490AE. RO is high when the receiver inputs ($V_A - V_B$) > -10mV and low when ($V_A - V_B$) \leq 200mV. See the Function Tables.
2	—	3	\overline{RE}	Receiver Output Enable. Drive \overline{RE} low, or leave unconnected, to enable RO. RO is high impedance when \overline{RE} is high. Drive \overline{RE} high and DE low to enter low-power shutdown mode. \overline{RE} has a weak pulldown to GND.
3	—	4	DE	Driver Enable. Drive DE high, or leave unconnected, to enable the driver outputs (Y and Z for full duplex, A and B for half duplex). The driver outputs are high impedance when DE is low. Drive \overline{RE} high and DE low to enter low-power shutdown mode. DE has a weak pullup to V_{CC} .
4	3	5	DI	Driver Input. A low on DI forces the noninverting output (Y or A) low and the inverting output (Z or B) high. Similarly, a high on DI forces the noninverting output (Y or A) high and the inverting output (Z or B) low. See the Function Tables.
5	4	6, 7	GND	Ground
—	5	9	Y	Noninverting Driver Output
—	6	10	Z	Inverting Driver Output
7	7	11	B	Inverting Receiver Input/Driver Output (MAX3483AE/MAX3485AE). Inverting Receiver Input (MAX3488AE/MAX3490AE/MAX3491AE).
6	8	12	A	Noninverting Receiver Input/Driver Output (MAX3483AE/MAX3485AE). Noninverting Receiver Input (MAX3488AE/MAX3490AE/MAX3491AE).
8	1	14	V_{CC}	Positive Supply. Bypass V_{CC} to GND with a 0.1 μ F capacitor as close as possible to the IC.

MAX3483AE/MAX3485AE/
 MAX3488AE/MAX3490AE/
 MAX3491AE

+3.3V-Powered, ±20kV ESD-Protected,
 20Mbps and Slew-Rate-Limited
 RS-485/RS-422 Transceivers

Function Tables (MAX3483AE, MAX3485AE)

TRANSMITTING					
INPUTS			OUTPUTS		MODE
\overline{RE}	DE	DI	B	A	
X	1	1	0	1	Active
X	1	0	1	0	Active
0	0	X	High Impedance		Driver Disabled
1	0	X	High Impedance		Shutdown

RECEIVING				
INPUTS			OUTPUTS	MODE
\overline{RE}	DE	A-B	RO	
0	X	$\geq -10\text{mV}$	1	Active
0	X	$\leq -200\text{mV}$	0	Active
0	X	Open/Shorted	1	Active
1	1	X	High Impedance	Receiver Disabled
1	0	X	High Impedance	Shutdown

X = Don't care

Function Tables MAX3491AE

TRANSMITTING				
INPUTS			OUTPUTS	
\overline{RE}^*	DE*	DI	Y	Z
X	1	1	1	0
X	1	0	0	1
0	0	X	High-Impedance	
1	0	X	Shutdown	

RECEIVING			
INPUTS			OUTPUT
\overline{RE}^*	DE*	$V_A - V_B$	RO
0	X	$\geq -10\text{mV}$	1
0	X	$\leq -200\text{mV}$	0
0	X	Open/Shorted	1
1	1	X	High-Impedance
1	0	X	Shutdown

* \overline{RE} and DE on the MAX3488AE and MAX3490AE are internal. The driver outputs and receiver are always active in these devices.

MAX3483AE/MAX3485AE/
MAX3488AE/MAX3490AE/
MAX3491AE

+3.3V-Powered, $\pm 20\text{kV}$ ESD-Protected,
20Mbps and Slew-Rate-Limited
RS-485/RS-422 Transceivers

Detailed Description

The MAX3483AE/85AE and MAX3488AE/90AE/91AE family are 3.3V ESD-protected RS-485/RS-422 transceivers intended for half-duplex or full-duplex communications. Integrated hot-swap functionality eliminates false transitions on the bus during power-up or hot insertion.

The device features fail-safe receiver inputs guaranteeing a logic-high receiver output when inputs are shorted or open. The MAX3483AE/85AE has a 1-unit load receiver input impedance, allowing up to 32 transceivers on the bus. The MAX3488AE/90AE/91AE has a 1/4-unit load receiver input impedance, allowing up to 128 transceivers on the bus.

True Fail Safe

The transceiver family guarantee a logic-high receiver output when the receiver inputs are shorted or open, or when they are connected to a terminated transmission line with all drivers disabled. If the differential receiver input voltage (A-B) is greater than or equal to -10mV , RO is logic-high.

Driver Single-Ended Operation

The driver outputs can either be used in the standard differential operating mode, or can be used as single-ended outputs. Since the driver outputs swing rail-to-rail, they can individually be used as standard TTL logic outputs.

For half-duplex transceivers, driver outputs are A and B. For full-duplex transceivers, driver outputs are Y and Z.

Hot-Swap Capability

Hot-Swap Inputs

When circuit boards are inserted in a hot or powered backplane, disturbances on the enable inputs and differential receiver inputs can lead to data errors. Upon initial circuit board insertion, the processor undergoes its power-up sequence. During this period, the processor output drivers are high impedance and are unable to drive the DE and $\overline{\text{RE}}$ inputs MAX3483AE/85AE/91AE to a defined logic level. Leakage currents up to $10\mu\text{A}$ from the high-impedance outputs of a controller could cause DE and $\overline{\text{RE}}$ to drift to an incorrect logic state. Additionally, parasitic circuit board capacitance could cause coupling of V_{CC} or GND to DE and $\overline{\text{RE}}$. These factors could improperly enable the driver or receiver. The integrated hot-swap inputs help to avoid these potential problems.

When V_{CC} rises, an internal pulldown circuit holds DE low and $\overline{\text{RE}}$ high. After the initial power-up sequence, the pulldown circuit becomes transparent, resetting the hot-swap-tolerable inputs.

Hot-Swap Input Circuitry

The DE and $\overline{\text{RE}}$ enable inputs feature hot-swap capability. At the input, there are two nMOS devices, M1 and M2 (Figure 9). When V_{CC} ramps from 0V, an internal $10\mu\text{s}$ timer turns on M2 and sets the SR latch that also turns on M1. Transistors M2 (a $500\mu\text{A}$ current sink) and M1 (a $100\mu\text{A}$ current sink) pull DE to GND through a $5\text{k}\Omega$ (typ)

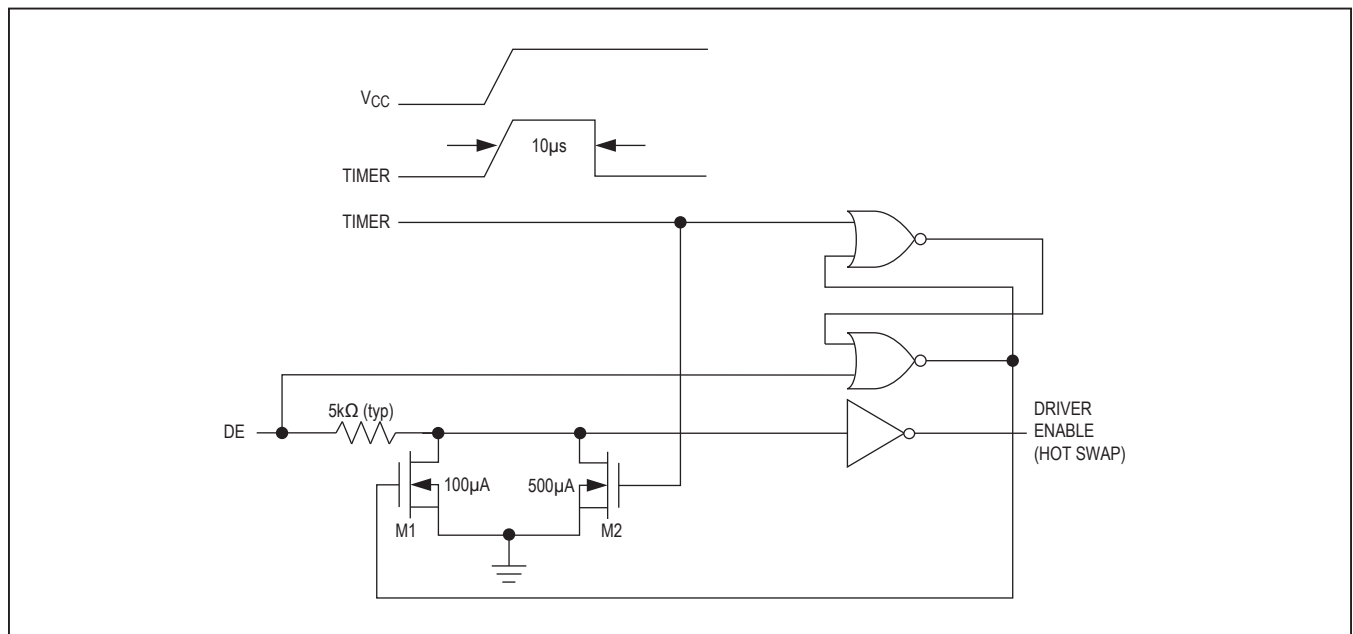

Figure 9. Simplified Structure of the Driver Enable (DE) Pin

MAX3483AE/MAX3485AE/
MAX3488AE/MAX3490AE/
MAX3491AE

resistor. M2 is designed to pull DE to the disabled state against an external parasitic capacitance up to 100pF that can drive DE high. After 10μs, the timer deactivates M2 while M1 remains on, holding DE low against three-state leakages that can drive DE high. M1 remains on until an external source overcomes the required input current. At this time, the SR latch resets and M1 turns off. When M1 turns off, DE reverts to a standard, high-impedance CMOS input. Whenever V_{CC} drops below 1V, the hot-swap input is reset.

A complementary circuit employing two pMOS devices pulls RE to V_{CC}.

±20kV ESD Protection

ESD protection structures are incorporated on all pins to protect against electrostatic discharges encountered during handling and assembly. The driver outputs and receiver inputs have extra protection against static electricity. The ESD structures withstand high ESD in all states: normal operation, shutdown, and powered down. After an ESD event, the transceiver family keeps working without latch-up or damage.

ESD protection can be tested in various ways. The transmitter outputs and receiver inputs are characterized for protection to the following limits:

+3.3V-Powered, ±20kV ESD-Protected,
20Mbps and Slew-Rate-Limited
RS-485/RS-422 Transceivers

- ±20kV HBM using JEDEC JS-001-2014.
- ±15kV using the Air-Gap Discharge method specified in IEC 61000-4-2.
- ±8kV using the Contact Discharge method specified in IEC 61000-4-2.

ESD Test Conditions

ESD performance depends on a variety of conditions. Contact Maxim for a reliability report that documents test setup, test methodology, and test results.

Human Body Model (HBM)

Figure 10 shows the HBM, and Figure 11 shows the current waveform it generates when discharged into a low-impedance state. This model consists of a 100pF capacitor charged to the ESD voltage of interest, which is then discharged into the test device through a 1.5kΩ resistor.

IEC 61000-4-2

The IEC 61000-4-2 standard covers ESD testing and performance of finished equipment. However, it does not specifically refer to integrated circuits. The transceiver family helps in designing equipment to meet IEC 61000-4-2 without the need for additional ESD protection components.

The major difference between tests done using the HBM and IEC 61000-4-2 is higher peak current in IEC 61000-4-2 because series resistance is lower in the IEC 61000-4-2 model. Hence, the ESD withstand voltage measured to IEC 61000-4-2 is generally lower than that measured using the HBM.

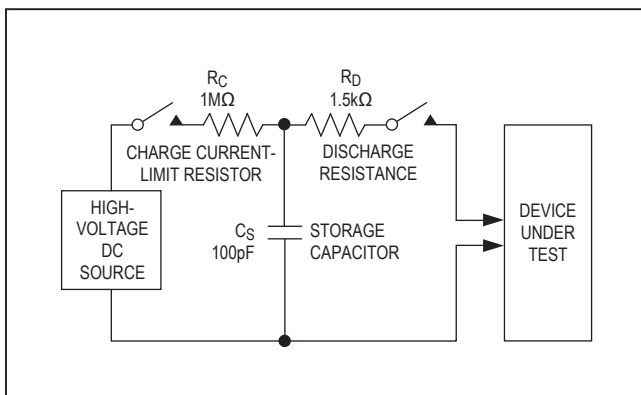

Figure 10. Human Body ESD Test Model

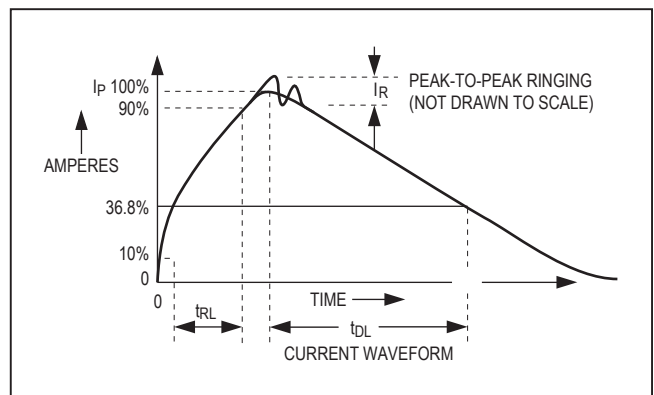

Figure 11. Human Body Current Waveform

MAX3483AE/MAX3485AE/
MAX3488AE/MAX3490AE/
MAX3491AE

+3.3V-Powered, ±20kV ESD-Protected,
20Mbps and Slew-Rate-Limited
RS-485/RS-422 Transceivers

Figure 12 shows the IEC 61000-4-2 model, and Figure 13 shows the current waveform for IEC 61000-4-2 ESD Contact Discharge test.

Applications Information

Driver Output Protection

Two mechanisms prevent excessive output current and power dissipation caused by faults or by bus connection. The first, a current limit on the output stage provides immediate protection against short circuits over the whole common-mode voltage range. The second, a thermal-shutdown circuit, forces the driver outputs into a high-impedance state if the die temperature exceeds +160°C (typ).

Low-Power Shutdown Mode (MAX3483AE, MAX3485AE, MAX3491AE)

Low-power shutdown mode is initiated by bringing \overline{RE} high and DE low. In shutdown, the devices draw less than 10µA of supply current.

\overline{RE} and DE can be connected together and driven simultaneously. The transceiver is guaranteed not to enter shutdown if \overline{RE} is high and DE is low for less than 50ns. If the inputs are in this state for at least 800ns (max), the device is guaranteed to enter shutdown.

Typical Applications

The transceiver family is designed for bidirectional data communications on multipoint bus transmission lines. Figure 14 and Figure 15 show typical network application circuits. To minimize reflections, terminate the line at both ends with its characteristic impedance and keep stub lengths off the main line as short as possible.

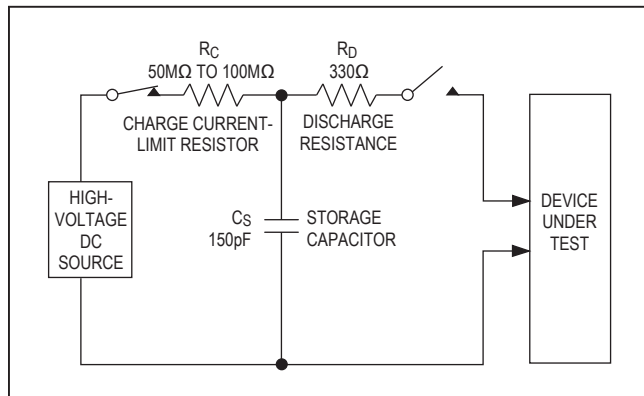

Figure 12. IEC 61000-4-2 ESD Test Model

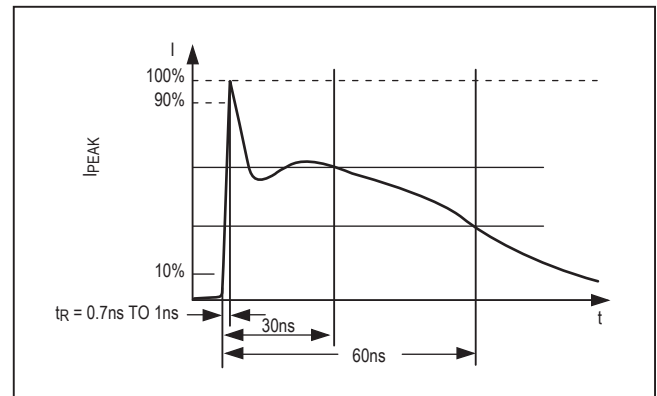

Figure 13. IEC 61000-4-2 ESD Generator Current Waveform

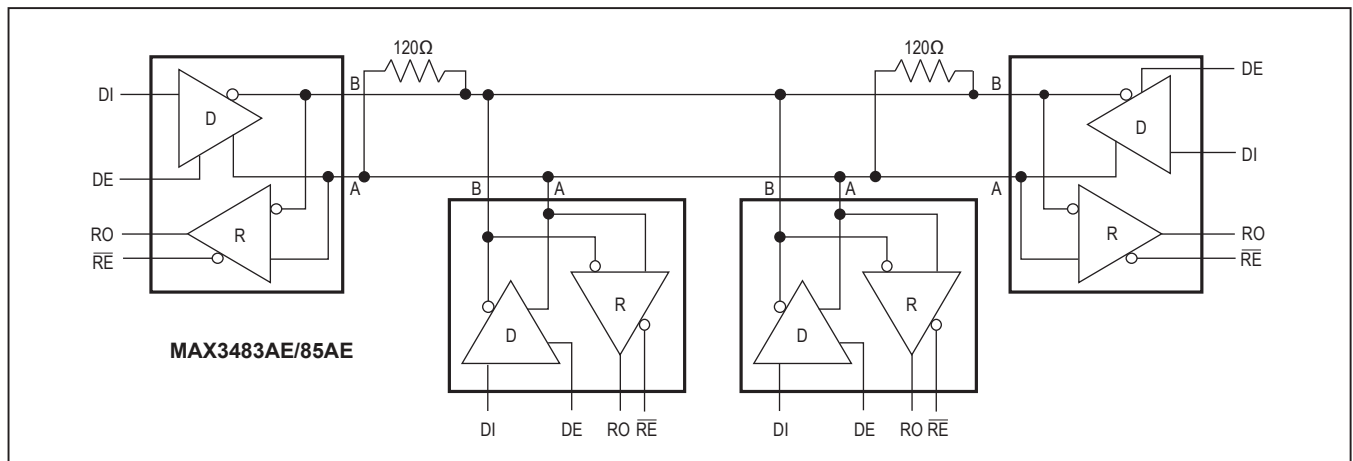

Figure 14. Typical Half-Duplex Application Circuit

MAX3483AE/MAX3485AE/
 MAX3488AE/MAX3490AE/
 MAX3491AE

+3.3V-Powered, ±20kV ESD-Protected,
 20Mbps and Slew-Rate-Limited
 RS-485/RS-422 Transceivers

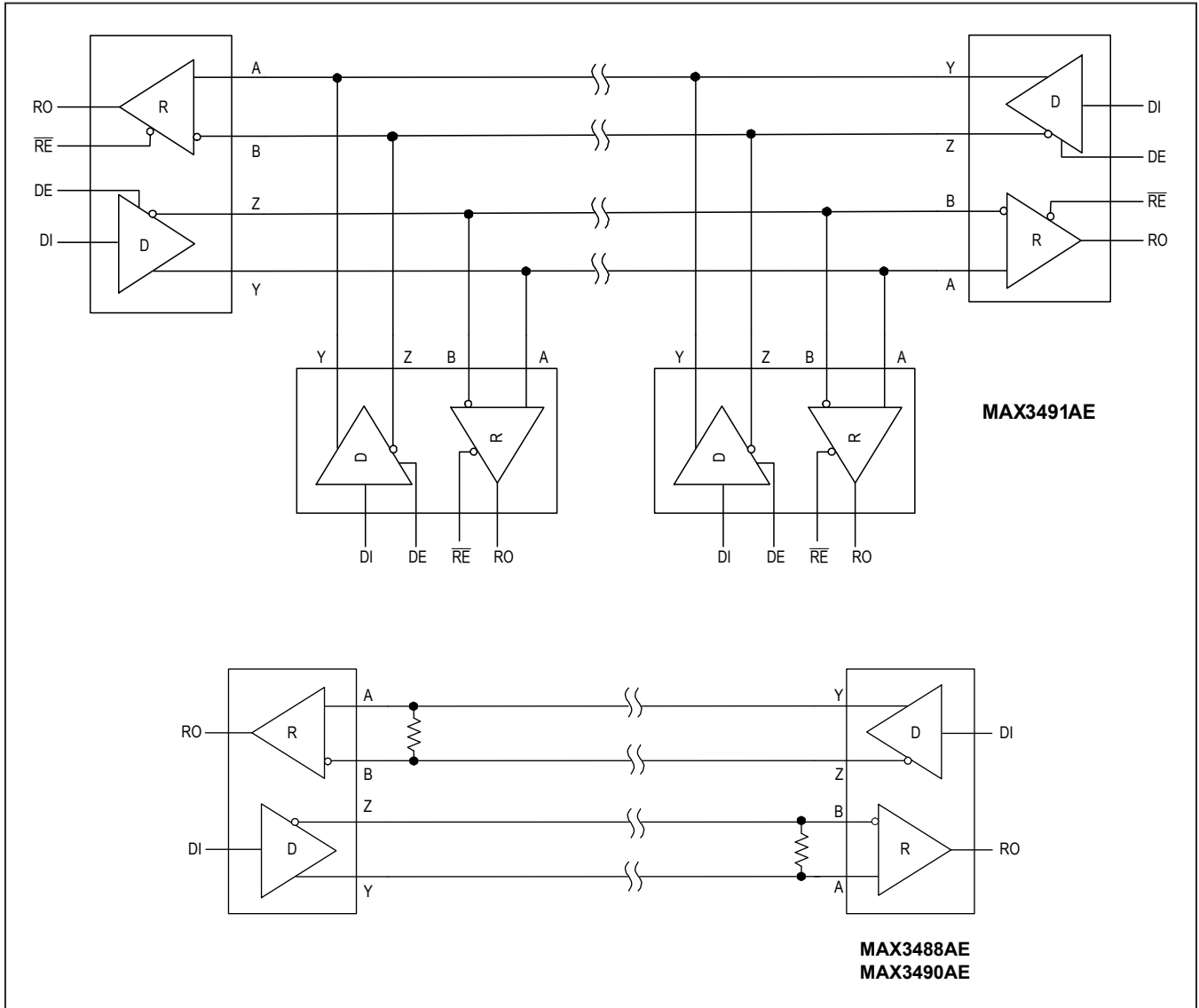

Figure 15. Typical Full-Duplex RS-485 Network

MAX3483AE/MAX3485AE/
MAX3488AE/MAX3490AE/
MAX3491AE

+3.3V-Powered, ±20kV ESD-Protected,
20Mbps and Slew-Rate-Limited
RS-485/RS-422 Transceivers

Chip Information

PROCESS: BiCMOS

Package Information

For the latest package outline information and land patterns (footprints), go to www.maximintegrated.com/packages. Note that a "+", "#", or "-" in the package code indicates RoHS status only. Package drawings may show a different suffix character, but the drawing pertains to the package regardless of RoHS status.

PACKAGE TYPE	PACKAGE CODE	OUTLINE NO.	LAND PATTERN NO.
8 SOIC	S8+2	21-0041	90-0096
8 SOIC	S8+4	21-0041	90-0096
14 SOIC	S14+1	21-0041	90-0112

Ordering Information

PART	DUPLEX	DATA RATE (MAX)	PIN-PACKAGE	PACKAGE CODE	TEMPERATURE RANGE	NODES
MAX3483AEASA+	Half	0.25Mbps	8 SO	S8+2	-40°C to +125°C	32
MAX3485AEASA+	Half	20Mbps	8 SO	S8+2	-40°C to +125°C	32
MAX3488AEGSA+	Full	0.25Mbps	8 SO	S8+4	-40°C to +105°C	128
MAX3490AEGSA+	Full	20Mbps	8 SO	S8+4	-40°C to +105°C	128
MAX3491AEASD+	Full	20Mbps	14 SO	S14+1	-40°C to +125°C	128

+Denotes lead(Pb)-free/RoHS-compliant package.

MAX3483AE/MAX3485AE/
MAX3488AE/MAX3490AE/
MAX3491AE

+3.3V-Powered, ±20kV ESD-Protected,
20Mbps and Slew-Rate-Limited
RS-485/RS-422 Transceivers

Revision History

REVISION NUMBER	REVISION DATE	DESCRIPTION	PAGES CHANGED
0	3/16	Initial release	—
1	9/17	Updated <i>General Description</i> , <i>Functional Diagram</i> , <i>Absolute Maximum Ratings</i> , <i>Electrical Characteristics</i> table, various figures, and <i>Ordering Information</i> table	1–6, 8, 10–12, 15–18

For pricing, delivery, and ordering information, please contact Maxim Direct at 1-888-629-4642, or visit Maxim Integrated's website at www.maximintegrated.com.

Maxim Integrated cannot assume responsibility for use of any circuitry other than circuitry entirely embodied in a Maxim Integrated product. No circuit patent licenses are implied. Maxim Integrated reserves the right to change the circuitry and specifications without notice at any time. The parametric values (min and max limits) shown in the Electrical Characteristics table are guaranteed. Other parametric values quoted in this data sheet are provided for guidance.