



±60V Fault-Protected, 10Mbps, Fail-Safe RS-485 Transceiver with ±15kV ESD Protection

General Description

The MAX3443E fault-protected RS-485/RS-422 transceiver features ±60V protection from signal faults on communication bus lines. Each device contains one differential line driver with three-state output, and one differential line receiver with three-state input. The 1/4-unit-load receiver input impedance allows up to 128 transceivers on a single bus. The device operates from a 5V supply at data rates up to 10Mbps. True fail-safe inputs guarantee a logic-high receiver output when the receiver inputs are open, shorted, or connected to an idle data line.

Hot-swap circuitry eliminates false transitions on the data cable during circuit initialization or connection to a live backplane. Short-circuit current limiting and thermal shutdown circuitry protect the driver against excessive power dissipation, and integrated ±15kV ESD protection eliminates costly external protection devices.

The MAX3443E is available in 8-pin SO and PDIP packages, and is specified over commercial, industrial, and automotive temperature ranges.

Applications

RS-422/RS-485 Communications
Industrial Networks
Telecommunication Systems
Automotive Applications
HVAC Controls

Features

- ◆ ±60V Fault Protection
- ◆ ±15kV ESD Protection
- ◆ Guaranteed 10Mbps Data Rate
- ◆ Allows Up to 128 Transceivers on the Bus
- ◆ -7V to +12V Common-Mode Input Range
- ◆ True Fail-Safe Receiver Inputs
- ◆ Hot-Swap Inputs for Telecom Applications
- ◆ Automotive Temperature Range (-40°C to +125°C)
- ◆ Industry-Standard Pinout

Ordering Information

PART	TEMP RANGE	PIN-PACKAGE
MAX3443ECSA	0°C to +70°C	8 SO
MAX3443ECPA	0°C to +70°C	8 PDIP
MAX3443EESA	-40°C to +85°C	8 SO
MAX3443E EPA	-40°C to +85°C	8 PDIP
MAX3443EASA	-40°C to +125°C	8 SO
MAX3443EAPA	-40°C to +125°C	8 PDIP

Pin Configuration and Typical Operating Circuit

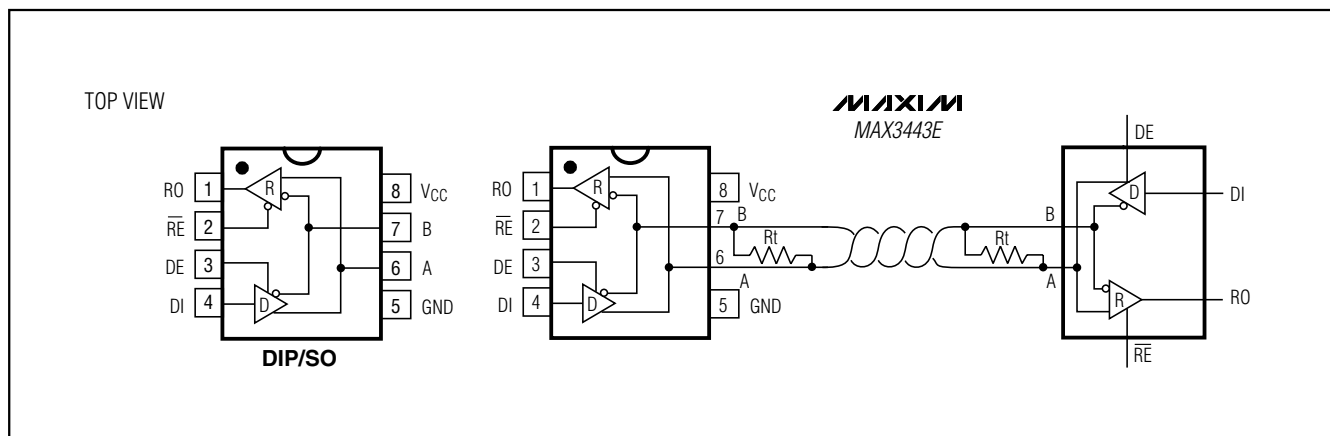

±60V Fault-Protected, 10Mbps, Fail-Safe RS-485 Transceiver with ±15kV ESD Protection

ABSOLUTE MAXIMUM RATINGS

All Voltages Referenced with Respect to GND

V _{CC}	+7V
RE, DE, DI	-0.3V to (V _{CC} + 0.3V)
A, B (Note 1)	±60V
RO	-0.3V to (V _{CC} + 0.3V)
Continuous Power Dissipation (T _A = +70°C)	
8-Pin SO (derate 5.9mW/°C above +70°C)	471mW
8-Pin PDIP (derate 9.09mW/°C above +70°C)	727mW

Operating Temperature Ranges

MAX3443EC _ _	0°C to +70°C
MAX3443EE _ _	-40°C to +85°C
MAX3443EA _ _	-40°C to +125°C
Storage Temperature Range	-65°C to +150°C
Short-Circuit Duration (RO, A, B)	Continuous
Lead Temperature (soldering, 10s)	+300°C

Note 1: A, B must be terminated with 54Ω or 100Ω to guarantee ±60V fault protection.

Stresses beyond those listed under "Absolute Maximum Ratings" may cause permanent damage to the device. These are stress ratings only, and functional operation of the device at these or any other conditions beyond those indicated in the operational sections of the specifications is not implied. Exposure to absolute maximum rating conditions for extended periods may affect device reliability.

DC ELECTRICAL CHARACTERISTICS

(V_{CC} = +4.75V to +5.25V, T_A = T_{MIN} to T_{MAX}, unless otherwise noted. Typical values are at V_{CC} = +5V and T_A = +25°C.)

PARAMETER	SYMBOL	CONDITIONS	MIN	TYP	MAX	UNITS
DRIVER						
Differential Driver Output	V _{OD}	Figure 1, R _L = 50Ω	2.0		V _{CC}	V
		Figure 1, R _L = 27Ω	1.5		V _{CC}	
Change in Magnitude of Differential Output Voltage	ΔV _{OD}	Figure 1, R _L = 50Ω or 27Ω (Note 2)			0.2	V
Driver Common-Mode Output Voltage	V _{OC}	Figure 1, R _L = 50Ω or 27Ω		V _{CC} / 2	3	V
Change In Magnitude of Common-Mode Voltage	ΔV _{OC}	Figure 1, R _L = 50Ω or 27Ω (Note 2)			0.2	V
DRIVER LOGIC						
Driver Input High Voltage	V _{DIH}		2.0			V
Driver Input Low Voltage	V _{DIL}				0.8	V
Driver Input Current	I _{DIN}				±2	μA
Driver Output Fault Current	I _{OFC}	V _{A, B} = ±60V, R _L = 54Ω			±6	mA
Driver Short-Circuit Output Current	I _{OSD}	-7V ≤ V _{OUT} ≤ +12V (Note 3)			±350	mA
Driver Short-Circuit Foldback Output Current	I _{OSDF}	-7V ≤ V _{OUT} ≤ +12V (Note 3)			±25	mA
RECEIVER						
Input Current	I _{A, B}	A, B	DE = GND, V _{CC} = GND, V _{A, B} = +12V		250	μA
			V _{A, B} = -7V		-150	
			V _{A, B} = ±60V		±6	mA
Receiver Differential Threshold Voltage	V _{TH}	-7V ≤ V _{CM} ≤ +12V	-200		-50	mV
Receiver Input Hysteresis	ΔV _{TH}			25		mV

±60V Fault-Protected, 10Mbps, Fail-Safe RS-485 Transceiver with ±15kV ESD Protection

DC ELECTRICAL CHARACTERISTICS (continued)

($V_{CC} = +4.75V$ to $+5.25V$, $T_A = T_{MIN}$ to T_{MAX} , unless otherwise noted. Typical values are at $V_{CC} = +5V$ and $T_A = +25^{\circ}C$.)

PARAMETER	SYMBOL	CONDITIONS	MIN	TYP	MAX	UNITS
RECEIVER LOGIC						
Output High Voltage	V_{OH}	Figure 2, $I_{OH} = -1.6mA$	$V_{CC} - 0.6$			V
Output Low Voltage	V_{OL}	Figure 2, $I_{OL} = 1mA$			0.4	V
Three-State Output Current at Receiver	I_{OZR}	$0 \leq V_A, B \leq V_{CC}$			±1	μA
Receiver Input Resistance	R_{IN}	$-7V \leq V_{CM} \leq +12V$	48			kΩ
Receiver Output Short-Circuit Current	I_{OSR}	$0 \leq V_{RO} \leq V_{CC}$			±95	mA
CONTROL						
Control Input High Voltage	V_{CIH}	DE, \overline{RE}	2.0			V
Input Current DE Current Latch During First DE Rising Edge				90		μA
Input Current \overline{RE} Current Latch During First \overline{RE} Falling Edge				90		μA

PROTECTION SPECIFICATIONS

($V_{CC} = +4.75V$ to $+5.25V$, $T_A = T_{MIN}$ to T_{MAX} , unless otherwise noted. Typical values are at $V_{CC} = +5V$ and $T_A = +25^{\circ}C$.)

PARAMETER	SYMBOL	CONDITIONS	MIN	TYP	MAX	UNITS
Oversvoltage Protection		A, B $R_{SOURCE} = 0, R_L = 54\Omega$	±60			V
ESD Protection	A, B	IEC 1000-4-2 Air-Gap Discharge	±2			kV
		IEC 1000-4-2 Contact Discharge	±8			
		Human Body Model	±15			
SUPPLY CURRENT						
Normal Operation	I_Q	No load, $DI = V_{CC}$ or GND, $\overline{RE} = GND$, $DE = V_{CC}$			10	mA
Supply Current in Shutdown Mode	I_{SHDN}	$DE = GND, \overline{RE} = V_{CC}$			10	μA
Supply Current with Output Shorted with ±60V	I_{SHRT}	$DE = GND, \overline{RE} = GND$, output in three-state			±15	mA

±60V Fault-Protected, 10Mbps, Fail-Safe RS-485 Transceiver with ±15kV ESD Protection

SWITCHING CHARACTERISTICS (DRIVER)

(V_{CC} = +4.75V to +5.25V, T_A = T_{MIN} to T_{MAX}, unless otherwise noted. Typical values are at V_{CC} = +5V and T_A = +25°C.)

PARAMETER	SYMBOL	CONDITIONS	MIN	TYP	MAX	UNITS
Driver Propagation Delay	t _{PLHA} , t _{PLHB}	Figure 3, R _L = 27Ω, C _L = 50pF			60	ns
Driver Differential Propagation Delay	t _{DPLH} , t _{DPHL}	Figure 4, R _L = 54Ω, C _L = 50pF			60	ns
Driver Differential Output Transition Time	t _{LH} , t _{HL}	Figure 4, R _L = 54Ω, C _L = 50pF			25	ns
Driver Output Skew	t _{SKEWAB} , t _{SKEWBA}	R _L = 54Ω, C _L = 50pF, t _{SKEWAB} = t _{PLHA} - t _{PHLB} , t _{SKEWBA} = t _{PLHB} - t _{PHLA}			10	ns
Differential Driver Output Skew	t _{DSKEW}	R _L = 54Ω, C _L = 50pF, t _{DSKEW} = t _{DPLH} - t _{DPHL}			10	ns
Maximum Data Rate	f _{MAX}		10			Mbps
Driver Enable Time to Output High	t _{PDZH}	Figure 5, R _L = 500Ω, C _L = 50pF			1200	ns
Driver Disable Time from Output High	t _{PDHZ}	Figure 5, R _L = 500Ω, C _L = 50pF			1200	ns
Driver Wake Time from Shutdown to Output High	t _{PDHS}	Figure 5, R _L = 500Ω, C _L = 50pF			4.2	μs
Driver Enable Time to Output Low	t _{PDZL}	Figure 6, R _L = 500Ω, C _L = 50pF			1200	ns
Driver Disable Time from Output Low	t _{PDLZ}	Figure 6, R _L = 500Ω, C _L = 50pF			1200	ns
Driver Wake Time from Shutdown to Output Low	t _{PDLs}	Figure 6, R _L = 500Ω, C _L = 50pF			4.2	μs
Time to Shutdown	t _{SHDN}	R _L = 500Ω, C _L = 50pF			800	ns

±60V Fault-Protected, 10Mbps, Fail-Safe RS-485 Transceiver with ±15kV ESD Protection

SWITCHING CHARACTERISTICS (RECEIVER)

(V_{CC} = +4.75V to +5.25V, T_A = T_{MIN} to T_{MAX}, unless otherwise noted. Typical values are at V_{CC} = +5V and T_A = +25°C.)

PARAMETER	SYMBOL	CONDITIONS	MIN	TYP	MAX	UNITS
Receiver Propagation Delay	t _{RPLH} , t _{RPHL}	Figure 7, C _L = 20pF, V _{ID} = 2V, V _{CM} = 0			75	ns
Receiver Output Skew	t _{RSKEW}	C _L = 20pF, t _{RSKEW} = t _{RPLH} - t _{RPHL}			15	ns
Receiver Enable Time to Output High	t _{RPZH}	Figure 8, R _L = 1kΩ, C _L = 20pF			400	ns
Receiver Disable Time from Output High	t _{RPHZ}	Figure 8, R _L = 1kΩ, C _L = 20pF			400	ns
Receiver Wake Time from Shutdown to Output High	t _{RPSH}	Figure 8, R _L = 1kΩ, C _L = 20pF			4.2	μs
Receiver Enable Time to Output Low	t _{RPZL}	Figure 8, R _L = 1kΩ, C _L = 20pF			400	ns
Receiver Disable Time from Output Low	t _{RPLZ}	Figure 8, R _L = 1kΩ, C _L = 20pF			400	ns
Receiver Wake Time from Shutdown to Output Low	t _{RPSL}	Figure 8, R _L = 1kΩ, C _L = 20pF			4.2	μs
Time to Shutdown					800	ns

Note 2: ΔV_{OD} and ΔV_{OC} are the changes in V_{OD} and V_{OC}, respectively, when the DI input changes state.

Note 3: The short-circuit output current applies to peak current just prior to foldback current limiting; the short-circuit foldback output current applies during current limiting to allow a recovery from bus contention.

Typical Operating Characteristics

(V_{CC} = +5V, T_A = +25°C, unless otherwise noted.)

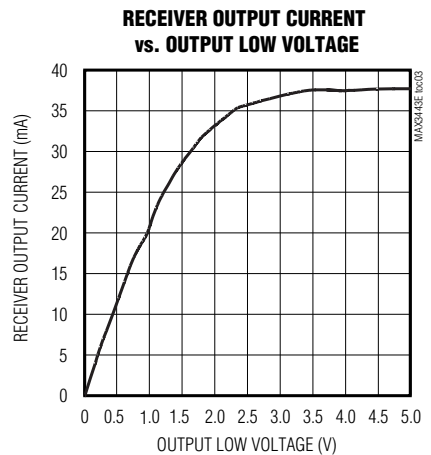
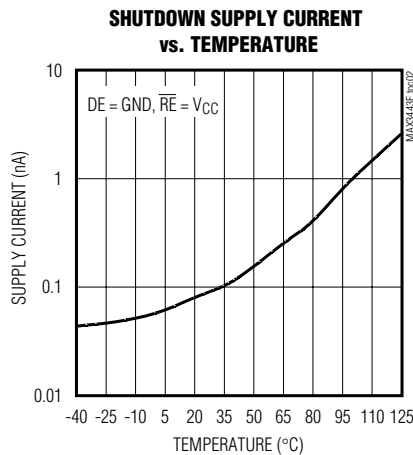
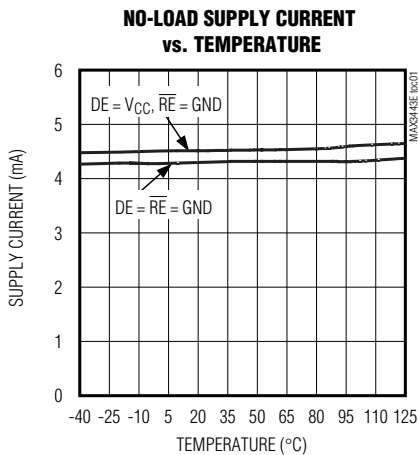

±60V Fault-Protected, 10Mbps, Fail-Safe RS-485 Transceiver with ±15kV ESD Protection

Typical Operating Characteristics (continued)

(V_{CC} = +5V, T_A = +25°C, unless otherwise noted.)

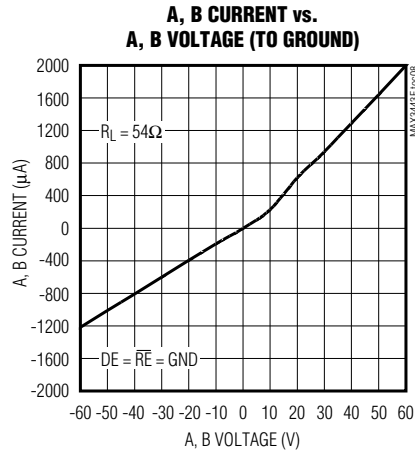
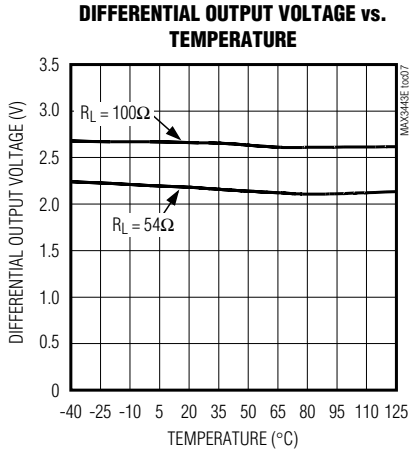
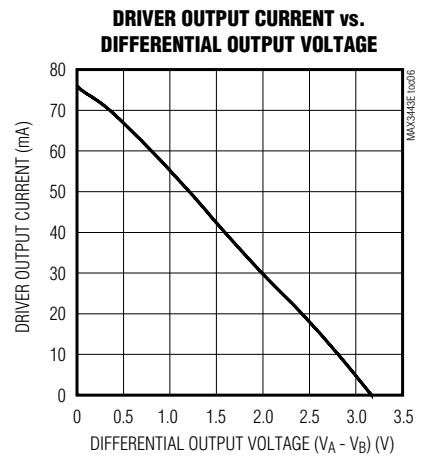
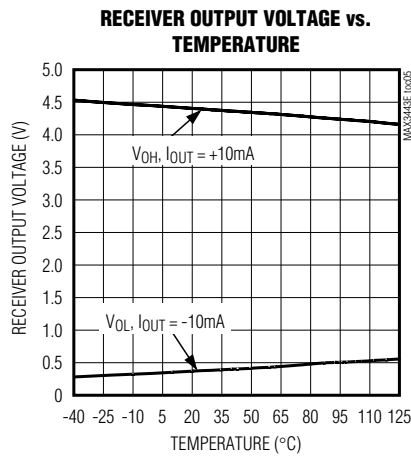
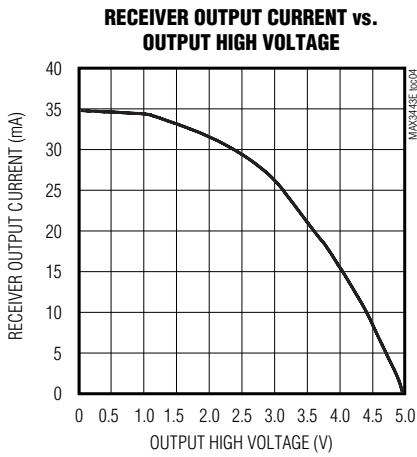

±60V Fault-Protected, 10Mbps, Fail-Safe RS-485 Transceiver with ±15kV ESD Protection

Test Circuits and Waveforms

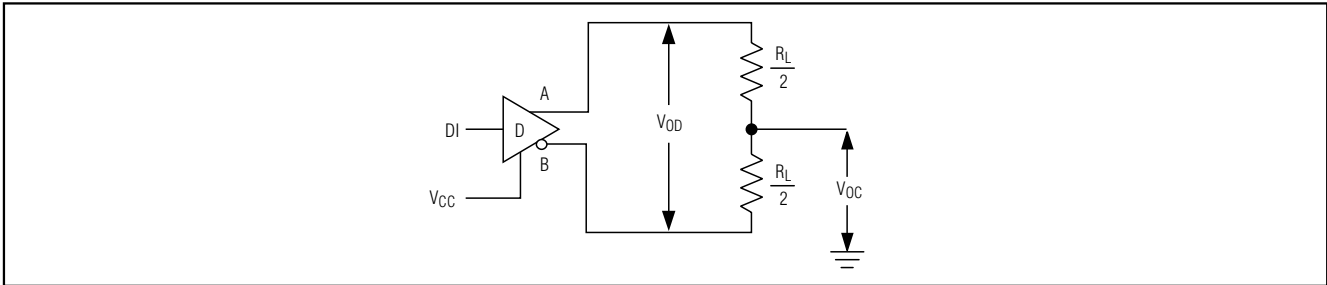

Figure 1. Driver V_{OD} and V_{CC}

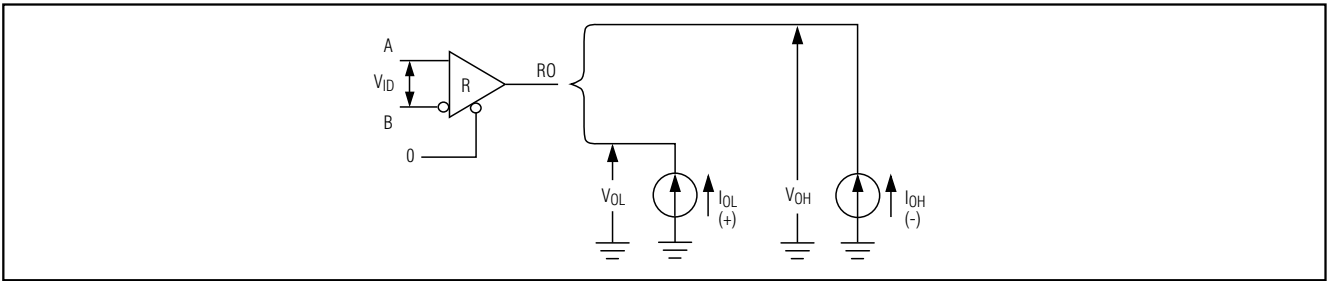

Figure 2. Receiver V_{OH} and V_{OL}

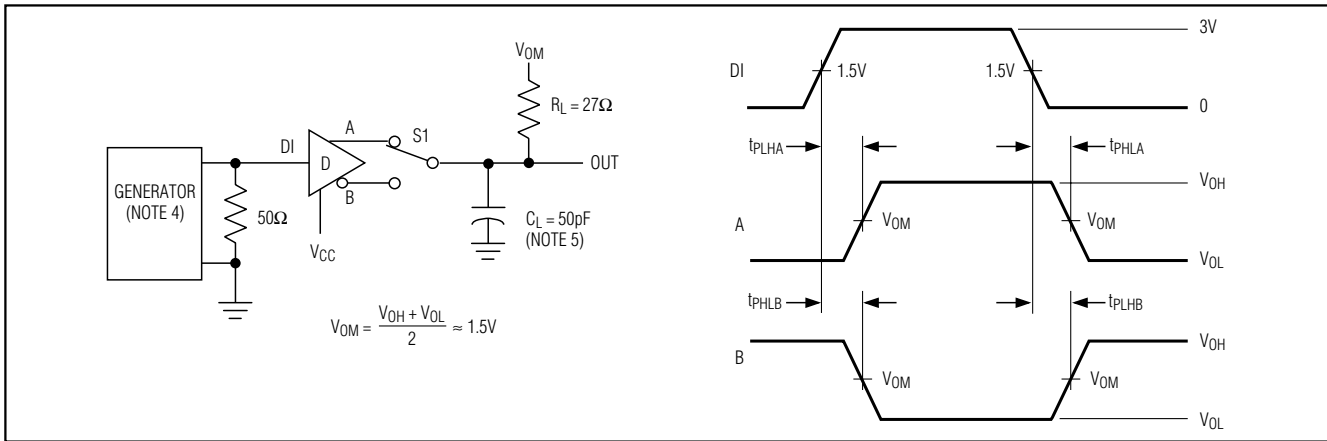

Figure 3. Driver Propagation Times

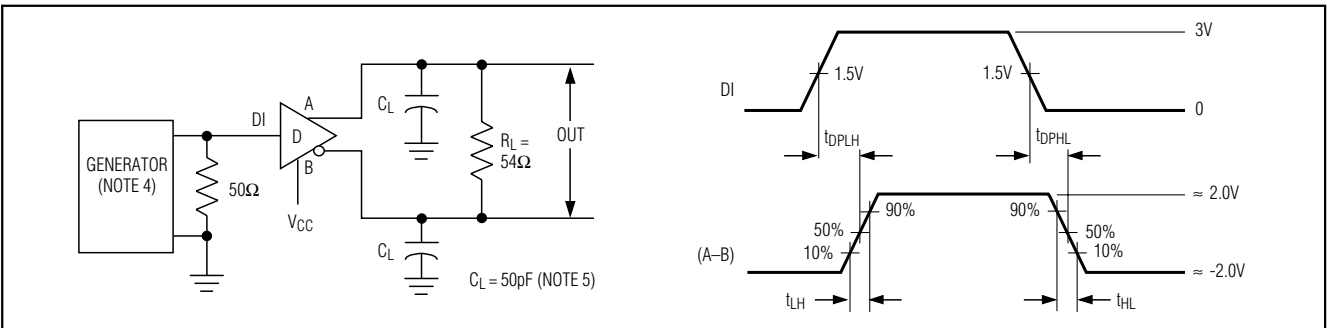

Figure 4. Driver Differential Output Delay and Transition Times

±60V Fault-Protected, 10Mbps, Fail-Safe RS-485 Transceiver with ±15kV ESD Protection

Test Circuits and Waveforms (continued)

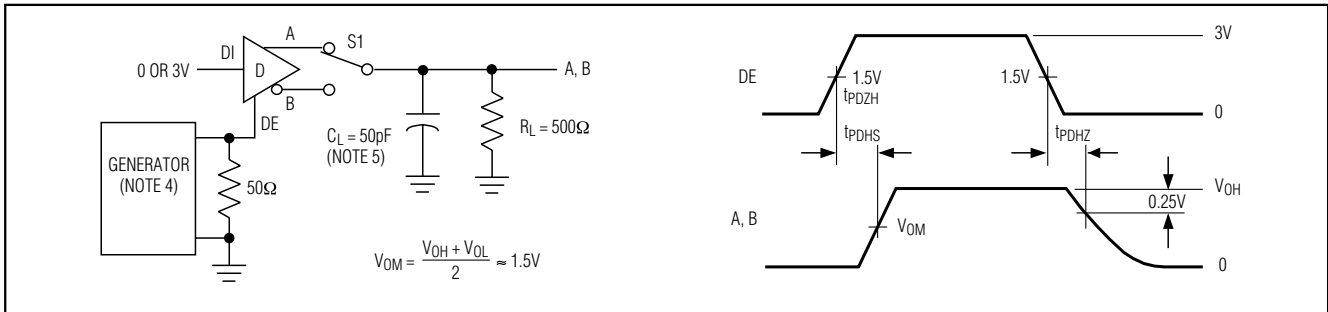

Figure 5. Driver Enable and Disable Times

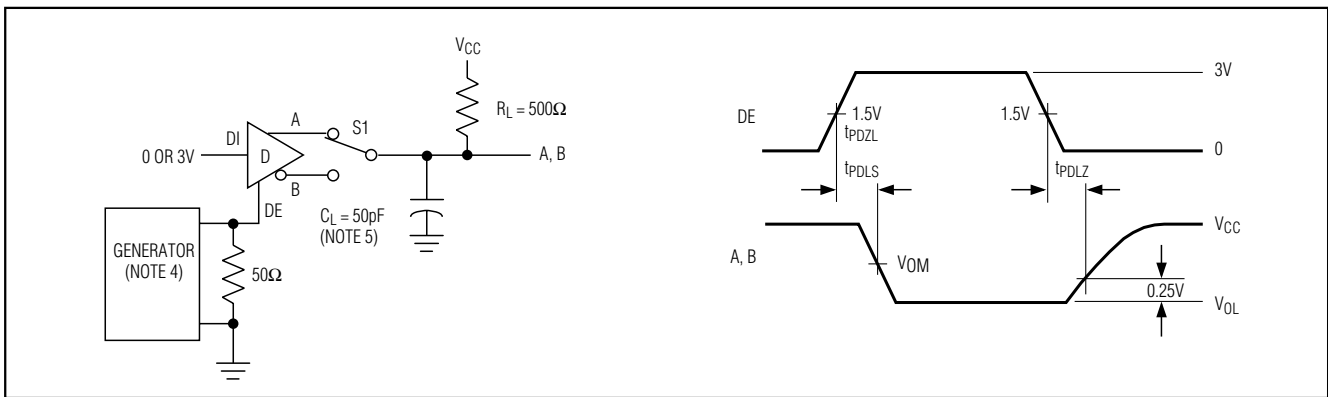

Figure 6. Driver Enable and Disable Times

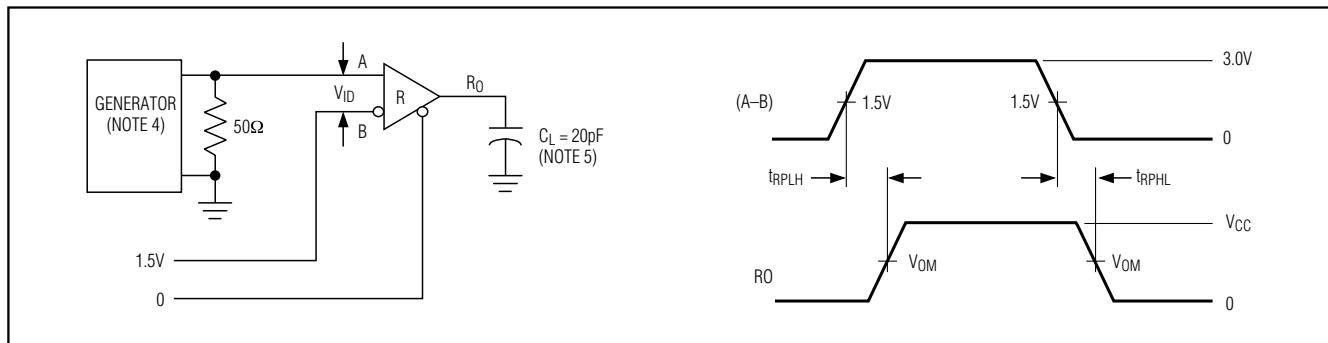

Figure 7. Receiver Propagation Delay

±60V Fault-Protected, 10Mbps, Fail-Safe RS-485 Transceiver with ±15kV ESD Protection

Test Circuits and Waveforms (continued)

MAX3443E

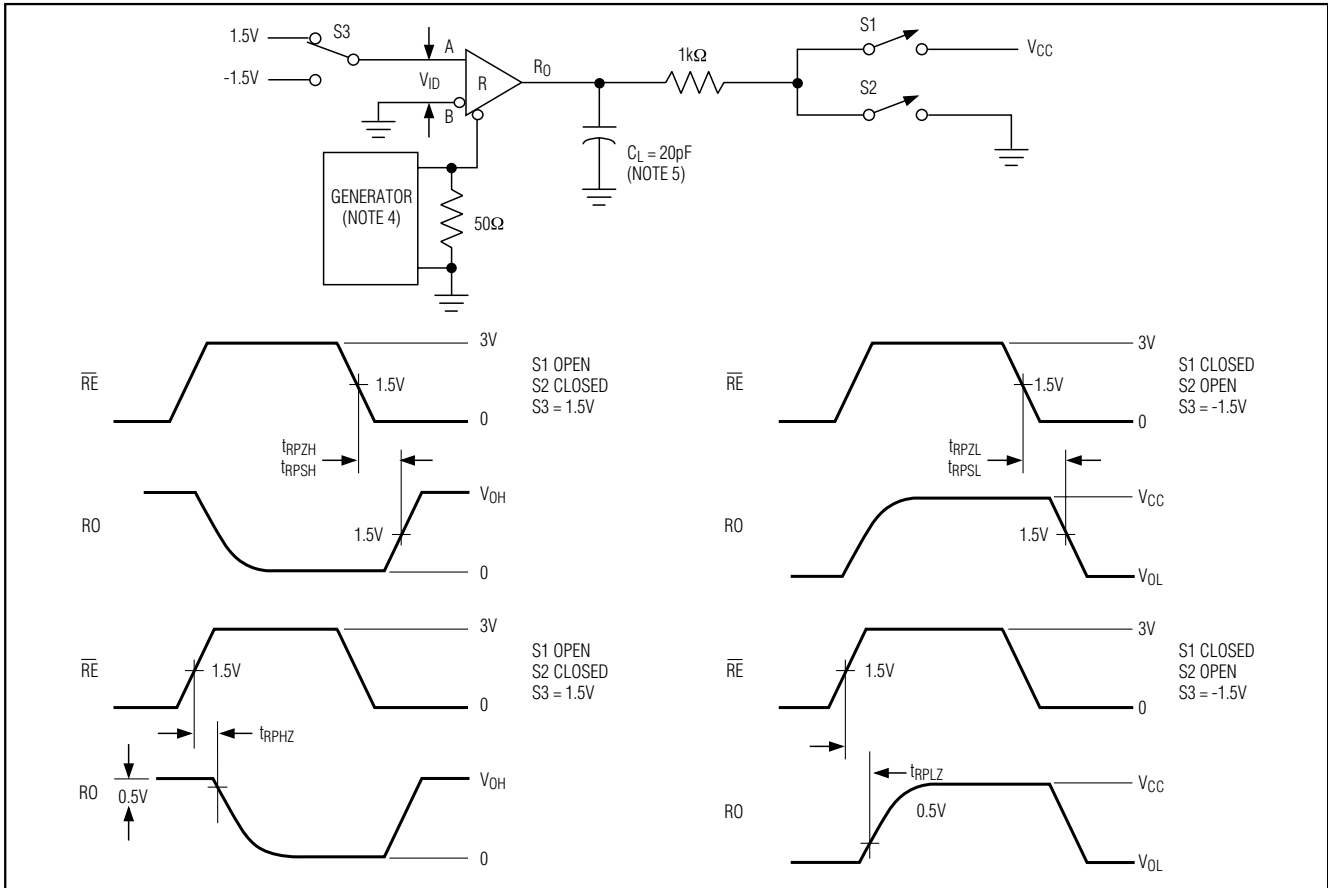

Figure 8. Receiver Enable and Disable Times

Note 4: The input pulse is supplied by a generator with the following characteristics: $f = 5\text{MHz}$, 50% duty cycle; $t_r \leq 6\text{ns}$; $Z_0 = 50\Omega$.

Note 5: C_L includes probe and stray capacitance.

Pin Description

PIN	NAME	FUNCTION
1	RO	Receiver Output. If $\overline{\text{RE}} = \text{low}$ and $(\text{A}-\text{B}) \geq -50\text{mV}$, $\text{RO} = \text{high}$; if $(\text{A}-\text{B}) \leq -200\text{mV}$, $\text{RO} = \text{low}$.
2	$\overline{\text{RE}}$	Receiver Output Enable. Pull $\overline{\text{RE}}$ low to enable RO.
3	DE	Driver Output Enable. Force DE high to enable driver. Pull $\overline{\text{DE}}$ low to three-state the driver output. Drive $\overline{\text{RE}}$ high and pull DE low to enter low-power shutdown mode.
4	DI	Driver Input. A logic low on DI forces the noninverting output low and the inverting output high. A logic high on DI forces the noninverting output high and the inverting output low.
5	GND	Ground
6	A	Noninverting Receiver Input/Driver Output with Integrated ±15kV ESD Protection
7	B	Inverting Receiver Input/Driver Output with Integrated ±15kV ESD Protection
8	VCC	Positive Supply, $V_{CC} = +4.75\text{V}$ to $+5.25\text{V}$

±60V Fault-Protected, 10Mbps, Fail-Safe RS-485 Transceiver with ±15kV ESD Protection

Function Tables

MAX3443E (RS-485/RS-422)

TRANSMITTING				
INPUTS			OUTPUTS	
\overline{RE}	DE	DI	A	B
0	0	X	High-Z	High-Z
0	1	0	0	1
0	1	1	1	0
1	0	X	Shutdown	Shutdown
1	1	0	0	1
1	1	1	1	0

X = Don't care.

MAX3443E (RS-485/RS-422)

RECEIVING			
INPUTS			OUTPUT
\overline{RE}	DE	(A-B)	RO
0	X	$\geq 0.2V$	1
0	X	$\leq -0.2V$	0
0	X	Open/Shorted	1
1	1	X	High-Z
1	0	X	Shutdown

X = Don't care.

Detailed Description

Driver

The driver accepts a single-ended, logic-level input (DI) and transfers it to a differential, RS-485/RS-422 level output (A and B). Driving DE high enables the driver, while pulling DE low places the driver outputs (A and B) into a high-impedance state (see the transmitting function table).

Receiver

The receiver accepts a differential, RS-485/RS-422 level input (A and B), and transfers it to a single-ended, logic-level output (RO). Pulling \overline{RE} low enables the receiver, while driving \overline{RE} high places the receiver inputs (A and B) into a high-impedance state (see the receiving function table).

Low-Power Shutdown

Force DE low and \overline{RE} high to shut down the MAX3443E. A time delay of 50ns prevents the device from accidentally entering shutdown due to logic skews when switching between transmit and receive modes. Holding DE low and \overline{RE} high for at least 800ns guarantees that the MAX3443E enters shutdown. In shutdown, the device consumes a maximum of 10 μ A supply current.

±60V Fault Protection

The driver outputs/receiver inputs of RS-485 devices in industrial network applications often experience voltage faults resulting from shorts to the power bus that exceed the -7V to +12V range specified in the EIA/TIA-485 standard. In these applications, ordinary RS-485 devices (typical absolute maximum -8V to +12.5V) require costly external protection devices. To reduce system complexity and eliminate this need for external protection, the driver outputs/receiver inputs of the MAX3443E withstand voltage faults up to ±60V with

respect to ground without damage. Protection is guaranteed regardless of whether the device is active, shut down, or without power.

True Fail-Safe

The MAX3443E uses a -50mV to -200mV differential input threshold to ensure true fail-safe receiver inputs. This threshold guarantees the receiver output is a logic high for shorted, open, or idle data lines. The -50mV to -200mV threshold complies with the ±200mV threshold specified in the EIA/TIA-485 standard.

±15kV ESD Protection

As with all Maxim devices, ESD-protection structures are incorporated on all pins to protect against ESD encountered during handling and assembly. The MAX3443E receiver inputs/driver outputs (A, B) have extra protection against static electricity found in normal operation. Maxim's engineers developed state-of-the-art structures to protect these pins against ±15kV ESD without damage. After an ESD event, the MAX3443E continues working without latchup.

ESD protection can be tested in several ways. The receiver inputs are characterized for protection to the following:

- ±15kV using the Human Body Model
- ±8kV using the Contact Discharge method specified in IEC 1000-4-2 (formerly IEC 801-2)
- ±15kV using the Air-Gap Discharge method specified in IEC 1000-4-2 (formerly IEC 801-2)

ESD Test Conditions

ESD performance depends on a number of conditions. Contact Maxim for a reliability report that documents test setup, methodology, and results.

±60V Fault-Protected, 10Mbps, Fail-Safe RS-485 Transceiver with ±15kV ESD Protection

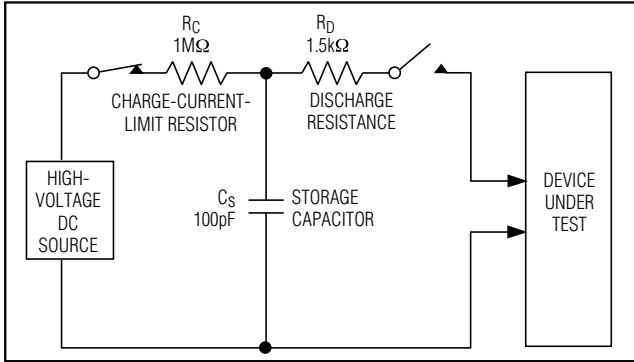

Figure 9a. Human Body ESD Test Model

Human Body Model

Figure 9a shows the Human Body Model, and Figure 9b shows the current waveform it generates when discharged into a low impedance. This model consists of a 100pF capacitor charged to the ESD voltage of interest, which is then discharged into the device through a 1.5kΩ resistor.

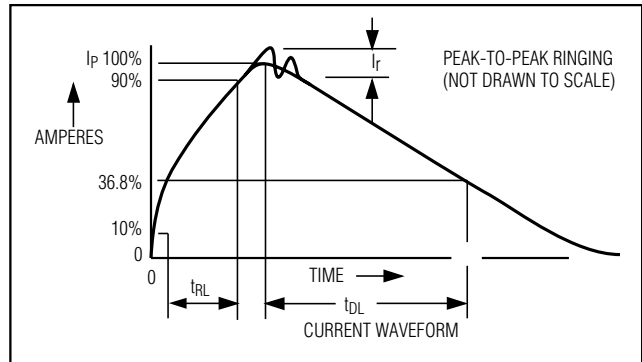

Figure 9b. Human Body Model Current Waveform

IEC 1000-4-2

Since January 1996, all equipment manufactured and/or sold in the European community has been required to meet the stringent IEC 1000-4-2 specification. The IEC 1000-4-2 standard covers ESD testing and performance of finished equipment; it does not specifically refer to integrated circuits. The MAX3443E helps you design equipment that meets Level 4 (the highest level) of IEC 1000-4-2, without additional ESD-protection components.

The main difference between tests done using the Human Body Model and IEC 1000-4-2 is higher peak current in IEC 1000-4-2. Because series resistance is lower in the IEC 1000-4-2 ESD test model (Figure 10a), the ESD withstand voltage measured to this standard is generally lower than that measured using the Human

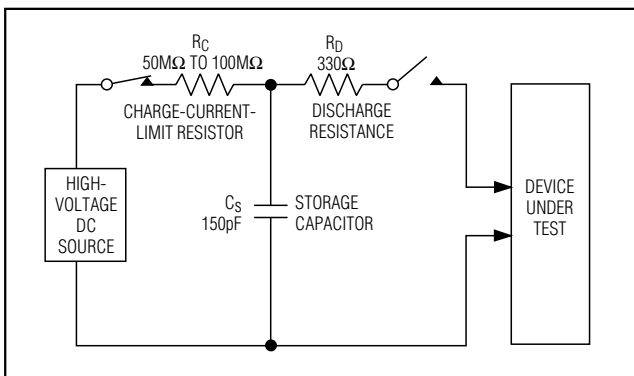

Figure 10a. IEC 1000-4-2 ESD Test Model

Body Model. Figure 10b shows the current waveform for the ±8kV IEC 1000-4-2 Level 4 ESD Contact Discharge test. The Air-Gap test involves approaching the device with a charge probe. The Contact Discharge method connects the probe to the device before the probe is energized.

Machine Model

The Machine Model for ESD testing uses a 200pF storage capacitor and zero-discharge resistance. It mimics the stress caused by handling during manufacturing and assembly. All pins (not just RS-485 inputs) require this protection during manufacturing. Therefore, the Machine Model is less relevant to the I/O ports than are the Human Body Model and IEC 1000-4-2.

Driver Output Protection

Two mechanisms prevent excessive output current and power dissipation caused by faults, or bus contention. The first, a foldback current limit on the driver output stage, provides immediate protection against short circuits over the whole common-mode voltage range. The second, a thermal shutdown circuit, forces the driver

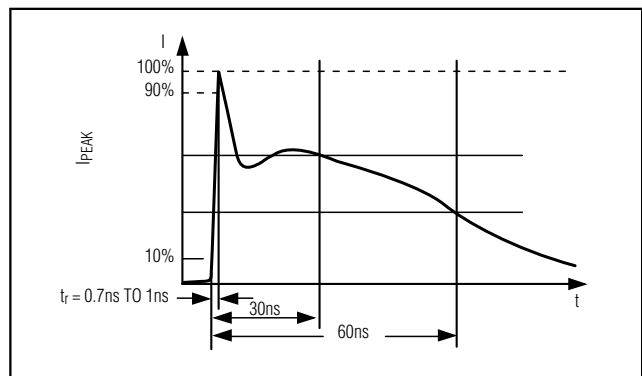

Figure 10b. IEC 1000-4-2 ESD Generator Current Waveform

±60V Fault-Protected, 10Mbps, Fail-Safe RS-485 Transceiver with ±15kV ESD Protection

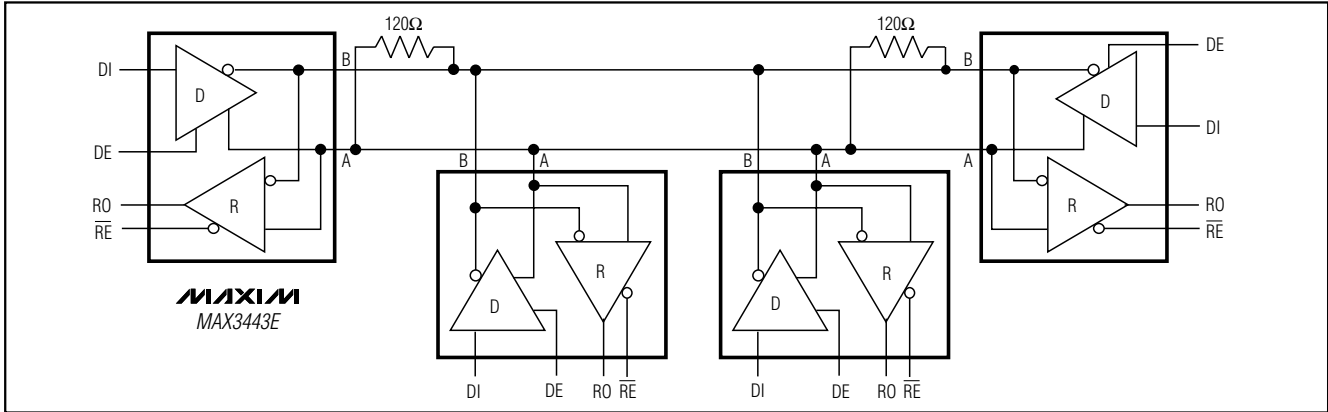

Figure 12. MAX3443E Typical RS-485 Network

all times. Incoming data on DE enables the driver, which pulls the line low and causes all receivers to output a logic low.

Chip Information

TRANSISTOR COUNT: 310
PROCESS: BiCMOS

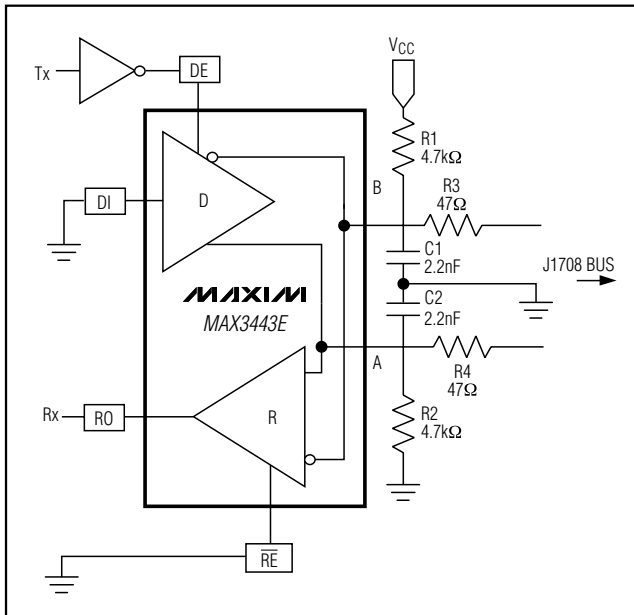
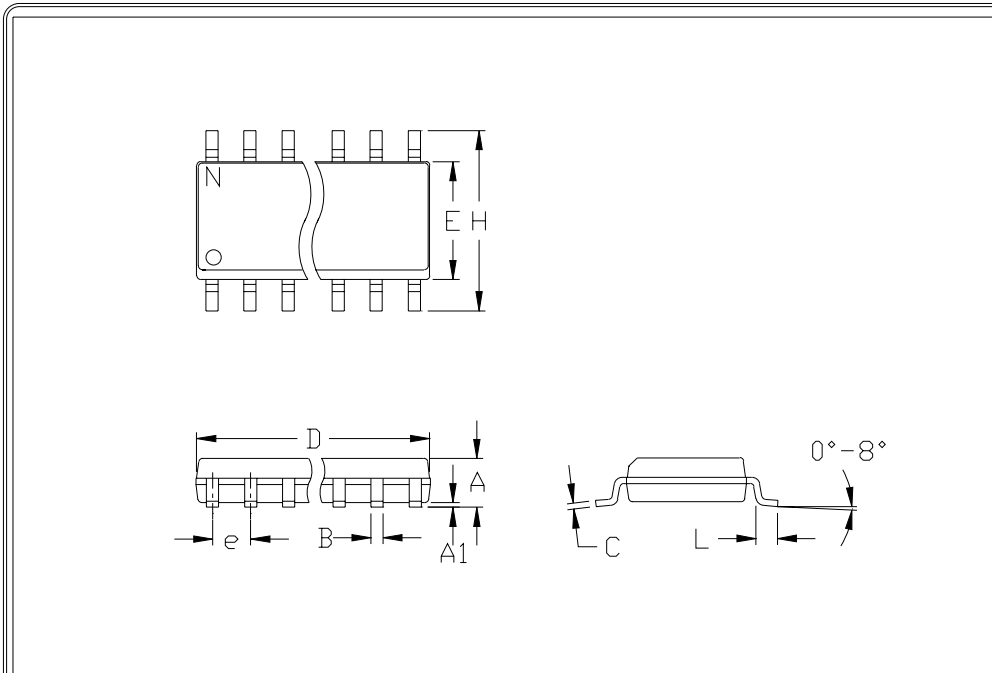

Figure 13. J1708 Application Circuit

±60V Fault-Protected, 10Mbps, Fail-Safe RS-485 Transceiver with ±15kV ESD Protection

Package Information

(The package drawing(s) in this data sheet may not reflect the most current specifications. For the latest package outline information, go to www.maxim-ic.com/packages.)



	INCHES		MILLIMETERS	
	MIN	MAX	MIN	MAX
A	0.053	0.069	1.35	1.75
A1	0.004	0.010	0.10	0.25
B	0.014	0.019	0.35	0.49
C	0.007	0.010	0.19	0.25
e	0.050		1.27	
E	0.150	0.157	3.80	4.00
H	0.228	0.244	5.80	6.20
h	0.010	0.020	0.25	0.50
L	0.016	0.050	0.40	1.27

	INCHES		MILLIMETERS		N	MS012
	MIN	MAX	MIN	MAX		
D	0.189	0.197	4.80	5.00	8	A
D	0.337	0.344	8.55	8.75	14	B
D	0.386	0.394	9.80	10.00	16	C

NOTES:

1. D&E DO NOT INCLUDE MOLD FLASH
2. MOLD FLASH OR PROTRUSIONS NOT TO EXCEED .15mm (.006")
3. LEADS TO BE COPLANAR WITHIN .102mm (.004")
4. CONTROLLING DIMENSION: MILLIMETER
5. MEETS JEDEC MS012-XX AS SHOWN IN ABOVE TABLE
6. N = NUMBER OF PINS

 <small>120 SAN GABRIEL DR. SAN JOSE, CA 94066 FAX (408) 737-7794</small> <small>PROPRIETARY INFORMATION</small>	PACKAGE FAMILY OUTLINE: SOIC .150"		21-0041 A
			<small>DOCUMENT CONTROL NUMBER REV</small>

±60V Fault-Protected, 10Mbps, Fail-Safe RS-485 Transceiver with ±15kV ESD Protection

Package Information (continued)

(The package drawing(s) in this data sheet may not reflect the most current specifications. For the latest package outline information, go to www.maxim-ic.com/packages.)

MAX3443E

PDIPN.EPS

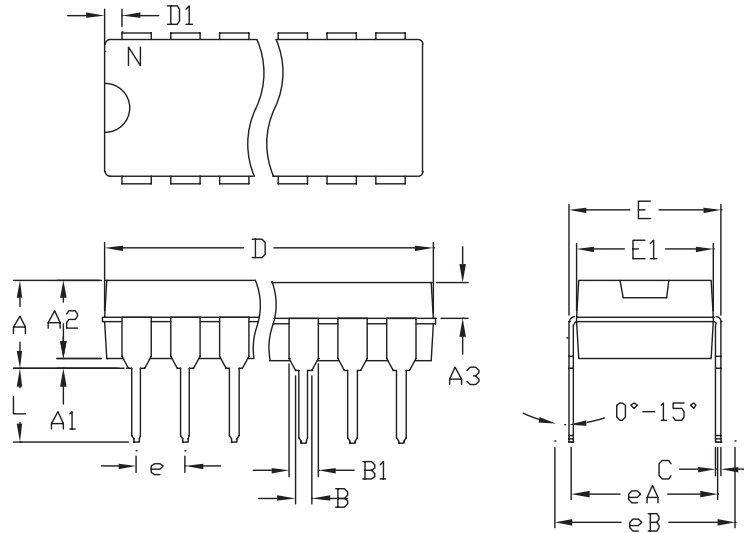

	INCHES		MILLIMETERS	
	MIN	MAX	MIN	MAX
A	---	0.180	---	4.572
A1	0.020	---	0.508	---
A2	0.125	0.175	3.18	4.45
A3	0.055	0.080	1.40	2.03
B	0.015	0.021	0.381	0.533
B1	0.045	0.060	1.14	1.524
C	0.009	0.014	0.229	0.355
D1	0.005	0.080	0.13	2.03
E	0.300	0.325	7.62	8.255
E1	0.275	0.295	6.985	7.493
e	0.100	---	2.54	---
eA	0.300	---	7.62	---
eB	---	0.400	---	10.16
L	0.115	0.150	2.921	3.81

	INCHES		MILLIMETERS		N	MS001
	MIN	MAX	MIN	MAX		
D	0.348	0.390	8.84	9.91	8	AB
D	0.735	0.765	18.67	19.43	14	AC
D	0.745	0.765	18.92	19.43	16	AA
D	0.885	0.915	22.48	23.24	18	AD
D	1.015	1.045	25.78	26.54	20	AE
D	1.14	1.265	28.96	32.13	24	AF
D	1.360	1.380	34.54	35.05	28	*5

NOTES:

1. D&E DO NOT INCLUDE MOLD FLASH
2. MOLD FLASH OR PROTRUSIONS NOT TO EXCEED .15mm (.006")
3. CONTROLLING DIMENSION: MILLIMETER
4. MEETS JEDEC MS001-XX AS SHOWN IN ABOVE TABLE
5. SIMILAR TO JEDEC MS-095-AH
6. N = NUMBER OF PINS

 <small>230 SAN GABRIEL, JR. SUNNYVALE, CA 94086 FAX (408) 737-7104</small> <small>PROPRIETARY INFORMATION</small>	PACKAGE FAMILY OUTLINE: PDIP .300"		21-0043 B

Maxim cannot assume responsibility for use of any circuitry other than circuitry entirely embodied in a Maxim product. No circuit patent licenses are implied. Maxim reserves the right to change the circuitry and specifications without notice at any time.

Maxim Integrated Products, 120 San Gabriel Drive, Sunnyvale, CA 94086 408-737-7600 _____ 15