

MAXIM

VHF-to-Microwave, +3V, General-Purpose Amplifiers

MAX2630-MAX2633

General Description

The MAX2630/MAX2631/MAX2632/MAX2633 are low-voltage, low-noise amplifiers for use from VHF to microwave frequencies. Operating from a single +2.7V to +5.5V supply, these devices have a flat gain response to 900MHz. Their low noise figure and low supply current make them ideal for receive, buffer, and transmit IF applications.

The MAX2630/MAX2631 are biased internally, eliminating the need for external bias resistors or inductors. The MAX2632/MAX2633 have a user-selectable supply current, which can be adjusted by adding a single external resistor. This allows customized output power and gain according to specific applications requirements. The MAX2631/MAX2633 feature a shutdown pin that allows them to be powered down to less than 1µA supply current. Aside from a single bias resistor required for the MAX2632/MAX2633, the only external components needed for this family of amplifiers are input and output blocking capacitors and a VCC bypass capacitor.

The MAX2630 comes in a 4-pin SOT143 package, requiring minimal board space. The MAX2631/MAX2632 come in small 5-pin SOT23 packages. The MAX2633 comes in a 6-pin SOT23 package.

Applications

- | | |
|--------------------------------|-----------------|
| Personal Communicating Systems | Cordless Phones |
| Global Positioning Systems | Cellular Phones |
| Wireless Local Area Networks | ISM Radios |
| Wireless Local Loops | TV Tuners |
| Land Mobile Radios | Set-Top Boxes |

Typical Operating Circuit

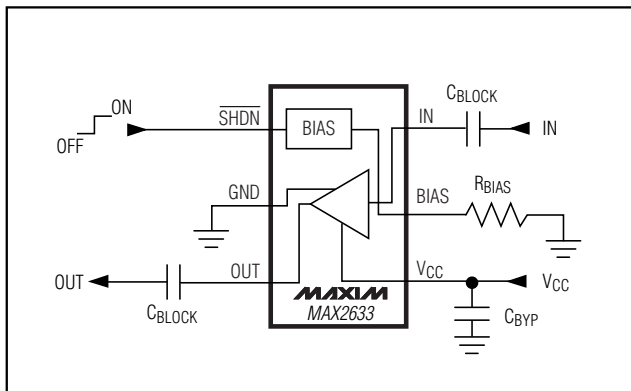

Features

- ◆ Single +2.7V to +5.5V Operation
- ◆ Internally Biased (MAX2630/MAX2631)
- ◆ Adjustable Bias (MAX2632/MAX2633)
- ◆ 6.6mA Supply Current (insensitive to supply voltage)
- ◆ 1µA Shutdown Current (MAX2631/MAX2633)
- ◆ 3.7dB Noise Figure
- ◆ 13.4dB Gain
- ◆ Ultra-Small SOT Packages

Ordering Information

PART	TEMP RANGE	PIN-PACKAGE	SOT TOP MARK*
MAX2630EUS-T	-40°C to +85°C	4 SOT143-4	DG__
MAX2631EUK-T	-40°C to +85°C	5 SOT23-5	AABK
MAX2632EUK-T	-40°C to +85°C	5 SOT23-5	AABL
MAX2633EUT-T	-40°C to +85°C	6 SOT23-6	AAAA

*The first two letters in the SOT top mark identify the part, while the remaining two letters are the lot-tracking code.

Pin Configurations

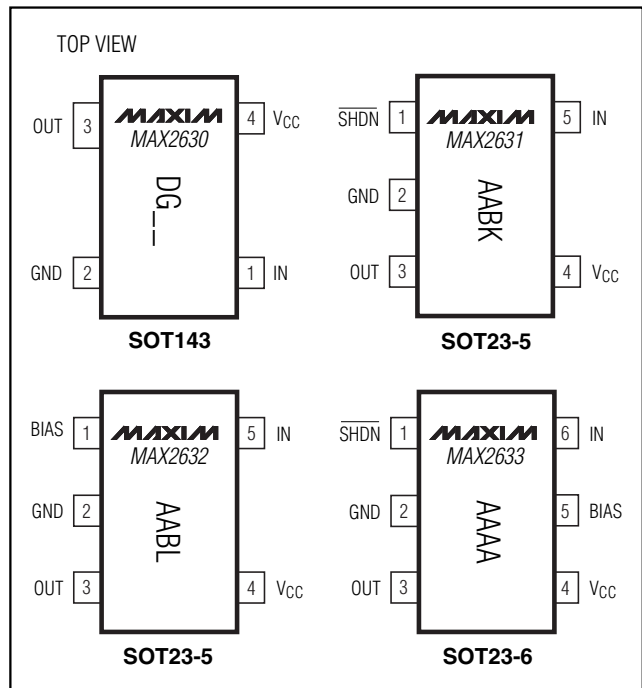

VHF-to-Microwave, +3V, General-Purpose Amplifiers

ABSOLUTE MAXIMUM RATINGS

V _{CC} to GND	-0.3V to 6V	Continuous Power Dissipation (T _A = +70°C)	
Input Power	5dBm	SOT143 (derate 4mW/°C above +70°C).....	320mW
OUT Current	±12mA	SOT23-5 (derate 7.1mW/°C above +70°C).....	571mW
IN to GND Voltage	-1.2V to 1.2V	SOT23-6 (derate 7.1mW/°C above +70°C).....	571mW
Bias to GND Voltage	0.0V to 3V	Operating Temperature Range	-40°C to +85°C
Voltage at SHDN Input		Junction Temperature	+150°C
(MAX2631/MAX2633)	-0.3V to (V _{CC} + 0.3V)	Storage Temperature Range	-65°C to +150°C
Current into SHDN Input (MAX2631/MAX2633).....	100µA	Lead Temperature (soldering, 10s)	+300°C

Stresses beyond those listed under "Absolute Maximum Ratings" may cause permanent damage to the device. These are stress ratings only, and functional operation of the device at these or any other conditions beyond those indicated in the operational sections of the specifications is not implied. Exposure to absolute maximum rating conditions for extended periods may affect device reliability.

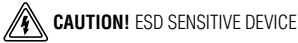

ELECTRICAL CHARACTERISTICS

(V_{CC} = +3V, Z₀ = 50Ω, f_{IN} = 900MHz, R_{BIAS} = 10kΩ (MAX2632/MAX2633), V_{SHDN} = V_{CC} (MAX2631/MAX2633), T_A = +25°C, unless otherwise noted.)

PARAMETERS	CONDITIONS	MIN	TYP	MAX	UNITS	
Operating Temperature Range	(Note 1)	-40		85	degrees	
Supply Voltage		2.7		5.5	V	
Power Gain	T _A = +25°C	11	13.4	16.5	dB	
	T _A = T _{MIN} to T _{MAX} (Note 1)	9.4		18.4		
Noise Figure			3.8		dB	
Output 1dB Compression Point			-11		dBm	
Output IP3			-1		dBm	
Input Voltage Standing-Wave Ratio	f _{IN} = 800MHz to 1000MHz		1.3:1			
Output Voltage Standing-Wave Ratio	f _{IN} = 800MHz to 1000MHz		1.25:1			
Supply Current	R _{BIAS} = 40kΩ		1.3	1.5	mA	
	R _{BIAS} = 10kΩ	V _{CC} = 3V, T _A = +25°C	5.5	6.5		8.0
		V _{CC} = 3V, T _A = T _{MIN} to T _{MAX} (Note1)	4.2	6.5		9.2
		V _{CC} = 2.7V to 5.5V, T _A = +25°C	5.2	6.5		11.0
	R _{BIAS} = 500Ω	15	17			
Shutdown Supply Current	MAX2631/MAX2633		<0.1	1	µA	
SHDN Input Low Voltage	MAX2631/MAX2633, V _{CC} = 2.7V to 5.5V			0.45	V	
SHDN Input High Voltage	MAX2631/MAX2633, V _{CC} = 2.7V to 5.5V	2.0			V	
SHDN Input Bias Current	MAX2631/ MAX2633	V _{SHDN} = V _{CC}		30	µA	
		V _{SHDN} = GND		1		

Note 1: Guaranteed by design and characterization.

VHF-to-Microwave, +3V, General-Purpose Amplifiers

Typical Operating Characteristics

($V_{CC} = +3V$, $V_{SHDN} = V_{CC}$ (MAX2631/MAX2633), $Z_0 = 50\Omega$, $f_{IN} = 900MHz$, $R_{BIAS} = 10k\Omega$ (MAX2632/MAX2633), $T_A = +25^\circ C$, unless otherwise noted.)

MAX2630-MAX2633

SUPPLY CURRENT vs. SUPPLY VOLTAGE

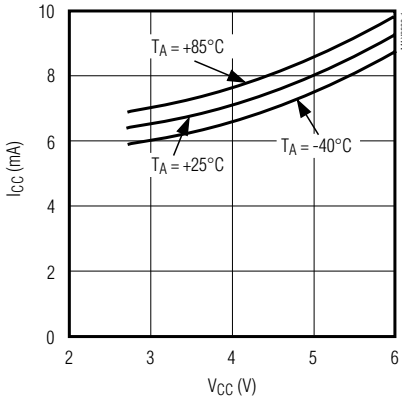

**MAX2632/MAX2633
GAIN vs. SUPPLY CURRENT**

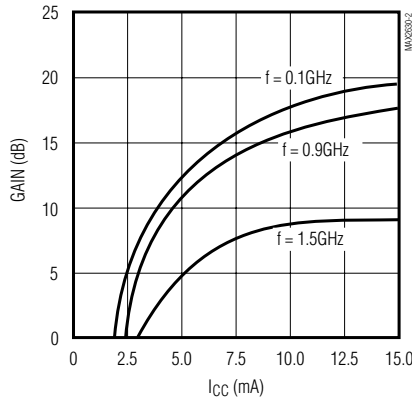

GAIN vs. FREQUENCY AND VOLTAGE

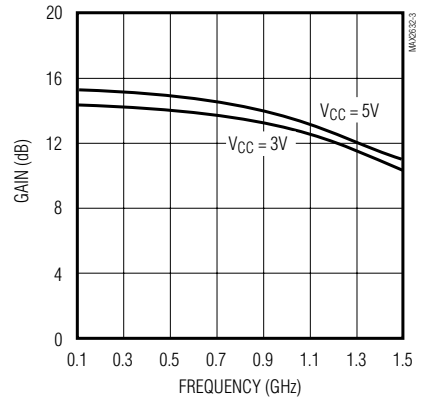

**GAIN vs. FREQUENCY
AND TEMPERATURE**

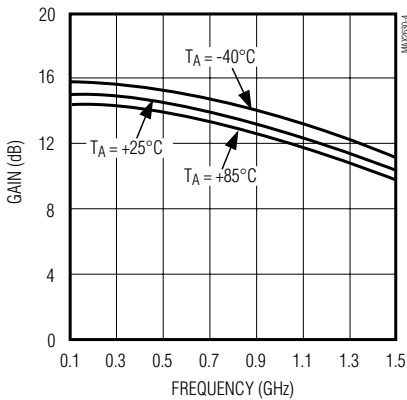

**OUTPUT 1dB COMPRESSION
POWER vs. FREQUENCY AND VOLTAGE**

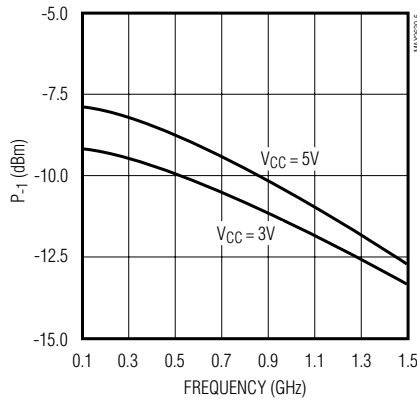

**OUTPUT 1dB COMPRESSION
POWER vs. FREQUENCY AND TEMPERATURE**

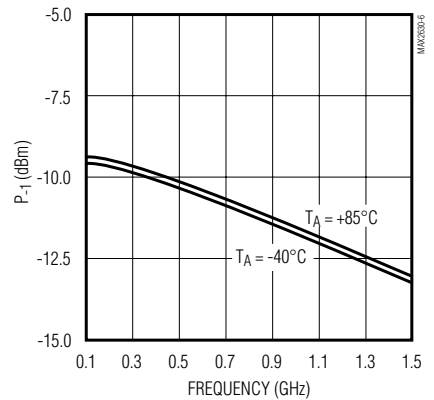

**MAX2632/MAX2633
OUTPUT 1dB COMPRESSION
POWER vs. SUPPLY CURRENT**

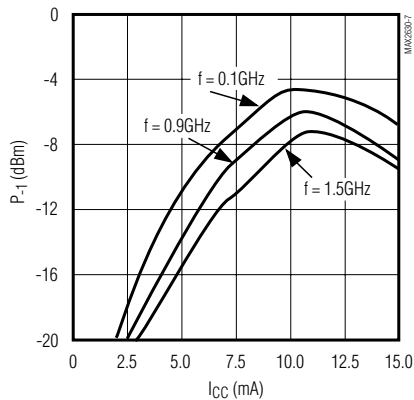

NOISE FIGURE vs. FREQUENCY

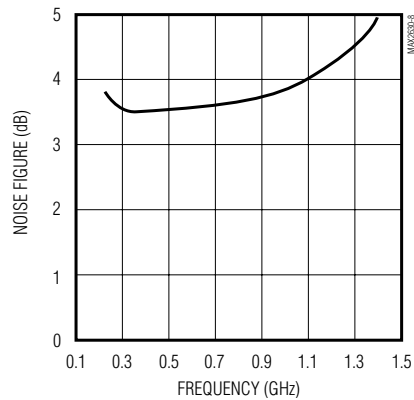

VHF-to-Microwave, +3V, General-Purpose Amplifiers

Typical Operating Characteristics (continued)

($V_{CC} = +3V$, $V_{\overline{SHDN}} = V_{CC}$ (MAX2631/MAX2633), $Z_0 = 50\Omega$, $f_{IN} = 900MHz$, $R_{BIAS} = 10k\Omega$ (MAX2632/MAX2633), $T_A = +25^\circ C$, unless otherwise noted.)

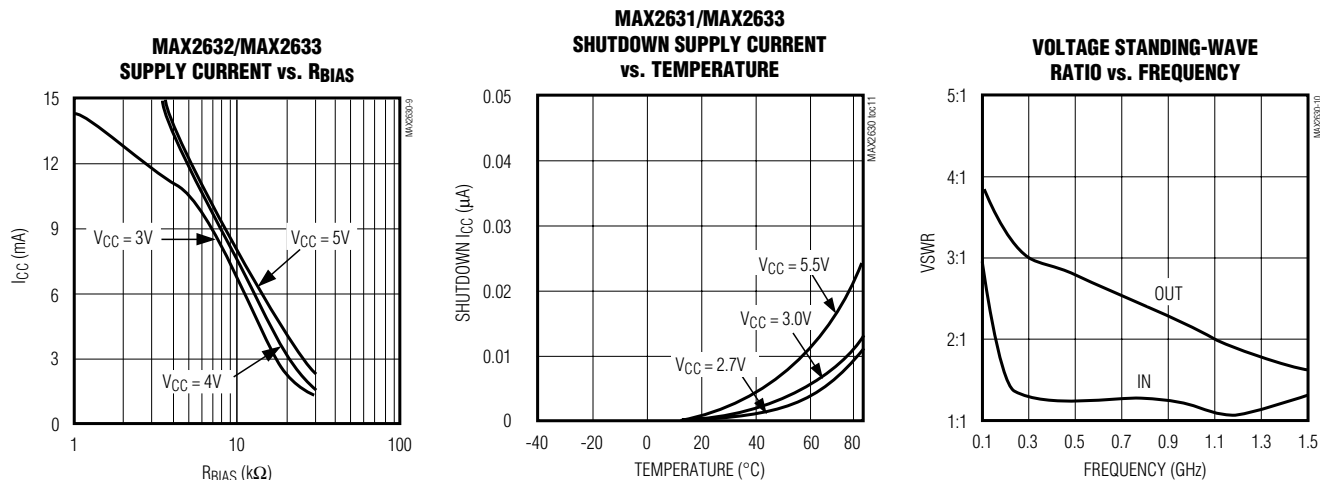

Pin Description

PIN				NAME	FUNCTION
MAX2630	MAX2631	MAX2632	MAX2633		
1	5	5	6	IN	Amplifier Input. Use a series blocking capacitor with less than 3Ω reactance at your lowest operating frequency.
2	2	2	2	GND	Ground Connection. For optimum performance, provide a low-inductance connection to the ground plane.
3	3	3	3	OUT	Amplifier Output. Use a series blocking capacitor with less than 3Ω reactance at your lowest operating frequency.
4	4	4	4	V_{CC}	Supply Connection. Bypass directly at the supply pin. The value of the bypass capacitor is determined by the lowest operating frequency, and is typically the same as the blocking capacitor value. Additional bypassing may be necessary for long V_{CC} lines.
—	1	—	1	\overline{SHDN}	Shutdown Input. Driving \overline{SHDN} with a logic low turns off the amplifier.
—	—	1	5	BIAS	Bias Resistor Connection. Connect a resistor to GND to set the bias current. See the Supply Current vs. R_{BIAS} graph in the <i>Typical Operating Characteristics</i> .

VHF-to-Microwave, +3V, General-Purpose Amplifiers

MAX2630-MAX2633

Table 1a. Typical Scattering Parameters

($V_{CC} = +3V$, $V_{SHDN} = V_{CC}$, $Z_0 = 50\Omega$, $R_{BIAS} = 10k\Omega$, $T_A = +25^\circ C$.)

FREQUENCY (GHz)	S11 (mag)	S11 (ang)	S21 (dB)	S21 (mag)	S21 (ang)	S12 (dB)	S12 (mag)	S12 (ang)	S22 (mag)	S22 (ang)	K
0.05	0.59	-50	12.9	4.39	46	-38.7	0.012	37	0.62	-19	4.30
0.10	0.37	-70	14.2	5.11	1	-36.7	0.015	12	0.57	-29	4.07
0.20	0.22	-86	14.5	5.32	-49	-35.8	0.016	-13	0.54	-49	3.93
0.30	0.17	-100	14.5	5.32	-89	-35.0	0.018	-32	0.53	-71	3.74
0.40	0.16	-109	14.5	5.28	-125	-34.4	0.019	-51	0.51	-94	3.61
0.50	0.15	-99	14.3	5.19	-138	-33.6	0.021	-70	0.50	-118	3.45
0.60	0.14	-86	14.1	5.05	-127	-33.0	0.022	-89	0.48	-109	3.38
0.70	0.14	-68	13.9	4.93	-116	-32.2	0.025	-107	0.46	-96	3.27
0.80	0.14	-49	13.5	4.75	-104	-31.3	0.027	-124	0.44	-82	3.16
0.90	0.13	-31	13.0	4.49	-93	-30.3	0.031	-142	0.42	-68	3.05
1.00	0.13	-10	12.6	4.25	-82	-29.0	0.035	-161	0.40	-53	2.87
1.20	0.06	19	10.8	3.48	-58	-25.8	0.051	153	0.33	-25	2.59
1.40	0.11	-60	7.9	2.48	-110	-23.7	0.065	113	0.26	-12	2.90
1.60	0.24	-31	5.6	1.91	-162	-23.6	0.066	122	0.26	-7	3.51
1.80	0.30	-26	4.8	1.73	144	-23.7	0.065	120	0.26	-34	3.76
2.00	0.31	-66	4.3	1.63	86	-23.3	0.069	117	0.25	-63	3.80
2.20	0.27	-98	3.6	1.51	27	-22.3	0.077	116	0.24	-83	3.80
2.40	0.24	-115	2.6	1.36	5	-21.3	0.086	116	0.25	-97	3.81
2.50	0.22	-120	2.2	1.29	12	-21.0	0.089	114	0.27	-106	3.86

VHF-to-Microwave, +3V, General-Purpose Amplifiers

Table 1b. MAX2633 Typical Scattering Parameters

 (V_{CC} = +5V, V_{SHDN} = V_{CC}, Z₀ = 50Ω, R_{BIAS} = 10k, T_A = +25°C.)

FREQUENCY (GHz)	S11 (mag)	S11 (ang)	S21 (dB)	S21 (mag)	S21 (ang)	S12 (dB)	S12 (mag)	S12 (ang)	S22 (mag)	S22 (ang)	K
0.05	0.58	-53	13.6	4.80	45	-39.2	0.011	36	0.62	-22	4.26
0.10	0.35	-76	15.0	5.62	1	-36.9	0.014	13	0.57	-29	3.83
0.20	0.20	-97	15.4	5.87	-48	-36.1	0.016	-14	0.55	-49	3.75
0.30	0.14	-101	15.4	5.91	-87	-35.2	0.017	-31	0.53	-72	3.48
0.40	0.12	-94	15.4	5.91	-123	-34.7	0.018	-50	0.52	-95	3.35
0.50	0.11	-82	15.4	5.87	-141	-33.8	0.020	-68	0.51	-119	3.14
0.60	0.11	-66	15.2	5.78	-130	-33.1	0.022	-86	0.49	-108	3.02
0.70	0.11	-45	15.1	5.68	-119	-32.3	0.024	-104	0.48	-94	2.87
0.80	0.11	-22	14.9	5.54	-108	-31.3	0.027	-121	0.45	-79	2.73
0.90	0.12	-2	14.5	5.30	-96	-30.0	0.032	-139	0.43	-65	2.51
1.00	0.12	21	14.1	5.09	-85	-28.5	0.038	-158	0.42	-49	2.28
1.20	0.08	-54	12.5	4.22	-59	-25.2	0.055	153	0.34	-18	2.01
1.40	0.10	-103	9.3	2.93	-112	-23.1	0.070	114	0.24	-4	2.36
1.60	0.22	-44	6.7	2.16	-163	-23.3	0.068	125	0.24	-7	3.07
1.80	0.29	-20	5.8	1.96	145	-23.7	0.065	124	0.24	-37	3.41
2.00	0.30	-60	5.3	1.85	89	-23.3	0.069	120	0.23	-65	3.41
2.20	0.26	-92	4.9	1.75	29	-22.2	0.078	117	0.21	-83	3.31
2.40	0.24	-110	3.9	1.57	2	-21.7	0.082	116	0.23	-95	3.48
2.50	0.23	-113	3.5	1.50	10	-20.9	0.090	115	0.25	-100	3.35

VHF-to-Microwave, +3V, General-Purpose Amplifiers

Detailed Description

The MAX2630-MAX2633 are broadband amplifiers with 3dB bandwidth greater than 1GHz. Their small size and internal bias circuitry make them ideal for applications where board space is limited. The MAX2632/MAX2633 have a user-selectable bias current that allows the user to set both gain and output power for a particular application, and the MAX2631/MAX2633 incorporate shut-down capability.

Applications Information

External Components

The MAX2630-MAX2633 are easy to use, as shown in the *Typical Operating Circuit* and Figures 1, 2 and 3. Input and output series capacitors may be necessary to block DC bias voltages generated by the amplifiers from interacting with adjacent circuitry. These capacitors must be large enough to contribute negligible reactance in a 50Ω system at the minimum operating frequency. Use the following equation to calculate their minimum value:

$$C_{\text{BLOCK}} = \frac{53,000}{f} \text{ (pF)}$$

where f (in megahertz) is the minimum operating frequency.

The V_{CC} pin must be RF bypassed for correct operation. To accomplish this, connect a capacitor between the V_{CC} pin and ground, as close to the package as is practical. Use the same equation given above (for DC-blocking capacitor values) to calculate the minimum capacitor value. If the PC board has long V_{CC} lines, additional bypassing may be necessary. This can be done farther away from the package, if needed.

Proper grounding of the GND pin is essential. If the PC board uses a topside RF ground, connect it directly to the GND pin. For a board where the ground plane is not on the component side, the best technique is to connect the GND pin to it with a plated through-hole close to the package.

An on-chip buffer at the MAX2631/MAX2633's $\overline{\text{SHDN}}$ pin makes bypassing this pin unnecessary except in very noisy applications. When RF filtering is needed, use a bypass capacitor similar to the one used on V_{CC} . Since negligible current flows into this pin, additional RF filtering may be done with a series resistor.

To set the MAX2632/MAX2633's supply current, connect a resistor from the BIAS pin to ground. To estimate the value of this resistor, refer to the graph Supply Current vs. R_{BIAS} in the *Typical Operating Characteristics*.

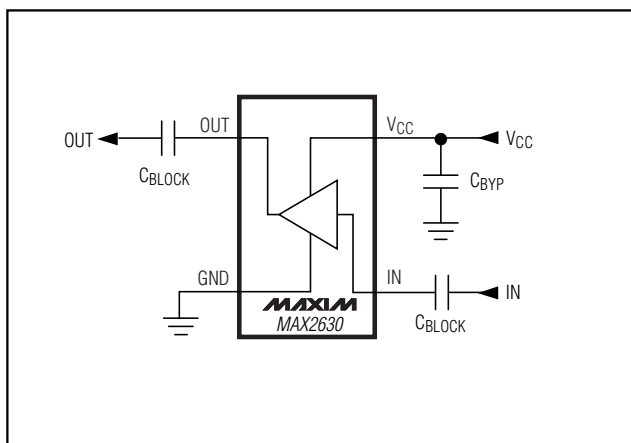

Figure 1. MAX2630 Typical Operating Circuit

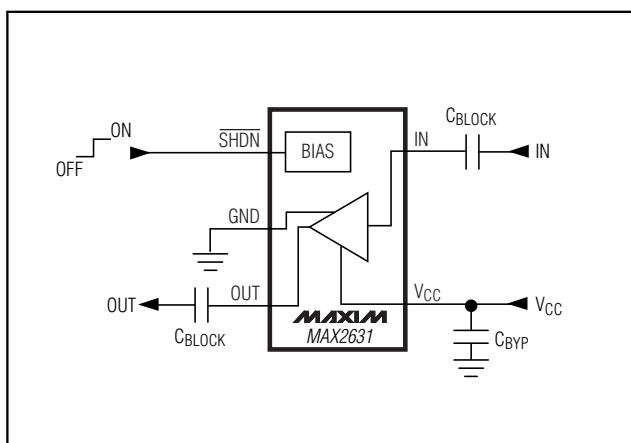

Figure 2. MAX2631 Typical Operating Circuit

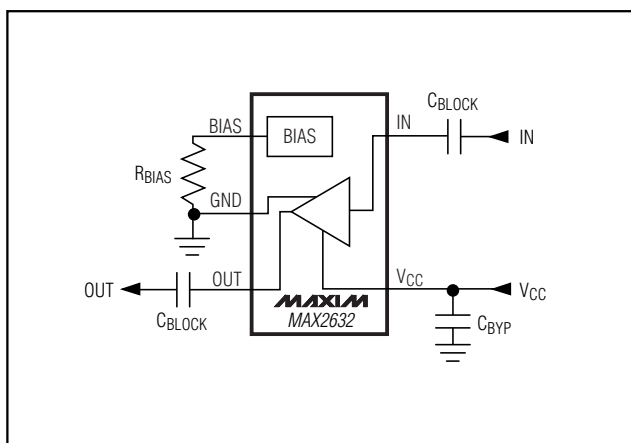

Figure 3. MAX2632 Typical Operating Circuit

VHF-to-Microwave, +3V, General-Purpose Amplifiers

PC Board Layout Example

Example PC board layouts are given in Figures 4 to 7. They use FR-4 with a 31mil layer thickness between the RF lines and the ground plane. The boards satisfy all of the above recommendations.

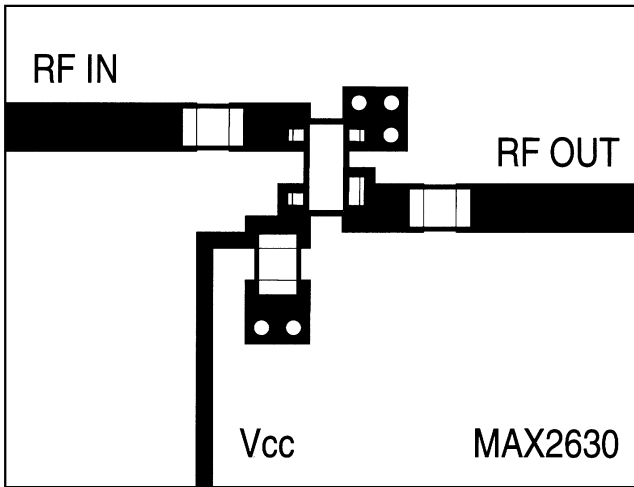

Figure 4. MAX2630 Example PC Board Layout

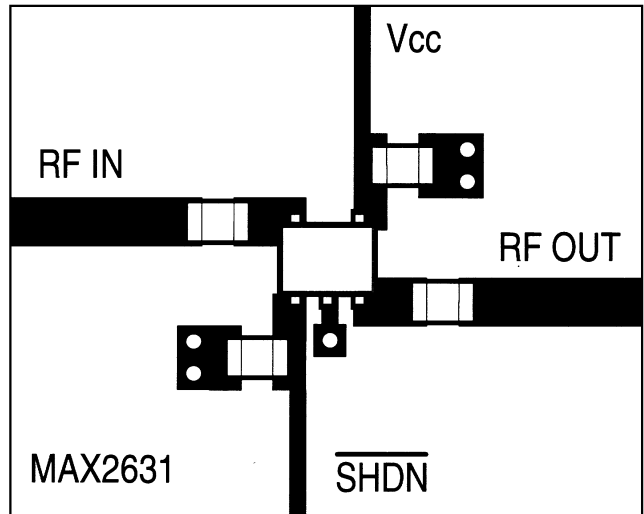

Figure 5. MAX2631 Example PC Board Layout

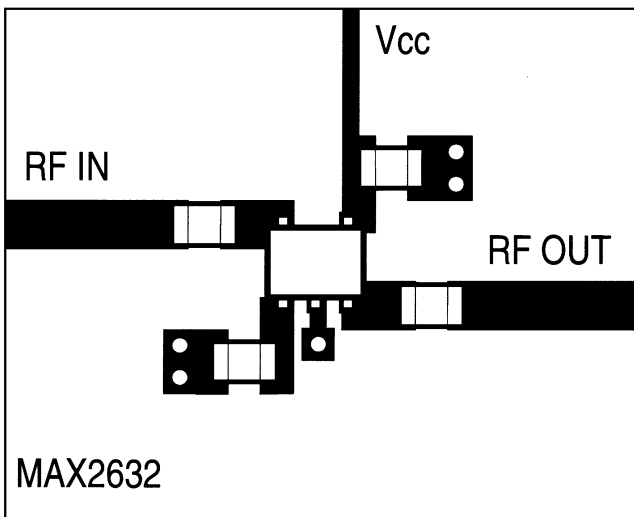

Figure 6. MAX2632 Example PC Board Layout

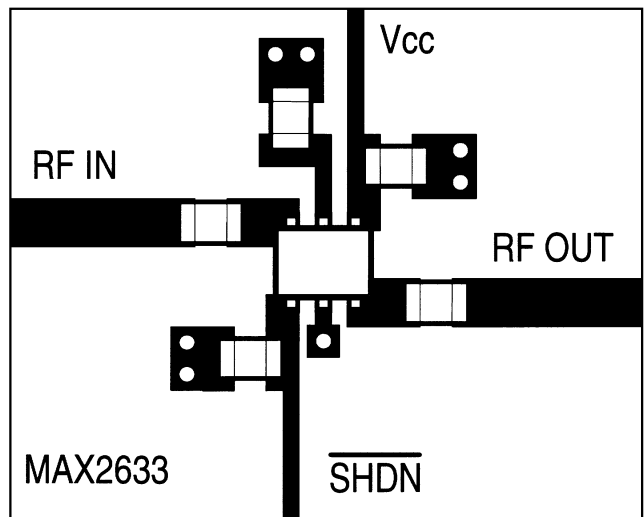

Figure 7. MAX2633 Example PC Board Layout

VHF-to-Microwave, +3V, General-Purpose Amplifiers

Chip Information

TRANSISTOR COUNT: 199

Tape-and-Reel Information

MAX2630-MAX2633

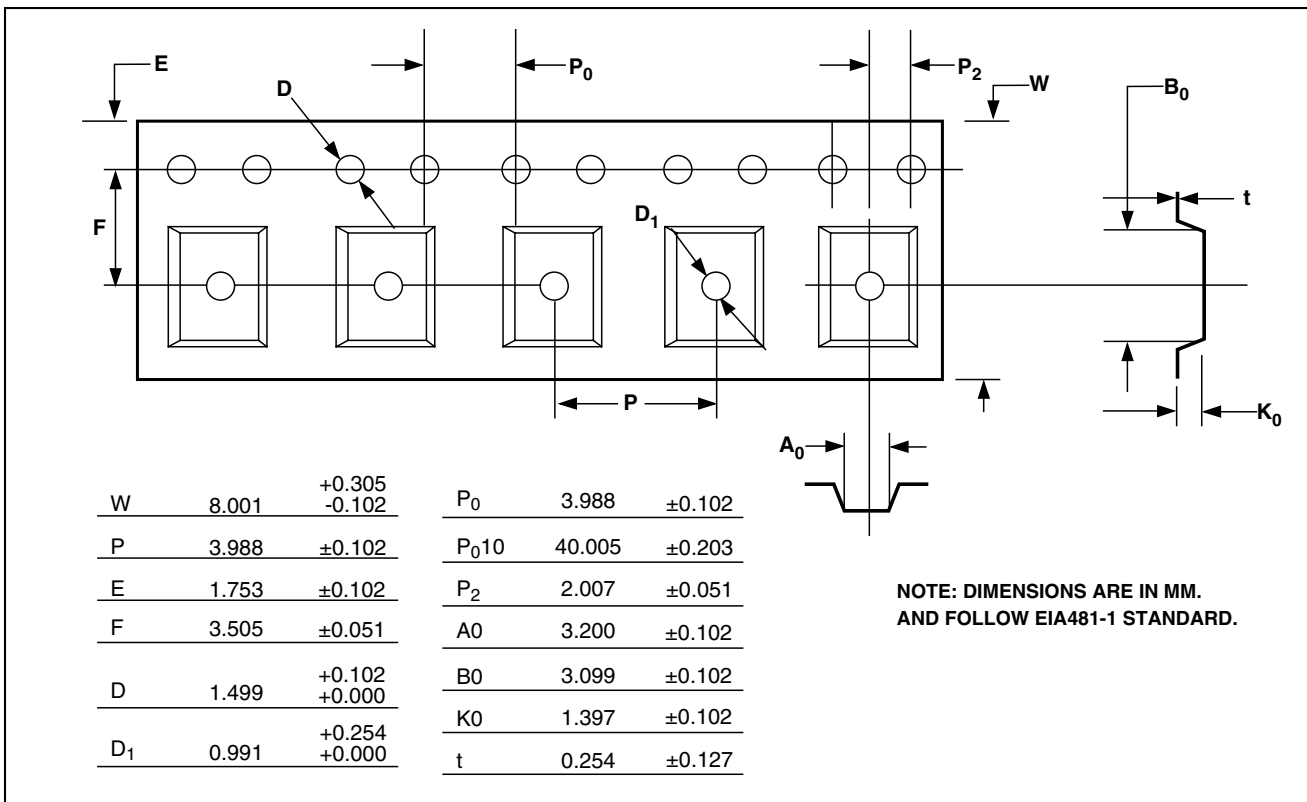

VHF-to-Microwave, +3V, General-Purpose Amplifiers

Package Information

(The package drawing(s) in this data sheet may not reflect the most current specifications. For the latest package outline information, go to www.maxim-ic.com/packages.)

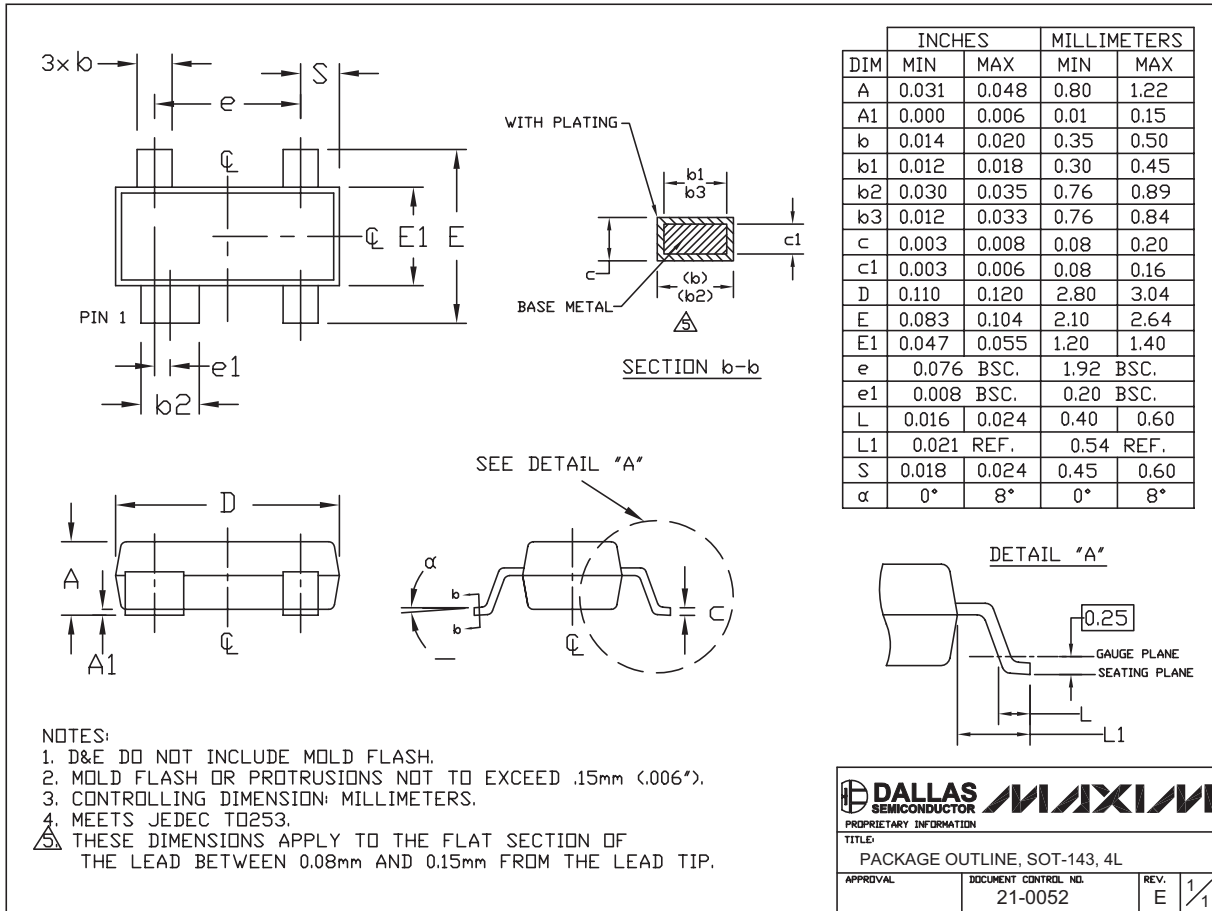

SOT-143 4LEPS

VHF-to-Microwave, +3V, General-Purpose Amplifiers

Package Information (continued)

(The package drawing(s) in this data sheet may not reflect the most current specifications. For the latest package outline information, go to www.maxim-ic.com/packages.)

MAX2630-MAX2633

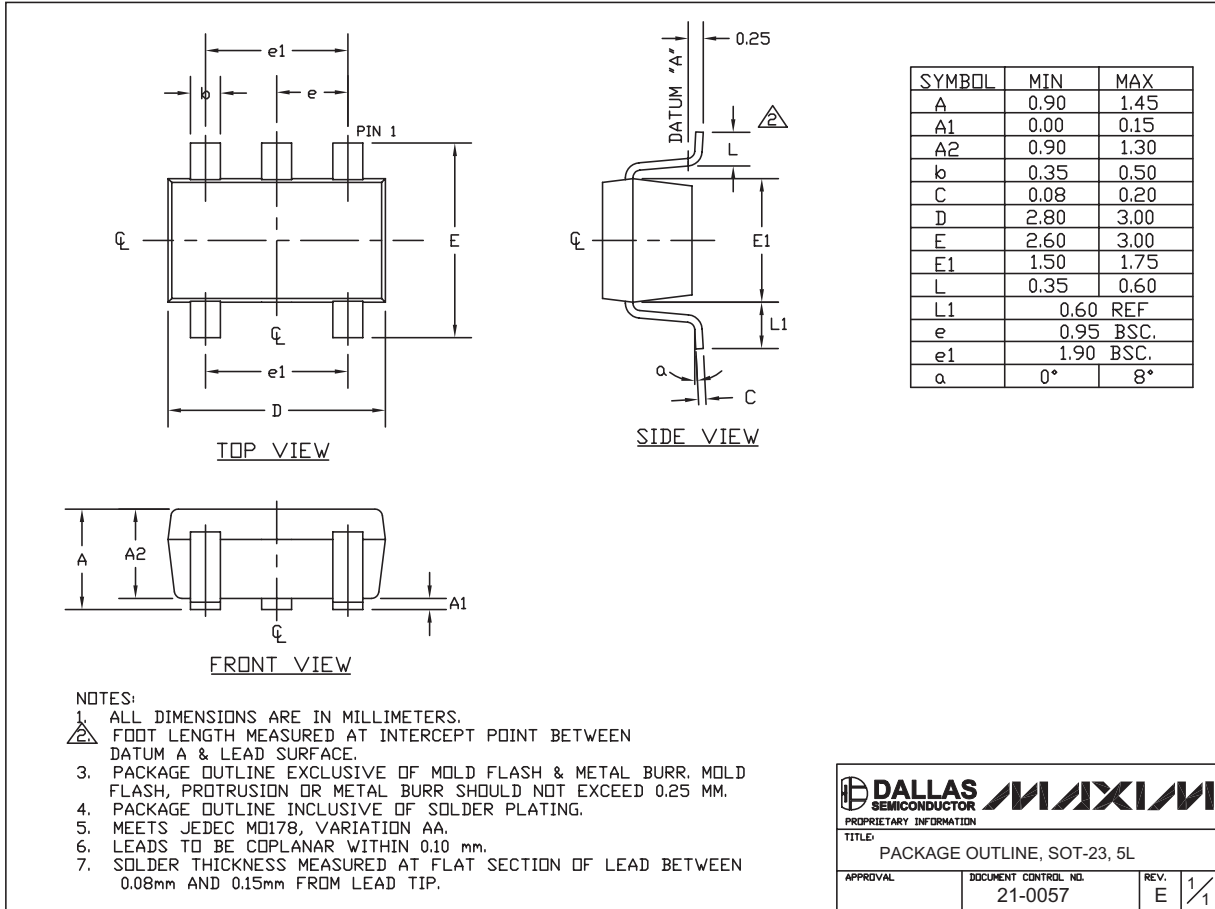

SOT-23 5L EPS

VHF-to-Microwave, +3V, General-Purpose Amplifiers

Package Information (continued)

(The package drawing(s) in this data sheet may not reflect the most current specifications. For the latest package outline information, go to www.maxim-ic.com/packages.)

SYMBOL	MIN	MAX
A	0.90	1.45
A1	0.00	0.15
A2	0.90	1.30
b	0.35	0.50
C	0.08	0.20
D	2.80	3.00
E	2.60	3.00
E1	1.50	1.75
L	0.35	0.60
L1	0.60	REF.
e1	1.90	BSC.
e	0.95	BSC.
a	0°	10°

NOTES:

- ALL DIMENSIONS ARE IN MILLIMETERS.
- FOOT LENGTH MEASURED AT INTERCEPT POINT BETWEEN DATUM A & LEAD SURFACE.
- PACKAGE OUTLINE EXCLUSIVE OF MOLD FLASH & METAL BURR. MOLD FLASH, PROTRUSION OR METAL BURR SHOULD NOT EXCEED 0.25 MM.
- PACKAGE OUTLINE INCLUSIVE OF SOLDER PLATING.
- PIN 1 IS LOWER LEFT PIN WHEN READING TOP MARK FROM LEFT TO RIGHT. (SEE EXAMPLE TOP MARK)
- PIN 1 I.D. DOT IS 0.3 MM ϕ MIN. LOCATED ABOVE PIN 1.
- MEETS JEDEC MO178, VARIATION AB.
- SOLDER THICKNESS MEASURED AT FLAT SECTION OF LEAD BETWEEN 0.08mm AND 0.15mm FROM LEADTIP.
- LEAD TO BE COPLANAR WITHIN 0.1 MM.

6LSOTEPS

Maxim cannot assume responsibility for use of any circuitry other than circuitry entirely embodied in a Maxim product. No circuit patent licenses are implied. Maxim reserves the right to change the circuitry and specifications without notice at any time.

12 Maxim Integrated Products, 120 San Gabriel Drive, Sunnyvale, CA 94086 408-737-7600