

EVALUATION KIT
AVAILABLE

MAXIM

Power Source Selector for Dual-Battery Systems

General Description

The MAX1773/MAX1773A highly integrated ICs serve as the control logic for a system with multiple power sources. They directly drive external P-channel MOSFETs to select from an AC adapter and dual battery sources for charge and discharge. The selection is made based on the presence of the power sources and the state of the batteries. The MAX1773/MAX1773A detect low battery conditions using integrated analog comparators and check for the presence of a battery by using battery thermistor outputs.

The MAX1773/MAX1773A are designed for use with a buck topology charger. They provide a simple and easily controlled solution to a difficult analog power control problem. The MAX1773/MAX1773A provide most of the power source monitoring and selection, freeing the system power management microprocessor (μ P) for other tasks. This not only simplifies development of the power management firmware for the μ P but also allows the μ P to enter standby, thereby reducing system power consumption.

The MAX1773A is recommended for new designs.

Applications

Notebook and Subnotebook Computers
PDAs and Handy-Terminals
Internet Tablets
Dual-Battery Portable Equipment

Features

- ◆ Patented† 7-MOSFET Topology Offers Low-Cost Solution
- ◆ Automatically Detects and Responds to:
 - Low Battery Voltage Condition
 - Battery Insertion and Removal
 - AC Adapter Presence
- ◆ Direct Drive of P-Channel MOSFETs
- ◆ Simplifies Power Management μ P Firmware
- ◆ Extends Battery Life by Allowing Power Management μ P to Enter Standby
- ◆ 4.75V to 28V AC Adapter Input Voltage Range
- ◆ Integrated LDO with 1mA Drive Capability
- ◆ Small Footprint 20-Pin TSSOP Package

Ordering Information

PART	TEMP. RANGE	PIN-PACKAGE
MAX1773EUP	-40°C to +85°C	20 TSSOP
MAX1773AEUP	-40°C to +85°C	20 TSSOP

Pin Configuration appears at end of data sheet.

† Covered by U.S. Patent number 5,764,032.

Typical Operating Circuit

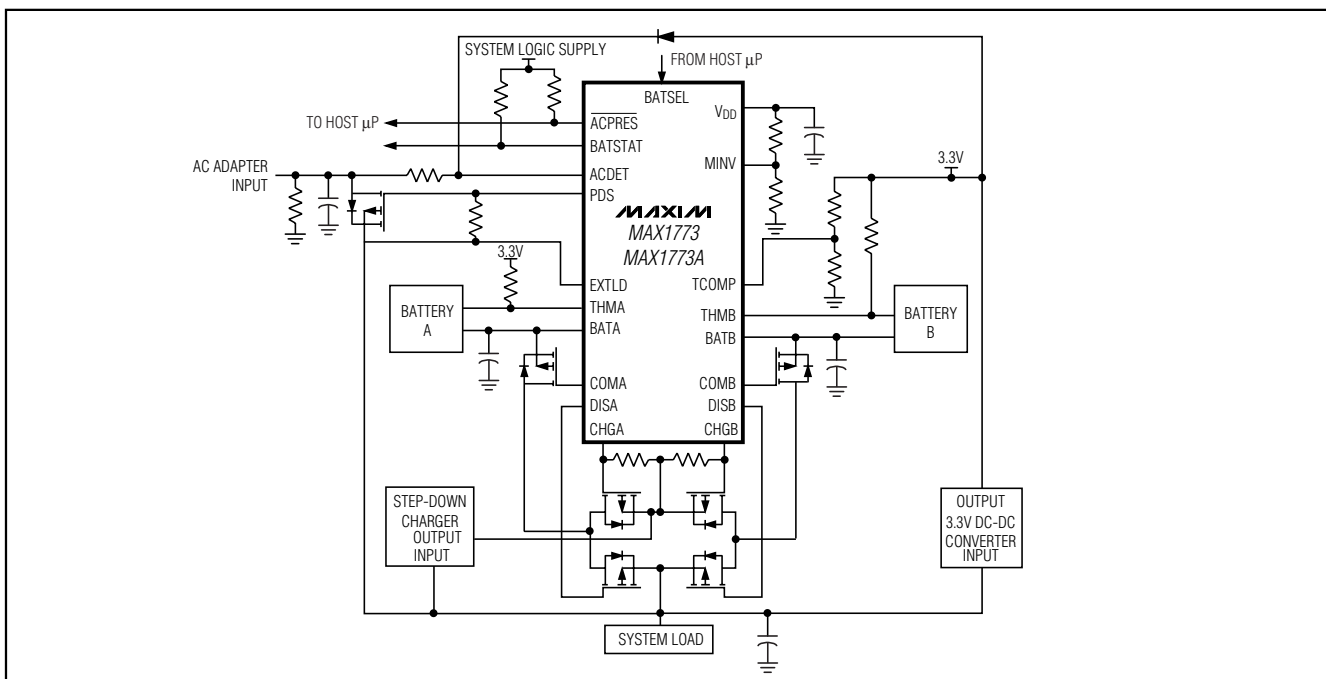

Power Source Selector for Dual-Battery Systems

ABSOLUTE MAXIMUM RATINGS

V _{BATA} , V _{BATB} to GND	-0.3V to +20V	Continuous Current out of THMA, THMB.....	20mA
V _{COMA} to GND.....	-0.3V to (V _{BATA} + 0.3V)	I _{ACPRES} , I _{BATSTAT} Sink Current.....	30mA
V _{COMB} to GND.....	-0.3V to (V _{BATB} + 0.3V)	Continuous Power Dissipation (T _A = +70°C)	
V _{CHGA} , V _{CHGB} , V _{EXTLD} , V _{ACDET} to GND	-0.3V to +30V	20-Pin TSSOP (derate 7.0mW/°C above +70°C)	560mW
V _{PDS} , V _{DISA} , V _{DISB} to GND.....	-0.3V to (V _{EXTLD} + 0.3V)	Operating Temperature	-40°C to +85°C
V _{DD} , V _{BATSEL} , V _{ACPRES} , V _{BATSTAT} , V _{TCOMP} , V _{MINV} to GND.....	-0.3V to +6V	Storage Temperature	-65°C to +150°C
V _{THMA} , V _{THMB} (Note 1).....	-0.3V to +6V	Lead Temperature (soldering, 10s)	+300°C

Note 1: Signals on THMA and THMB below -0.3V are clamped by internal diodes limit forward diode current to maximum continuous current. When voltage on these pins is below -0.3V.

Stresses beyond those listed under "Absolute Maximum Ratings" may cause permanent damage to the device. These are stress ratings only, and functional operation of the device at these or any other conditions beyond those indicated in the operational sections of the specifications is not implied. Exposure to absolute maximum rating conditions for extended periods may affect device reliability.

ELECTRICAL CHARACTERISTICS

(V_{BATA} = V_{BATB} = 16.8V, C_{VDD} = 3.3μF, V_{MINV} = 0.93V, V_{EXTLD} = V_{ACDET} = 28V, V_{TCOMP} = 3V, V_{THMA} = V_{THMB} = 1.65V, V_{BATSEL} = 0, C_{COMA} = C_{COMB} = C_{DISA} = C_{DISB} = C_{CHGA} = C_{CHGB} = C_{PDS} = 5nF, T_A = 0°C to +85°C, unless otherwise noted.)

PARAMETER	CONDITIONS	MIN	TYP	MAX	UNITS
EXTLD Supply Voltage Range	V _{EXTLD} > V _{BATA} and V _{BATB}	4.75		28.00	V
BATA, BATB Supply Voltage Range		4.75		19.00	V
BATA, BATB Quiescent Current (Current from the higher voltage supply)	V _{BATA} = 4.75V to 19V, V _{BATB} = 4.75V to 19V, I _{VDD} = 0	V _{ACDET} = 28V	5	8	μA
		V _{ACDET} = 2.2V to V _{BATA} and V _{BATB}	40	70	
BATA, BATB Quiescent Current (Current from the lower voltage supply)	V _{BATA} = 4.75V to 19V, V _{BATB} = 4.75V to 19V, I _{VDD} = 0	V _{ACDET} = 28V	5	8	μA
		V _{ACDET} = 2.2V to V _{BATA} and V _{BATB}	8	13	
EXTLD Quiescent Current	V _{ACDET} = 28V, V _{EXTLD} = 28V		35	55	μA
	V _{ACDET} = 2.2V to V _{BATA} and V _{BATB} , V _{EXTLD} = 16V		5	8	
LINEAR REGULATOR					
V _{DD} Output Voltage	I _{VDD} = 0 to 100μA	3.234	3.3	3.367	V
	I _{VDD} = 100μA to 1mA	3.168	3.3	3.432	
V _{DD} Power-Supply Rejection Ratio	V _{BATA} or V _{BATB} = 5V to 19V, V _{EXTLD} = 5V			1.0	mV/V
	V _{BATA} = V _{BATB} = 5V, V _{EXTLD} = 5V to 28V			1.0	
	V _{BATA} , V _{BATB} , or V _{EXTLD} = 5V to 19V, sawtooth at 10V/μs, other supplies = 12V		1		
V _{DD} Undervoltage Lockout	Hysteresis is typically 50mV	2.0	2.5	3.0	V
COMPARATORS					
TCOMP Undervoltage Lockout	(Note 2)	0		1.1	V
THM_ Input Voltage Range		0		5.5	V
THM_ Input Leakage Current	V _{THM_} = 5.5V		0.1	100	nA
TCOMP Input Voltage Range	V _{THMA} = V _{THMB} = 0 to 5.5V	0		5.5	V
	V _{THMA} = V _{THMB} = 0 to 5.5V, V _{BATA} = V _{BATB} = V _{EXTLD} = 4.75V	0		4.3	

Power Source Selector for Dual-Battery Systems

MAX1773/MAX1773A

ELECTRICAL CHARACTERISTICS (continued)

($V_{BATA} = V_{BATB} = 16.8V$, $C_{VDD} = 3.3\mu F$, $V_{MINV} = 0.93V$, $V_{EXTLD} = V_{ACDET} = 28V$, $V_{TCOMP} = 3V$, $V_{THMA} = V_{THMB} = 1.65V$, $V_{BATSEL} = 0$, $C_{COMA} = C_{COMB} = C_{DISA} = C_{DISB} = C_{CHGA} = C_{CHGB} = C_{PDS} = 5nF$, $T_A = 0^\circ C$ to $+85^\circ C$, unless otherwise noted.)

PARAMETER	CONDITIONS	MIN	TYP	MAX	UNITS	
TCOMP Input Leakage Current	$V_{TCOMP} = 5.5V$		0.1	100	nA	
THM_ to TCOMP Trip Threshold	THM_ falling with respect to TCOMP	-30		+30	mV	
THM_ to TCOMP Hysteresis		15	50		mV	
ACDET Operating Voltage Range	(Note 3)	2.2		28.0	V	
ACDET Logic Threshold High		2.2			V	
ACDET Input Bias Current	$V_{ACDET} = 3V$, $V_{ACDET} < V_{BATA}$ and V_{BATB}		4	8	μA	
	$V_{ACDET} = 3V$, $V_{ACDET} < V_{BATB}$, $V_{BATA} = 0$		5	9		
	$V_{ACDET} = 28V$, $V_{ACDET} > V_{BATA}$ and V_{BATB}		6	11		
ACDET to BATA Trip Threshold	V_{ACDET} falling with respect to V_{BATA}	0	50	100	mV	
ACDET to BATA Hysteresis		100	150	200	mV	
ACDET to BATB Trip Threshold	V_{ACDET} falling with respect to V_{BATB}	0	50	100	mV	
ACDET to BATB Hysteresis		100	150	200	mV	
MINV Operating Voltage Range	$V_{BATA} = V_{BATB} = 5 \times V_{MINV}$	0.93		2.60	V	
MINV Input Bias Current	$V_{MINV} = 0.93V$ to $2.6V$	-100		+100	nA	
BAT_ Minimum Voltage Trip Threshold	$V_{BAT_}$ falling	$V_{MINV} = 0.93V$	4.55	4.65	4.75	V
		$V_{MINV} = 2.6V$	12.7	13	13.3	
BATSEL Input Low Voltage	Typical hysteresis is 100mV			0.8	V	
BATSEL Input High Voltage		2.0			V	
BATSEL Input Leakage Current	$V_{BATSEL} = 5.5V$			1	μA	
BATSEL Action Delay		20		100	μs	
GATE DRIVERS						
COM_ Initial Source Current	$V_{BAT_} = 16.8V$, $V_{COM_} = 14.8V$	5			mA	
COM_ Final Source Current	$V_{BAT_} = 16.8V$, $V_{COM_} = 16.4V$	10			μA	
	$V_{BAT_} = 16.8V$, $V_{COM_} = 14.8V$	50	100	150		
COM_ Sink Current (PMOS Turn-On)	$V_{COM_} = 11.8V$, $V_{BAT_} = 16.8V$ (Note 4)	4			mA	
COM_ Turn-On Clamp Voltage ($V_{COM_}$ to $V_{BAT_}$)	$V_{BAT_} = 8V$ to $19V$	-11.5	-9.5	-7.5	V	
	$V_{BAT_} = 4.75V$ to $8V$	-8.00		-4.25		
PDS Source Current (PMOS Turn-Off)	$V_{PDS} = 10V$, $V_{EXTLD} = 12V$	5			mA	
PDS Sink Current (PMOS Turn-On)	$V_{PDS} = 2V$ to $28V$	0.8	1.0	1.2	mA	
PDS Leakage Current (PMOS Off)	$V_{PDS} = 28V$		0.1	2	μA	
CHG_ Sink Current (PMOS Turn-On)	$V_{CHG_} = 2V$ to $22V$	0.7	1.0	1.3	mA	
CHG_ Leakage Current (PMOS Off)	$V_{CHG_} = 28V$		0.1	2	μA	
DIS_ Initial Source Current	$V_{EXTLD} = 15V$, $V_{DIS_} = 13V$	5			mA	
DIS_ Final Source Current	$V_{EXTLD} = 15V$, $V_{DIS_} = 14.6V$	10			μA	
	$V_{EXTLD} = 15V$, $V_{DIS_} = 13V$	50	100	150		
DIS_ Sink Current (PMOS Turn-On)	$V_{EXTLD} = 16.8V$, $V_{DIS_} = 11.8V$ (Note 5)	4			mA	

Power Source Selector for Dual-Battery Systems

ELECTRICAL CHARACTERISTICS (continued)

(VBATA = VBATB = 16.8V, CVDD = 3.3μF, VMINV = 0.93V, VEXTLD = VACDET = 28V, VTCOMP = 3V, VTHMA = VTHMB = 1.65V, VBATSEL = 0, CCOMA = CCOMB = CDISA = CDISB = CCHGA = CCHGB = CPDS = 5nF, TA = 0°C to +85°C, unless otherwise noted.)

PARAMETER	CONDITIONS	MIN	TYP	MAX	UNITS
DIS_ Turn-On Clamp Voltage (V _{DIS} to V _{EXTLD})	V _{EXTLD} = 8V to 28V	-11.5	-9.5	-7.5	V
	V _{EXTLD} = 4.75V to 8V	-8.00		-4.25	
STATUS OUTPUTS					
ACPRES Sink Current	V _{ACPRES} = 0.4V	1			mA
	V _{ACPRES} = 5.5V			30	
BATSTAT Sink Current	V _{BATSTAT} = 0.4V	1			mA
	V _{BATSTAT} = 5.5V				
ACPRES Leakage Current	V _{ACPRES} = 5.5V		0.1	1	μA
BATSTAT Leakage Current	V _{BATSTAT} = 5.5V		0.1	1	μA
TRANSITION TIMES					
Battery Switchover Delay	V _{ACDET} = 2.2V, V _{MINV} = 0.93V (Note 6)			5	μs
Battery Action Delay	V _{ACDET} = 2.2V, V _{MINV} = 0.93V (Note 7)			260	μs
Thermistor Action Delay	V _{ACDET} = 2.2V, V _{MINV} = 0.93V (Note 8)			12	μs
AC to Battery Switchover Delay	V _{ACDET} = 2.2V, V _{MINV} = 0.93V (Note 9)			10	μs
Battery to AC Switchover Delay	V _{ACDET} = 2.2V, V _{MINV} = 0.93V (Note 10)			260	μs
CHG_ Turn-On Delay	(Note 11)	130	300	530	μs

ELECTRICAL CHARACTERISTICS

(VBATA = VBATB = 16.8V, CVDD = 3.3μF, VMINV = 0.93V, VEXTLD = VACDET = 28V, VTCOMP = 3V, VTHMA = VTHMB = 1.65V, VBATSEL = 0, CCOMA = CCOMB = CDISA = CDISB = CCHGA = CCHGB = CPDS = 5nF, TA = -40°C to +85°C, unless otherwise noted.)

PARAMETER	CONDITIONS	MIN	TYP	MAX	UNITS
EXTLD Supply Voltage Range	V _{EXTLD} > VBATA and VBATB	4.75		28.00	V
BATA, BATB Supply Voltage Range		4.75		19.00	V
BATA, BATB Quiescent Current (Current from the higher voltage supply)	VBATA = 4.75V to 19V, VBATB = 4.75V to 19V, I _{VDD} = 0	V _{ACDET} = 28V		8	μA
		V _{ACDET} = 2.2V to VBATA and VBATB		70	
BATA, BATB Quiescent Current (Current from the lower voltage supply)	VBATA = 4.75V to 19V, VBATB = 4.75V to 19V, I _{VDD} = 0	V _{ACDET} = 28V		8	μA
		V _{ACDET} = 2.2V to VBATA and VBATB		13	
EXTLD Quiescent Current	V _{ACDET} = 28V, V _{EXTLD} = 28V			55	μA
	V _{ACDET} = 2.2V to VBATA and VBATB, V _{EXTLD} = 16V			8	
LINEAR REGULATOR					
V _{DD} Output Voltage	I _{VDD} = 0 to 100μA	3.234		3.367	V
	I _{VDD} = 100μA to 1mA	3.168		3.432	
V _{DD} Power-Supply Rejection Ratio	VBATA or VBATB = 5V to 19V, V _{EXTLD} = 5V			1.0	mV/V
	VBATA = VBATB = 5V, V _{EXTLD} = 5V to 28V			1.0	
V _{DD} Undervoltage Lockout	Hysteresis is typically 50mV	2.0		3.0	V
COMPARATORS					
TCOMP Undervoltage Lockout	(Note 2)	0		1.1	V

Power Source Selector for Dual-Battery Systems

MAX1773/MAX1773A

ELECTRICAL CHARACTERISTICS (continued)

($V_{BATA} = V_{BATB} = 16.8V$, $C_{VDD} = 3.3\mu F$, $V_{MINV} = 0.93V$, $V_{EXTLD} = V_{ACDET} = 28V$, $V_{TCOMP} = 3V$, $V_{THMA} = V_{THMB} = 1.65V$, $V_{BATSEL} = 0$, $C_{COMA} = C_{COMB} = C_{DISA} = C_{DISB} = C_{CHGA} = C_{CHGB} = C_{PDS} = 5nF$, $T_A = -40^{\circ}C$ to $+85^{\circ}C$, unless otherwise noted.)

PARAMETER	CONDITIONS	MIN	TYP	MAX	UNITS
THM_ Input Voltage Range		0		5.5	V
THM_ Input Leakage Current	$V_{THM} = 5.5V$			100	NA
TCOMP Input Voltage Range	$V_{THMA} = V_{THMB} = 0$ to $5.5V$	0		5.5	V
	$V_{BATA} = V_{BATB} = V_{EXTLD} = 4.75V$	0		4.3	
ACDET Operating Voltage Range	(Note 3)	2.2		28.0	V
ACDET Logic Threshold High		2.2			V
ACDET Input Bias Current	$V_{ACDET} = 3V$, $V_{ACDET} < V_{BATA}$ and V_{BATB}			8	μA
	$V_{ACDET} = 3V$, $V_{ACDET} < V_{BATB}$, $V_{BATA} = 0$			9	
	$V_{ACDET} = 28V$, $V_{ACDET} > V_{BATA}$ and V_{BATB}			11	
ACDET to BATA Trip Threshold	V_{ACDET} falling with respect to V_{BATA}	-35		+125	mV
ACDET to BATA Hysteresis		100		200	mV
ACDET to BATB Trip Threshold	V_{ACDET} falling with respect to V_{BATB}	-35		+125	mV
ACDET to BATB Hysteresis		100		200	mV
MINV Operating Voltage Range	$V_{BATA} = V_{BATB} = 5 \times V_{MINV}$	0.93		2.60	V
MINV Input Bias Current	$V_{MINV} = 0.93V$ to $2.6V$	-100		+100	nA
BAT_ Minimum Voltage Trip Threshold	$V_{BAT_}$ falling	$V_{MINV} = 0.93V$	4.55	4.75	V
		$V_{MINV} = 2.6V$	12.7	13.3	
BATSEL Input Low Voltage	Typical hysteresis is 100mV			0.8	V
BATSEL Input High Voltage		2.0			V
BATSEL Input Leakage Current	$V_{BATSEL} = 5.5V$			1	μA
BATSEL Action Delay		20		100	μs
GATE DRIVERS					
COM_ Initial Source Current	$V_{BAT_} = 16.8V$, $V_{COM_} = 14.8V$	4			mA
COM_ Final Source Current	$V_{BAT_} = 16.8V$, $V_{COM_} = 16.4V$	10			μA
	$V_{BAT_} = 16.8V$, $V_{COM_} = 14.8V$	50		150	
COM_ Sink Current (PMOS Turn-On)	$V_{COM_} = 11.8V$, $V_{BAT_} = 16.8V$ (Note 4)	2			mA
COM_ Turn-On Clamp Voltage ($V_{COM_}$ to $V_{BAT_}$)	$V_{BAT_} = 8V$ to $19V$	-11.5		-7.25	V
	$V_{BAT_} = 4.75V$ to $8V$	-8.00		-4.25	
PDS Source Current (PMOS Turn-Off)	$V_{PDS} = 10V$, $V_{EXTLD} = 12V$	4			mA
PDS Sink Current (PMOS Turn-On)	$V_{PDS} = 2V$ to $28V$	0.7		1.3	mA
PDS Leakage Current (PMOS Off)	$V_{PDS} = 28V$			2	μA
CHG_ Sink Current (PMOS Turn-On)	$V_{CHG_} = 2V$ to $22V$	0.6		1.4	mA

Power Source Selector for Dual-Battery Systems

ELECTRICAL CHARACTERISTICS (continued)

($V_{BATA} = V_{BATB} = 16.8V$, $C_{VDD} = 3.3\mu F$, $V_{MINV} = 0.93V$, $V_{EXTLD} = V_{ACDET} = 28V$, $V_{TCOMP} = 3V$, $V_{THMA} = V_{THMB} = 1.65V$, $V_{BATSEL} = 0$, $C_{COMA} = C_{COMB} = C_{DISA} = C_{DISB} = C_{CHGA} = C_{CHGB} = C_{PDS} = 5nF$, $T_A = -40^{\circ}C$ to $+85^{\circ}C$, unless otherwise noted.)

DIS_ Sink Current (PMOS Turn-On)	$V_{EXTLD} = 16.8V$, $V_{DIS_} = 11.8V$ (Note 5)	2		mA
DIS_ Turn-On Clamp Voltage ($V_{DIS_}$ to V_{EXTLD})	$V_{EXTLD} = 8V$ to $28V$	-11.50	-7.25	V
	$V_{EXTLD} = 4.75V$ to $8V$	-8.00	-4.25	
STATUS OUTPUTS				
\overline{ACPRES} Sink Current	$V_{\overline{ACPRES}} = 0.4V$	1		mA
	$V_{\overline{ACPRES}} = 5.5V$		30	
BATSTAT Sink Current	$V_{BATSTAT} = 0.4V$	1		mA
	$V_{BATSTAT} = 5.5V$		30	
\overline{ACPRES} Leakage Current	$V_{\overline{ACPRES}} = 5.5V$		1	μA
BATSTAT Leakage Current	$V_{BATSTAT} = 5.5V$		1	μA
TRANSITION TIMES				
Battery Switchover Delay	$V_{ACDET} = 2.2V$, $V_{MINV} = 0.93V$ (Note 6)		5	μs
Battery Action Delay	$V_{ACDET} = 2.2V$, $V_{MINV} = 0.93V$ (Note 7)		260	μs
Thermistor Action Delay	$V_{ACDET} = 2.2V$, $V_{MINV} = 0.93V$ (Note 8)		12	μs
AC to Battery Switchover Delay	$V_{ACDET} = 2.2V$, $V_{MINV} = 0.93V$ (Note 9)		10	μs
Battery to AC Switchover Delay	$V_{ACDET} = 2.2V$, $V_{MINV} = 0.93V$ (Note 10)		260	μs
CHG_ Turn-On Delay	(Note 11)	130	530	μs

Note 2: TCOMP undervoltage lockout sets the MAX1773/MAX1773A's internal status bits for the batteries to be designated as "absent" ($V_{THM_} > V_{TCOMP}$).

Note 3: VACDET must remain above 2.2V, except in power-up.

Note 4: COMA cannot sink current until $V_{COMB} > V_{BATB} - 2V$. Likewise, COMB cannot sink current until $V_{COMA} > V_{BATA} - 2V$.

Note 5: DISA cannot sink current until $V_{DISB} > V_{EXTLD} - 2V$. Likewise, DISB cannot sink current until $V_{DISA} > V_{EXTLD} - 2V$.

Note 6: Battery Switchover Delay starts when either $V_{COM_}$ or $V_{DIS_}$ of the connected battery begins to rise and ends when both $V_{COM_}$ and $V_{DIS_}$ of the other battery have fallen 3V below their sources (Figures 1 and 2).

Note 7: Battery Action Delay starts when the connected battery's voltage falls below $5 \times V_{MINV}$ and ends when both $V_{COM_}$ and $V_{DIS_}$ of the other battery have fallen 3V below their sources (Figures 1 and 2).

Note 8: Thermistor Action Delay begins when $V_{THM_}$ of the connected battery rises above V_{TCOMP} and ends when both $V_{COM_}$ and $V_{DIS_}$ of the other battery have fallen 3V below their sources (Figures 3 and 4).

Note 9: AC to Battery Switchover Delay begins when VACDET falls below its threshold and ends when both $V_{COM_}$ and $V_{DIS_}$ of the battery being switched to have fallen 3V below their sources (Figure 5).

Note 10: Battery to AC Switchover Delay begins when VACDET rises above its threshold and ends when $V_{DIS_}$ of the battery being switched from has begun to rise (Figure 6).

Note 11: CHG_ Turn-on Delay begins when $V_{CHG_}$ of the battery being switched from begins to rise and ends when $V_{CHG_}$ of the battery being switched to begins to fall (Figures 7 and 8).

Power Source Selector for Dual-Battery Systems

Typical Operating Characteristics

($T_A = +25^\circ\text{C}$, unless otherwise noted.)

MAX1773/MAX1773A

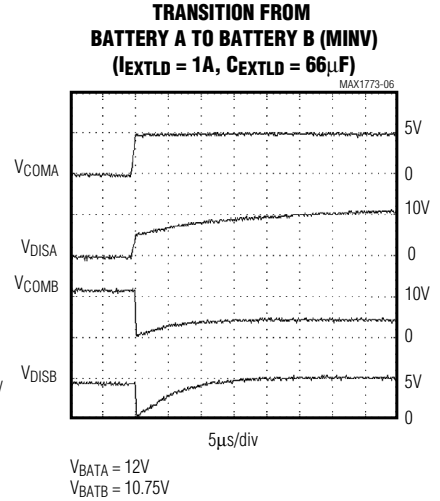
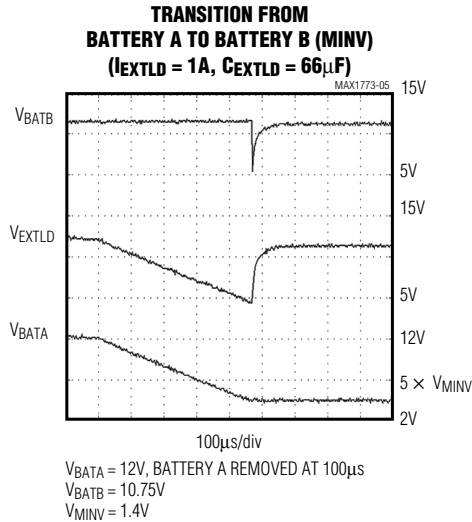
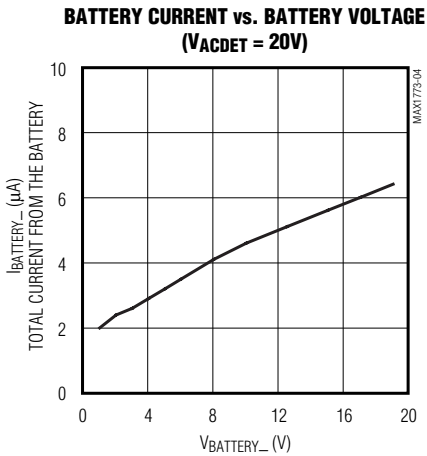
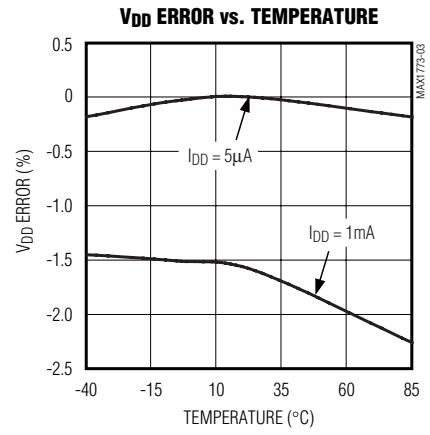
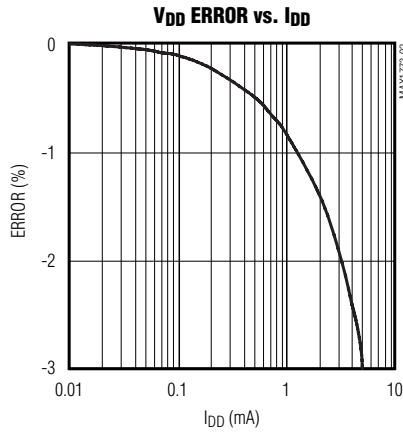
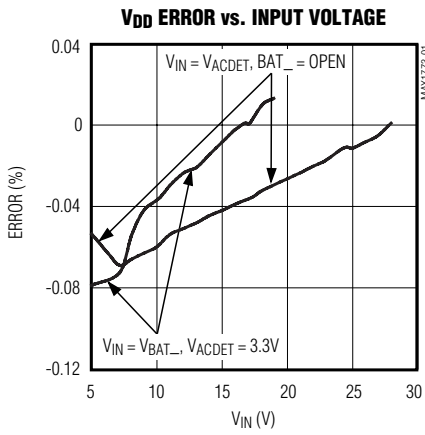

Power Source Selector for Dual-Battery Systems

Typical Operating Characteristics (continued)

($T_A = +25^\circ\text{C}$, unless otherwise noted.)

TRANSITION FROM BATTERY A TO BATTERY B (T_{COMP})
($I_{EXTLD} = 4\text{A}$, $C_{EXTLD} = 66\mu\text{F}$)

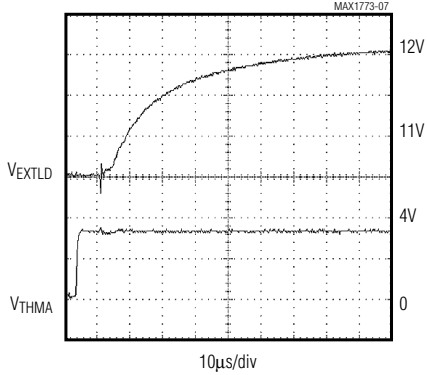

$V_{BATA} = 10.5\text{V AT } 4\text{A}$
 $V_{BATB} = 12\text{V AT } 4\text{A}$

TRANSITION FROM BATTERY A TO BATTERY B (T_{COMP})
($I_{EXTLD} = 4\text{A}$, $C_{EXTLD} = 66\mu\text{F}$)

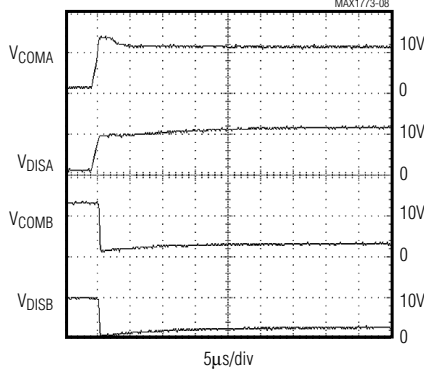

$V_{BATA} = 10.5\text{V AT } 4\text{A}$
 $V_{BATB} = 12\text{V AT } 4\text{A}$

TRANSITION FROM BATTERY A TO BATTERY B (BATSEL)
($I_{EXTLD} = 4\text{A}$, $C_{EXTLD} = 66\mu\text{F}$)

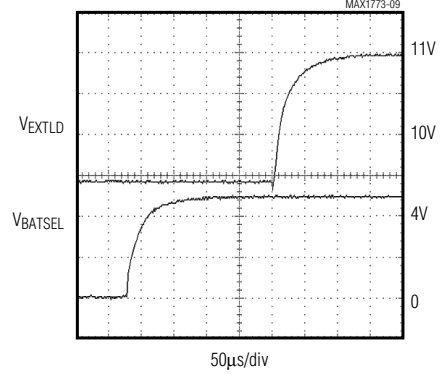

$V_{BATA} = 9.4\text{V AT } 4\text{A}$
 $V_{BATB} = 10.8\text{V AT } 4\text{A}$

TRANSITION FROM AC ADAPTER TO BATTERY A
($I_{EXTLD} = 4\text{A}$, $C_{EXTLD} = 66\mu\text{F}$)

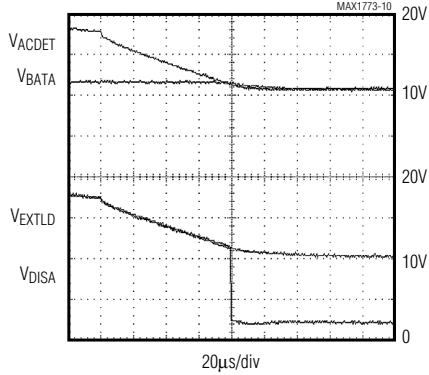

$V_{BATA} = 10.8\text{V AT } 4\text{A}$
 $V_{ACADAPTER} = 17.5\text{V AT } 4\text{A}$

TRANSITION FROM BATTERY A TO AC ADAPTER
($I_{EXTLD} = 4\text{A}$, $C_{EXTLD} = 66\mu\text{F}$)

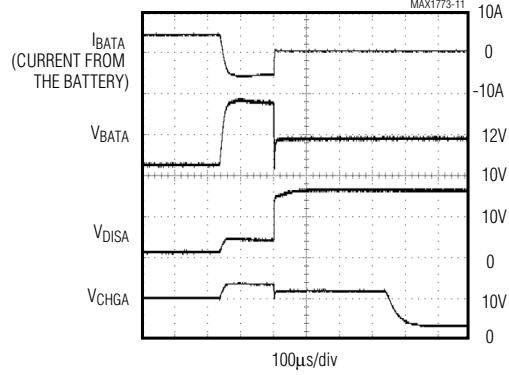

$V_{ACADAPTER} = 17.5\text{A AT } 4\text{A}$
 $V_{BATA} = 10.5\text{V AT } 4\text{A}$
 $V_{ACADAPTER}$ APPLIED AT $240\mu\text{s}$
CHARGER INPUT OPEN

Power Source Selector for Dual-Battery Systems

Pin Description

PIN	NAME	FUNCTION
1	BATA	Battery A Connection
2	THMA	Thermistor A Input
3	CHGA	Open-Drain Gate Driver for Charge Path MOSFET to Battery A
4	DISA	Gate Driver for Discharge Path MOSFET to Battery A. Switches from VEXTLD to (VEXTLD - 9.5V).
5	COMA	Gate Driver for Common Path MOSFET to Battery A. Switches from VBATA to (VBATA - 9.5V).
6	GND	Ground
7	MINV	Minimum Operating Voltage Set Point. The battery voltage switchover set point is $5 \times V_{MINV}$.
8	EXTLD	External Load Connection. Source connection for the PDS, DISA, and DISB MOSFETs.
9	PDS	Gate Driver for the AC Adapter MOSFET
10	ACDET	AC Adapter Detection Input
11	BATSTAT	Open-Drain Battery Status Output. Use a pullup resistor to the system logic supply.
12	ACPRES	Open-Drain AC Presence Output. Use a pullup resistor to the system logic supply.
13	BATSEL	Battery Select Digital Input. Selects which battery to charge or discharge.
14	TCOMP	Externally Set Thermistor Trip Point. Sets the thermistor voltage level for detecting the battery's presence.
15	VDD	Linear Regulator Output
16	COMB	Gate Driver for Common Path MOSFET to Battery B. Switches from VBATB to (VBATB - 9.5V).
17	DISB	Gate Driver for Discharge Path MOSFET to Battery B. Switches from VEXTLD to (VEXTLD - 9.5V).
18	CHGB	Open-Drain Gate Driver for Charge Path MOSFET to Battery B
19	THMB	Thermistor B Input
20	BATB	Battery B Connection

MAX1773/MAX1773A

Power Source Selector for Dual-Battery Systems

Transition Time Diagrams

(V_{COM_GS} = COM_ turn-on clamp voltage, V_{DIS_GS} = DIS_ turn-on clamp voltage, $V_{CHARGER}$ = system step-down charger output.)

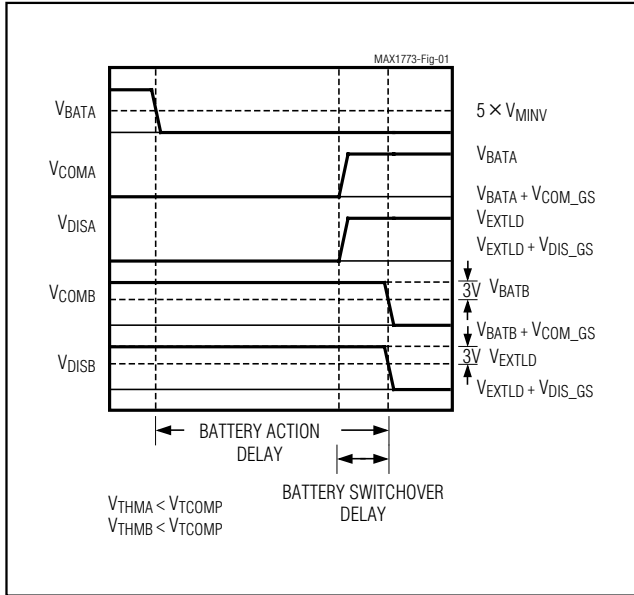

Figure 1. Battery Delay (Battery A to Battery B)

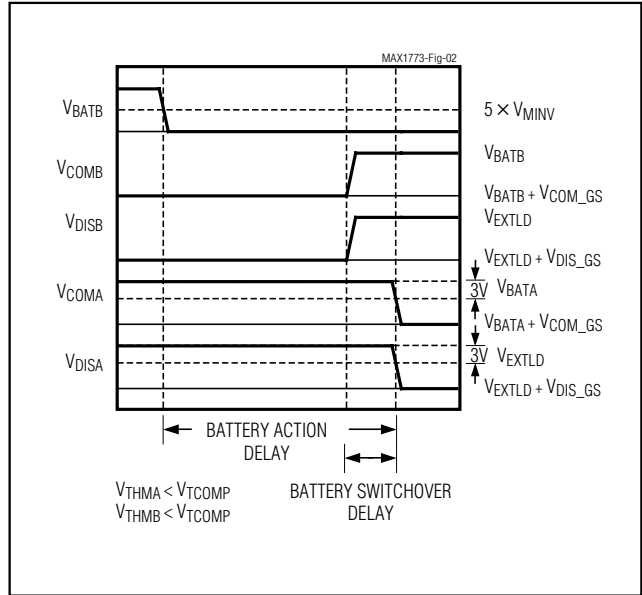

Figure 2. Battery Delay (Battery B to Battery A)

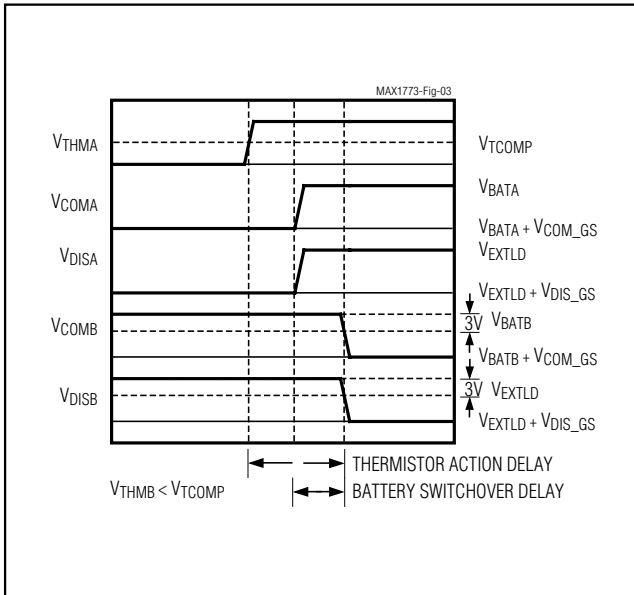

Figure 3. Thermistor Switchover Delay (Battery A to Battery B)

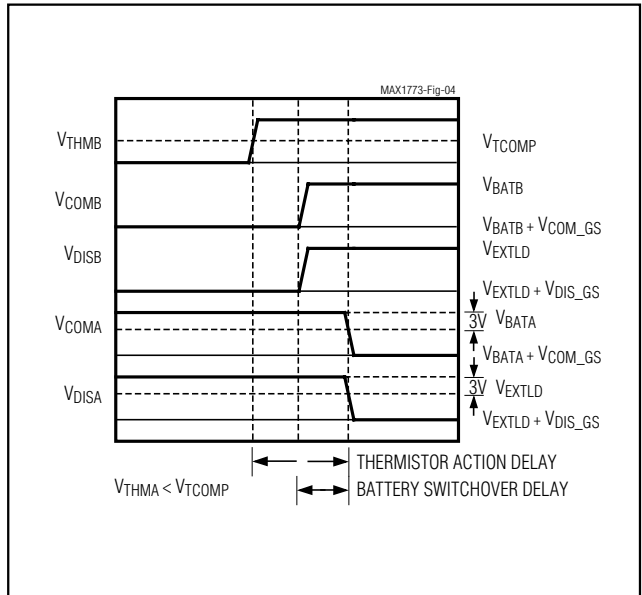

Figure 4. Thermistor Switchover Delay (Battery B to Battery A)

Power Source Selector for Dual-Battery Systems

Transition Time Diagrams (continued)

(V_{COM_GS} = COM_ turn-on clamp voltage, V_{DIS_GS} = DIS_ turn-on clamp voltage, $V_{CHARGER}$ = system step-down charger output.)

MAX1773/MAX1773A

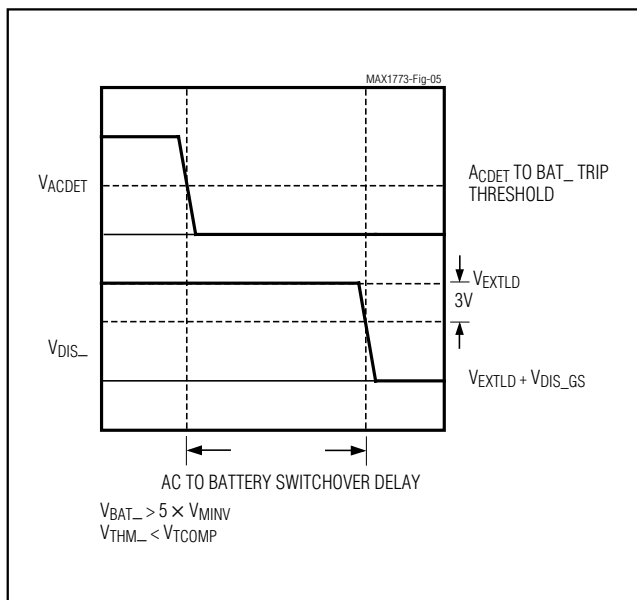

Figure 5. AC to Battery Switchover Delay

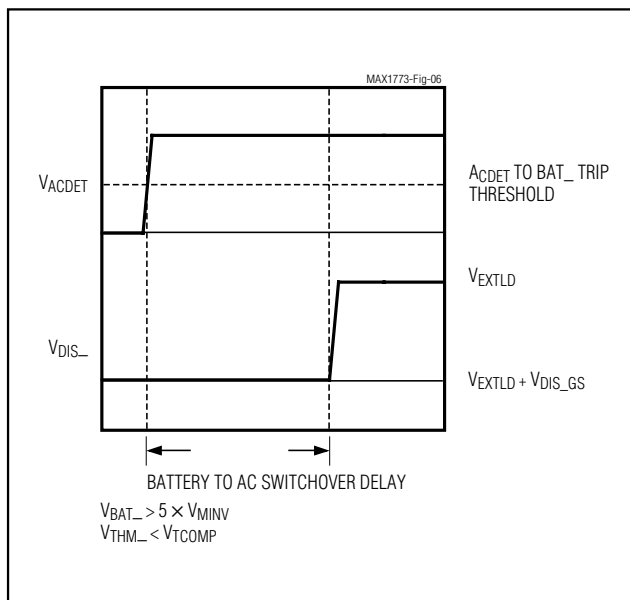

Figure 6. Battery to AC Switchover Delay

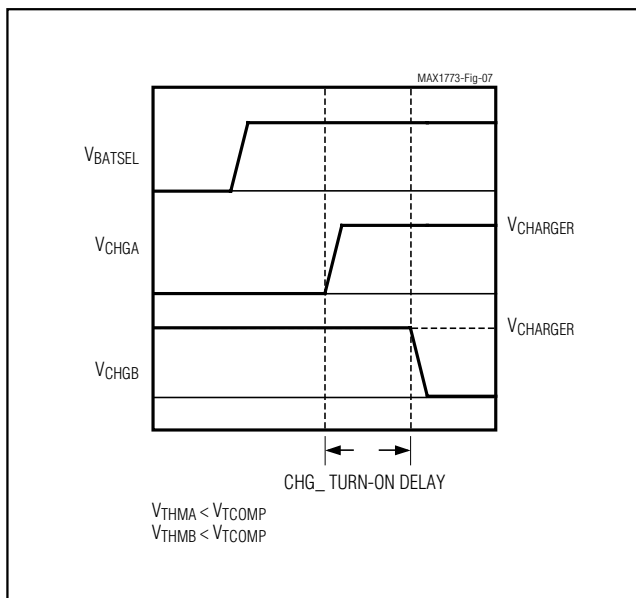

Figure 7. Charge Turn-On Delay (Battery A to Battery B)

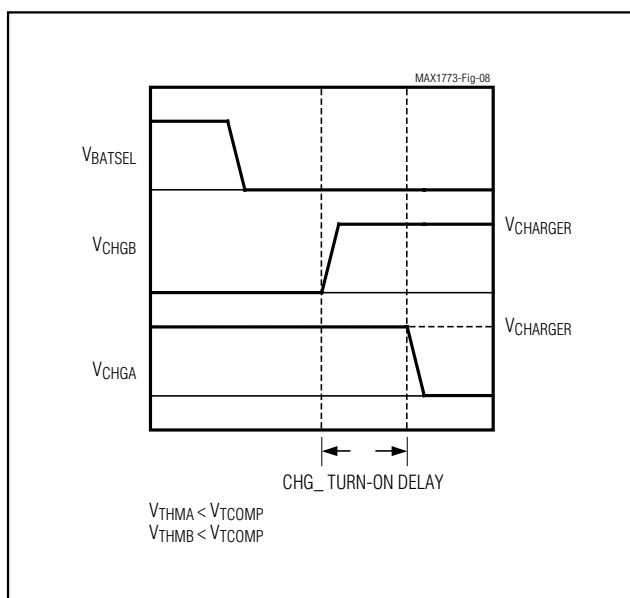

Figure 8. Charge Turn-On Delay (Battery B to Battery A)

Power Source Selector for Dual-Battery Systems

Table 1. AC Adapter States

BATSEL	BATTERY A	BATTERY B	BATSTAT	CONNECTION STATE
0	Present	X	0	AC adapter is connected to load. Battery A's charge path connected.
0	Absent	X	1	AC adapter is connected to load.
1	X	Present	1	AC adapter is connected to load. Battery B's charge path connected.
1	X	Absent	0	AC adapter is connected to load.

X = Don't care, Present: $V_{THM_} < V_{TCOMP}$, Absent: $V_{THM_} > V_{TCOMP}$, $\overline{ACPRES} = 0$

Table 2. Simplified Standard Battery States (without latches)

BATSEL	BATTERY A	VBATA	BATTERY B	VBATB	BATSTAT	CONNECTION STATE
0	Present	$>5 \times V_{MINV}$	X	X	0	Battery A is connected to the load.
X	Present	$>5 \times V_{MINV}$	Absent	X	0	Battery A is connected to the load.
X	Present	$>5 \times V_{MINV}$	X	$< 5 \times V_{MINV}$	0	Battery A is connected to the load.
X	X	$<5 \times V_{MINV}$	Present	$> 5 \times V_{MINV}$	1	Battery B is connected to the load.
X	Absent	X	Present	$> 5 \times V_{MINV}$	1	Battery B is connected to the load.
1	X	X	Present	$> 5 \times V_{MINV}$	1	Battery B is connected to the load.

X = Don't care, Present: $V_{THM_} < V_{TCOMP}$, Absent: $V_{THM_} > V_{TCOMP}$

Detailed Description

The MAX1773/MAX1773A provide the functions necessary to allow an external controller to manage the power connections needed for two battery packs, an AC adapter input, a battery charger, and the system load. The MAX1773/MAX1773A use seven PMOS FETs to provide all the switching necessary in systems using a step-down charger powered by the AC adapter (Figures 9 and 10). The MAX1773/MAX1773A automatically adapt to many transient conditions—such as AC plug-in, battery hot swapping, and battery switchover—to provide constant power to the system without requiring real-time support from an external controller. The MAX1773/MAX1773A draw their power from the highest voltage supply present (Figure 11).

Battery Detection

The MAX1773/MAX1773A monitor the battery's thermistor voltage to determine the presence of the battery. The devices compare the battery's thermistor voltage ($V_{THM_}$) to the thermistor trip point (V_{TCOMP}). If $V_{THM_} < V_{TCOMP}$, then the MAX1773/MAX1773A assume that the battery is present. However, if $V_{THM_} > V_{TCOMP}$, the MAX1773/MAX1773A assume that the battery is absent and do not charge or discharge the battery.

Modes of Operation

The MAX1773/MAX1773A provide three modes of operation. Start-up States mode provides functionality when the MAX1773/MAX1773A are initially powered by a bat-

tery when no AC adapter is present. AC adapter States mode provides functionality when an AC Adapter is present. Standard Battery States mode provides functionality when one or both batteries are present, the AC adapter is not present, and $EXTLD$ is above 2.2V. The Standard Battery States mode requires an external supply with an output voltage between 2.2V and 4.5V for $ACDET$, as shown in Figure 10. The external power supply must be powered from $EXTLD$.

AC Adapter States

The MAX1773/MAX1773A check for the presence of an AC adapter by sensing the voltage at $ACDET$. When V_{ACDET} exceeds the batteries' voltage and 4.75V, then the MAX1773/MAX1773A use the AC adapter to power the load. In addition, if the selected battery is present, the MAX1773/MAX1773A connect the selected battery's charge path. See Table 1 for a detailed listing of the MAX1773/MAX1773A states for operation with an AC adapter detected.

Standard Battery States

When the AC adapter power supply is not present, the MAX1773/MAX1773A use the batteries to supply the load. $BATSEL$ allows an external controller to select a battery. Table 2 shows the simplified standard battery states that normally control operation. However, the Battery Switchover Latch, the Low-Battery Latch, and the Discharged Battery Latch are able to suspend the state table and provide additional functionality.

Power Source Selector for Dual-Battery Systems

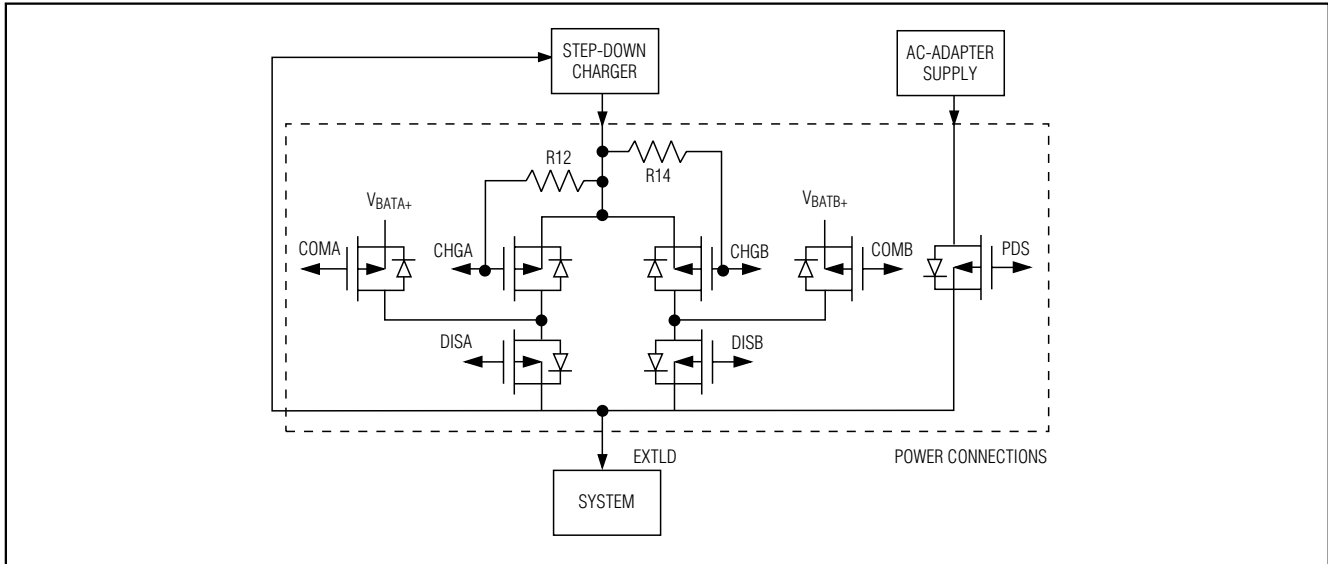

Figure 9. 7-MOSFET Topology

Table 3. Startup States

VBATA	VBATB	BATTERY A	BATTERY B	CONNECTION STATE
$>5 \times V_{MINV}$	X	Present	X	Battery A is connected to the load.
$<5 \times V_{MINV}$	$>5 \times V_{MINV}$	Present	Present	Battery B is connected to the load.
X	$>5 \times V_{MINV}$	Absent	Present	Battery B is connected to the load.
X	X	Absent	Absent	No connections.
$<5 \times V_{MINV}$	$<5 \times V_{MINV}$	X	X	No connections.
$<5 \times V_{MINV}$	X	X	Absent	No connections.
X	$<5 \times V_{MINV}$	Absent	X	No connections.

X = Don't care, Present: $V_{THM_} < V_{TCOMP}$, Absent: $V_{THM_} > V_{TCOMP}$

The Battery Switchover Latch stops the MAX1773/MAX1773A from oscillating when the device switches from the selected battery and then the selected battery's voltage recovers. According to the state table, the MAX1773/MAX1773A would switch back to the selected battery as soon as the battery's voltage recovered. The Battery Switchover Latch suspends the state table as soon as the MAX1773/MAX1773A switch over to the nonselected battery. This causes the MAX1773/MAX1773A to continue to power from the nonselected battery unless the latch is cleared. The Battery Switchover Latch is cleared when BATSEL is toggled (to select the other battery), when in the Startup States mode, in the AC Adapter States mode, and when the selected battery is removed ($V_{THM_} > V_{TCOMP}$).

To prevent the MAX1773/MAX1773A from switching to a discharged battery, the Low-Battery Latch suspends the state table when the unconnected battery's voltage is below $5 \times V_{MINV}$ and the discharging battery's voltage drops below $5 \times V_{MINV}$. Instead of switching to the unconnected battery, the MAX1773/MAX1773A continue to power from the discharging battery. This latch is cleared when the unconnected battery is removed ($V_{THM_} > V_{TCOMP}$), when in the Startup States mode, when in the AC Adapter States mode, and if the unconnected battery's voltage rises above $5 \times V_{MINV}$.

The Discharged Battery Latch sets whenever the MAX1773/MAX1773A are in the Standard Battery States mode, both batteries are present ($V_{THM_} < V_{TCOMP}$), one of the batteries is low ($V_{BAT_} < 5 \times V_{MINV}$), and the other battery's voltage is below V_{ACDET} . While the

Power Source Selector for Dual-Battery Systems

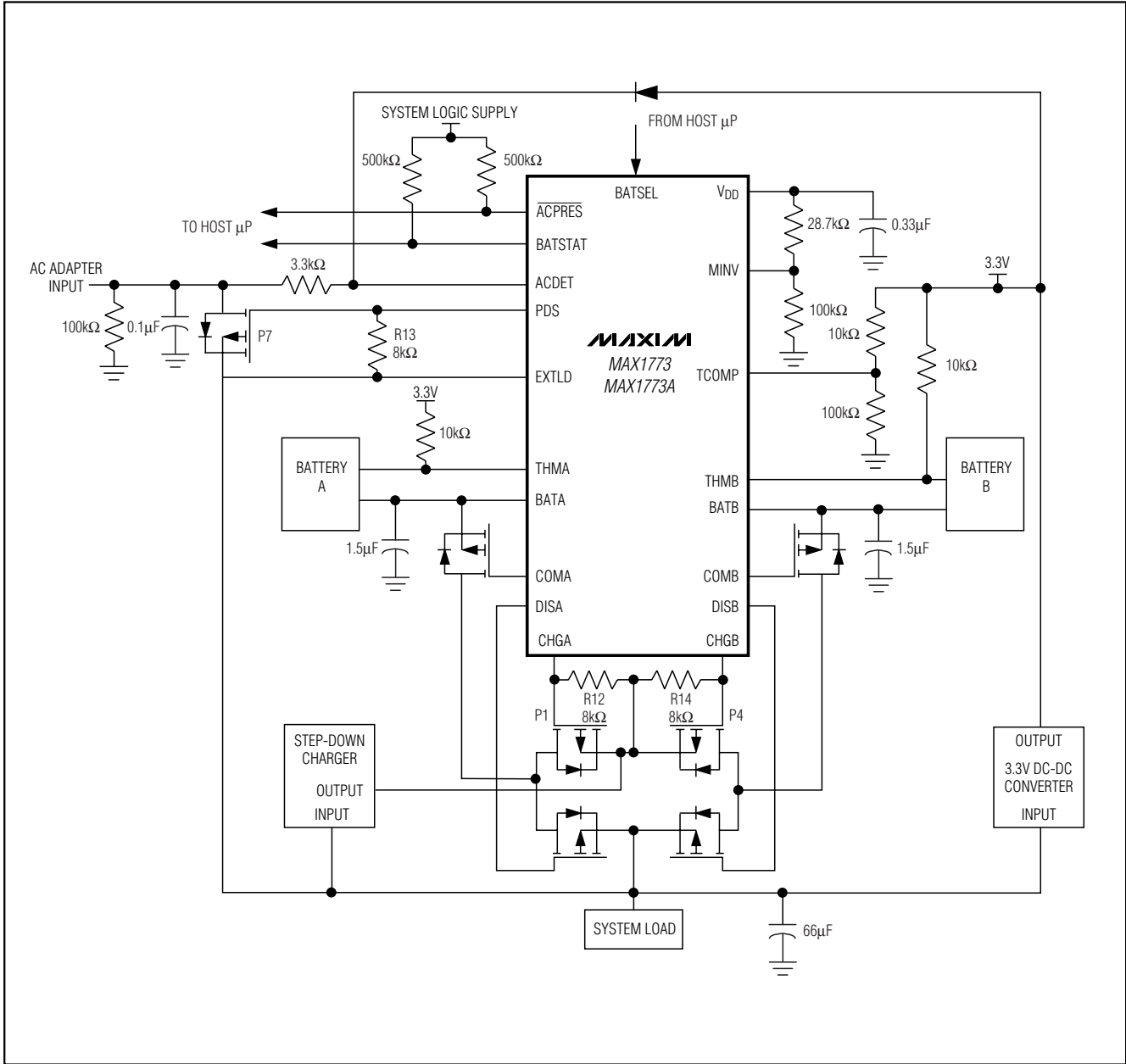

Figure 10. Standard Application Circuit

Discharged Battery Latch is set, the state table is suspended, the MAX1773/MAX1773A are not allowed to switch batteries, and the Low Battery Latch is cleared. The Discharged Battery Latch is cleared when both batteries are above V_{ACDET} , in the AC Adapter States mode, and in the Startup States mode.

Startup States

When V_{ACDET} rises at startup, the MAX1773/MAX1773A use Startup States. See Table 3 for a detailed listing of the MAX1773/MAX1773A states in this mode. Note that once V_{ACDET} rises above 2.2V, the MAX1773/MAX1773A are no longer in the Startup

Power Source Selector for Dual-Battery Systems

MAX1773/MAX1773A

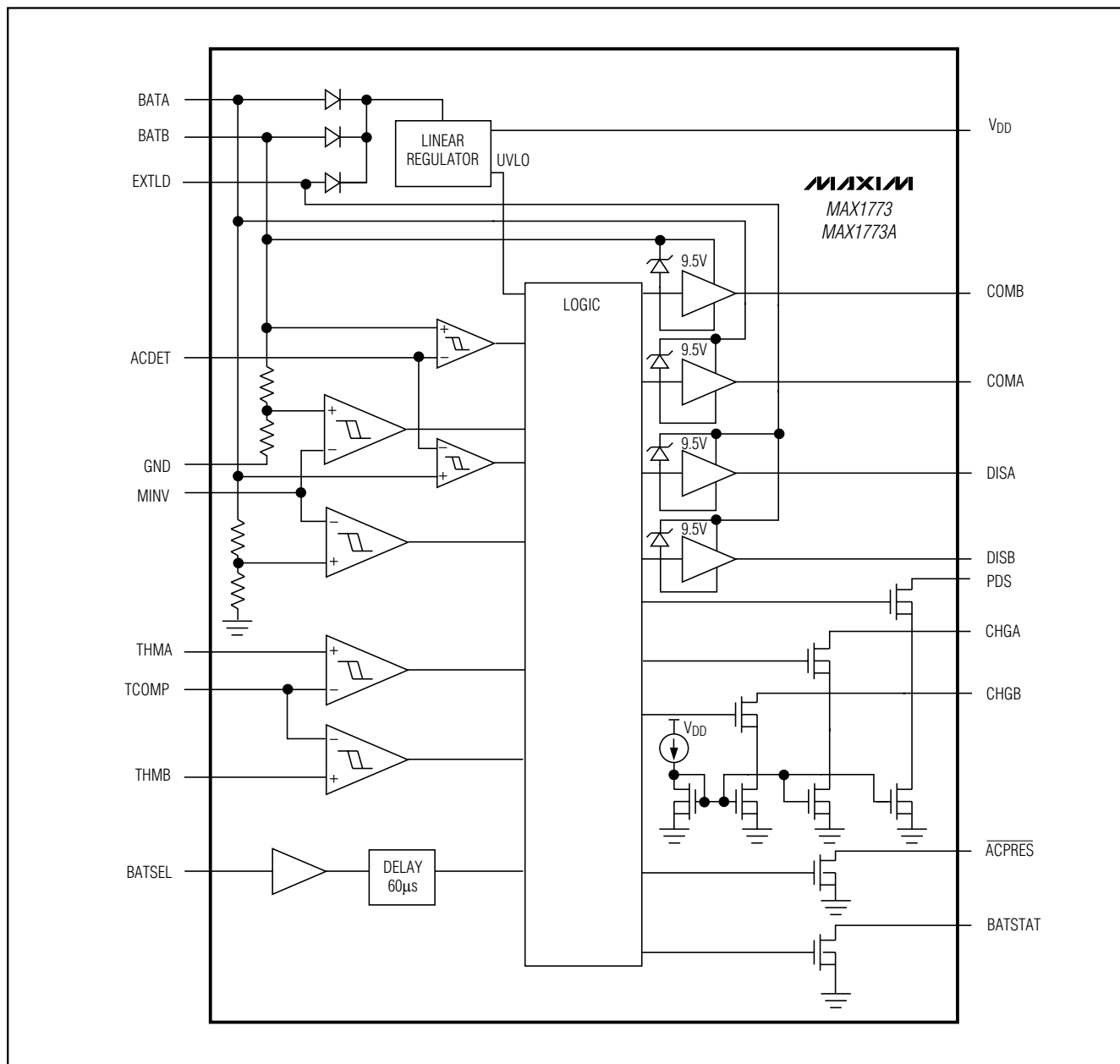

Figure 11. Functional Diagram

States mode and enters either the Standard Battery States mode or the AC Adapter States mode.

Status and Configuration

BATSTAT and $\overline{\text{ACPRES}}$ provide information to an external controller. Table 4 shows the different states of BATSTAT and $\overline{\text{ACPRES}}$.

In the AC Adapter States mode, the BATSEL Action Delay (see *Electrical Characteristics*) allows the external controller to tell if both batteries are absent. When both batteries are absent in the AC Adapter States mode and BATSEL changes states, BATSTAT is immediately updated. However, changes to the connection states are delayed (see Table 1 for connection states).

Power Source Selector for Dual-Battery Systems

Table 4. Status Bits

MODE	STATUS	BATSTAT	ACPRES
All	V _{DD} Undervoltage Lockout	1	1
Startup States		1	1
Standard Battery States	Selected Battery Discharge Path Connected	BATSEL	1
Standard Battery States	Other Battery Discharge Path Connected	$\overline{\text{BATSEL}}$	1
AC Adapter States	Selected Battery Charge Path Connected	BATSEL	0
AC Adapter States	Selected Battery Absent	$\overline{\text{BATSEL}}$	0

If BATSEL is returned to its original state within the BATSEL Action Delay, then changes to the connection states are never made. Note that in the Standard Battery States mode and in the AC Adapter States mode when one or both batteries are present, both BATSTAT and the connection states are delayed during the BATSEL Update Delay.

MOSFET Drivers

To minimize the time when no supply is connected to the external load during switchover transients, the MAX1773/MAX1773A use active pullup drivers for the discharge paths (DIS₋) and the common paths (COM₋). When the MAX1773/MAX1773A initially begin to pull up one of these pins, they use a large current (Initial COM₋ Source Current and Initial DIS₋ Source Current; see *Electrical Characteristics*). Once the COM₋ voltage rises to within 2V of V_{BAT-} or the DIS₋ voltage rises to within 2V of V_{EXTLD}, then a weaker driver is used to hold up the voltage (Final COM₋ Source Current and Final DIS₋ Source Current; see *Electrical Characteristics*).

The MAX1773/MAX1773A are designed to prevent shoot-through from one battery to the other when transitioning from discharging one battery to discharging the other battery. To accomplish this, the MAX1773/MAX1773A do not connect the second battery to EXTLD until it senses that the first battery is disconnected from EXTLD. See Notes 4 and 5 of *Electrical Characteristics*.

To allow flexibility when choosing the higher voltage PDS PMOS FET (P7, Figure 10), the MAX1773/MAX1773A do not limit the gate-to-source voltage applied to the PDS PMOSFET. The minimum V_{GS} is set by the MAX1773/MAX1773A PDS sink current (see *Electrical Characteristics*) and the external resistor from PDS to EXTLD (R13):

$$V_{GS(MIN)} = -I_{PDS(SINK)} \times R_{PDS}$$

where V_{GS(MIN)} is the minimum P7 gate-to-source voltage, I_{PDS(SINK)} is the PDS sink current, and R_{PDS} is R13.

The MAX1773/MAX1773A use open-collector drivers to open the charge paths. Minimize the value of the pullup resistors on the charge paths (R12 and R14) to allow the MAX1773/MAX1773A to quickly turn on the PMOS FETs; however, keep the value large enough to prevent a lower V_{GS} than specified by the PMOS FET. The minimum V_{GS} is:

$$V_{GS(MIN)} = -I_{CHG-(SINK)} \times R_{CHG-}$$

where V_{GS(MIN)} is the minimum P1 or P4 gate-to-source voltage, I_{CHG-(SINK)} is the CHG₋ sink current (see *Electrical Characteristics*), and R_{CHG-} is R12 or R14.

VDD Regulator

The MAX1773/MAX1773A feature an internal linear regulator to provide power for itself and external circuitry. The linear regulator's output is available at V_{DD} and is nominally 3.3V. When the linear regulator is not used to power external circuitry, bypass it with a 0.33μF ceramic capacitor. To supply external loads up to 1mA, bypass the linear regulator with a 3.3μF tantalum capacitor.

Applications Information

Load Switchover Transients

When power switches from one power source to another, a transient is created on the load. This transient (ΔV_{EXTLD}) is minimized by the capacitance on the load (C_{EXTLD}). The voltage transient can be approximated as:

$$\Delta V_{EXTLD} = \frac{i_{EXTLD} \times t_{SWITCHOVER}}{C_{EXTLD}}$$

where t_{SWITCHOVER} is the time where no supply is connected to the EXTLD.

Power Source Selector for Dual-Battery Systems

MAX1773/MAX1773A

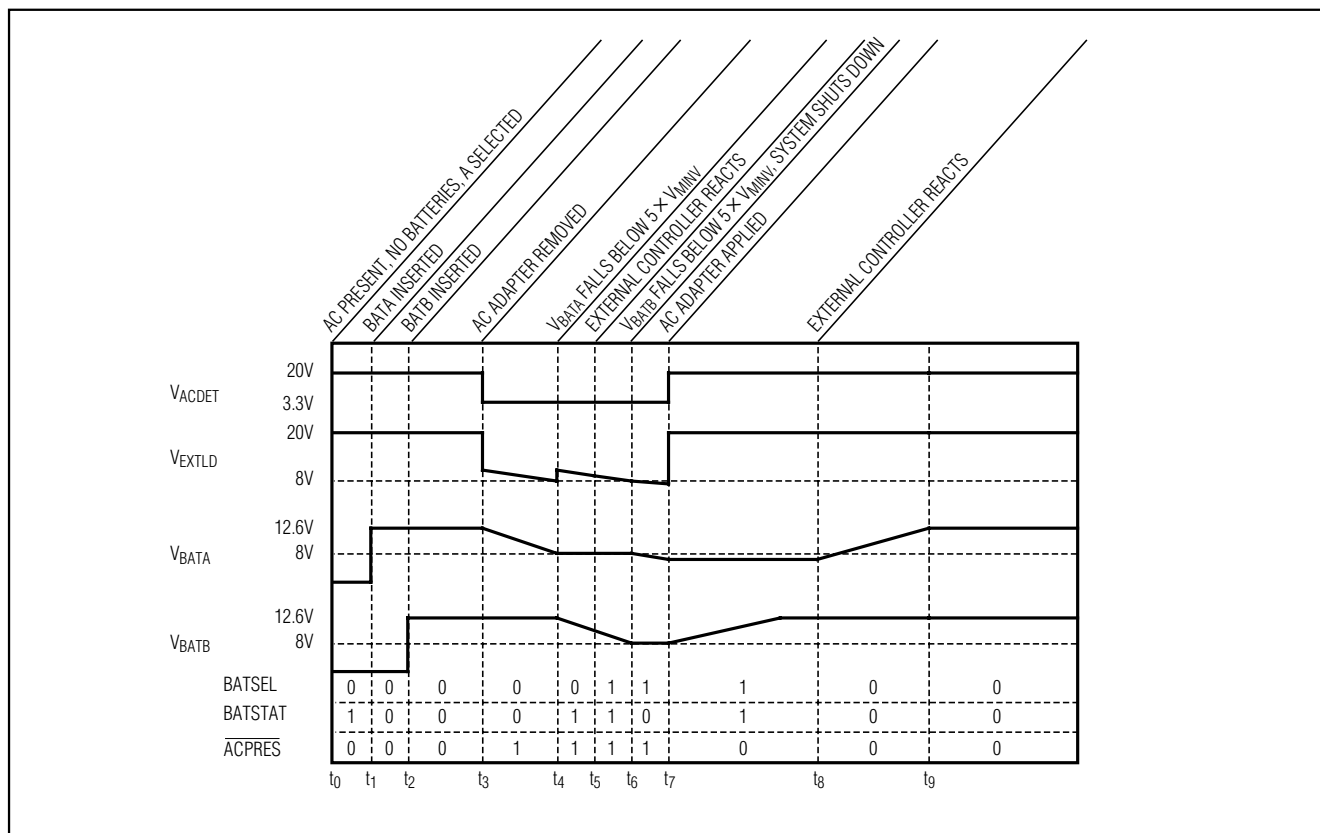

Figure 12. Charge/Discharge Example

In applications where the battery voltage always falls away slowly, $t_{\text{SWITCHOVER}}$ is primarily composed of the Battery Switchover Delay. However, in applications where the battery voltage can suddenly fall away, $t_{\text{SWITCHOVER}}$ is substantially increased because it is primarily composed of the Battery Action Delay (Figures 1 and 2).

Ideally, when a battery is removed from the system, the thermistor connection is broken before the battery's power path is broken. In this case, $t_{\text{SWITCHOVER}}$ is typically bound by the Thermistor Action Delay (Figures 3 and 4). However, if the battery's power path is broken first, then $t_{\text{SWITCHOVER}}$ primarily consists of the shorter of the following times: time until the thermistor connection is broken plus the Thermistor Action Delay, or the Battery Action Delay.

Source Switchover Transients

When the MAX1773/MAX1773A suddenly switch a power supply to the load, they create a current transient from the source to charge up the capacitance on the load. The peak current drawn is approximated by:

$$I_{\text{PK}} = \frac{\Delta V_{\text{EXTLOAD}}}{R_{\text{SOURCE}} + R_{\text{SWITCH}} + R_{\text{ESR}}}$$

where $\Delta V_{\text{EXTLOAD}}$ is the voltage difference between the supply switched off and the supply switched on, R_{SOURCE} is the source resistance of the power supply switched on, R_{SWITCH} is the $R_{\text{DS(ON)}}$ of the PMOS FETs in the path, and R_{ESR} is the equivalent series resistance of the output capacitance.

The duration of the current transient is determined by R_{SOURCE} , R_{SWITCH} , R_{ESR} , and the output capacitance. Smaller resistances and less output capacitance reduce the transient duration.

Typical Operation

Figure 12 shows a typical discharge and charge cycle for a system utilizing the MAX1773/MAX1773A, two 3-cell lithium-ion (Li+) batteries, and a 20V AC adapter power supply. The diagram starts with the AC adapter applied, no batteries present, and battery A selected (see *AC Adapter States*). $\text{BATSTAT} = \text{BATSEL} = 1$ indicates that battery A is not present and battery A's

Power Source Selector for Dual-Battery Systems

Table 5. Recommended Manufacturers

SUPPLIER	PHONE	FAX
Fairchild	408-822-2000	408-822-2102
IR	310-322-3331	310-322-3332
Siliconix	408-988-8000	408-970-3950

charge path is not connected. If the external controller polled the MAX1773/MAX1773A as described in *Status and Configuration*, then BATSTAT would return $\overline{\text{BATSEL}}$ (0) to indicate that battery B is not present.

At t_1 , battery A is inserted and the MAX1773/MAX1773A connect battery A's charge path. Note that BATSTAT changes to BATSEL (0) to indicate that battery A is present.

At t_2 , battery B is inserted. BATSTAT does not change and still indicates that battery A is present.

At t_3 , the AC adapter is removed and the MAX1773/MAX1773A automatically disconnect battery A's charge path and connect battery A's discharge path (see *Standard Battery States*). $\overline{\text{ACPRES}}$ changes to 1 to indicate that the AC adapter source is no longer present. BATSTAT = BATSEL (0) to indicate that battery A is present and supplying the load. Between t_3 and t_4 , battery A discharges as it supplies the load.

At t_4 , battery A's voltage falls below $5 \times V_{\text{MIN}}$, and the MAX1773/MAX1773A automatically disconnect battery A's discharge path and connect battery B's discharge path. BATSTAT goes to $\overline{\text{BATSEL}}$ (1) to indicate that battery A is no longer supplying the load.

Shortly after BATSTAT goes high, the external controller should catch up to the MAX1773/MAX1773A and change BATSEL. This is shown at t_5 . BATSTAT remains at 1, indicating that battery B is present and supplying the load.

At t_6 , battery B falls below $5 \times V_{\text{MIN}}$, and the MAX1773/MAX1773A automatically disconnect battery B's discharge path and connect battery A's discharge path. BATSTAT changes to $\overline{\text{BATSEL}}$ (0) to indicate that battery B is no longer supplying the load. At this point, the external controller orders a controlled shutdown of the system and drastically reduces the supply current.

At t_7 , the AC adapter supply is reconnected to the system. The MAX1773/MAX1773A automatically disconnect battery A's discharge path, connects the AC adapter's load path (PDS switch), and connects battery B's charge path. BATSTAT goes to BATSEL (1) to indicate that battery B is present. $\overline{\text{ACPRES}}$ goes to 0 to indicate that the AC adapter source is present.

At t_8 , the external controller recognizes that battery B is charged and changes BATSEL to battery A. BATSTAT goes to BATSEL (0) to indicate that battery A is present.

After t_9 , the batteries are fully charged and the system is ready for another cycle.

Power MOSFET Selection

The MAX1773/MAX1773A do not place stringent requirements on the external PMOS FETs. Use PMOS FETs with low V_{GS} thresholds (logic level FETs). Low $R_{\text{DS(ON)}}$ PMOS FETs are desirable since the PMOS FET's resistance directly contributes to power losses. Also, ensure that the PMOS FET's V_{DS} and V_{GS} ratings exceed the specific circuit requirements. See Table 5 for a list of recommended manufacturers.

Layout Guidelines

The MAX1773/MAX1773A do not use fast switching times or high frequencies. Therefore, the layout requirements are minimal. Keep the gate connections to the external PMOS FETs short to minimize capacitive coupling, reduce parasitic inductance, and ensure stability. In addition, minimize the power path length when possible to reduce the path's resistance. See the MAX1773 evaluation kit for a layout example.

Pin Configuration

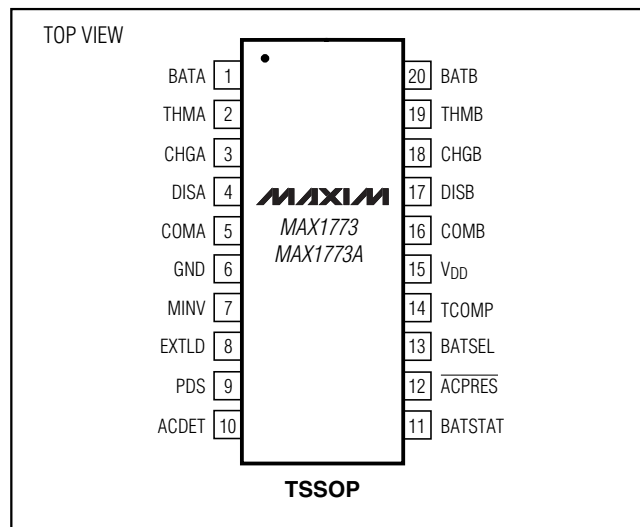

Chip Information

TRANSISTOR COUNT: 5245

PROCESS: BiCMOS

Power Source Selector for Dual-Battery Systems

Differences Between MAX1773 and MAX1773A

This section discusses the differences between the MAX1773 and MAX1773A for the situations detailed. Note that the MAX1773 and MAX1773A are pin-to-pin compatible.

PDS FET Switching

MAX1773: If battery B is selected but absent, and battery A is inserted with a voltage less than five times MINV, when an adapter is inserted, the PDS FET does not turn on. The problem also occurs if battery A is selected but absent, and battery B is inserted with a voltage less than five times MINV, when an adapter is inserted, the PDS FET does not turn on.

In the MAX1773A, when the sequences discussed are encountered, the part has been changed to enable the PDS FET. This results in the PDS FET having to dissipate less energy in the MAX1773A.

Selected Battery Present But Under-Voltage

MAX1773: When the selected battery is present and less than five times the MINV voltage, and a battery above five times the MINV voltage is inserted at the nonselected slot. In this case, the MAX1773 will not enable discharge from the nonselected slot if the THM_ pin of the nonselected battery is valid after the TCOMP pin goes high.

In the MAX1773A the order in which the THM_ and TCOMP pins become enabled is unimportant for these states. This results in this behavior not being encountered in the MAX1773A.

Switchover to Nonselected Battery Upon Adapter Removal

MAX1773: When the selected battery is present and less than five times MINV, and the nonselected battery

is present and greater than five times MINV. The MAX1773 enables the discharge path from the non-selected battery, which has a voltage greater than five times MINV, which is an expected operation for the part. If the AC adapter is then inserted, the charge path to the selected battery is enabled, this is also expected operation. When the adapter is removed, the MAX1773 does not switch to the nonselected battery, which is the issue.

In the MAX1773A, when the AC adapter is removed in the scenario detailed, three separate conditions are possible:

- 1) A charger is present but does not charge the selected battery. This can happen if the input current-limit feature in the charger has been activated, reducing the charger current to zero. The AC adapter is then removed. In this case the MAX1773A allows discharge from the unselected battery, whose voltage was above $5 \times \text{MINV}$.
- 2) A charger is present and charges the selected battery. The battery is charged sufficiently so that it can support the system load for more than 10ms. (Assuming the typical application circuit with $100\text{k}\Omega$ and $0.1\mu\text{F}$ on the AC adapter input.) When the AC adapter is removed, the MAX1773A correctly allows discharge from the selected battery.
- 3) In the third scenario, the charger charges the selected battery, but before the battery is sufficiently charged to support the system load, the AC adapter is removed. In this case, the MAX1773A does not allow discharge from the unselected battery, whose voltage is above $5 \times \text{MINV}$. The limiting condition is that the battery has to be sufficiently charged to support the system load for 10ms.

Power Source Selector for Dual-Battery Systems

Package Information

(The package drawing(s) in this data sheet may not reflect the most current specifications. For the latest package outline information, go to www.maxim-ic.com/packages.)

TOP VIEW

BOTTOM VIEW

SIDE VIEW

END VIEW

DETAIL A

LEAD TIP DETAIL

Symbol	COMMON DIMENSIONS			
	MILLIMETERS		INCHES	
	MIN.	MAX.	MIN.	MAX.
A	—	1.10	—	.043
A ₁	0.05	0.15	.002	.006
A ₂	0.85	0.95	.033	.037
b	0.19	0.30	.007	.012
b ₁	0.19	0.25	.007	.010
c	0.09	0.20	.004	.008
c ₁	0.09	0.14	.004	.006
D	SEE VARIATIONS		SEE VARIATIONS	
E	4.30	4.50	.169	.177
e	0.65 BSC		.026 BSC	
H	6.25	6.55	.246	.258
L	0.50	0.70	.020	.028
N	SEE VARIATIONS		SEE VARIATIONS	
α	0°	8°	0°	8°

JEDEC	N	D	VARIATIONS			
			MILLIMETERS		INCHES	
			MIN.	MAX.	MIN.	MAX.
AB-1	14	D	4.90	5.10	.193	.201
AB	16	D	4.90	5.10	.193	.201
AC	20	D	6.40	6.60	.252	.260
AD	24	D	7.70	7.90	.303	.311
AE	28	D	9.60	9.80	.378	.386

TSSOP4-40mm.EPS

NOTES:

- DIMENSIONS D AND E DO NOT INCLUDE FLASH
- MOLD FLASH OR PROTRUSIONS NOT TO EXCEED 0.15mm PER SIDE
- CONTROLLING DIMENSION: MILLIMETER
- MEETS JEDEC OUTLINE MD-153. SEE JEDEC VARIATIONS TABLE
- 'N' REFERS TO NUMBER OF LEADS
- THE LEAD TIPS MUST LIE WITHIN A SPECIFIED ZONE. THIS TOLERANCE ZONE IS DEFINED BY TWO PARALLEL PLANES. ONE PLANE IS THE SEATING PLANE, DATUM [-C-]; THE OTHER PLANE IS AT THE SPECIFIED DISTANCE FROM [-C-] IN THE DIRECTION INDICATED

DALLAS SEMICONDUCTOR		
PROPRIETARY INFORMATION		
TITLE:		
PACKAGE OUTLINE, TSSOP 4.40mm BODY		
APPROVAL	DOCUMENT CONTROL NO.	REV.
	21-0066	F 1/1

Maxim cannot assume responsibility for use of any circuitry other than circuitry entirely embodied in a Maxim product. No circuit patent licenses are implied. Maxim reserves the right to change the circuitry and specifications without notice at any time.

20 **Maxim Integrated Products, 120 San Gabriel Drive, Sunnyvale, CA 94086 408-737-7600**