

# High-Voltage, 100mA/200mA Adjustable Linear High-Brightness LED Drivers with PWM Dimming

## General Description

The MAX16815/MAX16828 current regulators operate from a 6.5V to 40V input voltage range and deliver up to 100mA (MAX16815) or 200mA (MAX16828) to high-brightness LED (HB LED) loads. The output current is adjusted by using an external current-sense resistor in series with the LEDs. The MAX16815/MAX16828's dimming input allows wide-range "pulsed" PWM operation. An on-board pass element minimizes external components while providing  $\pm 3.5\%$  output-current accuracy.

The MAX16815/MAX16828 are available in a thermally enhanced, 3mm x 3mm, 6-pin TDFN package with exposed pad and in an 8-pin SO package with exposed pad; they are specified over the automotive -40°C to +125°C temperature range.

## Applications

Automotive Interior: Map, Courtesy, and Cluster Lighting  
Automotive Exterior: Rear Combination Lights (RCLs)  
Emergency Vehicle Warning Lights  
Signage and Indicators  
Ambient and Architectural Lighting  
LED Bulbs  
Display Backlighting

Pin Configurations appear at end of data sheet.

## Typical Operating Circuit

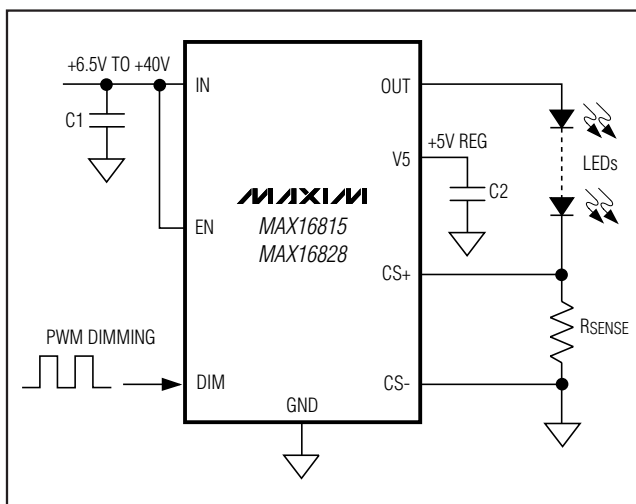

## Simplified Diagram

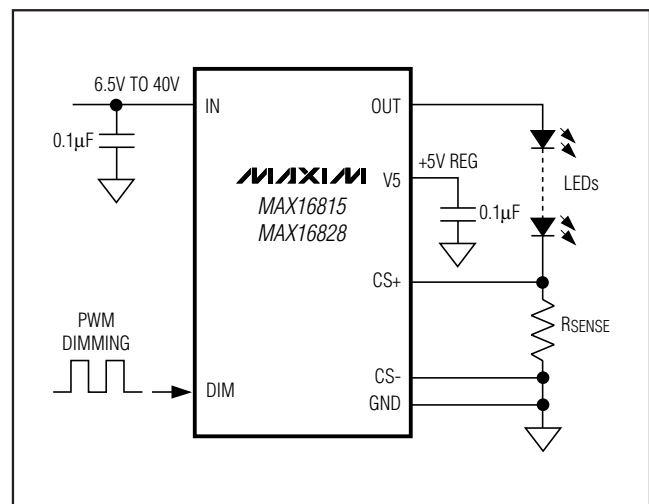

## Features

- ◆ 6.5V to 40V Operating Range
- ◆ Adjustable LED Current
  - MAX16815: 35mA to 100mA
  - MAX16828: 35mA to 200mA
- ◆  $\pm 3.5\%$  LED Current Accuracy
- ◆ High-Voltage DIM Input for Dimming Interface
- ◆ Integrated Pass Element with Low-Dropout Voltage (0.4V typ)
- ◆ 5V Regulated Output with 4mA Source Capability
- ◆ Thermal Shutdown
- ◆ Output Short-Circuit Protection
- ◆ Available in Small, Thermally Enhanced, 3mm x 3mm, 6-Pin TDFN and 8-Pin SO with Exposed Pad Packages
- ◆ -40°C to +125°C Operating Temperature Range

## Ordering Information

PART	TEMP RANGE	PIN-PACKAGE
MAX16815ATT+	-40°C to +125°C	6 TDFN-EP*
MAX16815ASA+	-40°C to +125°C	8 SO-EP*
MAX16828ATT+	-40°C to +125°C	6 TDFN-EP*
MAX16828ASA+	-40°C to +125°C	8 SO-EP*

+Denotes a lead(Pb)-free/RoHS-compliant package.

\*EP = Exposed pad.

# High-Voltage, 100mA/200mA Adjustable Linear High-Brightness LED Drivers with PWM Dimming

## ABSOLUTE MAXIMUM RATINGS

IN to GND .....	-0.3V to +45V	Operating Temperature Range .....	-40°C to +125°C
CS+, CS-, V5 to GND .....	-0.3V to +6V	Junction Temperature .....	+150°C
DIM, EN to GND .....	-0.3V to (V <sub>IN</sub> + 0.3V)	Junction-to-Case Thermal Resistance (θ <sub>JC</sub> ) (Note 1)	
OUT Short Circuited to GND Duration		6-Pin, 3mm x 3mm TDFN .....	9°C/W
(at V <sub>IN</sub> = +16V) .....	60 minutes	8-Pin SO .....	7°C/W
Maximum Current into Any Pin (except IN and OUT) .....	±20mA	Junction-to-Ambient Thermal Resistance (θ <sub>JA</sub> ) (Note 1)	
Continuous Power Dissipation (T <sub>A</sub> = +70°C)		6-Pin, 3mm x 3mm TDFN .....	42°C/W
6-Pin, 3mm x 3mm TDFN		8-Pin SO .....	43°C/W
(derate 18.2mW/°C above +70°C) .....	1454.5mW	Storage Temperature Range .....	-60°C to +150°C
8-Pin SO (derate 23.3mW/°C above +70°C) .....	1860.5mW	Lead Temperature (soldering, 10s) .....	+300°C

**Note 1:** Package thermal resistances were obtained using the method described in JEDEC specification JESD51-7, using a four-layer board. For detailed information on package thermal considerations, refer to [www.maxim-ic.com/thermal-tutorial](http://www.maxim-ic.com/thermal-tutorial).

Stresses beyond those listed under "Absolute Maximum Ratings" may cause permanent damage to the device. These are stress ratings only, and functional operation of the device at these or any other conditions beyond those indicated in the operational sections of the specifications is not implied. Exposure to absolute maximum rating conditions for extended periods may affect device reliability.

## ELECTRICAL CHARACTERISTICS

(V<sub>IN</sub> = 12V, V<sub>EN</sub> = 12V (SO only), C<sub>V5</sub> = 0.1μF to GND, I<sub>V5</sub> = 0, V<sub>DIM</sub> = 4V, V<sub>CS-</sub> = 0V (SO only), connect R<sub>SENSE</sub> = 2Ω (MAX16815) and R<sub>SENSE</sub> = 1Ω (MAX16828) between CS+ and GND. T<sub>A</sub> = -40°C to +125°C, unless otherwise noted. Typical values are at T<sub>A</sub> = +25°C.) (Note 2)

PARAMETER	SYMBOL	CONDITIONS	MIN	TYP	MAX	UNITS
Supply Voltage Range	V <sub>IN</sub>	(Note 3)	6.5		40.0	V
Ground Current	I <sub>G</sub>	I <sub>LOAD</sub> = 100mA		0.82	2	mA
		I <sub>LOAD</sub> = 200mA		1	2	
Shutdown Supply Current	I <sub>SHDN</sub>	V <sub>EN</sub> ≤ 0.6V (SO only)		35	70	μA
Guaranteed Output Current	I <sub>OUT</sub>	R <sub>SENSE</sub> = 2Ω (MAX16815)	100			mA
		R <sub>SENSE</sub> = 1Ω (MAX16828)	200			
Output Current Accuracy		35mA < I <sub>OUT</sub> < 100mA (MAX16815)		±3.5		%
		35mA < I <sub>OUT</sub> < 200mA (MAX16828)		±3.5		
Dropout Voltage	ΔV <sub>DO</sub>	I <sub>OUT</sub> = 100mA (current pulsed), 12V < V <sub>IN</sub> < 40V (MAX16815) (Note 4)		0.1	0.4	V
		I <sub>OUT</sub> = 100mA (current pulsed), 6.5V < V <sub>IN</sub> < 12V (MAX16815) (Note 4)		0.1	0.6	
		I <sub>OUT</sub> = 200mA (current pulsed), 12V < V <sub>IN</sub> < 40V (MAX16828) (Note 5)		0.27	0.55	
		I <sub>OUT</sub> = 200mA (current pulsed), 6.5V < V <sub>IN</sub> < 12V (MAX16828) (Note 5)		0.27	0.7	
Output Current Slew Rate		Current rising		9.7		mA/μs
		Current falling		9.7		
Short-Circuit Current		V <sub>OUT</sub> = 0V, V <sub>IN</sub> = 12V, MAX16815	130	200	270	mA
		V <sub>OUT</sub> = 0V, V <sub>IN</sub> = 12V, MAX16828	250	300	350	
<b>EN INPUT (SO ONLY)</b>						
EN Input Current	I <sub>EN</sub>		-2.5	-1	-0.2	μA
EN Input-Voltage High	V <sub>IH</sub>		2.8			V
EN Input-Voltage Low	V <sub>IL</sub>				0.6	V

# High-Voltage, 100mA/200mA Adjustable Linear High-Brightness LED Drivers with PWM Dimming

MAX16815/MAX16828

## ELECTRICAL CHARACTERISTICS (continued)

( $V_{IN} = 12V$ ,  $V_{EN} = 12V$  (SO only),  $C_{V5} = 0.1\mu F$  to GND,  $I_{V5} = 0$ ,  $V_{DIM} = 4V$ ,  $V_{CS-} = 0V$  (SO only), connect  $R_{SENSE} = 2\Omega$  (MAX16815) and  $R_{SENSE} = 1\Omega$  (MAX16828) between CS+ and GND.  $T_A = -40^\circ C$  to  $+125^\circ C$ , unless otherwise noted. Typical values are at  $T_A = +25^\circ C$ .) (Note 2)

PARAMETER	SYMBOL	CONDITIONS	MIN	TYP	MAX	UNITS
<b>CURRENT SENSE</b>						
Regulated R <sub>SENSE</sub> Voltage	V <sub>RSNS</sub>	V <sub>RSNS</sub> = V <sub>CS+</sub> for TDFN package; V <sub>RSNS</sub> = V <sub>CS+</sub> - V <sub>CS-</sub> for SO package	193	200	207	mV
CS- Voltage Range		SO only	-0.3		+4.7	V
Input Current (CS+)		V <sub>CS+</sub> = 220mV		2.7	7	$\mu A$
Input Current (CS-)		V <sub>CS+</sub> = 220mV (SO only)	-50	17.2		$\mu A$
DIM Input Current		V <sub>DIM</sub> = 0V	-2.5	-1.0	-0.2	$\mu A$
DIM Input-Voltage High	V <sub>IH</sub>		2.8			V
DIM Input-Voltage Low	V <sub>IL</sub>				0.6	V
Turn-On Time	t <sub>ON</sub>	After V <sub>DIM</sub> rising to 4V (Note 7)			100	$\mu s$
Turn-Off Time	t <sub>OFF</sub>	After V <sub>DIM</sub> falling to 0.6V (Note 7)			55	$\mu s$
<b>THERMAL OVERLOAD</b>						
Thermal-Shutdown Temperature				+159		$^\circ C$
Thermal-Shutdown Hysteresis				24		$^\circ C$
<b>+5V REGULATOR</b>						
Output-Voltage Load Regulation	V <sub>V5</sub>	(Note 8)	4.8	5.0	5.2	V
Output Voltage	$\Delta V_{V5}$	0 < I <sub>V5</sub> < 4mA		12	20	mV/mA
V5 Short-Circuit Current		V <sub>V5</sub> = 0 (Note 9)		15		mA

**Note 2:** All devices are 100% production tested at  $T_A = +25^\circ C$ . Limits over the operating temperature range are guaranteed by design.

**Note 3:** Resistors were added from OUT to CS+ to aid with power dissipation.

**Note 4:** Dropout is measured as follows:

Connect R<sub>O</sub> from OUT to CS+. Connect R<sub>SENSE</sub> = 2 $\Omega$  (MAX16815) from CS+ to GND (for TDFN) or from CS+ to CS- (for SO). Set V<sub>IN</sub> = 12V (record V<sub>OUT1</sub> = V<sub>OUT</sub>). For V<sub>IN</sub> = 40V, use R<sub>O</sub> = 360 $\Omega$ ; for V<sub>IN</sub> = 6.5V, use R<sub>O</sub> = 56 $\Omega$ . Reduce V<sub>IN</sub> until V<sub>OUT</sub> = 0.97 x V<sub>OUT1</sub> (record as V<sub>IN2</sub> and V<sub>OUT2</sub>).  $\Delta V_{DO} = V_{IN2} - V_{OUT2}$ .

**Note 5:** Dropout is measured as follows:

Connect R<sub>O</sub> from OUT to CS+. Connect R<sub>SENSE</sub> = 1 $\Omega$  (MAX16828) from CS+ to GND (for TDFN) or from CS+ to CS- (for SO). Set V<sub>IN</sub> = 12V (record V<sub>OUT1</sub> = V<sub>OUT</sub>). For V<sub>IN</sub> = 40V, use R<sub>O</sub> = 180 $\Omega$ ; for V<sub>IN</sub> = 6.5V, use R<sub>O</sub> = 27 $\Omega$ . Reduce V<sub>IN</sub> until V<sub>OUT</sub> = 0.97 x V<sub>OUT1</sub> (record as V<sub>IN2</sub> and V<sub>OUT2</sub>).  $\Delta V_{DO} = V_{IN2} - V_{OUT2}$ .

**Note 6:** I<sub>V5</sub> = 0mA.

**Note 7:** t<sub>ON</sub> time includes the delay and the rise time needed for I<sub>OUT</sub> to reach 90% of its final value. t<sub>OFF</sub> time is the time needed for I<sub>OUT</sub> to drop below 10%. See the *Typical Operating Characteristics*. t<sub>ON</sub> and t<sub>OFF</sub> are tested with 100 $\Omega$  (MAX16815) or 51 $\Omega$  (MAX16828) from OUT to CS+.

**Note 8:** Current regulation varies with V5 load (see the *Typical Operating Characteristics*).

**Note 9:** Thermal shutdown does not function if V5 is shorted to ground.

# High-Voltage, 100mA/200mA Adjustable Linear High-Brightness LED Drivers with PWM Dimming

## Typical Operating Characteristics

( $V_{IN} = 12V$ ,  $T_A = +25^\circ C$ , unless otherwise noted.)

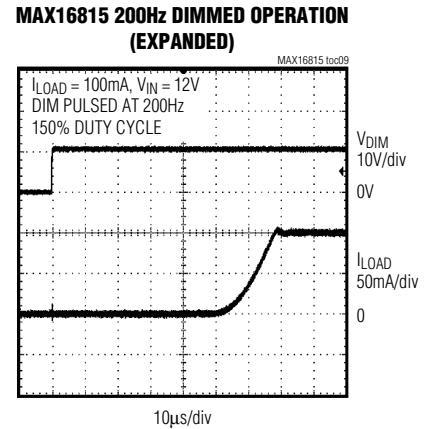
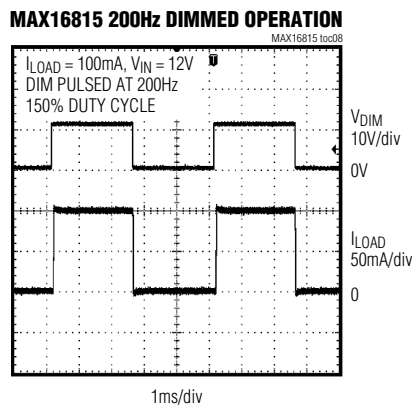
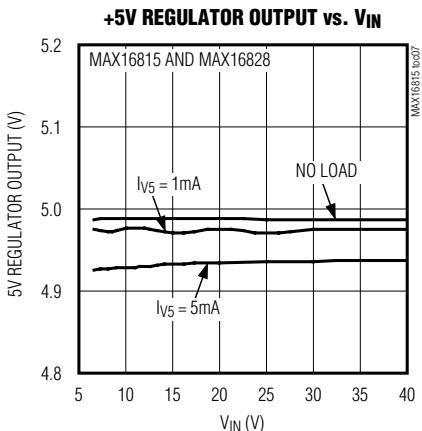
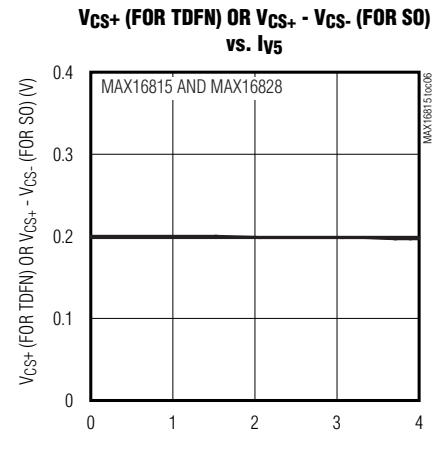
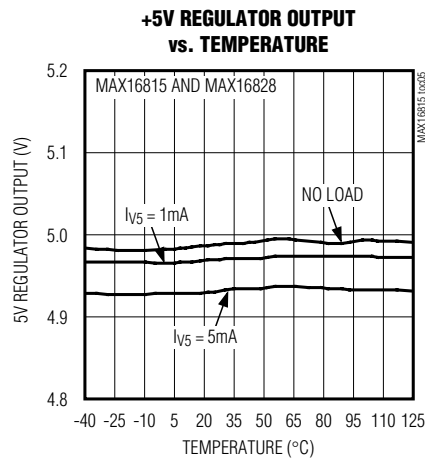
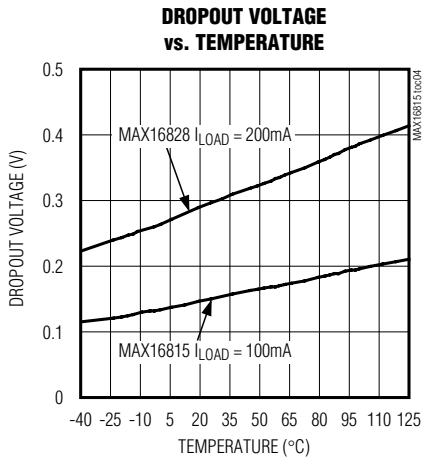
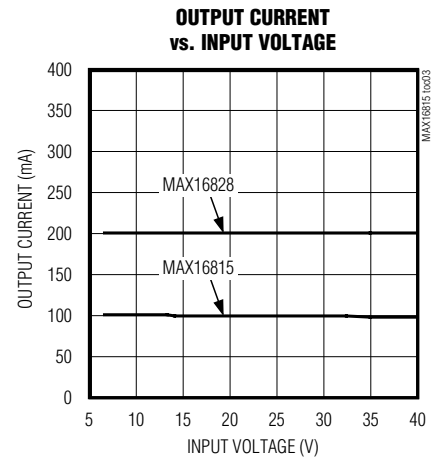
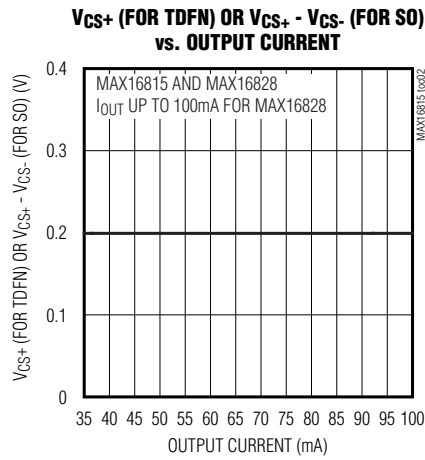
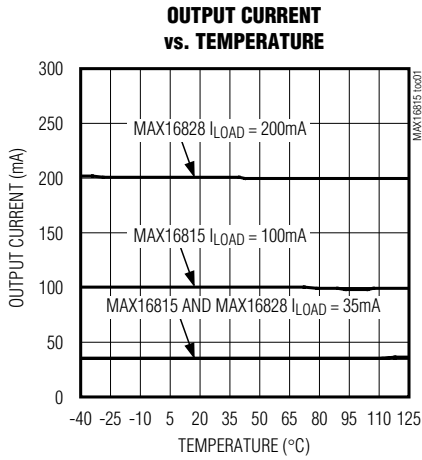

# High-Voltage, 100mA/200mA Adjustable Linear High-Brightness LED Drivers with PWM Dimming

## Typical Operating Characteristics (continued)

( $V_{IN} = 12V$ ,  $T_A = +25^\circ C$ , unless otherwise noted.)

**MAX16815 200Hz DIMMED OPERATION (EXPANDED)**

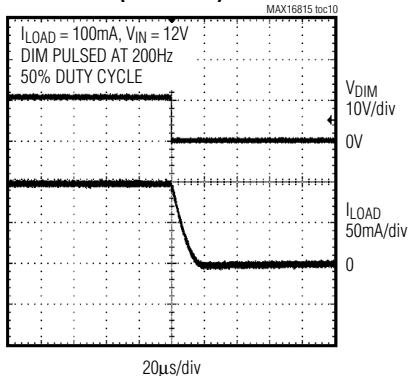

**MAX16828 200Hz DIMMED OPERATION**

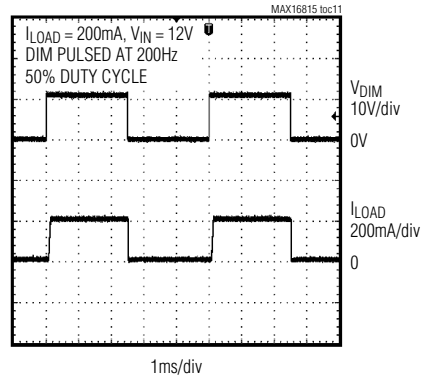

**MAX16828 200Hz DIMMED OPERATION (EXPANDED)**

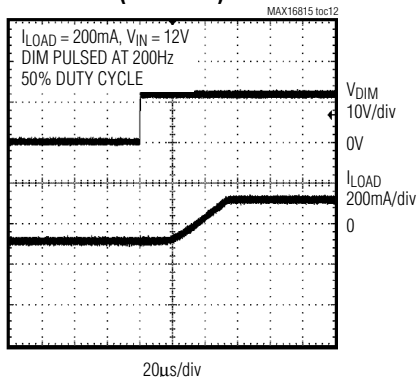

**MAX16828 200Hz DIMMED OPERATION (EXPANDED)**

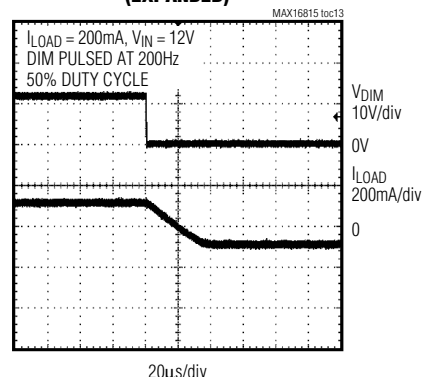

**MAX16815/MAX16828**

# High-Voltage, 100mA/200mA Adjustable Linear High-Brightness LED Drivers with PWM Dimming

## Pin Description

PIN		NAME	FUNCTION
TDFN	SO		
1	6	DIM	Pulsed Dimming Input. Drive DIM low to turn off output current (LED current). Drive DIM high to turn on the output current (LED current). DIM is pulled high to $V_{IN}$ when left unconnected.
—	7	EN	Enable Input. Drive EN high to enable the output. For the TDFN package, this input is not accessible and always high.
2	8	OUT	Current-Regulated Output
3	1	IN	Positive Input Supply. Bypass IN with a 0.1 $\mu$ F (min) capacitor to GND.
4	2	CS+	LED Current-Sense Amplifier Positive Input. For the SO package version, connect the current-sense resistor between this pin and CS-; for the TDFN version, connect it between this pin and ground.
—	3	CS-	LED Current-Sense Amplifier Negative Input. Connect to ground.
5	4	V5	+5V Regulated Output. Connect a 0.1 $\mu$ F (min) capacitor from V5 to GND.
6	5	GND	Ground
—	—	EP	Exposed Pad. Connect to a large ground plane for effective power dissipation. Do not use as the only ground connection.

## TDFN Functional Diagram

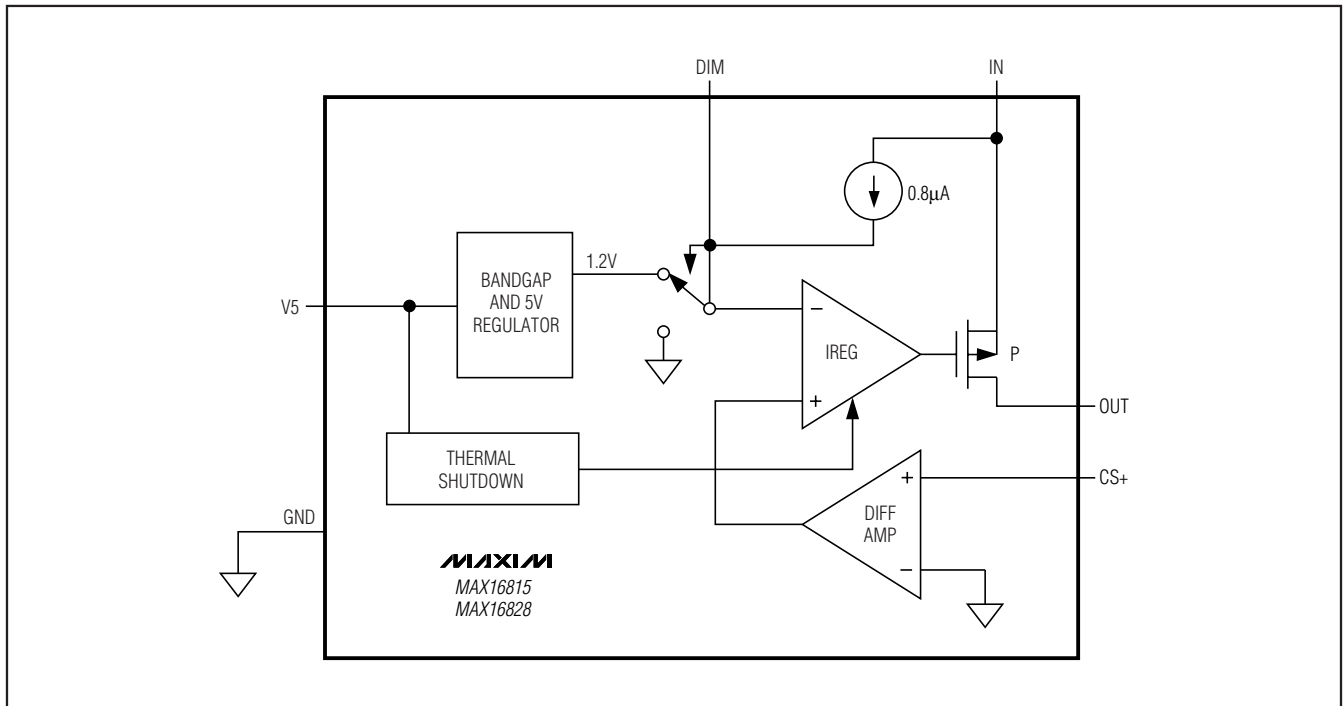

# High-Voltage, 100mA/200mA Adjustable Linear High-Brightness LED Drivers with PWM Dimming

## SO Functional Diagram

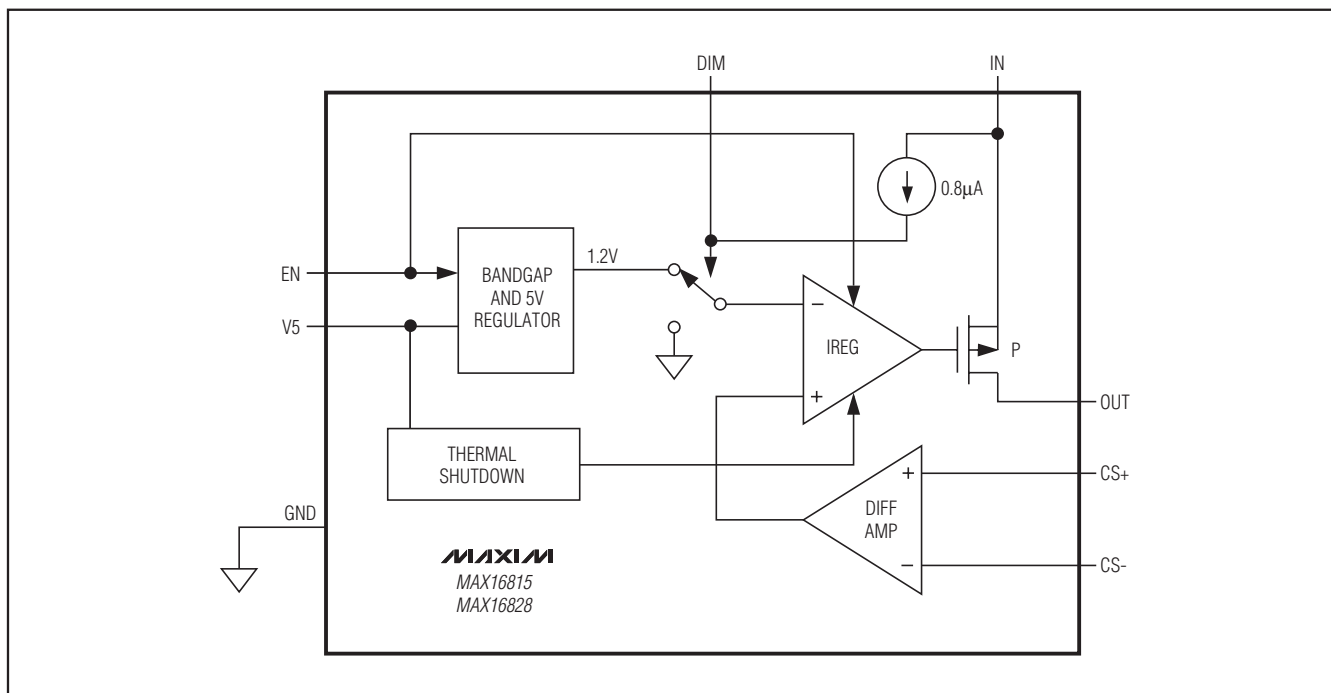

MAX16815/MAX16828

## Detailed Description

### +5V Regulator

The MAX16815/MAX16828 include a fixed +5V output regulator that delivers up to 4mA of load current throughout the 6.5V to 40V input voltage range. Connect a 0.1µF compensation capacitor from V5 to ground. Shorting V5 to ground disables the thermal shutdown. V5 stays on during PWM dimming.

### Thermal Protection

The MAX16815/MAX16828 enter a thermal-shutdown mode in the event of overheating. This typically occurs in overload or output short-circuit conditions. If the junction temperature exceeds  $T_J = +159^{\circ}\text{C}$  (typ), the internal thermal-protection circuitry turns off the series pass device. The MAX16815/MAX16828 recover from thermal-shutdown mode once the junction temperature drops by  $24^{\circ}\text{C}$  (typ). The devices therefore protect themselves by thermal cycling in the event of a short-circuit or overload condition. Shorting V5 to ground disables the thermal shutdown.

## Applications Information

### Programming the LED Current

The MAX16815/MAX16828 use a sense resistor across CS+ and GND for the TDFN package or across CS+ and CS- for the SO package, to set the LED current. The LED current is given by  $I_{LED} = V_{RSNS}/R_{SENSE}$ .

### Input-Voltage Considerations

For proper operation, the minimum input voltage must always be:

$$V_{IN(MIN)} \geq V_{RSNS(MAX)} + V_{FT(MAX)} + \Delta V_{DO(MAX)}$$

where  $V_{FT(MAX)}$  is the total forward voltage of all series connected LEDs. The minimum operating voltage of the device is +6.5V. The device operates below +6.5V; however, output current may not meet the full regulation specification (see the *Typical Operating Characteristics*) and the V5 regulator will drop below 5V.

### Low-Frequency PWM Dimming at the Output

Provide a pulse to the dimming input (DIM) of the MAX16815/MAX16828 to produce a PWM output. Alternatively, connect DIM to IN and pulse IN.

# High-Voltage, 100mA/200mA Adjustable Linear High-Brightness LED Drivers with PWM Dimming

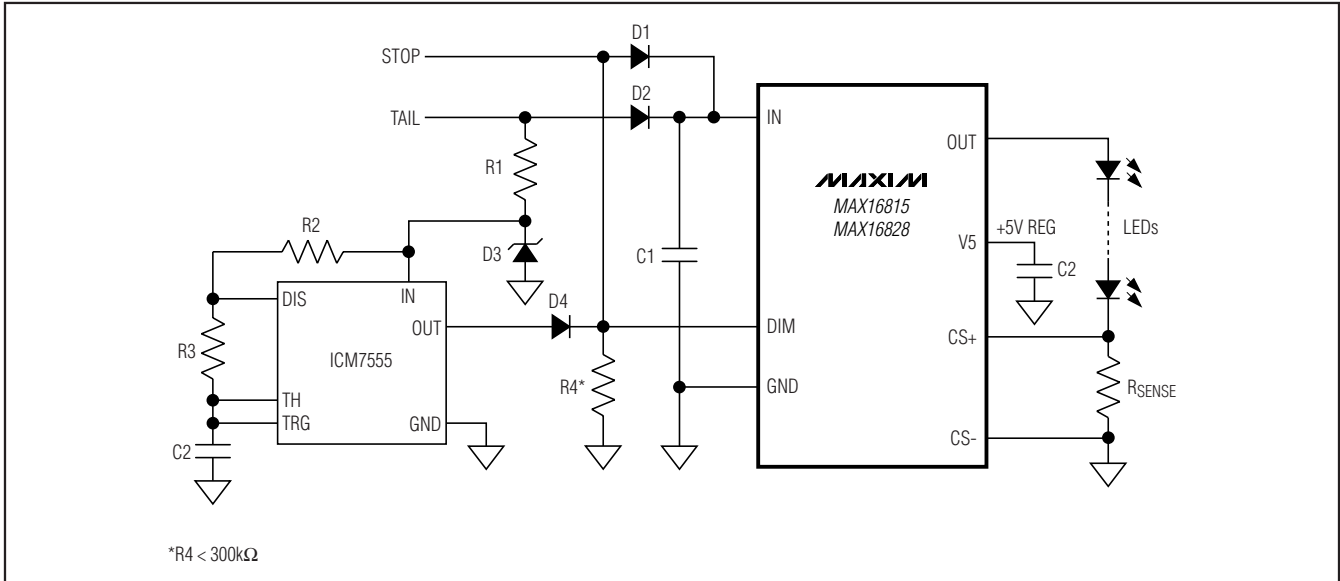

Figure 1. PWM Dimming Operation with ICM7555 Timer

## Two Brightness Levels for TAIL/STOP Lights

Figure 1 shows PWM dimming operation for the MAX16815/MAX16828 with an ICM7555 timer. The ICM7555 provides adjustable duty cycle using two external resistors and a capacitor. In TAIL operation, the output of the ICM7555 feeds into DIM and lights up the LEDs. The LED's brightness depends on the duty cycle of the ICM7555. When  $V_{STOP}$  is present, DIM is pulled up to  $V_{STOP}$ . The PWM dimming operation is disabled and the LEDs light up to full brightness. See the ICM7555 data sheet for formulas to calculate the dimming frequency and the duty cycle.

## LED Current Thermal Foldback

With a minimum number of external components, the MAX16815/MAX16828 provide LED current thermal foldback using a negative temperature coefficient (NTC) thermistor. Figure 2 shows a thermistor connected to V5 and the CS+ of the MAX16815/MAX16828. As the temperature increases, the voltage drop across R2 increases, causing the LED current to decrease.

$$I_{LED} = [V_{RSNS} - (R2 / R_T) (V_{V5} - V_{RSNS})] / R1$$

## Other Applications

The application circuit in Figure 3 implements a two-level brightness current for TAIL/STOP lights. In TAIL operation, Q1 is off and R1 sets the output current. In

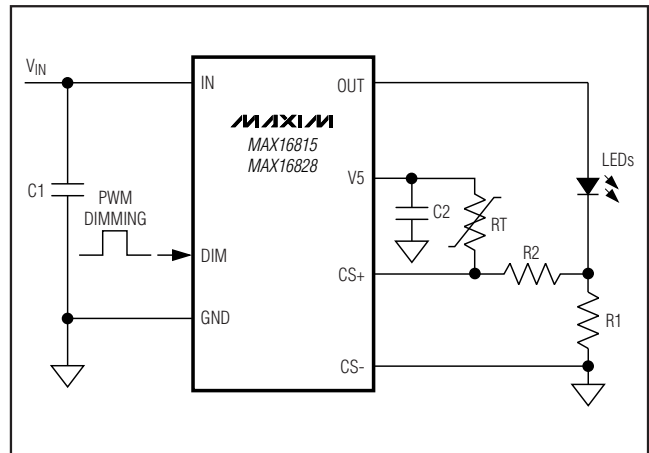

Figure 2. LED Current Thermal Foldback with an NTC Thermistor

STOP operation, Q1 turns on and the output current is set by a parallel combination of R1 and R2. Figure 4 shows an application circuit with the MAX16815/MAX16828 using a single BJT to provide high output current. For proper operation:

$$V_{IN(MIN)} > V_{CESAT(MAX)} + V_{FT(MAX)} + V_{RSNS}$$

where  $V_{CESAT(MAX)}$  is the maximum saturation voltage of the external BJT and  $V_{FT(MAX)}$  is the total forward voltage of all series connected LEDs.



# High-Voltage, 100mA/200mA Adjustable Linear High-Brightness LED Drivers with PWM Dimming

**MAX16815/MAX16828**

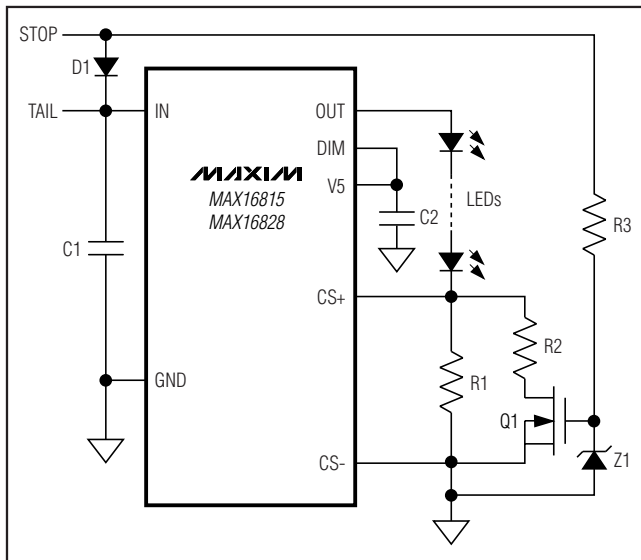

Figure 3. Two-Level Brightness with Current Level Switch for TAIL/STOP Lights

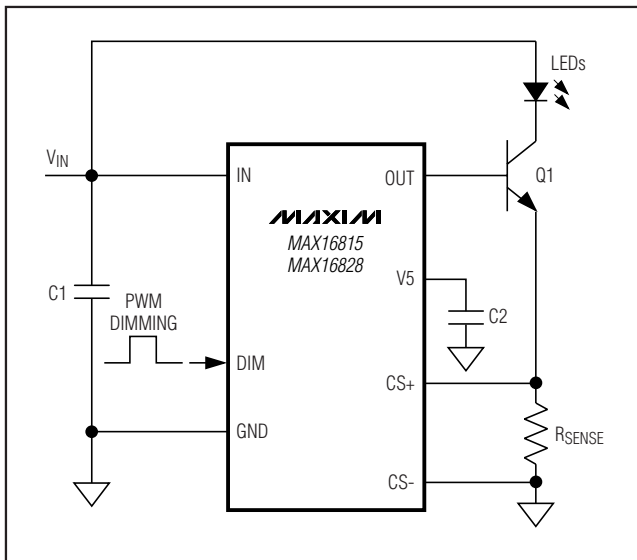

Figure 4. Increased LED Current (Ampere Range) with a Single BJT

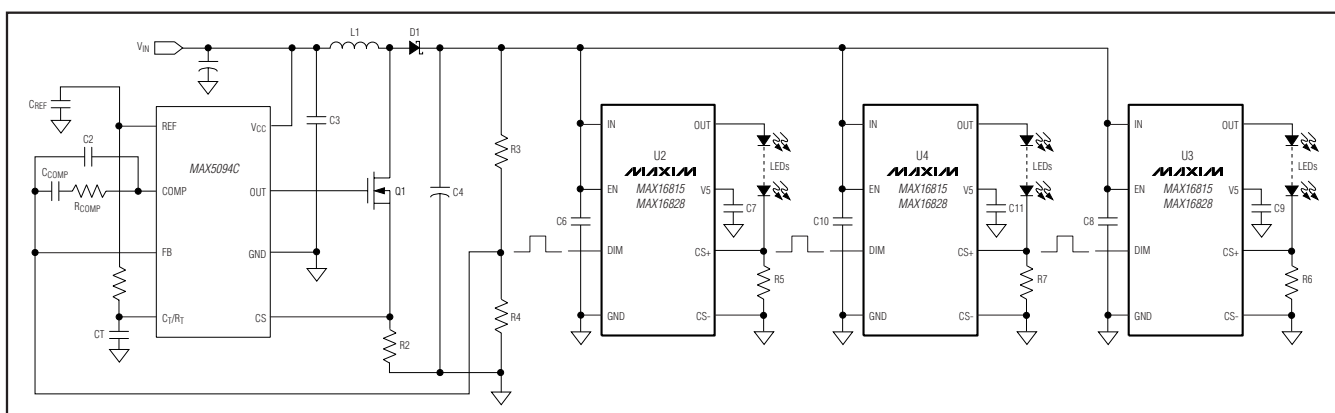

Figure 5. Multichannel HB LED Drivers for LCD Backlight

## Multichannel HB LED Driver

Figure 5 shows an array of MAX16815/MAX16828s with independent DIM control. The MAX5094C, a current-mode PWM controller, provides the input power to each LED driver preregulated voltage to multiple MAX16815/MAX16828 drivers.

## Chip Information

PROCESS: BiCMOS

# High-Voltage, 100mA/200mA Adjustable Linear High-Brightness LED Drivers with PWM Dimming

## Pin Configurations

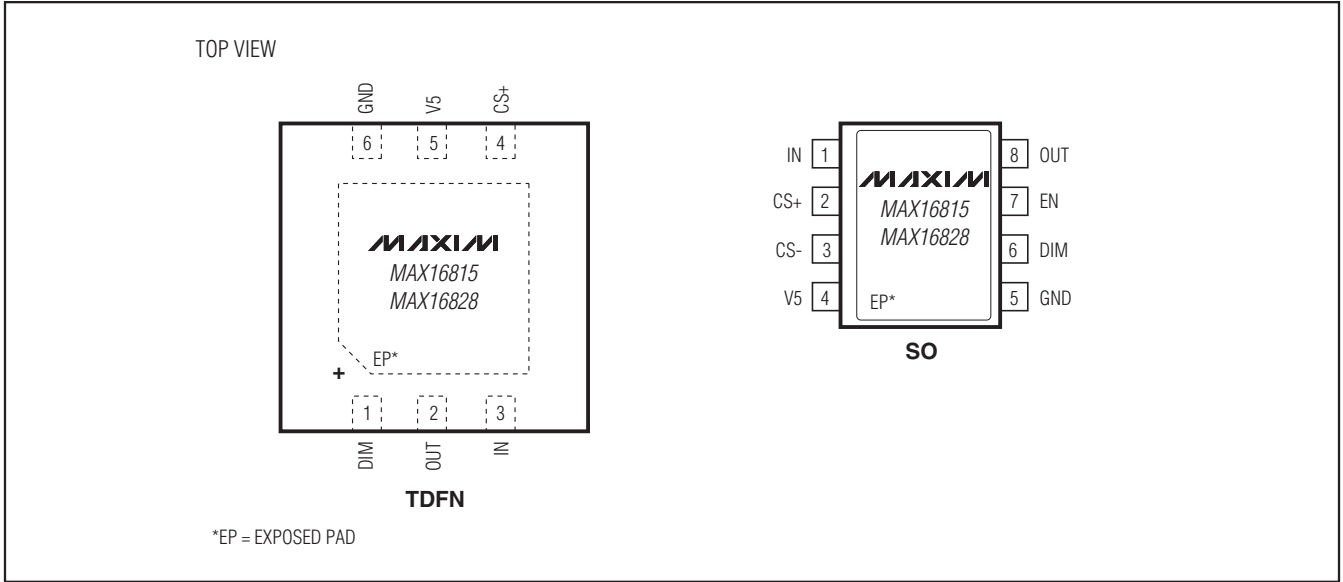

## Package Information

For the latest package outline information and land patterns, go to [www.maxim-ic.com/packages](http://www.maxim-ic.com/packages).

PACKAGE TYPE	PACKAGE CODE	DOCUMENT NO.
8 SO-EP	S8E-12	<a href="#">21-0111</a>
6 TDFN-EP	T633-2	<a href="#">21-0137</a>

# High-Voltage, 100mA/200mA Adjustable Linear High-Brightness LED Drivers with PWM Dimming

## Revision History

REVISION NUMBER	REVISION DATE	DESCRIPTION	PAGES CHANGED
0	2/08	Initial release.	—
1	7/09	<ul style="list-style-type: none"><li>Added the SO package to the <i>Ordering Information</i> table, <i>Electrical Characteristics</i>, <i>TOC 2 and 6</i>, <i>Pin Description</i> table, and <i>Functional Diagrams</i>.</li><li>Modified the <i>Simplified Diagram</i> and <i>Figures 1–4</i> to include the CS- pin.</li><li>Added the <i>SO-EP Pin Configuration</i>.</li></ul>	1–4, 6–10

MAX16815/MAX16828

Maxim cannot assume responsibility for use of any circuitry other than circuitry entirely embodied in a Maxim product. No circuit patent licenses are implied. Maxim reserves the right to change the circuitry and specifications without notice at any time.

Maxim Integrated Products, 120 San Gabriel Drive, Sunnyvale, CA 94086 408-737-7600 \_\_\_\_\_ 11