

MAX14508E–MAX14511E/ MAX14509AE

USB 2.0 Hi-Speed and Audio Switches with Negative Signal Capability

General Description

The MAX14508E–MAX14511E/MAX14509AE high-ESD-protected DPDT switches multiplex Hi-Speed (480Mbps) USB and analog signals such as AC-coupled audio or video. These devices combine the low on-capacitance (C_{ON}) and low on-resistance (R_{ON}) necessary for high-performance switching applications in portable electronics, and include an internal negative supply to pass audio signals that swing below ground (down to $V_{CC} - 5.0V$). The MAX14508E–MAX14511E/MAX14509AE also handle USB low-/full-speed signaling and operate from a +2.7V to +5.0V supply.

The MAX14508E–MAX14511E feature +5.5V fault protection on COM1 and COM2, making these devices compliant with the USB 2.0 fault-protection specification. The MAX14510E/MAX14511E feature a VBUS detection input (VB) to automatically switch to the USB signal path upon detection of a valid VBUS signal. The MAX14508E/MAX14510E feature internal shunt resistors on the audio path to reduce clicks and pops heard at the output. The MAX14508E/MAX14509E/MAX14509AE have an enable input (EN) to reduce supply current and set all channels to high impedance when driven low.

The MAX14508E–MAX14511E/MAX14509AE are available in a space-saving, 10-pin, 1.4mm x 1.8mm UTQFN package, and operate over the $-40^{\circ}C$ to $+85^{\circ}C$ temperature range.

Applications

- Cell Phones
- MP3 Players
- Notebook Computers
- PDAs

Typical Operating Circuit appears at end of data sheet.

Ordering Information/Selector Guide

PART	PIN-PACKAGE	VBUS DETECTION/ ENABLE LINE	FAULT PROTECTION	SHUNT RESISTORS	TOP MARK
MAX14508EEVB+	10 Ultra-Thin QFN	Enable	Yes	Yes	AAH
MAX14509EEVB+*	10 Ultra-Thin QFN	Enable	Yes	No	AAI
MAX14509AEEVB+	10 Ultra-Thin QFN	Enable	No	No	AAL
MAX14510EEVB+	10 Ultra-Thin QFN	VBUS	Yes	Yes	AAJ
MAX14511EEVB+*	10 Ultra-Thin QFN	VBUS	Yes	No	AAK

Note: All devices operate over the $-40^{\circ}C$ to $+85^{\circ}C$ temperature range.

+Denotes a lead(Pb)-free/RoHS-compliant package.

*Future product—contact factory for availability.

Benefits and Features

- Single +2.7V to +5.0V Supply Voltage
- Low 12 μ A Supply Current
- -3dB Bandwidth: 950MHz (typ)
- Low 2.4 Ω (typ) On-Resistance
- Low 20m Ω (typ) R_{ON} Flatness
- THD+N: 0.05%
- COM Analog Inputs Fault Protected Against Shorts to +5.5V (MAX14508E/MAX14509E/MAX14510E/MAX14511E)
- Internal Shunt Resistors for Click-and-Pop Reduction (MAX14508E/MAX14510E)
- VBUS Detection for Automatic Switch Path Selection (MAX14510E/MAX14511E)
- Space-Saving Package: 10-Pin, 1.4mm x 1.8mm UTQFN

Pin Configurations

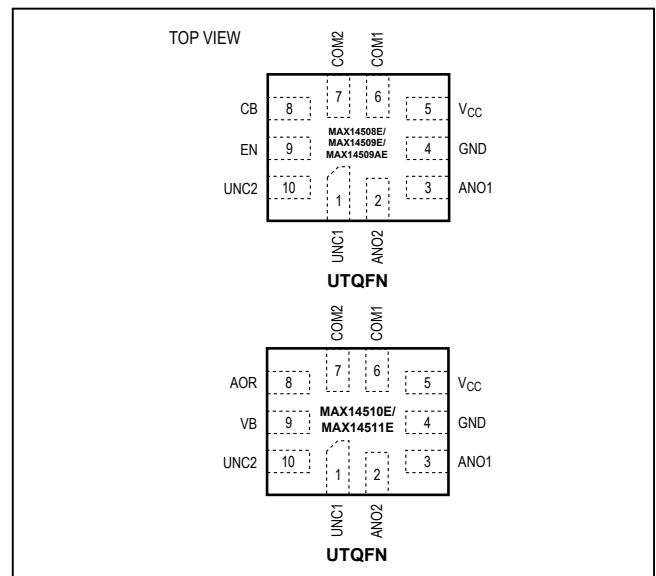

Absolute Maximum Ratings

(Voltages referenced to GND.)

V _{CC} , CB, EN, VB, AOR.....	-0.3V to +6.0V
COM ₋ (V _{EN} > V _{IH}) (Note 1).....	(V _{CC} - 5.0V) to +6.0V
COM ₋ (V _{EN} < V _{IL}).....	-0.3V to +6.0V
ANO ₋ (V _{EN} > V _{IH}).....	(V _{CC} - 5.0V) to (V _{CC} + 0.3V)
ANO ₋ (V _{EN} < V _{IL}).....	-0.3V to (V _{CC} + 0.3V)
UNC ₋	-0.3V to (V _{CC} + 0.3V)
Continuous Current into Any Terminal.....	±100mA
Continuous Power Dissipation (T _A = +70°C)	
10-Pin UTQFN (derate 6.9mW/°C above +70°C)	559mW

Junction-to-Case Thermal Resistance (θ_{JC}) (Note 2)

10-Pin UTQFN.....20.1°C/W

Junction-to-Ambient Thermal Resistance (θ_{JA}) (Note 2)

10-Pin UTQFN.....143.1°C/W

Operating Temperature Range.....-40°C to +85°C

Junction Temperature Range.....-40°C to +150°C

Storage Temperature Range.....-65°C to +150°C

Lead Temperature (soldering, 10s).....+300°C

Note 1: Limits are only for the MAX14508E/MAX14509E/MAX14510E/MAX14511E. For the MAX14509AE (V_{CC} ≥ 2.7V), the limits are from (V_{CC} - 5.0V) to min of 6.0V or (V_{CC} + 1.0V).

Note 2: Package thermal resistances were obtained using the method described in JEDEC specification JESD51-7, using a four-layer board. For detailed information on package thermal considerations, refer to www.maximintegrated.com/thermal-tutorial.

Stresses beyond those listed under "Absolute Maximum Ratings" may cause permanent damage to the device. These are stress ratings only, and functional operation of the device at these or any other conditions beyond those indicated in the operational sections of the specifications is not implied. Exposure to absolute maximum rating conditions for extended periods may affect device reliability.

Electrical Characteristics

(V_{CC} = +2.7V to +5.0V, T_A = -40°C to +85°C, unless otherwise noted. Typical values are at V_{CC} = +3.0V, T_A = +25°C.) (Note 3)

PARAMETER	SYMBOL	CONDITIONS	MIN	TYP	MAX	UNITS
Operating Power-Supply Range	V _{CC}		2.7		5.0	V
Supply Current	I _{CC}	V _{CC} = 3.3V	MAX14508E/MAX14509E/ MAX14509AE, V _{EN} = 0V		1	μA
			(V _{EN} = V _{CC} , V _{CB} = 0V) or (V _{AOR} = 0V, V _{VB} > V _{VBDET})	6	12	
			(V _{EN} = V _{CC} , V _{CB} = V _{CC}) or (V _{AOR} = V _{CC} , V _{VB} = 0V)	6	12	
		V _{CC} = 5.0V	MAX14508E/MAX14509E/ MAX14509AE, V _{EN} = 0V		1	
			(V _{EN} = V _{CC} , V _{CB} = 0V) or (V _{AOR} = 0V, V _{VB} > V _{VBDET})	6	12	
			(V _{EN} = V _{CC} , V _{CB} = V _{CC}) or (V _{AOR} = V _{CC} , V _{VB} = 0V)	6	12	
Power-Supply Rejection Ratio	PSRR	f = 10kHz, V _{CC} = 3.0 ± 0.3V, R _{COM-} = 50Ω		60		dB
COM Overtolerance Detect Threshold	V _{FP}	MAX14508E/MAX14509E/MAX14510E/ MAX14511E, V _{CC} = +2.7V to +3.3V, Figure 1 (Note 4)	V _{CC} + 0.8		V _{CC} + 1.6	V
Fault-Protection Response Time	t _{FP}	V _{COM} = 1V to 5V step, V _{CC} = 3.0V, R _{UNC-} + R _{ANO-} = 1kΩ		1.3	5.0	μs
Fault-Protection Recovery Time	t _{FPR}	V _{COM} = 5V to 1V step, V _{CC} = 3.0V, R _{UNC-} + R _{ANO-} = 1kΩ		2		μs
Analog Signal Range	V _{UNC-}		0		V _{CC}	V
	V _{ANO-} , V _{COM-}	V _{EN} > V _{IH}	V _{CC} - 5.0		V _{CC}	
		V _{EN} < V _{IL}	0		V _{CC}	

Electrical Characteristics (continued)

(V_{CC} = +2.7V to +5.0V, T_A = -40°C to +85°C, unless otherwise noted. Typical values are at V_{CC} = +3.0V, T_A = +25°C.) (Note 3)

PARAMETER	SYMBOL	CONDITIONS	MIN	TYP	MAX	UNITS
ANO_ On-Resistance	R _{ON(ANO_)}	V _{CC} = 3.0V; V _{ANO_} = -1.5V, +1.5V; I _{COM_} = 10mA		2.4	5	Ω
UNC_ On-Resistance	R _{ON(UNC_)}	V _{CC} = 3.0V; V _{UNC_} = 0V, V _{CC} ; I _{COM_} = 10mA		2.4	5	Ω
		MAX14509AE, V _{CC} = 2.7V, V _{COM_} = 3.6V, I _{COM_} = 10mA		2.4	5	
ANO_ On-Resistance Match Between Channels	ΔR _{ON(ANO_)}	V _{CC} = 3.0V, V _{ANO_} = 0V, I _{COM_} = 10mA (Notes 5, 6)			0.2	Ω
UNC_ On-Resistance Match Between Channels	ΔR _{ON(UNC_)}	V _{CC} = 3.0V, V _{UNC_} = 0V, I _{COM_} = 10mA (Notes 5, 6)			0.2	Ω
ANO_ On-Resistance Flatness	R _{FLAT(ANO_)}	V _{CC} = 3.0V, I _{COM_} = 10mA, V _{ANO_} = -1.5V to +1.5V (Note 7)		0.03	0.25	Ω
UNC_ On-Resistance Flatness	R _{FLAT(UNC_)}	V _{CC} = 3.0V, I _{COM_} = 10mA, V _{UNC_} = 0V to V _{CC} (Note 7)		0.05	0.5	Ω
Shunt Switch Resistance	R _{SH}	MAX14508E/MAX14510E, I _{ANO_} = 10mA		100	200	Ω
AOR Pulldown Resistance	R _{AOR}		250		1200	kΩ
UNC_ Off-Leakage Current	I _{UNC_(OFF)}	V _{CC} = 3.0V; V _{UNC_} = +2.5V, 0V; V _{COM_} = -1.5V, +2.5V; V _{EN} = V _{CC} for MAX14508E/MAX14509E/MAX14509AE	-10		+10	nA
ANO_ Off-Leakage Current	I _{ANO_(OFF)}	MAX14509E/MAX14511E/MAX14509AE; V _{CC} = 3.0V; V _{ANO_} = +2.5V, 0V; V _{COM_} = 0V, +2.5V	-10		+10	nA
COM_ Off-Leakage Current	I _{COM_(OFF)}	MAX14508E/MAX14509E/MAX14509AE, V _{CC} = 3.0V, V _{EN} = 0V, V _{COM_} = 3.6V, V _{UNC_} = V _{ANO_} = 0V	-10		+10	μA
		MAX14508E/MAX14509E/MAX14509AE, V _{CC} = 3.3V, V _{EN} = 0V, V _{COM_} = 0V, V _{UNC_} = V _{ANO_} = 0V	-10		+10	nA
		V _{CC} = 0V, V _{COM_} = 3.6V, V _{UNC_} = V _{ANO_} = 0V	10		600	μA
COM_ On-Leakage Current	I _{COM_(ON)}	USB mode V _{CC} = 3.0V; V _{ANO_} = 0V, 2.5V; unconnected; V _{COM_} = 0V, 2.5V	-200		+200	nA
		Audio mode V _{CC} = 3.0V; V _{UNC_} = 0V, 2.5V; unconnected; V _{COM_} = -1.5V, +2.5V	-200		+200	
Turn-On Time (Figure 2)	t _{ON}	ANO_ to COM_, V _{CC} = 3.0V (V _{ANO_} = 1.5V, R _L = 50Ω, V _{EN} = V _{CC} , V _{CB} = 0V to V _{CC}) or (V _{AOR} = 0V, V _{VB} = 5.0V to 0V) or (V _{VB} = 5.0V, V _{AOR} = 0V to V _{CC})		14	60	μs
		UNC_ to COM_, V _{CC} = 3.0V (V _{UNC_} = 1.5V, R _L = 50Ω, V _{EN} = V _{CC} , V _{CB} = V _{CC} to 0V) or (V _{AOR} = 0V, V _{VB} = 0V to 5.0V)		14	60	

Electrical Characteristics (continued)

($V_{CC} = +2.7V$ to $+5.0V$, $T_A = -40^{\circ}C$ to $+85^{\circ}C$, unless otherwise noted. Typical values are at $V_{CC} = +3.0V$, $T_A = +25^{\circ}C$.) (Note 3)

PARAMETER	SYMBOL	CONDITIONS		MIN	TYP	MAX	UNITS
Turn-Off Time (Figure 2)	t_{OFF}	ANO_ from COM_, $V_{CC} = 3.0V$	($V_{ANO_} = 1.5V$, $R_L = 50\Omega$, $V_{EN} = \bar{V}_{CC}$, $V_{CB} = V_{CC}$ to 0V) or ($V_{AOR} = 0V$, $V_{VB} =$ 0V to 5.0V) or ($V_{VB} = 5.0V$, $V_{AOR} = V_{CC}$ to 0V)		1.4	5	μs
		ANO_ from COM_, $V_{CC} = 3.0V$	($V_{UNC_} = 1.5V$, $R_L = 50\Omega$, $V_{EN} = \bar{V}_{CC}$, $V_{CB} = 0V$ to V_{CC}) or ($V_{AOR} = 0V$, V_{VB} $= 5.0V$ to 0V or $V_{VB} = 5.0V$, $V_{AOR} = 0V$ to V_{CC})		0.7	5	
Break-Before-Make Time Delay	t_D	$R_L = 50\Omega$			13.5		μs
Output Skew Same Switch	$t_{SK(P)}$	Figure 3 (Note 5)			40		ps
Output Skew Between Switches	$t_{SK(O)}$	Figure 3 (Note 5)			40		ps
ANO_ Off-Capacitance	$C_{ANO_ (OFF)}$	$V_{COM_} = 0.5V_{P-P}$, DC bias = 0V, $f = 1MHz$ (Note 5)			8		pF
UNC_ Off-Capacitance	$C_{UNC_ (OFF)}$	$V_{COM_} = 0.5V_{P-P}$, DC bias = 0V, $f = 240MHz$ (Note 5)			3.3		pF
On-Capacitance (Note 5)	$C_{COM(ON)}$	UNC_ to COM_, $V_{COM_} = 0.5V_{P-P}$, DC bias = 0V, $f = 240MHz$			8		pF
		ANO_ to COM_, $V_{COM_} = 0.5V_{P-P}$, DC bias = 0V, $f = 1MHz$			8		pF
AC PERFORMANCE							
ANO_ -3dB Bandwidth	$BWA_{NO_}$	$R_S = R_L = 50\Omega$, $V_{ANO_} = 0dBm$, Figure 4			950		MHz
UNC_ -3dB Bandwidth	$BWA_{NC_}$	$R_S = R_L = 50\Omega$, $V_{UNC_} = 0dBm$, Figure 4			950		MHz
Off-Isolation	V_{ISO}	$f = 100kHz$, $V_{COM_} = 1V_{RMS}$, $R_S = R_L = 50\Omega$, Figure 4			-65		dB
Crosstalk	V_{CT}	$f = 100kHz$, $V_{COM_} = 1V_{RMS}$, $R_S = R_L = 50\Omega$, Figure 4 (Note 8)			-70		dB
Total Harmonic Distortion Plus Noise	THD+N	ANO_ to COM_, $f = 20Hz$ to 20kHz, $V_{COM_} = 0.5V_{P-P}$, DC bias = 0V, $R_L = 600\Omega$			0.05		%
LOGIC INPUT							
Input Logic-High	V_{IH}			1.6			V
Input Logic-Low	V_{IL}					0.4	V
Input Leakage Current	I_{IN}	MAX14508E/MAX14509E/MAX14509AE, $V_{CB} = 0V$ or V_{CC}		-1		+1	μA
VBUS Detection Threshold	V_{VBDET}			$V_{CC} +$ 0.2		$V_{CC} +$ 1V	v

Electrical Characteristics (continued)

($V_{CC} = +2.7V$ to $+5.0V$, $T_A = -40^{\circ}C$ to $+85^{\circ}C$, unless otherwise noted. Typical values are at $V_{CC} = +3.0V$, $T_A = +25^{\circ}C$.) (Note 3)

PARAMETER	SYMBOL	CONDITIONS	MIN	TYP	MAX	UNITS
ESD PROTECTION						
All Pins		Human Body Model		±2		kV
COM1, COM2		Human Body Model		±15		kV

Note 3: All devices are 100% production tested at $T_A = +25^{\circ}C$. All temperature limits are guaranteed by design.

Note 4: The switch turns off for voltages above V_{FP} , protecting downstream circuits in case of a fault condition.

Note 5: Guaranteed by design.

Note 6: $\Delta R_{ON(MAX)} = ABS(R_{ON(CH1)} - R_{ON(CH2)})$

Note 7: Flatness is defined as the difference between the maximum and minimum value of on-resistance, as measured over specified analog signal ranges.

Note 8: Between two switches.

Test Circuits/Timing Diagrams

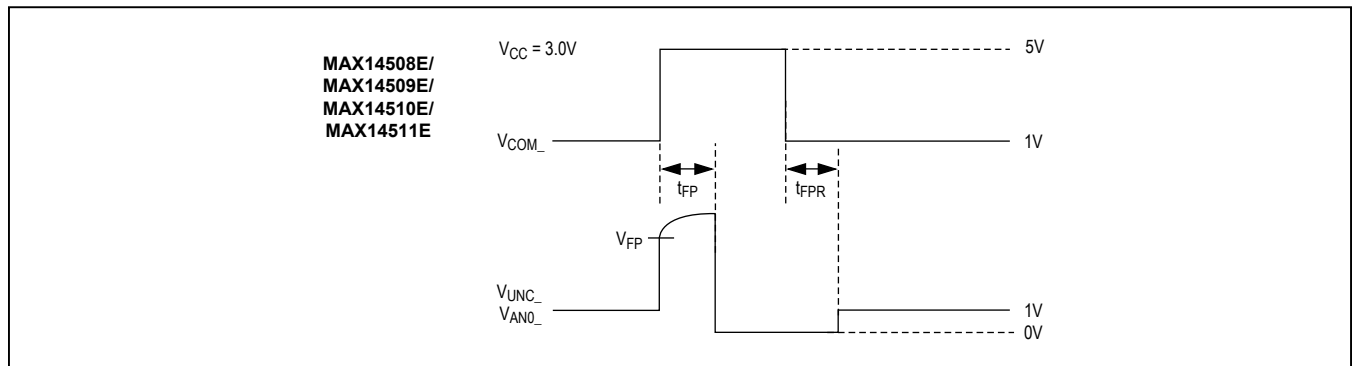

Figure 1. Fault Protection

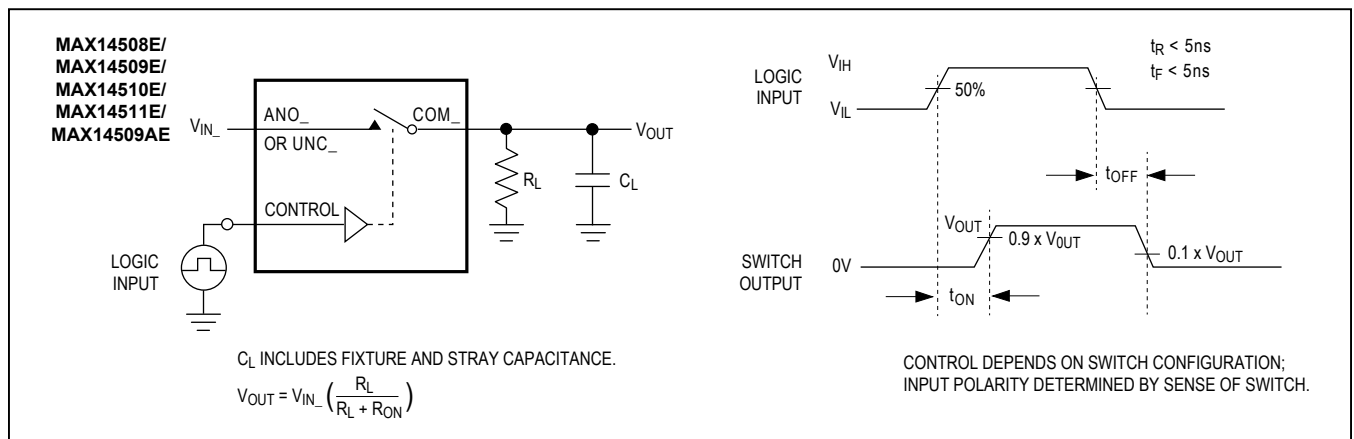

Figure 2. Switching Time

Test Circuits/Timing Diagrams (continued)

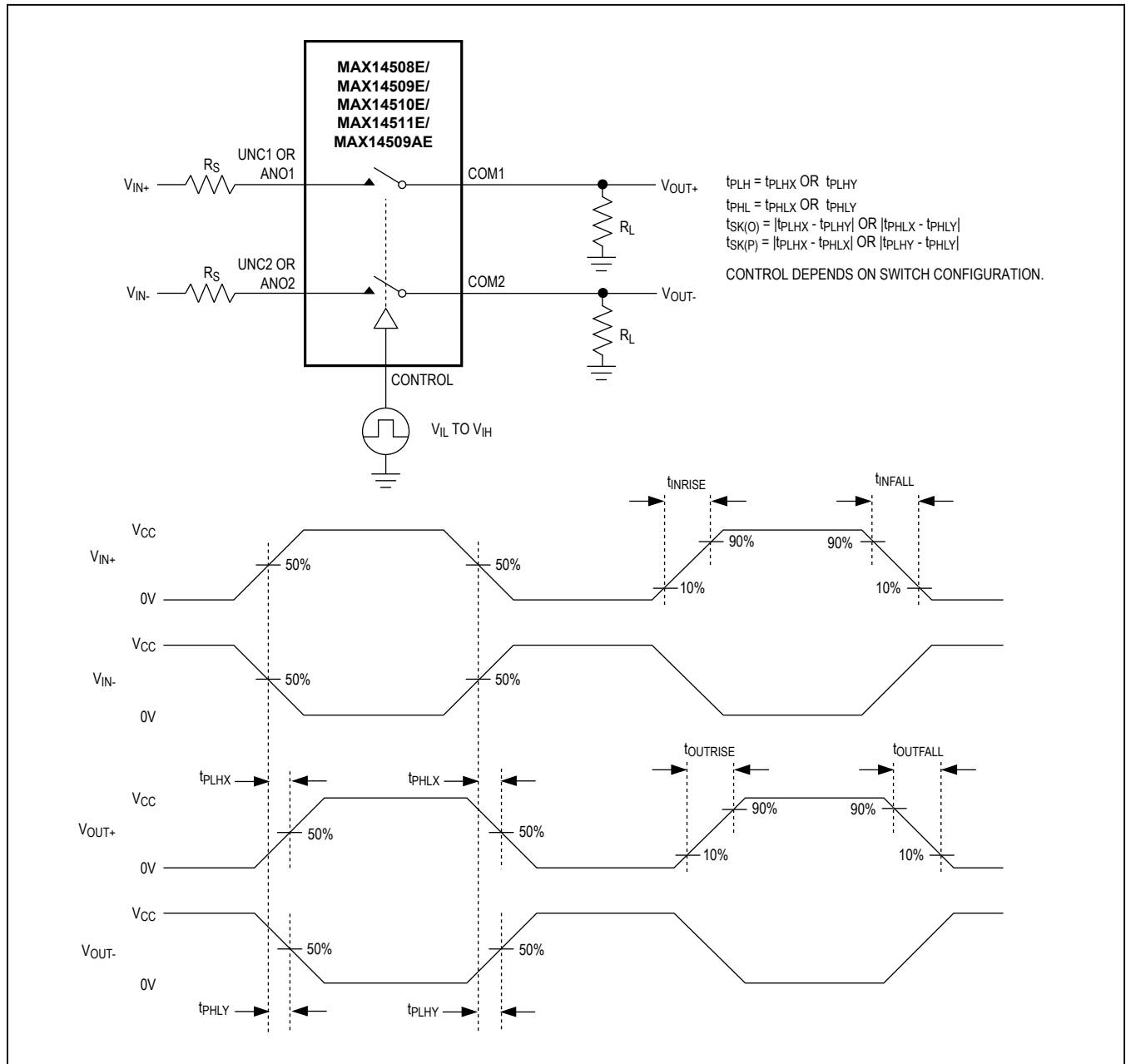

Figure 3. Output Skew

Test Circuits/Timing Diagrams (continued)

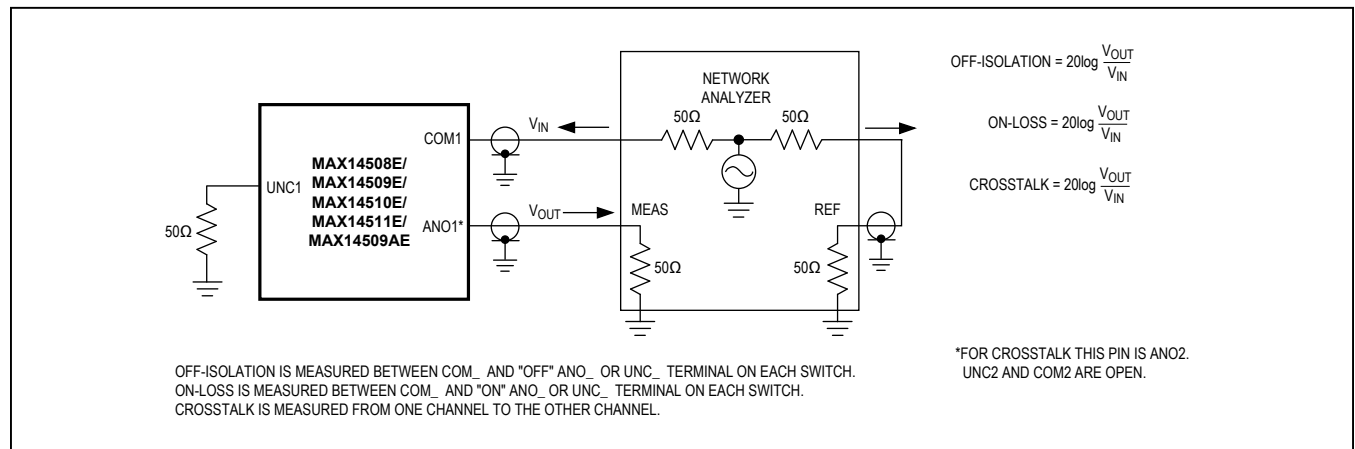
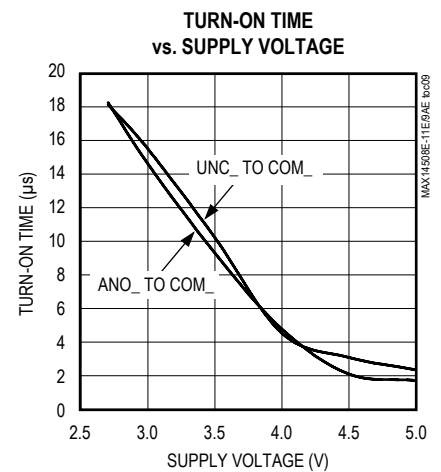
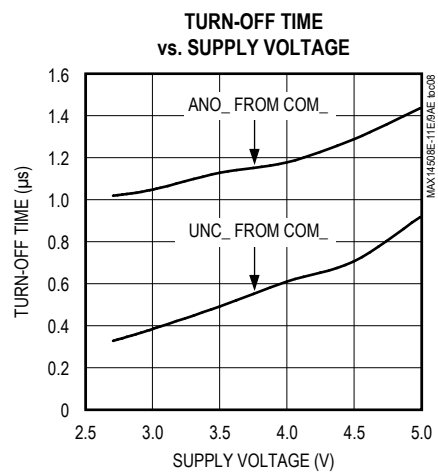
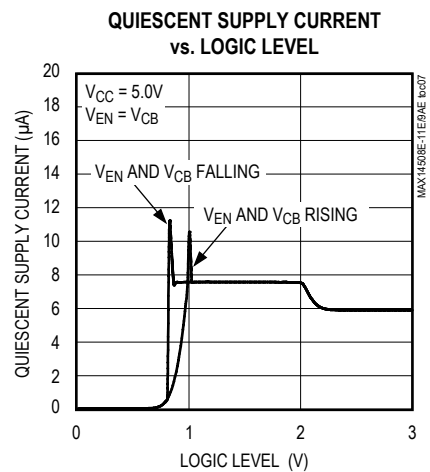
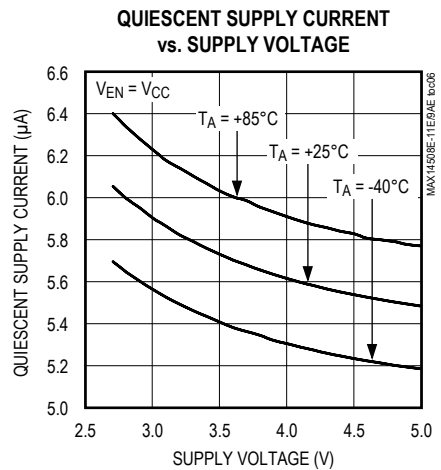
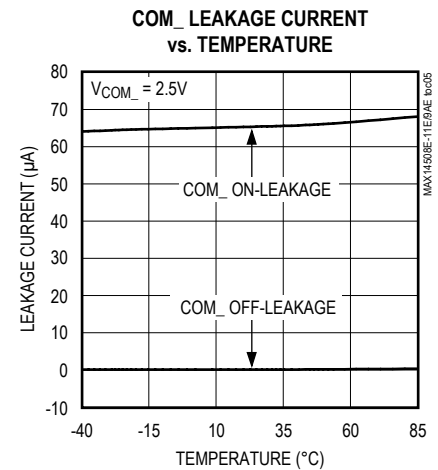
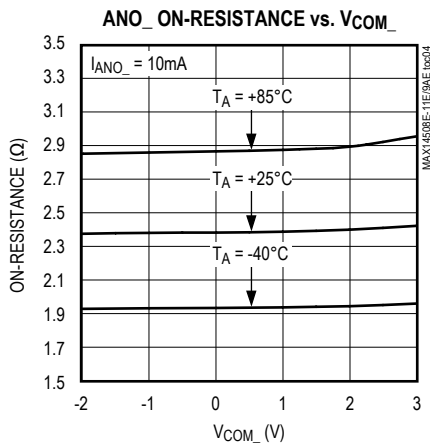
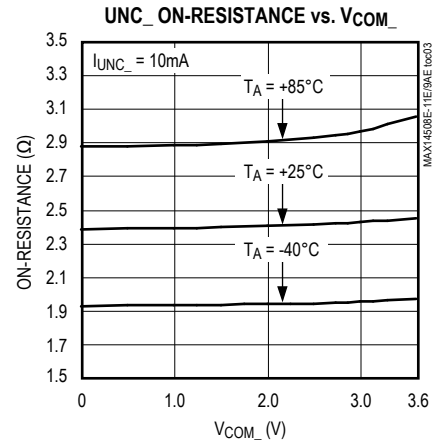
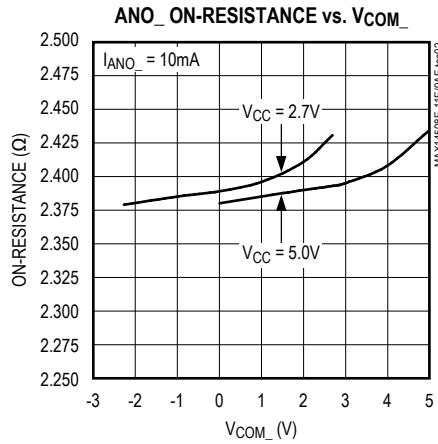
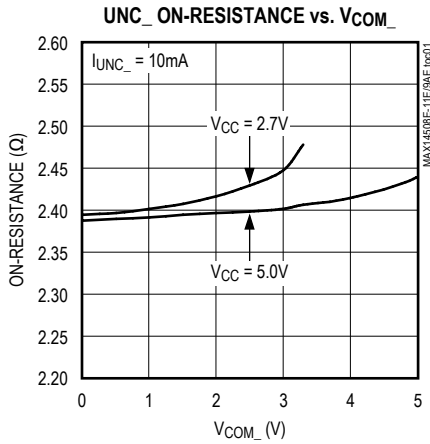

Figure 4. On-Loss, Off-Isolation, and Crosstalk

Typical Operating Characteristics

($V_{CC} = 3.0V$, $T_A = +25^\circ C$, unless otherwise noted.)



Typical Operating Characteristics (continued)

(V_{CC} = 3.0V, T_A = +25°C, unless otherwise noted.)

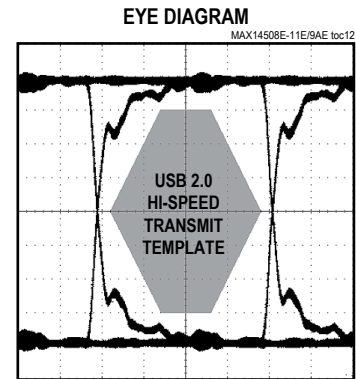
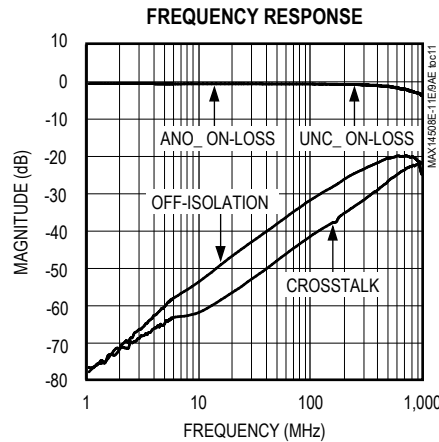
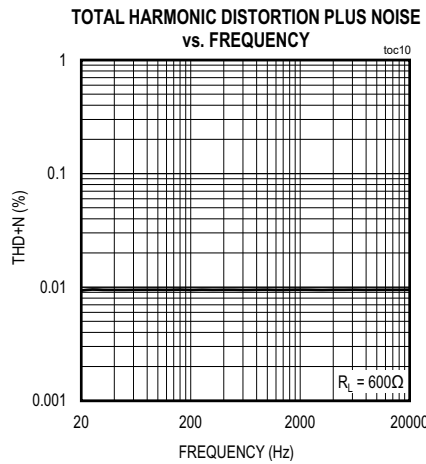

Pin Description

PIN		NAME	FUNCTION
MAX14508E/ MAX14509E/ MAX14509AEE	MAX14510E/ MAX14511E		
1	1	UNC1	USB Input 1. Normally closed terminal for switch 1.
2	2	ANO2	Audio Input 2. Normally open terminal for switch 2.
3	3	ANO1	Audio Input 1. Normally open terminal for switch 1.
4	4	GND	Ground
5	5	V _{CC}	Positive Supply-Voltage Input. Bypass V _{CC} to GND with a 0.1μF capacitor as close to the device as possible.
6	6	COM1	Common Terminal for Switch 1
7	7	COM2	Common Terminal for Switch 2
8	—	CB	Digital Control Input. Drive CB low to connect COM_ to UNC_. Drive CB high to connect COM_ to ANO_.
9	—	EN	Active-High Enable Input. Drive EN high for normal operation. Drive EN low to put switches in high impedance. Do not connect negative signals to ANO_ or COM_ when EN is low.
10	10	UNC2	USB Input 2. Normally closed terminal for switch 2.
—	8	AOR	Audio Override Input. Drive AOR low to have VB control the switch. Drive AOR high to connect COM_ to ANO_. AOR has an internal pulldown resistor to GND.
—	9	VB	VBUS Detection Input. If V _{VB} ≥ V _{VBDET} , COM_ connects to UNC_. Otherwise, COM_ connects to ANO_.

MAX14508E/MAX14509E/MAX14509AE Functional Diagrams/Truth Table

MAX14508E/MAX14509E/MAX14509AE					MAX14508E
EN	CB	UNC_	ANO_	COM_	ANO_SHUNT
1	0	On	Off	–	On
1	1	Off	On	–	Off
0	0	Off	Off	Hi-Z	On
0	1	Off	Off	Hi-Z	Off

MAX14510E/MAX14511E Functional Diagrams/Truth Table

MAX14510E/MAX14511E				MAX14510E
VB	AOR	UNC_	ANO_	ANO_SHUNT
$> V_{VBDET}$	0	On	Off	On
$< V_{VBDET}$	0	Off	On	Off
X	1	Off	On	Off

X = Don't Care

MAX14508E–MAX14511E/ MAX14509AE

Detailed Description

The MAX14508E–MAX14511E/MAX14509AE are high-ESD-protected single DPDT switches that operate from a +2.7V to +5.0V supply and are designed to multiplex USB 2.0 Hi-Speed signals and AC-coupled analog signals. These switches combine the low on-capacitance (C_{ON}) and low on-resistance (R_{ON}) necessary for high-performance switching applications. These devices meet the requirements for USB low-speed and full-speed signaling. The negative signal capability of the analog channel allows signals below ground to pass through without distortion.

Analog Signal Levels

The MAX14508E–MAX14511E/MAX14509AE are bidirectional, allowing ANO_, UNC_, and COM_ to be configured as either inputs or outputs. Note that UNC_ and ANO_ are only protected against ESD up to $\pm 2\text{kV}$ (Human Body Model) and may require additional ESD protection if used as outputs. These devices feature a charge pump that generates a negative supply to allow analog signals as low as $V_{CC} - 5.0\text{V}$ to pass through ANO_. This allows AC-coupled signals that drop below ground to pass when operating from a single power supply. The negative charge pump is controlled by the enable line and the output of the COM_ fault protection circuit. The negative charge pump is active when EN is high and $V_{COM} < V_{FP}$. Note that if the fault protection is activated by a COM_ voltage greater than V_{FP} , there must not be a negative voltage attached to the ANO_ inputs. For the MAX14508E/MAX14509E/MAX14509AE connect negative signals to ANO_ or COM_ only when EN is driven high.

Overvoltage Fault Protection

The MAX14508E–MAX14511E feature overvoltage fault protection on COM_, allowing compliance with USB requirements for voltage levels. Fault protection is triggered if the voltage applied to COM_ rises above V_{FP} , protecting the switch and USB transceiver from damaging voltage levels.

VBUS Detection Input

The MAX14510E/MAX14511E feature a VBUS detection input (VB) that connects COM_ to UNC_ when V_{VB} exceeds the VBUS detection threshold (V_{VBDET}). For applications where VBUS is always present, drive the Audio Override Input (AOR) high to connect ANO_ to COM_ (see the [MAX14510E/MAX14511E Functional Diagrams/Truth Table](#)). Drive AOR low to have VB control the switch position. Drive AOR rail-to-rail to minimize power consumption.

USB 2.0 Hi-Speed and Audio Switches with Negative Signal Capability

Digital Control Input (CB)

The MAX14508E/MAX14509E/MAX14509AE provide a single-bit control logic input, CB. CB controls the switch position as shown in the [MAX14508E/MAX14509E/MAX14509AE Functional Diagrams/Truth Table](#). Drive CB rail-to-rail to minimize power consumption.

Enable Input (EN)

The MAX14508E/MAX14509E/MAX14509AE feature a shutdown mode that reduces the supply current to less than 10nA and places the switches in high impedance. Drive EN low to place the devices in shutdown mode. Drive EN high for normal operation.

Click-and-Pop Suppression

The switched 100 Ω shunt resistors on the MAX14508E/MAX14510E automatically discharge any capacitance at the ANO_ terminals when they are unconnected from COM_. This reduces audio click-and-pop sounds that may occur when switching between USB and audio sources.

Applications Information

Extended ESD Protection

ESD-protection structures are incorporated on all pins to protect against electrostatic discharges up to $\pm 2\text{kV}$ (Human Body Model) encountered during handling and assembly. COM1 and COM2 are further protected against ESD up to $\pm 15\text{kV}$ (Human Body Model) without damage. **The ESD structures withstand high ESD both in normal operation and when the device is powered down.** After an ESD event, the MAX14508E–MAX14511E/MAX14509AE continue to function without latchup.

ESD Test Conditions

ESD performance depends on a variety of conditions. Contact Maxim for a reliability report that documents test setup, test methodology, and test results.

Human Body Model

[Figure 5](#) shows the Human Body Model. [Figure 6](#) shows the current waveform it generates when discharged into a low impedance. This model consists of a 100pF capacitor charged to the ESD voltage of interest that is then discharged into the device through a 1.5k Ω resistor.

Layout

USB Hi-Speed requires careful PCB layout with 45 Ω single-ended/90 Ω differential controlled-impedance matched traces of equal lengths. Ensure that bypass capacitors are as close to the device as possible. Use large ground planes where possible.

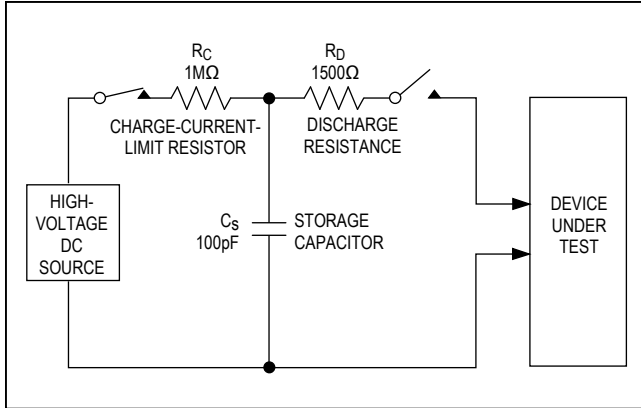

Figure 5. Human Body ESD Test Model

Power-Supply Sequencing

Caution: Do not exceed the absolute maximum ratings because stresses beyond the listed ratings may cause permanent damage to the device.

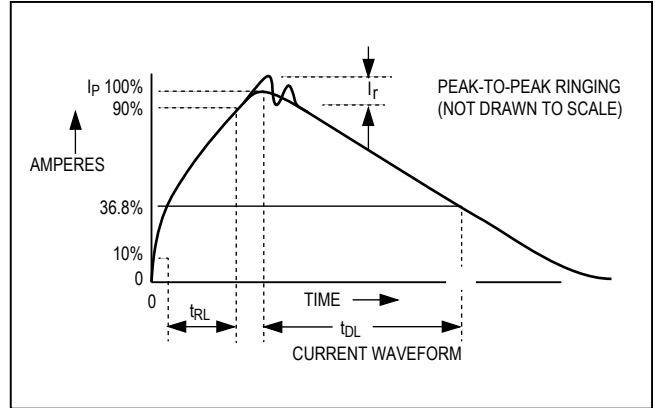
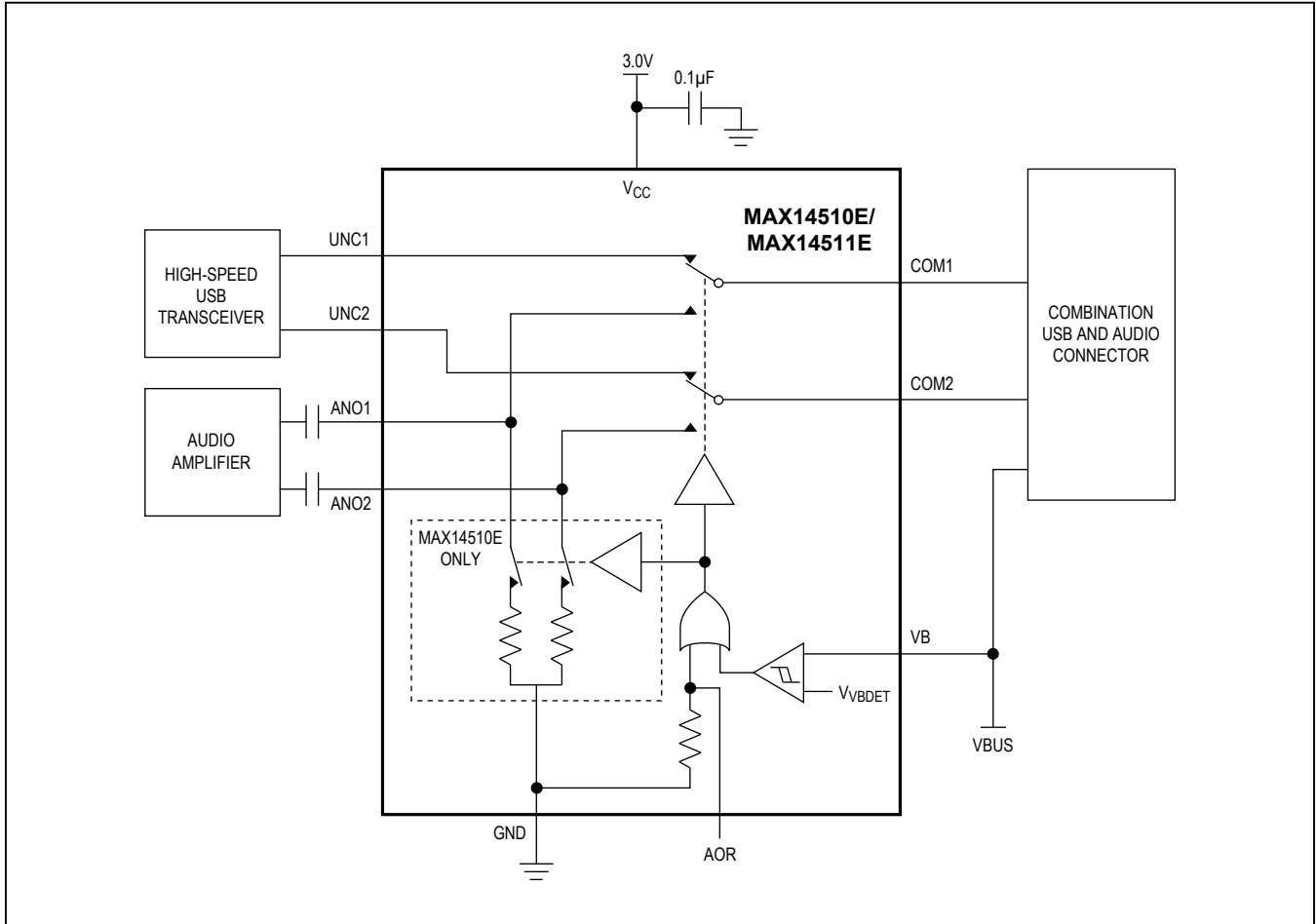

Figure 6. Human Body Current Waveform

Proper power-supply sequencing is recommended for all devices. Apply V_{CC} before applying analog signals, especially if the analog signal is not current limited.

Typical Operating Circuit



Chip Information

PROCESS: BiCMOS

Package Information

For the latest package outline information and land patterns (footprints), go to www.maximintegrated.com/packages. Note that a "+", "#", or "-" in the package code indicates RoHS status only. Package drawings may show a different suffix character, but the drawing pertains to the package regardless of RoHS status.

PACKAGE TYPE	PACKAGE CODE	OUTLINE NO.
10 Ultra-Thin QFN	V101A1CN+1	21-0028

Revision History

REVISION NUMBER	REVISION DATE	DESCRIPTION	PAGES CHANGED
0	5/08	Initial release	—
1	3/09	Released the MAX14510E, updated <i>Absolute Maximum Ratings</i> , <i>Electrical Characteristics</i> , Figure 4, and <i>Layout</i> section.	1, 2, 3, 5, 8, 12
2	5/17	Updated Total Harmonic Distortion Plus Noise typical value in <i>Electrical Characteristics</i> table and updated TOC10 in <i>Typical Operating Characteristics</i> section, corrected THD+N, TOC10, and packaging code	4, 10, 14
3	11/17	Updated <i>Electrical Characteristics</i> table	2, 4

For pricing, delivery, and ordering information, please contact Maxim Direct at 1-888-629-4642, or visit Maxim Integrated's website at www.maximintegrated.com.

Maxim Integrated cannot assume responsibility for use of any circuitry other than circuitry entirely embodied in a Maxim Integrated product. No circuit patent licenses are implied. Maxim Integrated reserves the right to change the circuitry and specifications without notice at any time. The parametric values (min and max limits) shown in the *Electrical Characteristics* table are guaranteed. Other parametric values quoted in this data sheet are provided for guidance.