



# M95512-DR M95512-R M95512-W

512 Kbit serial SPI bus EEPROM  
with high-speed clock

## Features

- Compatible with the Serial Peripheral Interface (SPI) bus
- Memory array
  - 512 Kb (64 Kbytes) of EEPROM
  - Page size: 128 bytes
- Additional Write lockable Page (Identification page)
- Write
  - Byte Write within 5 ms
  - Page Write within 5 ms
- Write Protect: quarter, half or whole memory array
- High-speed clock frequency (20 MHz)
- Single supply voltage: 1.8 V to 5.5 V
- More than 1 Million Write cycles
- More than 40-year data retention
- Enhanced ESD Protection
- Packages
  - ECOPACK2® (RoHS compliant and Halogen-free)

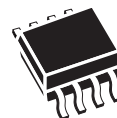

SO8 (MN)  
150 mils width



TSSOP8 (DW)  
169 mils width



UFDFPN8 (MB)  
2 × 3 mm (MLP)



WLCSP (CS)

# Contents

<b>1</b>	<b>Description</b> .....	<b>6</b>
<b>2</b>	<b>Signal description</b> .....	<b>8</b>
2.1	Serial Data output (Q) .....	8
2.2	Serial Data input (D) .....	8
2.3	Serial Clock (C) .....	8
2.4	Chip Select ( $\overline{S}$ ) .....	8
2.5	Hold ( $\overline{HOLD}$ ) .....	8
2.6	Write Protect ( $\overline{W}$ ) .....	9
2.7	V <sub>CC</sub> supply voltage .....	9
2.8	V <sub>SS</sub> ground .....	9
<b>3</b>	<b>Connecting to the SPI bus</b> .....	<b>10</b>
3.1	SPI modes .....	11
<b>4</b>	<b>Operating features</b> .....	<b>12</b>
4.1	Supply voltage (V <sub>CC</sub> ) .....	12
4.1.1	Operating supply voltage V <sub>CC</sub> .....	12
4.1.2	Device reset .....	12
4.1.3	Power-up conditions .....	12
4.1.4	Power-down .....	13
4.2	Active Power and Standby Power modes .....	13
4.3	Hold condition .....	13
4.4	Status register .....	14
4.5	Data protection and protocol control .....	14
<b>5</b>	<b>Memory organization</b> .....	<b>15</b>
<b>6</b>	<b>Instructions</b> .....	<b>16</b>
6.1	Write Enable (WREN) .....	17
6.2	Write Disable (WRDI) .....	17
6.3	Read Status Register (RDSR) .....	18
6.3.1	WIP bit .....	18

---

6.3.2	WEL bit	18
6.3.3	BP1, BP0 bits	18
6.3.4	SRWD bit	18
6.4	Write Status Register (WRSR)	20
6.5	Read from Memory Array (READ)	22
6.6	Write to Memory Array (WRITE)	23
6.7	Read Identification Page (available only in M95512-DR devices)	25
6.8	Write Identification Page (available only in M95512-DR devices)	26
6.9	Read Lock Status (available only in M95512-DR devices)	27
6.10	Lock ID (available only in M95512-DR devices)	27
<b>7</b>	<b>ECC (error correction code) and write cycling</b>	<b>29</b>
<b>8</b>	<b>Power-up and delivery state</b>	<b>29</b>
8.1	Power-up state	29
8.2	Initial delivery state	29
<b>9</b>	<b>Maximum rating</b>	<b>30</b>
<b>10</b>	<b>DC and AC parameters</b>	<b>31</b>
<b>11</b>	<b>Package mechanical data</b>	<b>39</b>
<b>12</b>	<b>Part numbering</b>	<b>43</b>
<b>13</b>	<b>Revision history</b>	<b>45</b>

## List of tables

Table 1.	Signal names	7
Table 2.	Write-protected block size	14
Table 3.	M95512-W and M95512-R instruction set	16
Table 4.	M95512-DR instruction set	16
Table 5.	Status register format	18
Table 6.	Protection modes	21
Table 7.	Absolute maximum ratings	30
Table 8.	Operating conditions (M95512-W device grade 6)	31
Table 9.	Operating conditions (M95512-W device grade 3)	31
Table 10.	Operating conditions (M95512-R and M95512-DR)	31
Table 11.	AC measurement conditions	31
Table 12.	Capacitance	32
Table 13.	DC characteristics (current M95512-W products)	32
Table 14.	DC characteristics (new M95512-W products)	33
Table 15.	DC characteristics (current and new M95512-R and M95512-DR products)	33
Table 16.	AC characteristics (current M95512-W products)	34
Table 17.	AC characteristics (New M95512-W products)	35
Table 18.	AC characteristics (current and new M95512-R and M95512-DR products)	36
Table 19.	SO8N – 8 lead plastic small outline, 150 mils body width, package mechanical data	39
Table 20.	TSSOP8 – 8 lead thin shrink small outline, package mechanical data	40
Table 21.	UFDFPN8 (MLP8) – 8-lead ultra thin fine pitch dual flat package no lead 2 × 3 .mm, package mechanical data	41
Table 22.	WLCSP-R – 8-bump wafer-length chip-scale package mechanical data	42
Table 23.	Ordering information scheme	43
Table 24.	Available M95512 products (package, voltage range, temperature grade)	44
Table 25.	Available M95512-DR products (package, voltage range, temperature grade)	44
Table 26.	Document revision history	45

## List of figures

Figure 1.	Logic diagram . . . . .	6
Figure 2.	SO8, TSSOP8 and UFDFPN8 connections . . . . .	7
Figure 3.	WLCSP connections (top view, marking side, with balls on the underside) . . . . .	7
Figure 4.	Bus master and memory devices on the SPI bus . . . . .	10
Figure 5.	SPI modes supported . . . . .	11
Figure 6.	Hold condition activation. . . . .	13
Figure 7.	Block diagram . . . . .	15
Figure 8.	Write Enable (WREN) sequence . . . . .	17
Figure 9.	Write Disable (WRDI) sequence . . . . .	17
Figure 10.	Read Status Register (RDSR) sequence . . . . .	19
Figure 11.	Write Status Register (WRSR) sequence . . . . .	20
Figure 12.	Read from Memory Array (READ) sequence . . . . .	22
Figure 13.	Byte Write (WRITE) sequence . . . . .	23
Figure 14.	Page Write (WRITE) sequence . . . . .	24
Figure 15.	Read Identification Page sequence . . . . .	25
Figure 16.	Write Identification Page sequence . . . . .	26
Figure 17.	Read Lock Status sequence . . . . .	27
Figure 18.	Lock ID sequence . . . . .	28
Figure 19.	AC measurement I/O waveform . . . . .	31
Figure 20.	Serial input timing . . . . .	37
Figure 21.	Hold timing . . . . .	37
Figure 22.	Serial output timing . . . . .	38
Figure 23.	SO8N – 8 lead plastic small outline, 150 mils body width, package outline . . . . .	39
Figure 24.	TSSOP8 – 8 lead thin shrink small outline, package outline . . . . .	40
Figure 25.	UFDFPN8 (MLP8) – 8-lead ultra thin fine pitch dual flat package no lead 2 × 3 mm, package outline . . . . .	41
Figure 26.	WLCSP-R – 8-bump wafer-length chip-scale package outline . . . . .	42

# 1 Description

The M95512-W, M95512-R and M95512-DR are electrically erasable programmable memory (EEPROM) devices accessed by a high-speed SPI-compatible bus. In the rest of the document these devices are referred to as M95512, unless otherwise specified.

The M95512-DR also offers an additional page, named the Identification Page (128 bytes) which can be written and (later) permanently locked in Read-only mode. This Identification Page offers flexibility in the application board production line, as it can be used to store unique identification parameters and/or parameters specific to the production line.

**Figure 1. Logic diagram**

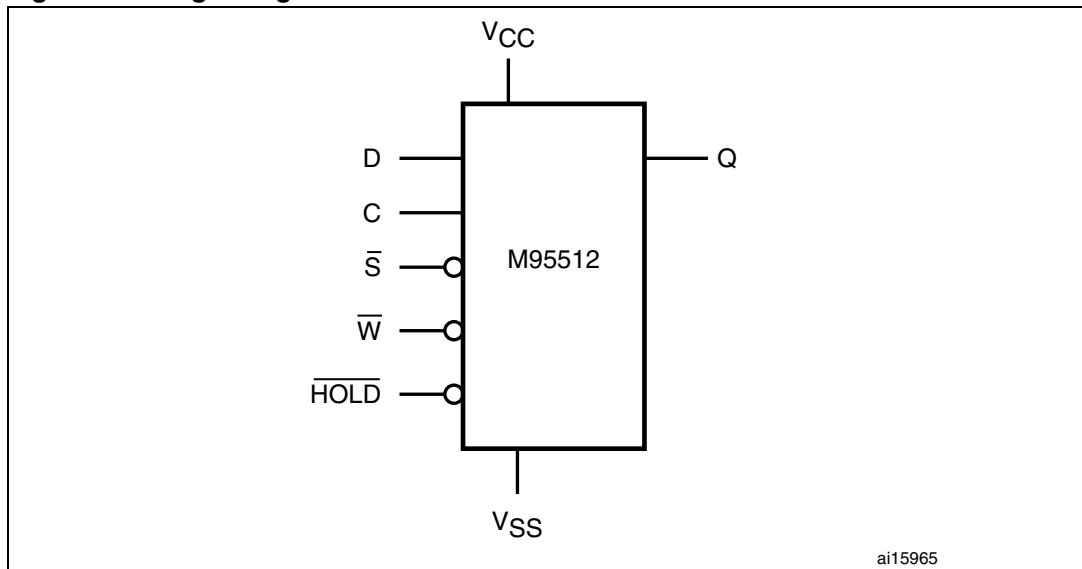

The memory array is organized as 65536 × 8 bit. The device is accessed by a simple serial interface that is SPI-compatible. The bus signals are C, D and Q, as shown in [Table 1](#) and [Figure 1](#).

The device is selected when Chip Select ( $\bar{S}$ ) is taken low. Communications with the device can be interrupted using Hold ( $\overline{\text{HOLD}}$ ).

**Table 1. Signal names**

Signal name	Function	Direction
C	Serial Clock	Input
D	Serial Data Input	Input
Q	Serial Data Output	Output
S	Chip Select	Input
$\overline{W}$	Write Protect	Input
$\overline{HOLD}$	Hold	Input
V <sub>CC</sub>	Supply voltage	
V <sub>SS</sub>	Ground	

**Caution:** As EEPROM cells loose their charge (and so their binary value) when exposed to ultra violet (UV) light, EEPROM dice delivered in wafer form or in WLCSP package by STMicroelectronics must never be exposed to UV light.

**Figure 2. SO8, TSSOP8 and UFDFPN8 connections**

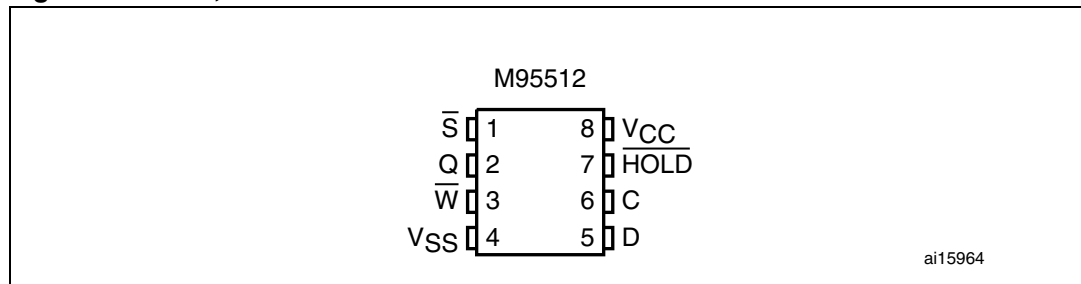

1. See [Section 11: Package mechanical data](#) for package dimensions, not and how to identify pin-1.

**Figure 3. WLCSP connections (top view, marking side, with balls on the underside)**

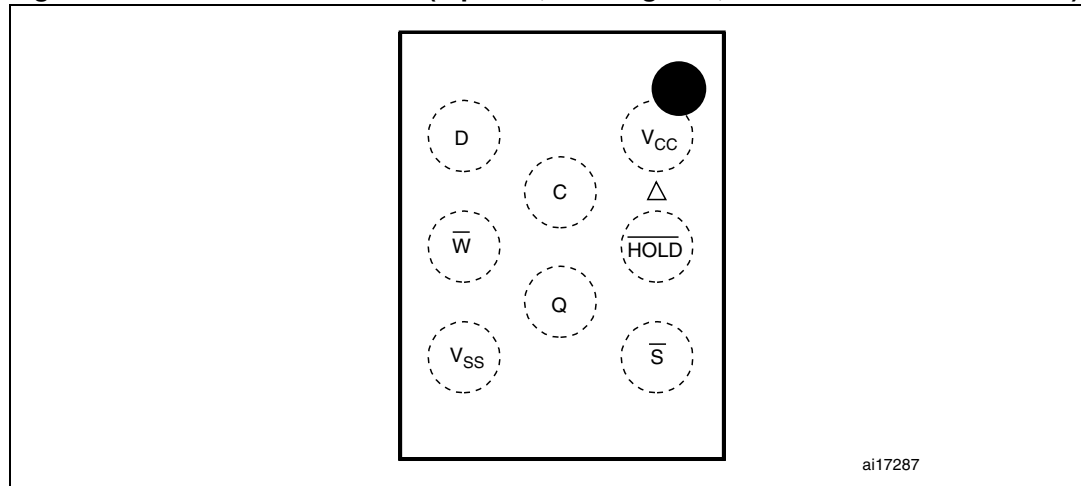

## 2 Signal description

During all operations,  $V_{CC}$  must be held stable and within the specified valid range:  $V_{CC}(\min)$  to  $V_{CC}(\max)$ .

All of the input and output signals must be held high or low (according to voltages of  $V_{IH}$ ,  $V_{OH}$ ,  $V_{IL}$  or  $V_{OL}$ , as specified in [Table 13](#) and [Table 15](#)). These signals are described next.

### 2.1 Serial Data output (Q)

This output signal is used to transfer data serially out of the device. Data is shifted out on the falling edge of Serial Clock (C).

### 2.2 Serial Data input (D)

This input signal is used to transfer data serially into the device. It receives instructions, addresses, and the data to be written. Values are latched on the rising edge of Serial Clock (C).

### 2.3 Serial Clock (C)

This input signal provides the timing of the serial interface. Instructions, addresses, or data present at Serial Data Input (D) are latched on the rising edge of Serial Clock (C). Data on Serial Data Output (Q) changes after the falling edge of Serial Clock (C).

### 2.4 Chip Select ( $\overline{S}$ )

When this input signal is high, the device is deselected and Serial Data Output (Q) is at high impedance. Unless an internal Write cycle is in progress, the device will be in the Standby Power mode. Driving Chip Select ( $\overline{S}$ ) low selects the device, placing it in the Active Power mode.

After Power-up, a falling edge on Chip Select ( $\overline{S}$ ) is required prior to the start of any instruction.

### 2.5 Hold ( $\overline{HOLD}$ )

The Hold ( $\overline{HOLD}$ ) signal is used to pause any serial communications with the device without deselecting the device.

During the Hold condition, the Serial Data Output (Q) is high impedance, and Serial Data Input (D) and Serial Clock (C) are Don't Care.

To start the Hold condition, the device must be selected, with Chip Select ( $\overline{S}$ ) driven low.



## 2.6 Write Protect ( $\overline{W}$ )

The main purpose of this input signal is to freeze the size of the area of memory that is protected against Write instructions (as specified by the values in the BP1 and BP0 bits of the Status Register).

This pin must be driven either high or low, and must be stable during all write instructions.

## 2.7 $V_{CC}$ supply voltage

$V_{CC}$  is the supply voltage.

## 2.8 $V_{SS}$ ground

$V_{SS}$  is the reference for the  $V_{CC}$  supply voltage.

### 3 Connecting to the SPI bus

These devices are fully compatible with the SPI protocol.

All instructions, addresses and input data bytes are shifted in to the device, most significant bit first. The Serial Data Input (D) is sampled on the first rising edge of the Serial Clock (C) after Chip Select ( $\bar{S}$ ) goes low.

All output data bytes are shifted out of the device, most significant bit first. The Serial Data Output (Q) is latched on the first falling edge of the Serial Clock (C) after the instruction (such as the Read from Memory Array and Read Status Register instructions) have been clocked into the device.

**Figure 4. Bus master and memory devices on the SPI bus**

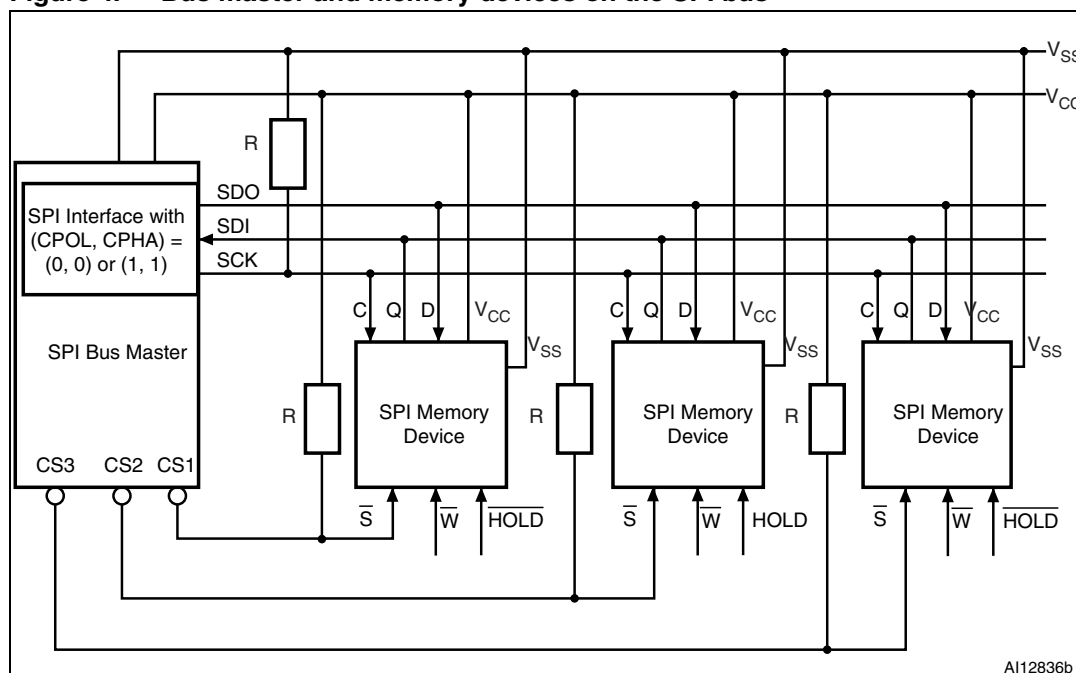

1. The Write Protect ( $\bar{W}$ ) and Hold ( $\overline{HOLD}$ ) signals should be driven, high or low as appropriate.

Figure 4 shows an example of three memory devices connected to an MCU, on an SPI bus. Only one device is selected at a time, so only one device drives the Serial Data Output (Q) line at a time, the other devices are high impedance.

The pull-up resistor R (represented in Figure 4) ensures that no device is selected if the Bus Master leaves the  $\bar{S}$  line in the high impedance state.

In applications where the Bus Master might enter a state where all inputs/outputs SPI lines are in high impedance at the same time (for example, if the Bus Master is reset during the transmission of an instruction), the clock line (C) must be connected to an external pull-down resistor so that, if all inputs/outputs become high impedance, the C line is pulled low (while the  $\bar{S}$  line is pulled high). This ensures that  $\bar{S}$  and C do not become high at the same time, and so, that the  $t_{SHCH}$  requirement is met.

The typical value of R is 100 k $\Omega$ .

### 3.1 SPI modes

These devices can be driven by a microcontroller with its SPI peripheral running in either of the two following modes:

- CPOL=0, CPHA=0
- CPOL=1, CPHA=1

For these two modes, input data is latched in on the rising edge of Serial Clock (C), and output data is available from the falling edge of Serial Clock (C).

The difference between the two modes, as shown in [Figure 5](#), is the clock polarity when the bus master is in Stand-by mode and not transferring data:

- C remains at 0 for (CPOL=0, CPHA=0)
- C remains at 1 for (CPOL=1, CPHA=1)

**Figure 5. SPI modes supported**

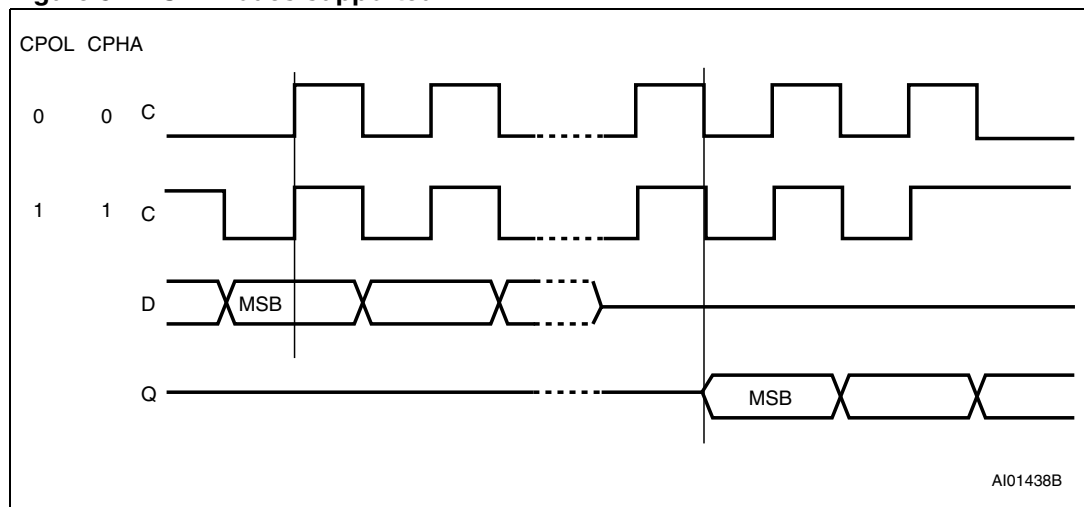

## 4 Operating features

### 4.1 Supply voltage ( $V_{CC}$ )

#### 4.1.1 Operating supply voltage $V_{CC}$

Prior to selecting the memory and issuing instructions to it, a valid and stable  $V_{CC}$  voltage within the specified [ $V_{CC}(\min)$ ,  $V_{CC}(\max)$ ] range must be applied (see [Table 8](#) and [Table 10](#)). This voltage must remain stable and valid until the end of the transmission of the instruction and, for a Write instruction, until the completion of the internal write cycle ( $t_W$ ). In order to secure a stable DC supply voltage, it is recommended to decouple the  $V_{CC}$  line with a suitable capacitor (usually of the order of 10 nF to 100 nF) close to the  $V_{CC}/V_{SS}$  package pins.

#### 4.1.2 Device reset

In order to prevent inadvertent Write operations during power-up, a power-on-reset (POR) circuit is included. At power-up, the device does not respond to any instruction until  $V_{CC}$  has reached the POR threshold voltage (this threshold is lower than the minimum  $V_{CC}$  operating voltage defined in [Table 8](#) and [Table 10](#)).

When  $V_{CC}$  passes over the POR threshold, the device is reset and in the following state:

- in the Standby Power mode
- deselected (note that when the device is deselected it is necessary to apply a falling edge on Chip Select ( $\overline{S}$ ) prior to issuing any new instruction, otherwise the instruction is not executed)
- Status register values:
  - the Write Enable Latch (WEL) bit is reset to 0
  - the Write In Progress (WIP) bit is reset to 0
  - the SRWD, BP1 and BP0 bits remain unchanged (non-volatile bits).

When  $V_{CC}$  passes over the POR threshold, the device is reset and enters the Standby Power mode, however, the device must not be accessed until  $V_{CC}$  reaches a valid and stable  $V_{CC}$  voltage within the specified [ $V_{CC}(\min)$ ,  $V_{CC}(\max)$ ] range defined in [Table 8](#) and [Table 10](#).

#### 4.1.3 Power-up conditions

When the power supply is turned on,  $V_{CC}$  rises continuously from  $V_{SS}$  to  $V_{CC}$ . During this time, the Chip Select ( $\overline{S}$ ) line is not allowed to float but should follow the  $V_{CC}$  voltage. It is therefore recommended to connect the  $\overline{S}$  line to  $V_{CC}$  via a suitable pull-up resistor (see [Figure 4](#)).

In addition, the Chip Select ( $\overline{S}$ ) input offers a built-in safety feature, as the  $\overline{S}$  input is edge sensitive as well as level sensitive: after power-up, the device does not become selected until a falling edge has first been detected on Chip Select ( $\overline{S}$ ). This ensures that Chip Select ( $\overline{S}$ ) must have been high, prior to going low to start the first operation.

The  $V_{CC}$  voltage has to rise continuously from 0 V up to the minimum  $V_{CC}$  operating voltage defined in [Table 8](#) and [Table 10](#) and the rise time must not vary faster than 1 V/ $\mu$ s.

#### 4.1.4 Power-down

During power-down (continuous decrease in  $V_{CC}$  below the minimum  $V_{CC}$  operating voltage defined in [Table 8](#) and [Table 10](#)), the device must be:

- deselected (Chip Select ( $\overline{S}$ ) should be allowed to follow the voltage applied on  $V_{CC}$ )
- in Standby Power mode (that is there should not be any internal write cycle in progress).

## 4.2 Active Power and Standby Power modes

When Chip Select ( $\overline{S}$ ) is low, the device is selected, and in the Active Power mode. The device consumes  $I_{CC}$ , as specified in [Table 15](#).

When Chip Select ( $\overline{S}$ ) is high, the device is deselected. If a Write cycle is not currently in progress, the device then goes in to the Standby Power mode, and the device consumption drops to  $I_{CC1}$ .

## 4.3 Hold condition

The Hold ( $\overline{HOLD}$ ) signal is used to pause any serial communications with the device without resetting the clocking sequence.

During the Hold condition, the Serial Data Output (Q) is high impedance, and Serial Data Input (D) and Serial Clock (C) are Don't Care.

To enter the Hold condition, the device must be selected, with Chip Select ( $\overline{S}$ ) low.

Normally, the device is kept selected, for the whole duration of the Hold condition. Deselecting the device while it is in the Hold condition, has the effect of resetting the state of the device, and this mechanism can be used if it is required to reset any processes that had been in progress.

The Hold condition starts when the Hold ( $\overline{HOLD}$ ) signal is driven low at the same time as Serial Clock (C) already being low (as shown in [Figure 6](#)).

The Hold condition ends when the Hold ( $\overline{HOLD}$ ) signal is driven high at the same time as Serial Clock (C) already being low.

[Figure 6](#) also shows what happens if the rising and falling edges are not timed to coincide with Serial Clock (C) being low.

**Figure 6. Hold condition activation**

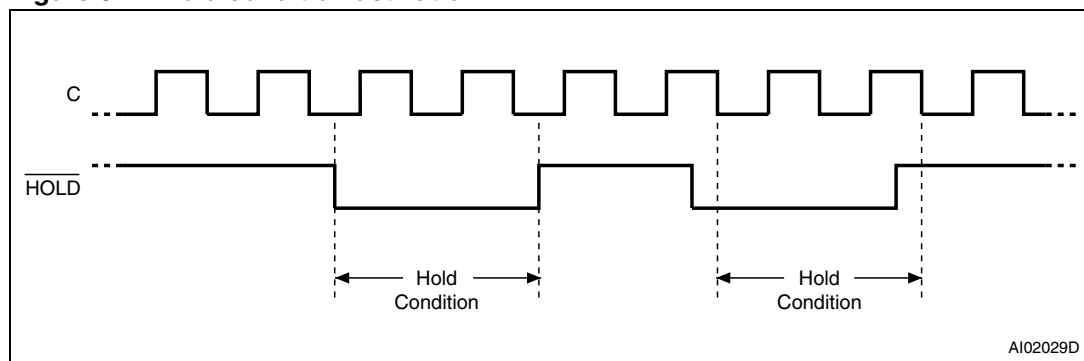

## 4.4 Status register

*Figure 7* shows the position of the Status register in the control logic of the device. The Status register contains a number of status and control bits that can be read or set (as appropriate) by specific instructions. See [Section 6.3: Read Status Register \(RDSR\)](#) for a detailed description of the Status register bits

## 4.5 Data protection and protocol control

Non-volatile memory devices can be used in environments that are particularly noisy, and within applications that could experience problems if memory bytes are corrupted. Consequently, the device features the following data protection mechanisms:

- Write and Write Status register instructions are checked that they consist of a number of clock pulses that is a multiple of eight, before they are accepted for execution.
- All instructions that modify data must be preceded by a Write Enable (WREN) instruction to set the Write Enable Latch (WEL) bit. This bit is returned to its reset state by the following events:
  - Power-up
  - Write Disable (WRDI) instruction completion
  - Write Status Register (WRSR) instruction completion
  - Write (WRITE) instruction completion
- The Block Protect (BP1, BP0) bits in the Status Register allow part of the memory to be configured as read-only.
- The Write Protect ( $\overline{W}$ ) signal is used to protect the Block Protect (BP1, BP0) bits in the Status Register.

For any instruction to be accepted, and executed, Chip Select ( $\overline{S}$ ) must be driven high after the rising edge of Serial Clock (C) for the last bit of the instruction, and before the next rising edge of Serial Clock (C).

Two points need to be noted in the previous sentence:

- The 'last bit of the instruction' can be the eighth bit of the instruction code, or the eighth bit of a data byte, depending on the instruction (except for Read Status Register (RDSR) and Read (READ) instructions).
- The 'next rising edge of Serial Clock (C)' might (or might not) be the next bus transaction for some other device on the SPI bus.

**Table 2. Write-protected block size**

Status register bits		Protected block	Protected array addresses
BP1	BP0		
0	0	none	none
0	1	Upper quarter	C000h - FFFFh
1	0	Upper half	8000h - FFFFh
1	1	Whole memory	0000h - FFFFh

# 5 Memory organization

The memory is organized as shown in *Figure 7*.

**Figure 7. Block diagram**

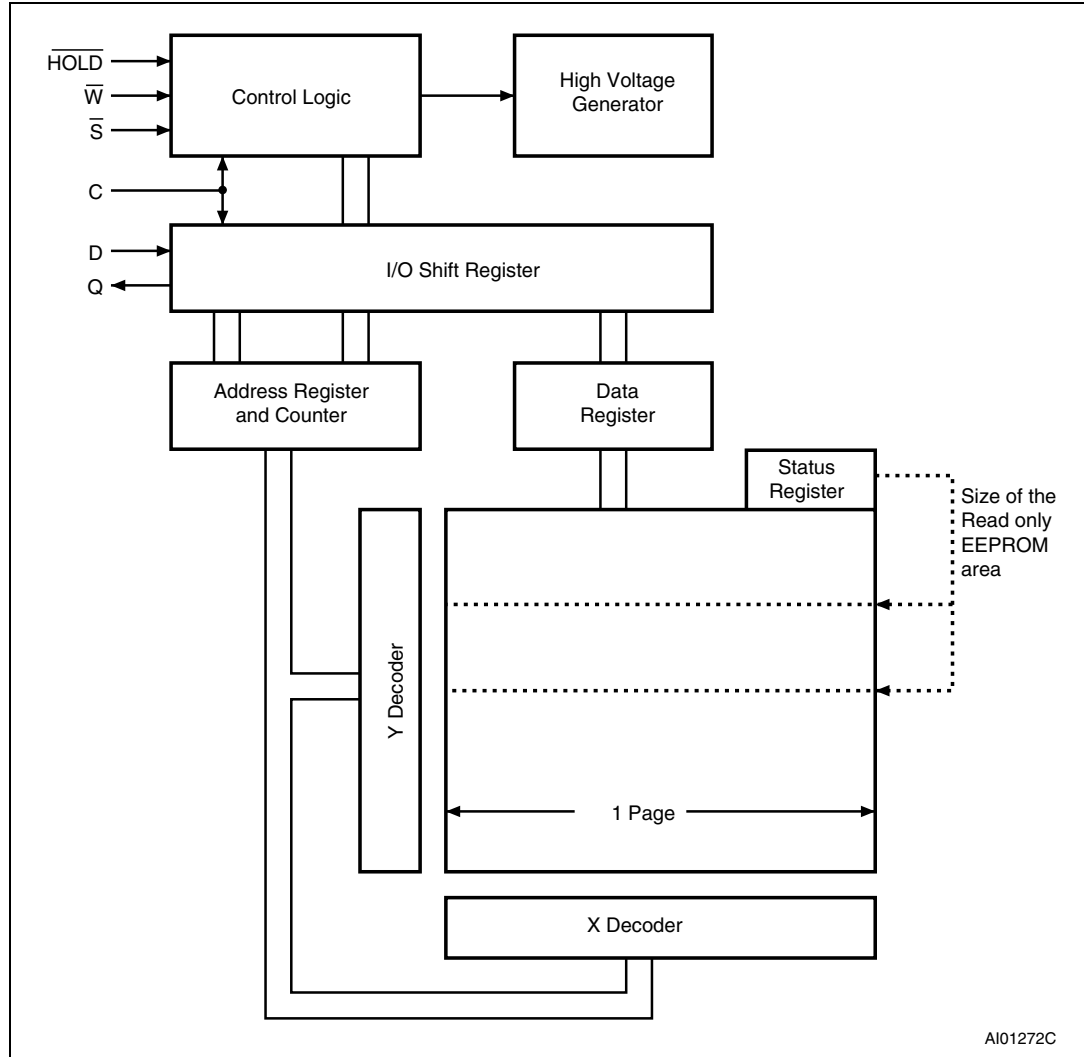

## 6 Instructions

Each instruction starts with a single-byte code, as summarized in [Table 3](#).

If an invalid instruction is sent (one not contained in [Table 3](#)), the device automatically deselects itself.

**Table 3. M95512-W and M95512-R instruction set**

Instruction	Description	Instruction format
WREN	Write Enable	0000 0110
WRDI	Write Disable	0000 0100
RDSR	Read Status Register	0000 0101
WRSR	Write Status Register	0000 0001
READ	Read from Memory Array	0000 0011
WRITE	Write to Memory Array	0000 0010

**Table 4. M95512-DR instruction set**

Instruction	Description	Instruction format
WREN	Write Enable	0000 0110
WRDI	Write Disable	0000 0100
RDSR	Read Status Register	0000 0101
WRSR	Write Status Register	0000 0001
READ	Read from Memory Array	0000 0011
WRITE	Write to Memory Array	0000 0010
Read Identification Page	Reads the page dedicated to identification.	1000 0011 <sup>(1)</sup>
Write Identification Page	Writes the page dedicated to identification.	1000 0010 <sup>(1)</sup>
Read Lock Status	Reads the lock status of the Identification Page.	1000 0011 <sup>(2)</sup>
Lock ID	Locks the Identification page in read-only mode.	1000 0010 <sup>(2)</sup>

1. Address bit A10 must be 0, all other address bits are Don't Care.

2. Address bit A10 must be 1, all other address bits are Don't Care.



## 6.1 Write Enable (WREN)

The Write Enable Latch (WEL) bit must be set prior to each WRITE and WRSR instruction. The only way to do this is to send a Write Enable instruction to the device.

As shown in [Figure 8](#), to send this instruction to the device, Chip Select ( $\bar{S}$ ) is driven low, and the bits of the instruction byte are shifted in, on Serial Data Input (D). The device then enters a wait state. It waits for a the device to be deselected, by Chip Select ( $\bar{S}$ ) being driven high.

**Figure 8. Write Enable (WREN) sequence**

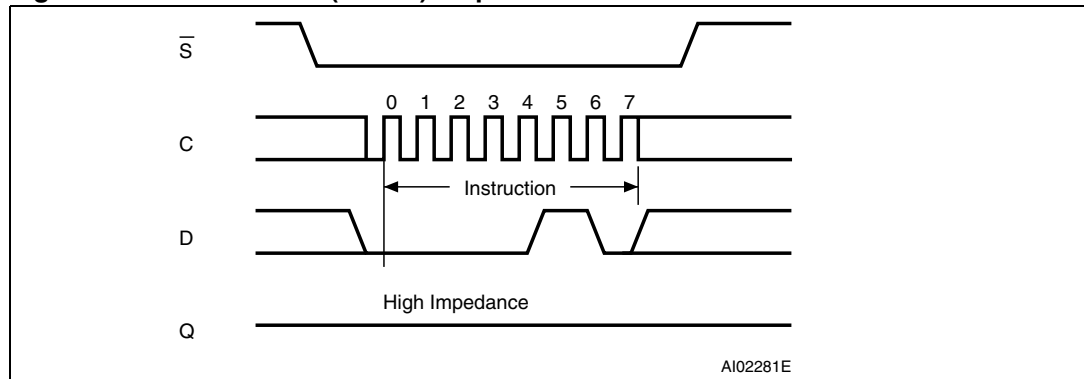

## 6.2 Write Disable (WRDI)

One way of resetting the Write Enable Latch (WEL) bit is to send a Write Disable instruction to the device.

As shown in [Figure 9](#), to send this instruction to the device, Chip Select ( $\bar{S}$ ) is driven low, and the bits of the instruction byte are shifted in, on Serial Data Input (D).

The device then enters a wait state. It waits for a the device to be deselected, by Chip Select ( $\bar{S}$ ) being driven high.

The Write Enable Latch (WEL) bit, in fact, becomes reset by any of the following events:

- Power-up
- WRDI instruction execution
- WRSR instruction completion
- WRITE instruction completion.

**Figure 9. Write Disable (WRDI) sequence**

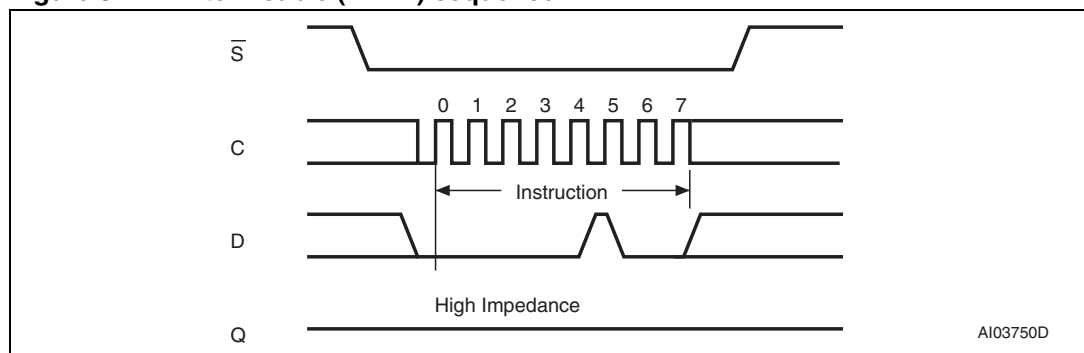

### 6.3 Read Status Register (RDSR)

The Read Status Register (RDSR) instruction allows the Status Register to be read. The Status Register may be read at any time, even while a Write or Write Status Register cycle is in progress. When one of these cycles is in progress, it is recommended to check the Write In Progress (WIP) bit before sending a new instruction to the device. It is also possible to read the Status Register continuously, as shown in [Figure 10](#).

The status and control bits of the Status Register are as follows:

#### 6.3.1 WIP bit

The Write In Progress (WIP) bit indicates whether the memory is busy with a Write or Write Status Register cycle. When set to 1, such a cycle is in progress, when reset to 0 no such cycle is in progress.

#### 6.3.2 WEL bit

The Write Enable Latch (WEL) bit indicates the status of the internal Write Enable Latch. When set to 1 the internal Write Enable Latch is set, when set to 0 the internal Write Enable Latch is reset and no Write or Write Status Register instruction is accepted.

#### 6.3.3 BP1, BP0 bits

The Block Protect (BP1, BP0) bits are non-volatile. They define the size of the area to be software protected against Write instructions. These bits are written with the Write Status Register (WRSR) instruction. When one or both of the Block Protect (BP1, BP0) bits is set to 1, the relevant memory area (as defined in [Table 5](#)) becomes protected against Write (WRITE) instructions. The Block Protect (BP1, BP0) bits can be written provided that the Hardware Protected mode has not been set.

#### 6.3.4 SRWD bit

The Status Register Write Disable (SRWD) bit is operated in conjunction with the Write Protect ( $\bar{W}$ ) signal. The Status Register Write Disable (SRWD) bit and Write Protect ( $\bar{W}$ ) signal allow the device to be put in the Hardware Protected mode (when the Status Register Write Disable (SRWD) bit is set to 1, and Write Protect ( $\bar{W}$ ) is driven low). In this mode, the non-volatile bits of the Status Register (SRWD, BP1, BP0) become read-only bits and the Write Status Register (WRSR) instruction is no longer accepted for execution.

**Table 5. Status register format**

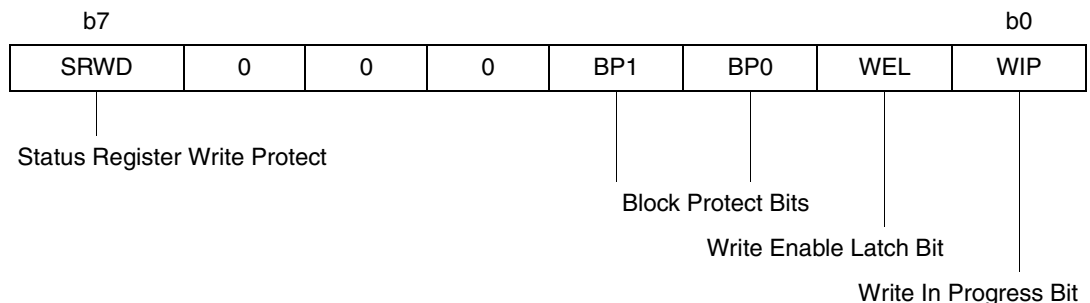
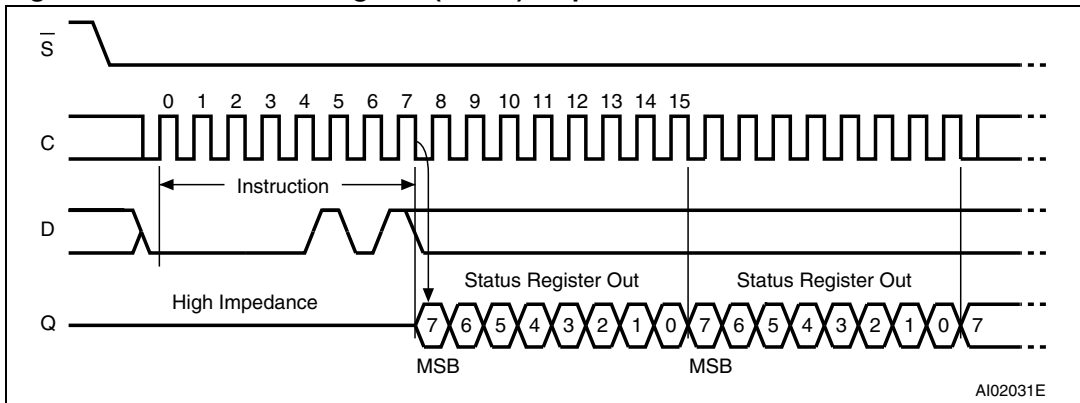

Figure 10. Read Status Register (RDSR) sequence



## 6.4 Write Status Register (WRSR)

The Write Status Register (WRSR) instruction allows new values to be written to the Status Register. Before a WRSR instruction can be accepted, a Write Enable (WREN) instruction must have been executed.

The Write Status Register (WRSR) instruction is issued by driving Chip Select ( $\bar{S}$ ) low, sending the instruction code and the data byte on Serial Data input (D) and driving Chip Select ( $\bar{S}$ ) high. Chip Select ( $\bar{S}$ ) must be driven high after the rising edge of Serial Clock (C) that latches in the eighth bit of the data byte, and before the next rising edge of Serial Clock (C). Otherwise, the Write Status Register (WRSR) instruction is not properly executed.

Driving Chip Select ( $\bar{S}$ ) high at a byte boundary of the input data triggers the self-timed Write cycle whose duration is  $t_W$  (specified in [Table 16](#) and [Table 18](#)). The instruction sequence is shown in [Figure 11](#).

While the Write Status Register cycle is in progress, the Status Register may still be read to check the value of the Write In Progress (WIP) bit: the WIP bit is 1 during the self-timed Write cycle  $t_W$ , and 0 when the Write cycle is complete. The WEL bit (Write Enable Latch) is also reset when the Write cycle  $t_W$  is complete.

The Write Status Register (WRSR) instruction allows the user to change the values of the BP1, BP0 and SRWD bits:

- The Block Protect (BP1, BP0) bits define the size of the area to be treated as read-only, as defined in [Table 6](#).
- The SRWD bit (Status Register Write Disable bit), depending on the signal applied on the Write Protect pin ( $\bar{W}$ ), allows the user to set or reset the write protection mode of the Status Register. When the Status Register is in the Write-protected mode, the Write Status Register (WRSR) instruction is *not* executed.

The contents of the SRWD and BP1, BP0 bits are updated upon completion of the WRSR instruction (after  $t_W$ ).

The Write Status Register (WRSR) instruction has no effect on Status Register bits b6, b5, b4, b1, b0. They are always read as 0.

**Figure 11. Write Status Register (WRSR) sequence**

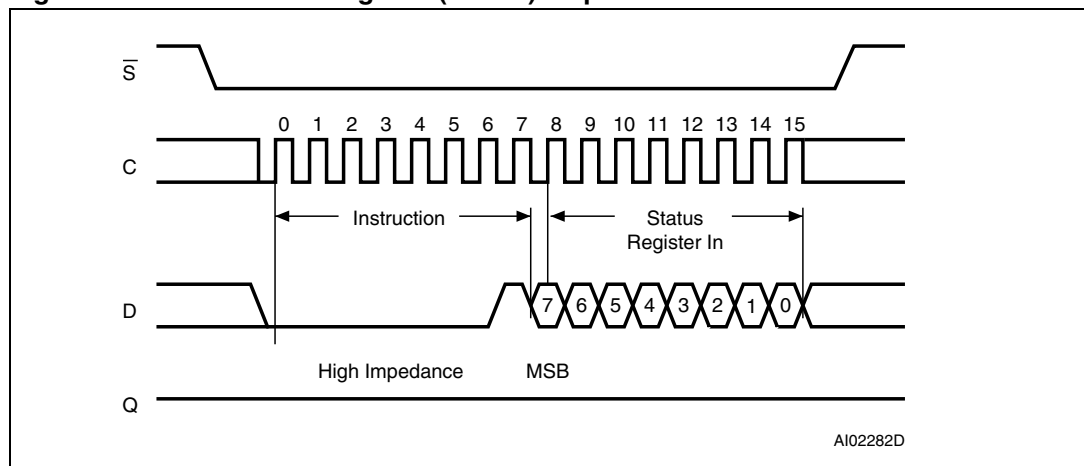

**Table 6. Protection modes**

$\overline{W}$ Signal	SRWD Bit	Mode	Write Protection of the Status Register	Memory content	
				Protected area <sup>(1)</sup>	Unprotected area <sup>(1)</sup>
1	0	Software Protected (SPM)	Status Register is Writable (if the WREN instruction has set the WEL bit)	Write Protected	Ready to accept Write instructions
0	0		The values in the BP1 and BP0 bits can be changed		
1	1				
0	1	Hardware Protected (HPM)	Status Register is Hardware write protected The values in the BP1 and BP0 bits cannot be changed	Write Protected	Ready to accept Write instructions

1. As defined by the values in the Block Protect (BP1, BP0) bits of the Status Register, as shown in [Table 2](#).

The protection features of the device are summarized in [Table 6](#).

When the Status Register Write Disable (SRWD) bit of the Status Register is 0 (its initial delivery state), it is possible to write to the Status Register (provided that the WEL bit has previously been set by a WREN instruction), regardless of the logic level applied on the Write Protect ( $\overline{W}$ ) input pin.

When the Status Register Write Disable (SRWD) bit of the Status Register is set to 1, two cases need to be considered, depending on the state of Write Protect ( $\overline{W}$ ) input pin:

- If Write Protect ( $\overline{W}$ ) is driven high, it is possible to write to the Status Register (provided that the WEL bit has previously been set by a WREN instruction).
- If Write Protect ( $\overline{W}$ ) is driven low, it is not possible to write to the Status Register even if the WEL bit has previously been set by a WREN instruction (attempts to write to the Status Register are rejected, and are not accepted for execution). As a consequence, all the data bytes in the memory area that are software-protected (SPM) by the Block Protect (BP1, BP0) bits in the Status Register, are also hardware-protected against data modification.

Regardless of the order of the two events, the Hardware-protected mode (HPM) can be entered either:

- by setting the SRWD bit after driving the Write Protect ( $\overline{W}$ ) input pin low
- or by driving the Write Protect ( $\overline{W}$ ) input pin low after setting the SRWD bit

Once entered, the Hardware-protected mode (HPM) can only be exited by pulling Write Protect ( $\overline{W}$ ) high.

If Write Protect ( $\overline{W}$ ) is permanently tied high, the Hardware-protected mode (HPM) can never be activated, and only the Software-protected mode (SPM) using the Block Protect (BP1, BP0) bits in the Status Register, can be used.

### 6.5 Read from Memory Array (READ)

As shown in *Figure 12*, to send this instruction to the device, Chip Select ( $\bar{S}$ ) is first driven low. The bits of the instruction byte and address bytes are then shifted in, on Serial Data Input (D). The address is loaded into an internal address register, and the byte of data at that address is shifted out, on Serial Data Output (Q).

If Chip Select ( $\bar{S}$ ) continues to be driven low, the internal address register is automatically incremented, and the byte of data at the new address is shifted out.

When the highest address is reached, the address counter rolls over to zero, allowing the Read cycle to be continued indefinitely. The whole memory can, therefore, be read with a single READ instruction.

The Read cycle is terminated by driving Chip Select ( $\bar{S}$ ) high. The rising edge of the Chip Select ( $\bar{S}$ ) signal can occur at any time during the cycle.

The first byte addressed can be any byte within any page.

The instruction is not accepted, and is not executed, if a Write cycle is currently in progress.

**Figure 12. Read from Memory Array (READ) sequence**

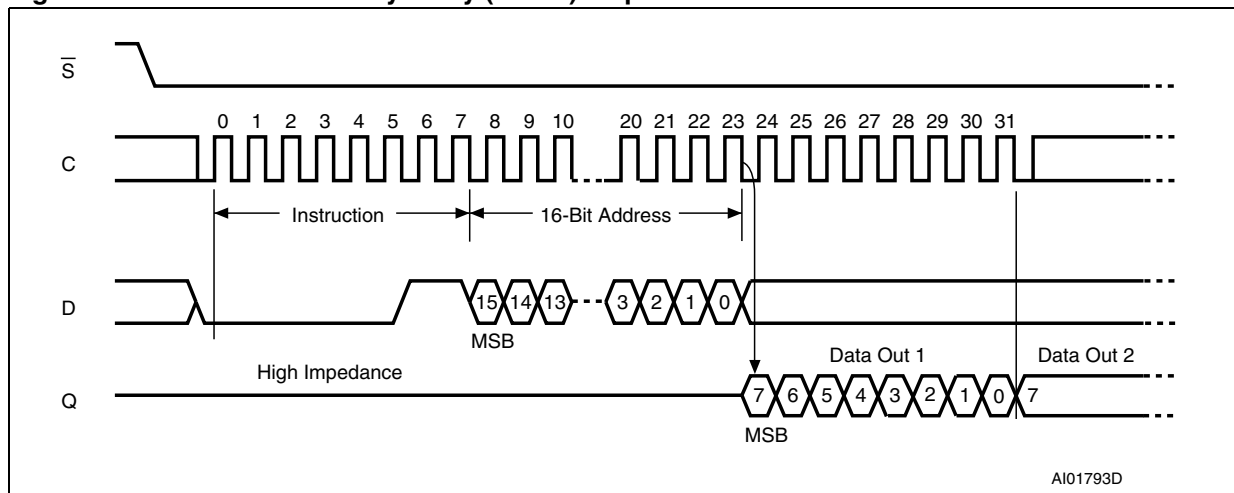

## 6.6 Write to Memory Array (WRITE)

As shown in *Figure 13*, to send this instruction to the device, Chip Select ( $\overline{S}$ ) is first driven low. The bits of the instruction byte, address byte, and at least one data byte are then shifted in, on Serial Data Input (D).

The instruction is terminated by driving Chip Select ( $\overline{S}$ ) high at a byte boundary of the input data. The self-timed Write cycle triggered by the rising edge of Chip Select ( $\overline{S}$ ) continues for a period  $t_W$  (as specified in *Table 16* and *Table 18*), at the end of which the Write in Progress (WIP) bit is reset to 0.

In the case of *Figure 13*, Chip Select ( $\overline{S}$ ) is driven high after the eighth bit of the data byte has been latched in, indicating that the instruction is being used to write a single byte. If, though, Chip Select ( $\overline{S}$ ) continues to be driven low, as shown in *Figure 14*., the next byte of input data is shifted in, so that more than a single byte, starting from the given address towards the end of the same page, can be written in a single internal write cycle.

Each time a new data byte is shifted in, the least significant bits of the internal address counter are incremented. If the number of data bytes sent to the device exceeds the page boundary, the internal address counter rolls over to the beginning of the page, and the previous data there are overwritten with the incoming data. (The page size of these devices is 128 bytes).

The instruction is not accepted, and is not executed, under the following conditions:

- if the Write Enable Latch (WEL) bit has not been set to 1 (by executing a Write Enable instruction just before)
- if a Write cycle is already in progress
- if the device has not been deselected, by Chip Select ( $\overline{S}$ ) being driven high, at a byte boundary (after the eighth bit, b0, of the last data byte that has been latched in)
- if the addressed page is in the region protected by the Block Protect (BP1 and BP0) bits.

*Note:* The self-timed write cycle  $t_W$  is internally executed as a sequence of two consecutive events: [Erase addressed byte(s)], followed by [Program addressed byte(s)]. An erased bit is read as "0" and a programmed bit is read as "1".

**Figure 13. Byte Write (WRITE) sequence**

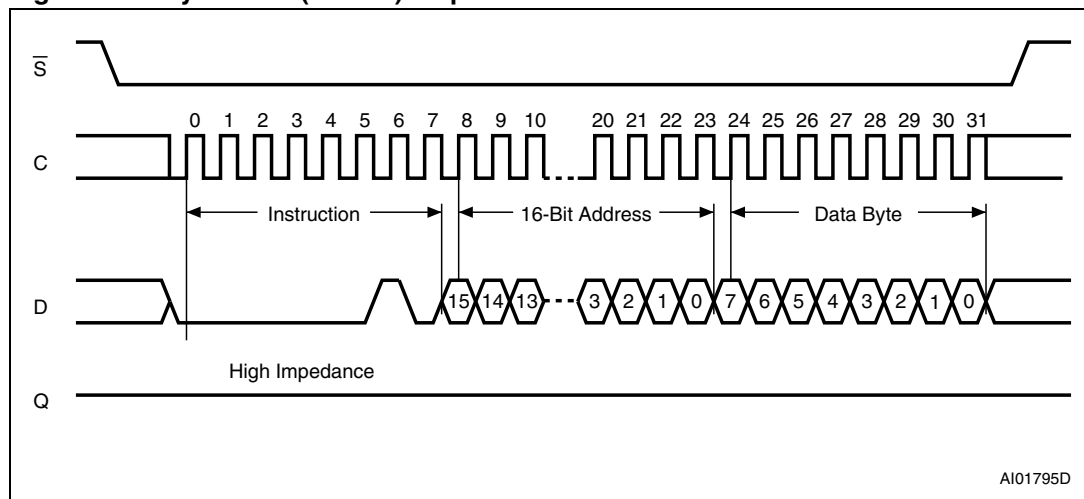
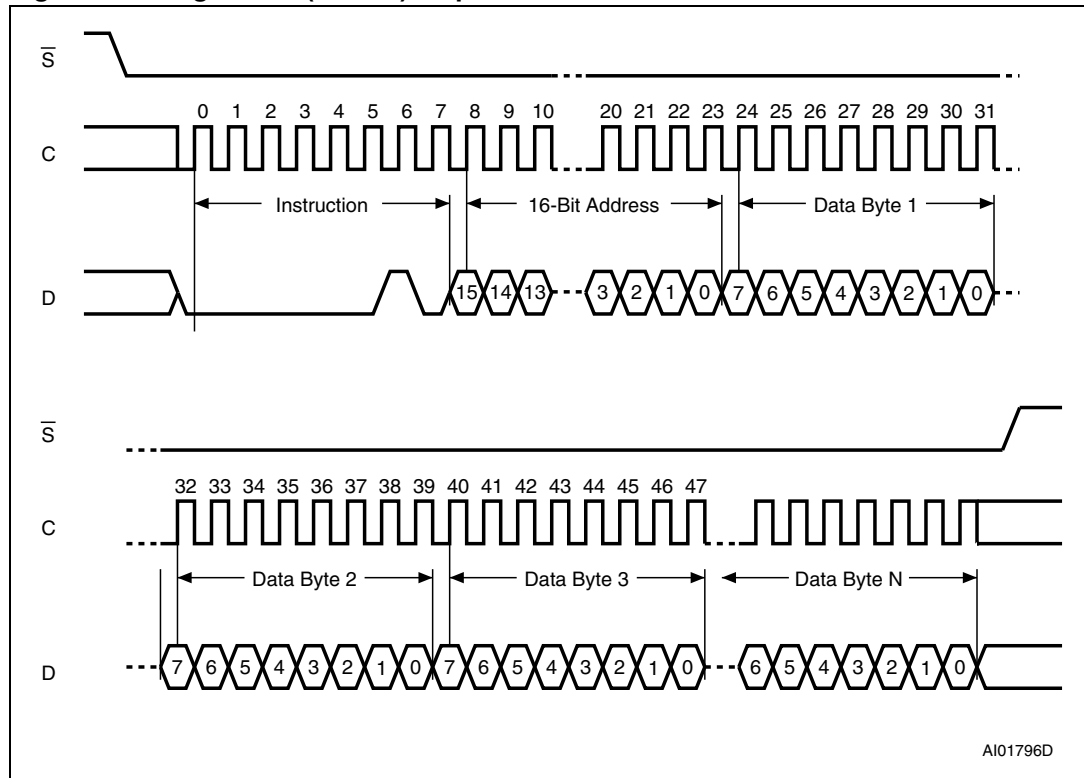

Figure 14. Page Write (WRITE) sequence





## 6.7 Read Identification Page (available only in M95512-DR devices)

The Identification Page (128 bytes) is an additional page which can be written and (later) permanently locked in Read-only mode.

Reading this page is achieved with the Read Identification Page instruction (see [Table 4](#)). The Chip Select signal (S) is first driven low, the bits of the instruction byte and address bytes are then shifted in, on Serial Data input (D). Address bit A10 must be 0, address bits [A15:A11] and [A9:A7] are Don't Care, and the data byte pointed to by [A6:A0] is shifted out on Serial Data output (Q).

If Chip Select (S) continues to be driven low, the internal address register is automatically incremented, and the byte of data at the new address is shifted out. The number of bytes to read in the ID page must not exceed the page boundary (e.g.: when reading the ID page from location 90d, the number of bytes should be less than or equal to 38d, as the ID page boundary is 128 bytes).

The read cycle is terminated by driving Chip Select ( $\bar{S}$ ) high. The rising edge of the Chip Select ( $\bar{S}$ ) signal can occur at any time during the cycle. The first byte addressed can be any byte within any page.

The instruction is not accepted, and is not executed, if a write cycle is currently in progress.

**Figure 15. Read Identification Page sequence**

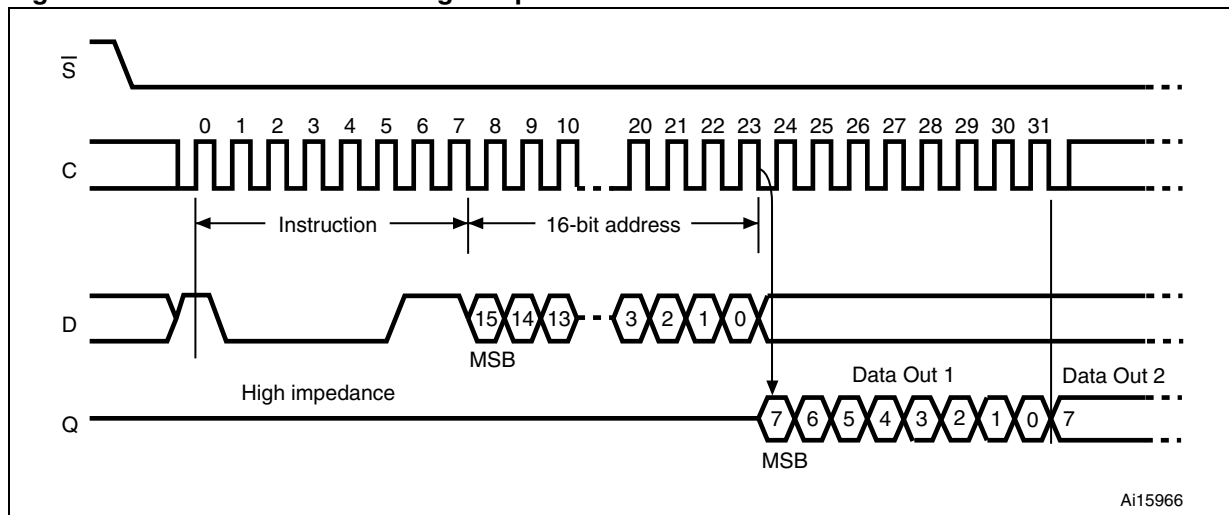

## 6.8 Write Identification Page (available only in M95512-DR devices)

The Identification Page (128 bytes) is an additional page which can be written and (later) permanently locked in Read-only mode. Writing this page is achieved with the Write Identification Page instruction (see [Table 4](#)), the Chip Select signal ( $\bar{S}$ ) is first driven low. The bits of the instruction byte, address byte, and at least one data byte are then shifted in on Serial Data input (D). Address bit A10 must be 0, address bits [A15:A11] and [A9:A7] are Don't Care, the [A6:A0] address bits define the byte address inside the identification page.

The instruction is terminated by driving Chip Select ( $\bar{S}$ ) high at a byte boundary of the input data. The self-timed write cycle triggered by the rising edge of Chip Select ( $\bar{S}$ ) continues for a period  $t_W$  (as specified in [Table 17](#) and [Table 18](#)), at the end of which the Write in Progress (WIP) bit is reset to 0.

In the case of [Figure 16](#), Chip Select ( $\bar{S}$ ) is driven high after the eighth bit of the data byte has been latched in, indicating that the instruction is being used to write a single byte. However, if Chip Select ( $\bar{S}$ ) continues to be driven low, as shown in [Figure 16](#), the next byte of input data is shifted in, so that more than a single byte, starting from the given address towards the end of the same page, can be written in a single internal write cycle. Each time a new data byte is shifted in, the least significant bits of the internal address counter are incremented. If the number of data bytes sent to the device exceeds the page boundary, the internal address counter rolls over to the beginning of the page, and the previous data there are overwritten with the incoming data. (The page size of these devices is 128 bytes).

The instruction is not accepted, and is not executed, under the following conditions:

- if the Write Enable Latch (WEL) bit has not been set to 1 (by previously executing a Write Enable instruction)
- if Status register bits (BP1, BP0) = (1, 1)
- if a write cycle is already in progress
- if the device has not been deselected, by Chip Select ( $\bar{S}$ ) being driven high, at a byte boundary (after the eighth bit, b0, of the last data byte that was latched in)
- if the Identification page is locked by the Lock Status bit

**Figure 16. Write Identification Page sequence**

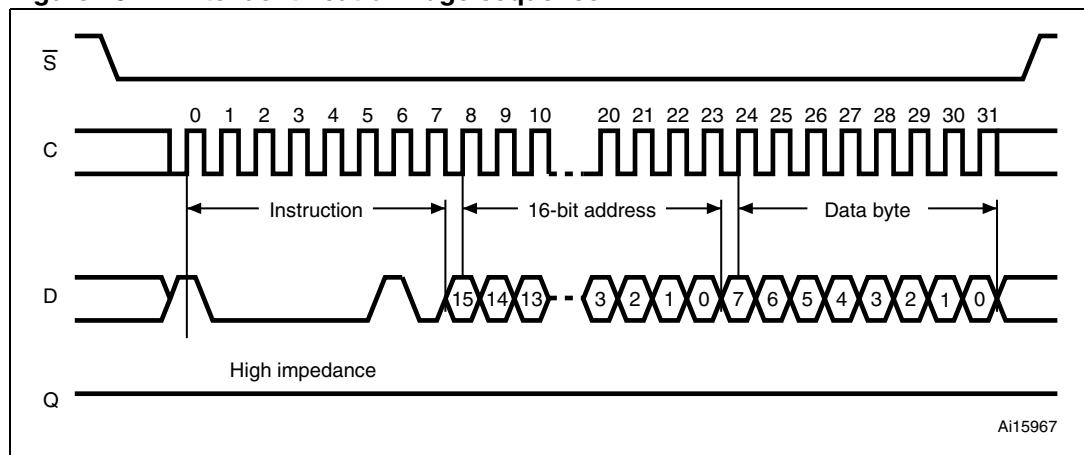

## 6.9 Read Lock Status (available only in M95512-DR devices)

The Read Lock Status instruction (see [Table 4](#)) allows to check if the Identification Page is locked (or not) in read-only mode. The Read Lock Status sequence is defined with the Chip Select ( $\bar{S}$ ) first driven low. The bits of the instruction byte and address bytes are then shifted in on Serial Data input (D). Address bit A10 must be 1, all other address bits are Don't Care.

The Lock bit is the LSB (least significant bit) of the byte read on Serial Data output (Q). It is at '1' when the lock is active and at '0' when the lock is not active. If Chip Select ( $\bar{S}$ ) continues to be driven low, the same data byte is shifted out. The read cycle is terminated by driving Chip Select ( $\bar{S}$ ) high.

The instruction sequence is shown in [Figure 17](#).

**Figure 17. Read Lock Status sequence**

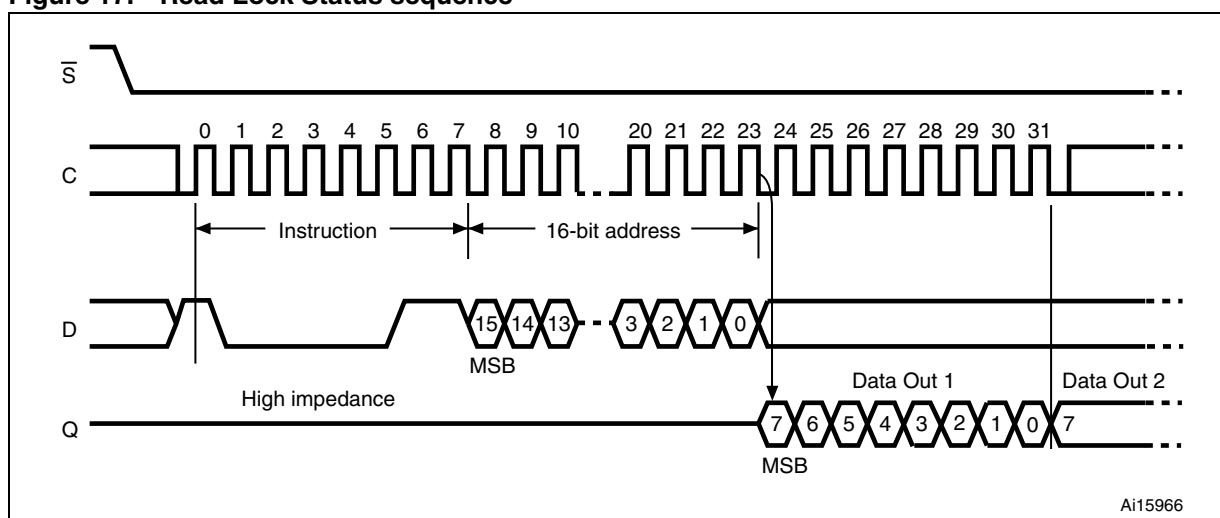

## 6.10 Lock ID (available only in M95512-DR devices)

The Lock ID instruction permanently locks the Identification Page in read-only mode. Before this instruction can be accepted, a Write Enable (WREN) instruction must have been executed. The Lock ID instruction is issued by driving Chip Select ( $\bar{S}$ ) low, sending the instruction code, the address and a data byte on Serial Data input (D), and driving Chip Select ( $\bar{S}$ ) high. In the address sent, A10 must be equal to 1, all other address bits are Don't Care. The data byte sent must be equal to the binary value xxxx xx1x, where x = Don't Care.

Chip Select ( $\bar{S}$ ) must be driven high after the rising edge of Serial Clock (C) that latches in the eighth bit of the data byte, and before the next rising edge of Serial Clock (C). Otherwise, the Lock ID instruction is not executed.

Driving Chip Select ( $\bar{S}$ ) high at a byte boundary of the input data triggers the self-timed write cycle whose duration is  $t_W$  (specified in [Table 17](#) and [Table 18](#)). The instruction sequence is shown in [Figure 18](#).

The instruction is not accepted, and so not executed, under the following conditions:

- if the Write Enable Latch (WEL) bit has not been set to 1 (by previously executing a Write Enable instruction)
- if Status register bits (BP1,BP0) = (1,1)
- if a write cycle is already in progress
- if the device has not been deselected, by Chip Select ( $\bar{S}$ ) being driven high, at a byte boundary (after the eighth bit, b0, of the last data byte that was latched in)
- if the Identification page is locked by the Lock Status bit

**Figure 18. Lock ID sequence**

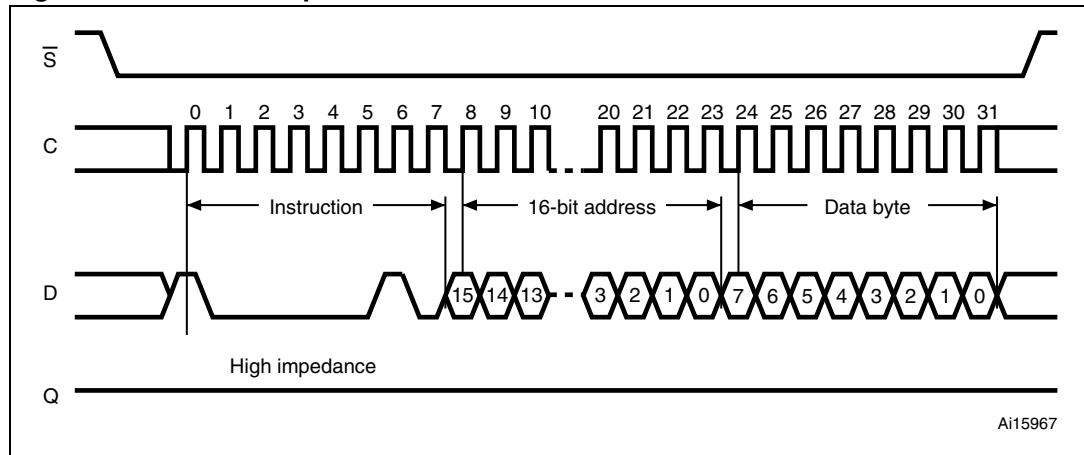

## 7 ECC (error correction code) and write cycling

The M95512-W, M95512-R and M95512-DR devices offer an ECC (error correction code) logic which compares each 4-byte word with its associated 6 EEPROM bits of ECC. As a result, if a single bit out of 4 bytes of data happens to be erroneous during a Read operation, the ECC detects it and replaces it by the correct value. The read reliability is therefore much improved by the use of this feature.

Note however that even if a single byte has to be written, 4 bytes are internally modified (plus the ECC bits), that is, the addressed byte is cycled together with the other three bytes making up the word. It is therefore recommended to write by words of 4 bytes in order to benefit from the larger amount of Write cycles.

The M95512-W, M95512-R and M95512-DR devices are qualified at 1 million (1 000 000) Write cycles, using a cycling routine that writes to the device by multiples of 4-byte packets.

## 8 Power-up and delivery state

### 8.1 Power-up state

After power-up, the device is in the following state:

- Standby Power mode
- Deselected (after Power-up, a falling edge is required on Chip Select ( $\bar{S}$ ) before any instructions can be started).
- Not in the Hold Condition
- Write Enable Latch (WEL) is reset to 0
- Write In Progress (WIP) is reset to 0

The SRWD, BP1 and BP0 bits of the Status Register are unchanged from the previous power-down (they are non-volatile bits).

### 8.2 Initial delivery state

The device is delivered with the memory array set at all 1s (FFh). The Status Register Write Disable (SRWD) and Block Protect (BP1 and BP0) bits are initialized to 0.

## 9 Maximum rating

Stressing the device outside the ratings listed in [Table 7](#) may cause permanent damage to the device. These are stress ratings only, and operation of the device at these, or any other conditions outside those indicated in the operating sections of this specification, is not implied. Exposure to absolute maximum rating conditions for extended periods may affect device reliability. Refer also to the STMicroelectronics SURE Program and other relevant quality documents.

**Table 7. Absolute maximum ratings**

Symbol	Parameter	Min.	Max.	Unit
	Ambient temperature with power applied	-40	130	°C
T <sub>STG</sub>	Storage temperature	-65	150	°C
T <sub>LEAD</sub>	Lead temperature during soldering	see note <sup>(1)</sup>		°C
V <sub>O</sub>	Output voltage	-0.50	V <sub>CC</sub> +0.6	V
V <sub>I</sub>	Input voltage	-0.50	6.5	V
I <sub>OL</sub>	DC output current (Q = 0)	-	5	mA
I <sub>OH</sub>	DC output current (Q = 1)	-5	-	mA
V <sub>CC</sub>	Supply voltage	-0.50	6.5	V
V <sub>ESD</sub>	Electrostatic discharge voltage (human body model) <sup>(2)</sup>	-3000	+3000	V

1. Compliant with JEDEC Std J-STD-020D (for small body, Sn-Pb or Pb assembly), the ST ECOPACK® 7191395 specification, and the European directive on Restrictions on Hazardous Substances (RoHS) 2002/95/EU.
2. AEC-Q100-002 (compliant with JEDEC Std JESD22-A114, C1=100pF, R1=1500 Ω, R2=500 Ω)

# 10 DC and AC parameters

This section summarizes the operating and measurement conditions, and the DC and AC characteristics of the device. The parameters in the DC and AC characteristic tables that follow are derived from tests performed under the measurement conditions summarized in the relevant tables. Designers should check that the operating conditions in their circuit match the measurement conditions when relying on the quoted parameters.

**Table 8. Operating conditions (M95512-W device grade 6)**

Symbol	Parameter	Min.	Max.	Unit
$V_{CC}$	Supply voltage	2.5	5.5	V
$T_A$	Ambient operating temperature (device grade 6)	-40	85	°C

**Table 9. Operating conditions (M95512-W device grade 3)**

Symbol	Parameter	Min.	Max.	Unit
$V_{CC}$	Supply voltage	2.5	5.5	V
$T_A$	Ambient operating temperature (device grade 6)	-40	125	°C

**Table 10. Operating conditions (M95512-R and M95512-DR)**

Symbol	Parameter	Min.	Max.	Unit
$V_{CC}$	Supply voltage	1.8	5.5	V
$T_A$	Ambient operating temperature	-40	85	°C

**Table 11. AC measurement conditions**

Symbol	Parameter	Min.	Max.	Unit
$C_L$	Load capacitance	30		pF
	Input Rise and Fall times		50	ns
	Input Pulse voltages	0.2 $V_{CC}$ to 0.8 $V_{CC}$		V
	Input and output timing reference voltages	0.3 $V_{CC}$ to 0.7 $V_{CC}$		V

**Figure 19. AC measurement I/O waveform**

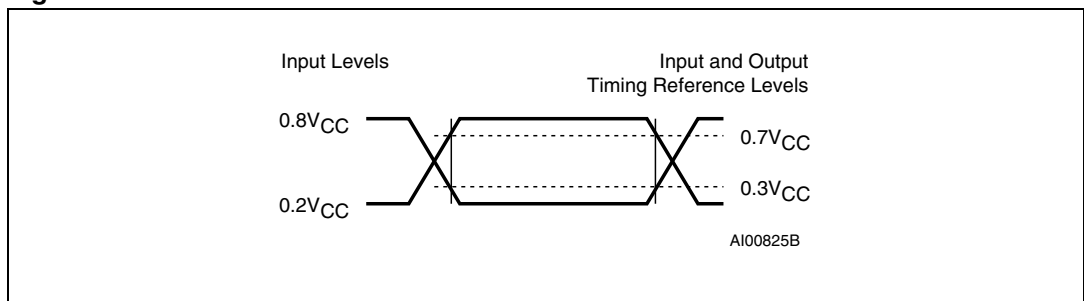

**Table 12. Capacitance<sup>(1)</sup>**

Symbol	Parameter	Test condition	Min.	Max.	Unit
C <sub>OUT</sub>	Output capacitance (Q)	V <sub>OUT</sub> = 0 V		8	pF
C <sub>IN</sub>	Input capacitance (D)	V <sub>IN</sub> = 0 V		8	pF
	Input capacitance (other pins)	V <sub>IN</sub> = 0 V		6	pF

1. Not 100% tested.

**Table 13. DC characteristics (current<sup>(1)</sup> M95512-W products)**

Symbol	Parameter	Test conditions: V <sub>CC</sub> = 2.5 to 5.5 V at T <sub>A</sub> = -40 to 85 °C (device grade 6) or T <sub>A</sub> = -40 to 125 °C (device grade 3)	Min.	Max.	Unit
I <sub>LI</sub>	Input leakage current	V <sub>IN</sub> = V <sub>SS</sub> or V <sub>CC</sub>		± 2	μA
I <sub>LO</sub>	Output leakage current	$\bar{S} = V_{CC}$ , V <sub>OUT</sub> = V <sub>SS</sub> or V <sub>CC</sub>		± 2	μA
I <sub>CC</sub>	Supply current (Read)	C = 0.1V <sub>CC</sub> /0.9V <sub>CC</sub> at 5 MHz, V <sub>CC</sub> = 2.5 V, Q = open		3	mA
		C = 0.1V <sub>CC</sub> /0.9V <sub>CC</sub> at 5 MHz, V <sub>CC</sub> = 5 V, Q = open		5	mA
I <sub>CC0</sub> <sup>(2)</sup>	Supply current (Write)	During t <sub>W</sub> , $\bar{S} = V_{CC}$ , 2.5 V < V <sub>CC</sub> < 5.5 V		6	mA
I <sub>CC1</sub>	Supply current (Standby Power mode)	$\bar{S} = V_{CC}$ , V <sub>IN</sub> = V <sub>SS</sub> or V <sub>CC</sub> , 2.5 V < V <sub>CC</sub> < 5.5 V		5	μA
V <sub>IL</sub>	Input low voltage		-0.45	0.3 V <sub>CC</sub>	V
V <sub>IH</sub>	Input high voltage		0.7 V <sub>CC</sub>	V <sub>CC</sub> +1	V
V <sub>OL</sub>	Output low voltage	V <sub>CC</sub> = 2.5 V and I <sub>OL</sub> = 1.5 mA or V <sub>CC</sub> = 5 V and I <sub>OL</sub> = 2 mA		0.4	V
V <sub>OH</sub>	Output high voltage	V <sub>CC</sub> = 2.5 V and I <sub>OH</sub> = -0.4 mA or V <sub>CC</sub> = 5 V and I <sub>OH</sub> = -2 mA	0.8 V <sub>CC</sub>		V

1. Current products are identified by AB process letters AB.

2. Characterized value, not tested in production.



Table 14. DC characteristics (new<sup>(1)</sup> M95512-W products)

Symbol	Parameter	Test conditions: $V_{CC} = 2.5$ to $5.5$ V, $T_A = -40$ to $85$ °C	Min.	Max.	Unit
$I_{LI}$	Input leakage current	$V_{IN} = V_{SS}$ or $V_{CC}$		$\pm 2$	$\mu$ A
$I_{LO}$	Output leakage current	$\bar{S} = V_{CC}$ , $V_{OUT} = V_{SS}$ or $V_{CC}$		$\pm 2$	$\mu$ A
$I_{CC}$	Supply current (Read)	$C = 0.1V_{CC}/0.9V_{CC}$ at 10 MHz, $V_{CC} = 2.5$ V, Q = open		4	mA
		$C = 0.1V_{CC}/0.9V_{CC}$ at 20 MHz, $V_{CC} = 5$ V, Q = open		8	mA
$I_{CC0}^{(2)}$	Supply current (Write)	During $t_W$ , $\bar{S} = V_{CC}$ , $2.5$ V < $V_{CC} < 5.5$ V		6	mA
$I_{CC1}$	Supply current (Standby Power mode)	$\bar{S} = V_{CC}$ , $V_{IN} = V_{SS}$ or $V_{CC}$ , $2.5$ V < $V_{CC} < 5.5$ V		5	$\mu$ A
$V_{IL}$	Input low voltage		-0.45	$0.3 V_{CC}$	V
$V_{IH}$	Input high voltage		$0.7 V_{CC}$	$V_{CC}+1$	V
$V_{OL}$	Output low voltage	$V_{CC} = 2.5$ V and $I_{OL} = 1.5$ mA or $V_{CC} = 5$ V and $I_{OL} = 2$ mA		0.4	V
$V_{OH}$	Output high voltage	$V_{CC} = 2.5$ V and $I_{OH} = -0.4$ mA or $V_{CC} = 5$ V and $I_{OH} = -2$ mA	$0.8 V_{CC}$		V

1. New products are identified by process letter K.
2. Characterized value, not tested in production.

Table 15. DC characteristics (current and new M95512-R and M95512-DR products)

Symbol	Parameter	Test conditions: $V_{CC} = 1.8$ to $5.5$ V, $T_A = -40$ to $85$ °C	Min	Max	Unit
$I_{LI}$	Input leakage current	$V_{IN} = V_{SS}$ or $V_{CC}$		$\pm 2$	$\mu$ A
$I_{LO}$	Output leakage current	$\bar{S} = V_{CC}$ , $V_{OUT} = V_{SS}$ or $V_{CC}$		$\pm 2$	$\mu$ A
$I_{CC}$	Supply current (Read)	$C = 0.1V_{CC}/0.9V_{CC}$ at 2 MHz, $V_{CC} = 1.8$ V, Q = open <sup>(1)</sup>		1	mA
		$C = 0.1V_{CC}/0.9V_{CC}$ at 5 MHz, $V_{CC} = 1.8$ V, Q = open <sup>(2)</sup>		2.5	mA
$I_{CC0}^{(3)}$	Supply current (Write)	During $t_W$ , $\bar{S} = V_{CC}$ , $1.8$ V < $V_{CC} < 2.5$ V		3	mA
$I_{CC1}$	Supply current (Standby Power mode)	$\bar{S} = V_{CC}$ , $V_{IN} = V_{SS}$ or $V_{CC}$ , $1.8$ V < $V_{CC} < 2.5$ V		3	$\mu$ A
$V_{IL}$	Input low voltage		-0.45	$0.3 V_{CC}$	V
$V_{IH}$	Input high voltage		$0.7 V_{CC}$	$V_{CC}+1$	V
$V_{OL}$	Output low voltage	$I_{OL} = 0.15$ mA, $V_{CC} = 1.8$ V		0.3	V
$V_{OH}$	Output high voltage	$I_{OH} = -0.1$ mA, $V_{CC} = 1.8$ V	$0.8 V_{CC}$		V

1. Current products are identified by process letters AB.
2. New products are identified by process letter K.
3. Characterized value, not tested in production.

**Table 16. AC characteristics (current<sup>(1)</sup> M95512-W products)**

Test conditions: V <sub>CC</sub> = 2.5 to 5.5 V at T <sub>A</sub> = -40 to 85 °C (device grade 6) or T <sub>A</sub> = -40 to 125 °C (device grade 3)					
Symbol	Alt.	Parameter	Min.	Max.	Unit
f <sub>C</sub>	f <sub>SCK</sub>	Clock frequency	D.C.	5	MHz
t <sub>SLCH</sub>	t <sub>CSS1</sub>	$\overline{S}$ active setup time	90		ns
t <sub>SHCH</sub>	t <sub>CSS2</sub>	$\overline{S}$ not active setup time	90		ns
t <sub>SHSL</sub>	t <sub>CS</sub>	$\overline{S}$ deselect time	100		ns
t <sub>CHSH</sub>	t <sub>CSH</sub>	$\overline{S}$ active hold time	90		ns
t <sub>CHSL</sub>		$\overline{S}$ not active hold time	90		ns
t <sub>CH</sub> <sup>(2)</sup>	t <sub>CLH</sub>	Clock high time	90		ns
t <sub>CL</sub> <sup>(2)</sup>	t <sub>CLL</sub>	Clock low time	90		ns
t <sub>CLCH</sub> <sup>(3)</sup>	t <sub>RC</sub>	Clock rise time		1	μs
t <sub>CHCL</sub> <sup>(3)</sup>	t <sub>FC</sub>	Clock fall time		1	μs
t <sub>DVCH</sub>	t <sub>DSU</sub>	Data in setup time	20		ns
t <sub>CHDX</sub>	t <sub>DH</sub>	Data in hold time	30		ns
t <sub>HHCH</sub>		Clock low hold time after $\overline{HOLD}$ not active	70		ns
t <sub>HLCH</sub>		Clock low hold time after $\overline{HOLD}$ active	40		ns
t <sub>CLHL</sub>		Clock low setup time before $\overline{HOLD}$ active	0		ns
t <sub>CLHH</sub>		Clock low setup time before $\overline{HOLD}$ not active	0		ns
t <sub>SHQZ</sub> <sup>(3)</sup>	t <sub>DIS</sub>	Output disable time		100	ns
t <sub>CLQV</sub>	t <sub>V</sub>	Clock low to output valid		60	ns
t <sub>CLQX</sub>	t <sub>HO</sub>	Output hold time	0		ns
t <sub>QLQH</sub> <sup>(3)</sup>	t <sub>RO</sub>	Output rise time		50	ns
t <sub>QHQL</sub> <sup>(3)</sup>	t <sub>FO</sub>	Output fall time		50	ns
t <sub>HHQV</sub>	t <sub>LZ</sub>	$\overline{HOLD}$ high to output valid		50	ns
t <sub>HLQZ</sub> <sup>(3)</sup>	t <sub>HZ</sub>	$\overline{HOLD}$ low to output High-Z		100	ns
t <sub>W</sub>	t <sub>WC</sub>	Write time		5	ms

1. Current products are identified by process letters AB.
2. t<sub>CH</sub> + t<sub>CL</sub> must never be less than the shortest possible clock period, 1 / f<sub>C</sub>(max)
3. Value guaranteed by characterization, not 100% tested in production.

Table 17. AC characteristics (New<sup>(1)</sup> M95512-W products)

Test conditions: $V_{CC} = 2.5$ to $5.5$ V, $T_A = -40$ to $85$ °C							
Symbol	Alt.	Parameter	Min.	Max.	Min.	Max.	Unit
			2.5 V to 5.5 V		4.5 V to 5.5 V		
$f_C$	$f_{SCK}$	Clock frequency	D.C.	10	D.C.	20	MHz
$t_{SLCH}$	$t_{CSS1}$	$\overline{S}$ active setup time	30		15		ns
$t_{SHCH}$	$t_{CSS2}$	$\overline{S}$ not active setup time	30		15		ns
$t_{SHSL}$	$t_{CS}$	$\overline{S}$ deselect time	40		20		ns
$t_{CHSH}$	$t_{CSH}$	$\overline{S}$ active hold time	30		15		ns
$t_{CHSL}$		$\overline{S}$ not active hold time	30		15		ns
$t_{CH}^{(2)}$	$t_{CLH}$	Clock high time	45		20		ns
$t_{CL}^{(2)}$	$t_{CLL}$	Clock low time	45		20		ns
$t_{CLCH}^{(3)}$	$t_{RC}$	Clock rise time		2		2	$\mu$ s
$t_{CHCL}^{(3)}$	$t_{FC}$	Clock fall time		2		2	$\mu$ s
$t_{DVCH}$	$t_{DSU}$	Data in setup time	10		5		ns
$t_{CHDX}$	$t_{DH}$	Data in hold time	10		10		ns
$t_{HHCH}$		Clock low hold time after $\overline{HOLD}$ not active	30		15		ns
$t_{HLCH}$		Clock low hold time after $\overline{HOLD}$ active	30		15		ns
$t_{CLHL}$		Clock low setup time before $\overline{HOLD}$ active	0		0		ns
$t_{CLHH}$		Clock low setup time before $\overline{HOLD}$ not active	0		0		ns
$t_{SHQZ}^{(3)}$	$t_{DIS}$	Output disable time		40		20	ns
$t_{CLQV}$	$t_V$	Clock low to output valid		40		20	ns
$t_{CLQX}$	$t_{HO}$	Output hold time	0		0		ns
$t_{QLQH}^{(3)}$	$t_{RO}$	Output rise time		40		20	ns
$t_{QHQL}^{(3)}$	$t_{FO}$	Output fall time		40		20	ns
$t_{HHQV}$	$t_{LZ}$	$\overline{HOLD}$ high to output valid		40		20	ns
$t_{HLQZ}^{(3)}$	$t_{HZ}$	$\overline{HOLD}$ low to output High-Z		40		20	ns
$t_W$	$t_{WC}$	Write time		5		5	ms

1. New products are identified by process letter K.
2.  $t_{CH} + t_{CL}$  must never be less than the shortest possible clock period,  $1 / f_C(\max)$
3. Value guaranteed by characterization, not 100% tested in production.

Table 18. AC characteristics (current and new M95512-R and M95512-DR products)

Test conditions: $V_{CC} = 1.8$ to $5.5$ V, $T_A = -40$ to $85$ °C							
Symbol	Alt.	Parameter	Min.	Max.	Min.	Max.	Unit
			Current <sup>(1)</sup> products		New products <sup>(2)</sup>		
$f_C$	$f_{SCK}$	Clock frequency	D.C.	2	D.C.	5	MHz
$t_{SLCH}$	$t_{CSS1}$	$\overline{S}$ active setup time	200		60		ns
$t_{SHCH}$	$t_{CSS2}$	$\overline{S}$ not active setup time	200		60		ns
$t_{SHSL}$	$t_{CS}$	$\overline{S}$ deselect time	200		90		ns
$t_{CHSH}$	$t_{CSH}$	$\overline{S}$ active hold time	200		60		ns
$t_{CHSL}$		$\overline{S}$ not active hold time	200		60		ns
$t_{CH}^{(3)}$	$t_{CLH}$	Clock high time	200		80		ns
$t_{CL}^{(3)}$	$t_{CLL}$	Clock low time	200		80		ns
$t_{CLCH}^{(4)}$	$t_{RC}$	Clock rise time		1		2	$\mu$ s
$t_{CHCL}^{(4)}$	$t_{FC}$	Clock fall time		1		2	$\mu$ s
$t_{DVCH}$	$t_{DSU}$	Data in setup time	40		20		ns
$t_{CHDX}$	$t_{DH}$	Data in hold time	50		20		ns
$t_{HHCH}$		Clock low hold time after $\overline{HOLD}$ not active	140		60		ns
$t_{HLCH}$		Clock low hold time after $\overline{HOLD}$ active	90		60		ns
$t_{CLHL}$		Clock low setup time before $\overline{HOLD}$ active	0		0		ns
$t_{CLHH}$		Clock low setup time before $\overline{HOLD}$ not active	0		0		ns
$t_{SHQZ}^{(4)}$	$t_{DIS}$	Output disable time		250		80	ns
$t_{CLQV}$	$t_V$	Clock low to output valid		150		80	ns
$t_{CLQX}$	$t_{HO}$	Output hold time	0		0		ns
$t_{QLQH}^{(4)}$	$t_{RO}$	Output rise time		100		80	ns
$t_{QHQL}^{(4)}$	$t_{FO}$	Output fall time		100		80	ns
$t_{HHQV}$	$t_{LZ}$	$\overline{HOLD}$ high to output valid		100		80	ns
$t_{HLQZ}^{(4)}$	$t_{HZ}$	$\overline{HOLD}$ low to output High-Z		250		80	ns
$t_W$	$t_{WC}$	Write time		5		5	ms

1. Current products are identified by process letters "AB".
2. New products are identified by process letter K. For these new products, the test flow guarantees the AC parameter values defined in this table (when  $V_{CC} = 1.8$  V) and the AC parameter values defined in [Table 17](#) (when  $V_{CC} = 2.5$  V or  $V_{CC} = 5.0$  V).
3.  $t_{CH} + t_{CL}$  must never be less than the shortest possible clock period,  $1 / f_C(\max)$
4. Value guaranteed by characterization, not 100% tested in production.

Figure 20. Serial input timing

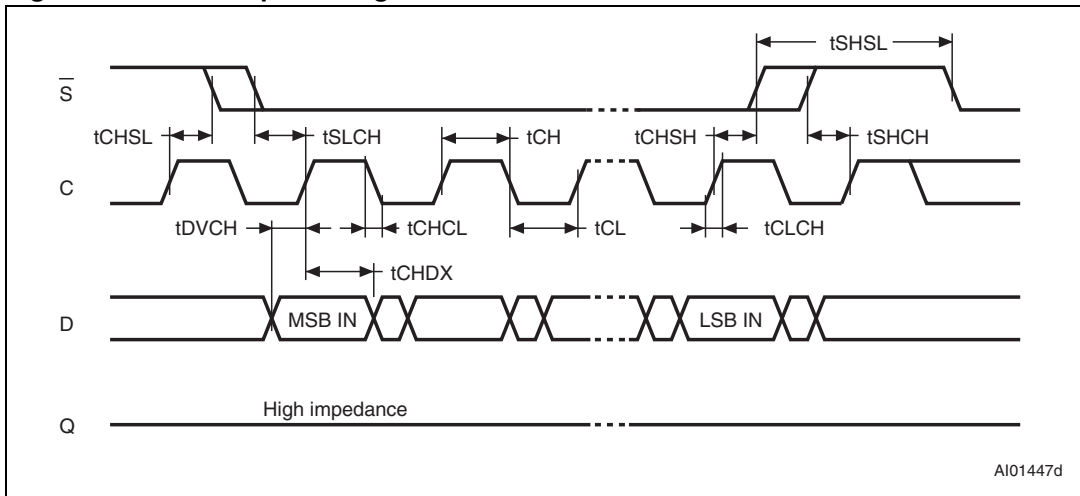

AI01447d

Figure 21. Hold timing

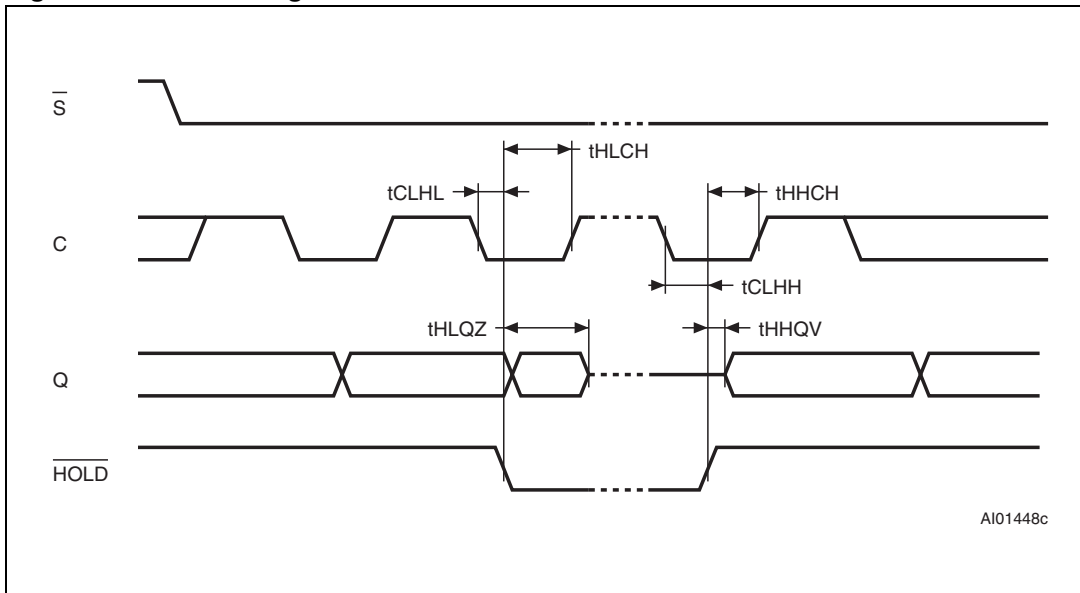

AI01448c

Figure 22. Serial output timing

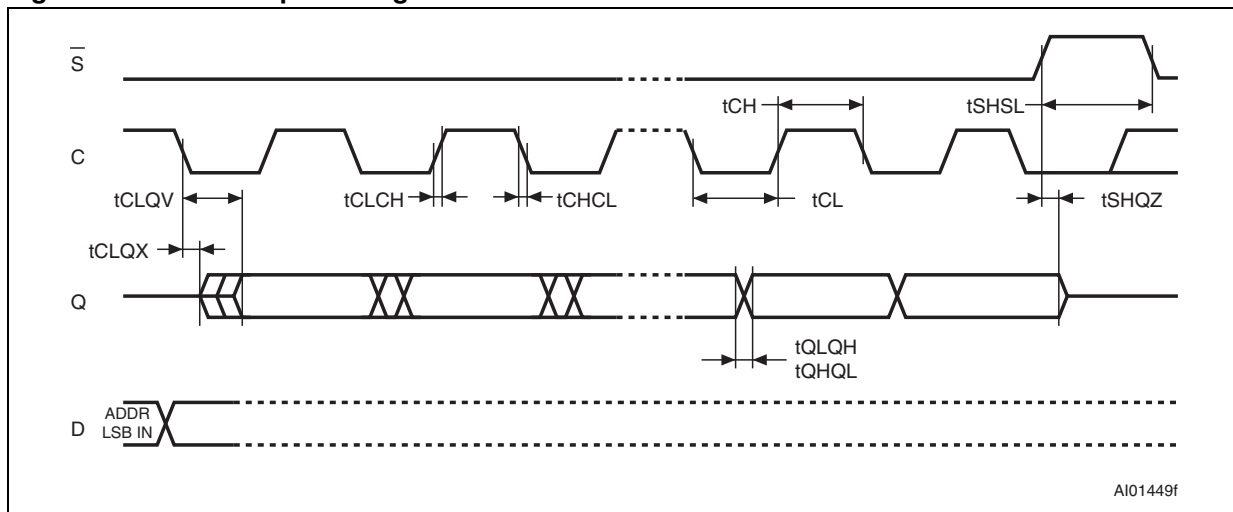

# 11 Package mechanical data

In order to meet environmental requirements, ST offers these devices in different grades of ECOPACK® packages, depending on their level of environmental compliance. ECOPACK® specifications, grade definitions and product status are available at: [www.st.com](http://www.st.com). ECOPACK® is an ST trademark.

**Figure 23. SO8N – 8 lead plastic small outline, 150 mils body width, package outline**

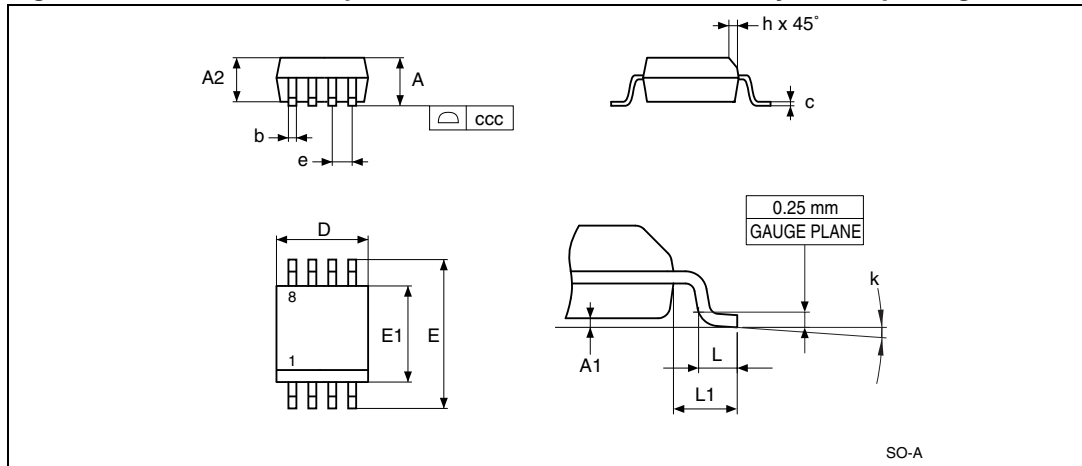

1. Drawing is not to scale.

**Table 19. SO8N – 8 lead plastic small outline, 150 mils body width, package mechanical data**

Symbol	millimeters			inches <sup>(1)</sup>		
	Typ	Min	Max	Typ	Min	Max
A			1.75			0.0689
A1		0.10	0.25		0.0039	0.0098
A2		1.25			0.0492	
b		0.28	0.48		0.011	0.0189
c		0.17	0.23		0.0067	0.0091
ccc			0.10			0.0039
D	4.90	4.80	5.00	0.1929	0.189	0.1969
E	6.00	5.80	6.20	0.2362	0.2283	0.2441
E1	3.90	3.80	4.00	0.1535	0.1496	0.1575
e	1.27	–	–	0.05	-	-
h		0.25	0.50		0.0098	0.0197
k		0°	8°		0°	8°
L		0.40	1.27		0.0157	0.05
L1	1.04			0.0409		

1. Values in inches are converted from mm and rounded to 4 decimal digits.

Figure 24. TSSOP8 – 8 lead thin shrink small outline, package outline

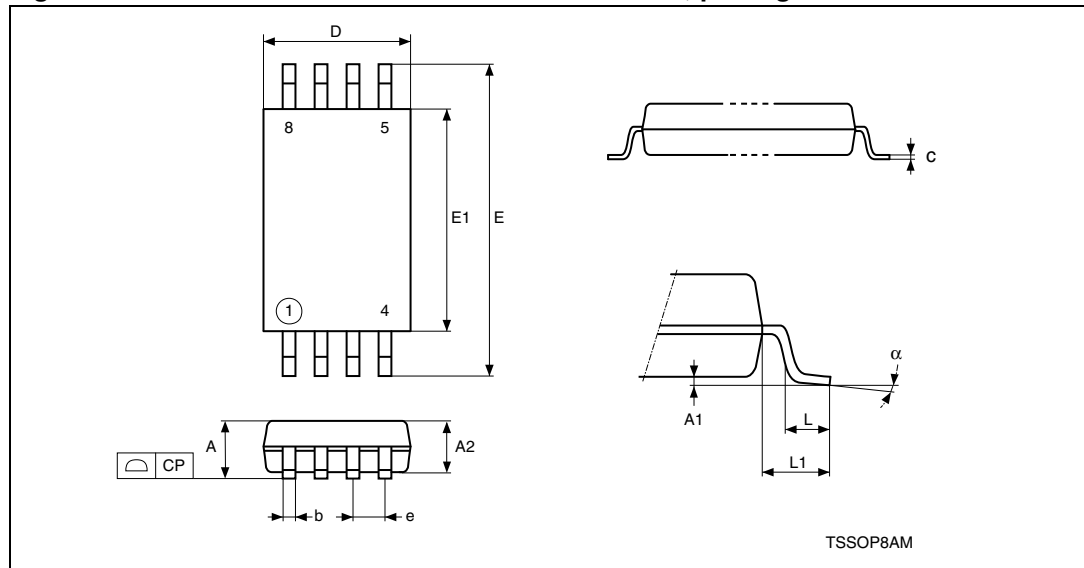

1. Drawing is not to scale.
2. The central pad (area E2 by D2 in the above illustration) is internally pulled to VSS. It must not be connected to any other voltage or signal line on the PCB, for example during the soldering process.

Table 20. TSSOP8 – 8 lead thin shrink small outline, package mechanical data

Symbol	millimeters			inches <sup>(1)</sup>		
	Typ	Min	Max	Typ	Min	Max
A			1.200			0.0472
A1		0.050	0.150		0.0020	0.0059
A2	1.000	0.800	1.050	0.0394	0.0315	0.0413
b		0.190	0.300		0.0075	0.0118
c		0.090	0.200		0.0035	0.0079
CP			0.100			0.0039
D	3.000	2.900	3.100	0.1181	0.1142	0.1220
e	0.650	–	–	0.0256	–	–
E	6.400	6.200	6.600	0.2520	0.2441	0.2598
E1	4.400	4.300	4.500	0.1732	0.1693	0.1772
L	0.600	0.450	0.750	0.0236	0.0177	0.0295
L1	1.000			0.0394		
alpha		0°	8°		0°	8°
N	8			8		

1. Values in inches are converted from mm and rounded to 4 decimal digits.



**Figure 25. UFDFPN8 (MLP8) – 8-lead ultra thin fine pitch dual flat package no lead 2 × 3 mm, package outline**

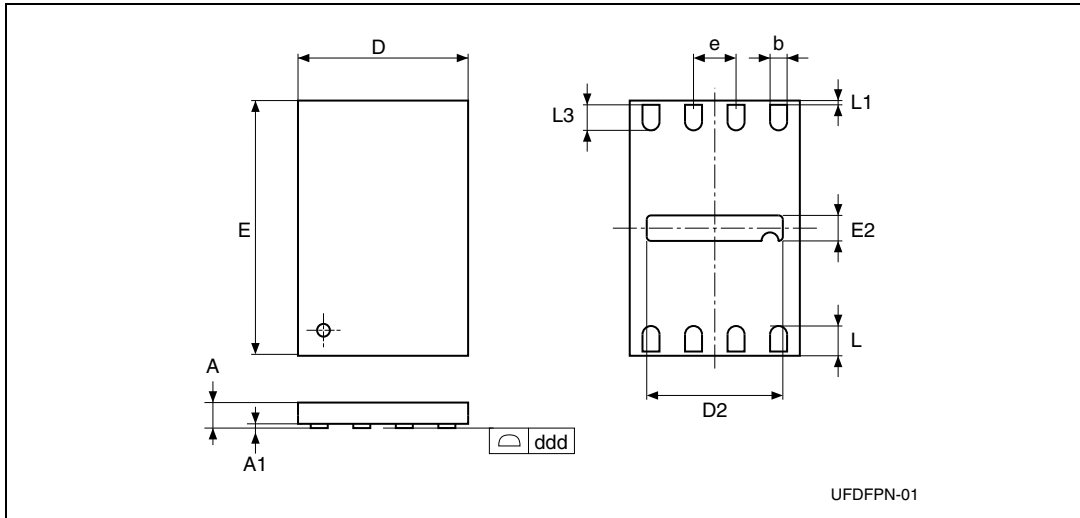

1. Drawing is not to scale.
2. The central pad (the area E2 by D2 in the above illustration) is internally pulled to VSS. It must not be connected to any other voltage or signal line on the PCB, for example during the soldering process.

**Table 21. UFDFPN8 (MLP8) – 8-lead ultra thin fine pitch dual flat package no lead 2 × 3 .mm, package mechanical data**

Symbol	millimeters			inches <sup>(1)</sup>		
	Typ	Min	Max	Typ	Min	Max
A	0.55	0.50	0.60	0.0217	0.0197	0.0236
A1	0.02	0.00	0.05	0.0008	0	0.0020
b	0.25	0.20	0.30	0.0098	0.0079	0.0118
D	2.00	1.90	2.10	0.0787	0.0748	0.0827
D2	1.60	1.50	1.70	0.0630	0.0591	0.0669
ddd			0.08			0.0031
E	3.00	2.90	3.10	0.1181	0.1142	0.1220
E2	0.20	0.10	0.30	0.0079	0.0039	0.0118
e	0.50	–	–	0.0197	–	–
L	0.45	0.40	0.50	0.0177	0.0157	0.0197
L1			0.15			0.0059
L3		0.30			0.0118	

1. Values in inches are converted from mm and rounded to 4 decimal digits.

Figure 26. WLCSP-R – 8-bump wafer-length chip-scale package outline

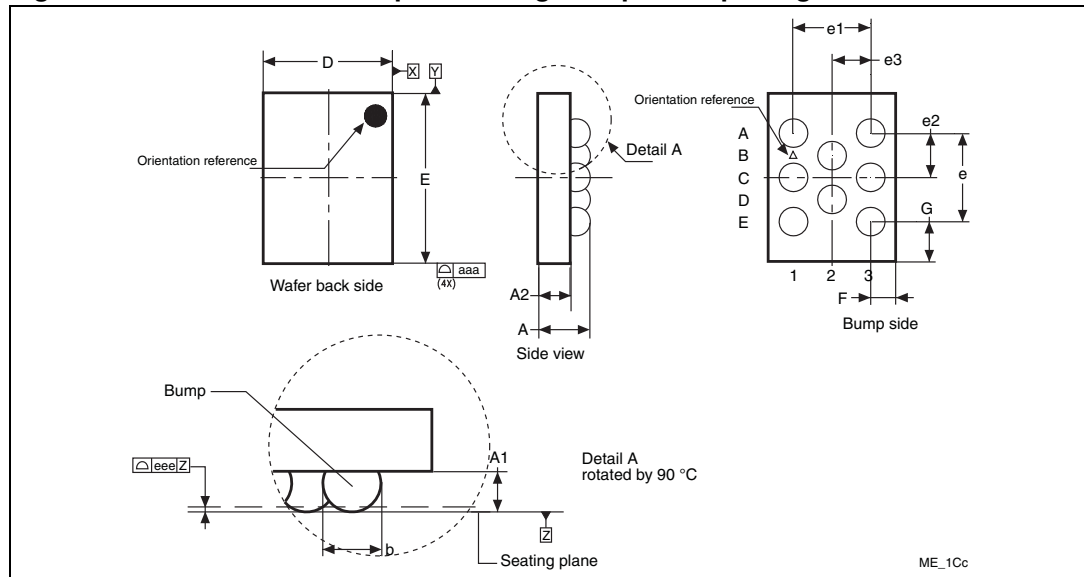

1. Drawing is not to scale.

Table 22. WLCSP-R – 8-bump wafer-length chip-scale package mechanical data

Symbol	millimeters			inches <sup>(1)</sup>		
	Typ	Min	Max	Typ	Min	Max
A	0.580	0.490	0.670	0.0228	0.0193	0.0264
A1	0.230			0.0091		
A2	0.350			0.0138		
b <sup>(2)</sup>	0.322			0.0127		
D	1.433		1.548	0.0564		0.0609
E	1.901		2.016	0.0748		0.0794
e	1.000			0.0394		
e1	0.866			0.0341		
e2	0.500			0.0197		
e3	0.433			0.0170		
F	0.284			0.0112		
G	0.453			0.0178		
N (number of terminals)	8			8		
aaa		0.110			0.0043	
eee		0.060			0.0024	

1. Values in inches are converted from mm and rounded to 4 decimal digits.

2. Measured at the maximum bump diameter parallel to primary datum Z.

# 12 Part numbering

**Table 23. Ordering information scheme**

Example:	M95512	-	W	MN	6	T	P	/AB
<b>Device type</b>								
M95 = SPI serial access EEPROM								
<b>Device function</b>								
512 = 512 Kbit (65536 × 8)								
512-D = 512 Kbit (65536 × 8) plus Identification page								
<b>Operating voltage</b>								
W = V <sub>CC</sub> = 2.5 V to 5.5 V								
R = V <sub>CC</sub> = 1.8 V to 5.5 V								
<b>Package</b>								
MN = SO8 (150 mil width)								
DW = TSSOP8 (169 mil width)								
MB = UFDFPN8 (MLP8)								
CS = WLCSP								
<b>Device grade</b>								
6 = Industrial temperature range, -40 to 85 °C. Device tested with standard test flow								
3 = Device tested with high reliability certified flow <sup>(1)</sup> . Automotive temperature range (-40 to 125 °C)								
<b>Option</b>								
blank = Standard packing								
T = Tape and reel packing								
<b>Plating technology</b>								
P or G = ECOPACK <sup>®</sup> (RoHS compliant)								
<b>Process<sup>(2)</sup></b>								
/AB = F8L								
/K = F8H								

1. ST strongly recommends the use of the automotive grade devices for use in an automotive environment. The high reliability certified flow (HRCF) is described in the quality note QNEE9801. Please ask your nearest ST sales office for a copy.

2. The process letters only appear in the product ordering codes of device grade 3 devices. For other devices, it is only given here as an indication of how to differentiate current from new products. To identify current from new devices, please contact your nearest ST sales office.

For a list of available options (speed, package, etc.) or for further information on any aspect of this device, please contact your nearest ST sales office.

**Table 24. Available M95512 products (package, voltage range, temperature grade)**

Package	M95512-W 2.5 V to 5.5 V	M95512-R 1.8 V to 5.5 V
SO8 (MN)	Range 6, range 3	Range 6
TSSOP (DW)	Range 6	Range 6
UFDFPN8 (MB)	-	Range 6
WLCSP (CS)	-	Range 6

**Table 25. Available M95512-DR products (package, voltage range, temperature grade)**

Package	M95512-DR 1.8 V to 5.5 V
SO8 (MN)	Range 6
TSSOP (DW)	Range 6

## 13 Revision history

**Table 26. Document revision history**

Date	Revision	Changes
Jan-1999	1.0	Document written
13-Feb-2002	2.0	Document reformatted using the new template Voltage range -S added, and -R removed Instruction Sequence illustrations updated Announcement made of planned upgrade to 10 MHz clock for the 5V, -40 to 85°C, range
05-Dec-2003	3.0	Table of contents, and Pb-free options added. $V_{IL}$ (min) improved to -0.45V. Voltage range -R added, and -S removed
02-Apr-2004	4.0	Old versions of document completely replaced by one rewritten from M95256
03-Jan-2005	5.0	AC and DC characteristics tables updated with the performance data of the new device identified with the process letter "A". <a href="#">Table 1.</a> , <a href="#">Product List</a> added. AEC-Q100-002 compliance. Device Grade information clarified. $t_{HHQX}$ , $t_{CHHL}$ and $t_{CHHH}$ corrected to $t_{HHQV}$ , $t_{CLHL}$ and $t_{CLHH}$ , respectively. M95512 part number with 4.5V to 5.5V operating voltage range removed (related tables removed). Document status changed to Preliminary Data.
30-Jun-2005	6.0	Updated <a href="#">Figure 4: Bus master and memory devices on the SPI bus</a> and <a href="#">Figure 21: Hold timing. Power On Reset</a> information clarified. Protected Array Addresses modified in <a href="#">Table 2: Write-protected block size</a> . Ambient Operating Temperature value added in <a href="#">Table 7: Absolute maximum ratings</a> . Supply Current ( $I_{CC}$ ) value modified for 10 MHz in <a href="#">Table 13: DC characteristics (current M95512-W products)</a> . All values modified in <a href="#">Table 18: AC characteristics (current and new M95512-R and M95512-DR products)</a> . Document status changed to Datasheet.

Table 26. Document revision history (continued)

Date	Revision	Changes
06-Feb-2007	7	<p>Document reformatted. Packages are ECOPACK® compliant. 10 MHz frequency removed. <i>VCC supply voltage</i> and <i>VSS ground</i> descriptions added. <i>Figure 4: Bus master and memory devices on the SPI bus</i> modified and explanatory paragraph added. Power-up and Power On Reset paragraphs replaced by <i>Section 4.1: Supply voltage (VCC)</i>. <i>Section 7: ECC (error correction code) and write cycling</i> added.</p> <p><math>T_A</math> max modified in <i>Table 8: Operating conditions (M95512-W device grade 6)</i>.</p> <p>Note modified below <i>Table 12: Capacitance</i>.</p> <p><math>C_L</math> modified in and <i>Table 11: AC measurement conditions</i>.</p> <p><math>V_{IL}</math> max and <math>I_{CC0}</math> test conditions modified in <i>Table 15: DC characteristics (current and new M95512-R and M95512-DR products)</i>.</p> <p><math>I_{CC}</math> modified in <i>Table 13: DC characteristics (current M95512-W products)</i>, <math>I_{CC0}</math> added to <i>Table 13</i> and <i>Table 15: DC characteristics (current and new M95512-R and M95512-DR products)</i> modified.</p> <p><i>Table 18: AC characteristics (current and new M95512-R and M95512-DR products)</i> modified.</p> <p><math>t_{SHQZ}</math> end timing line moved back in <i>Figure 22: Serial output timing</i>.</p> <p>SO8N package specifications updated (see <i>Figure 23</i> and <i>Table 19</i>).</p> <p>Blank removed below <i>Plating technology</i> in <i>Table 23: Ordering information scheme</i>.</p>
05-Jun-2007	8	<p>The device endurance is specified at more than 1 000 000 (1 million) cycles (corrected on cover page).</p>
03-Jul-2008	9	<p>M95512-W is now available in the device grade 3 (automotive temperature range), see <i>Table 8 on page 31</i>.</p> <p><i>Section 4.1: Supply voltage (VCC) on page 12</i> updated.</p> <p><i>Section 6.4: Write Status Register (WRSR) on page 20</i> and <i>Section 6.6: Write to Memory Array (WRITE) on page 23</i> clarified.</p> <p><math>I_{CC0}</math> modified in <i>Table 13: DC characteristics (current M95512-W products)</i>.</p> <p><i>Figure 20: Serial input timing</i>, <i>Figure 21: Hold timing</i> and <i>Figure 22: Serial output timing</i> updated.</p> <p>Package mechanical data values in inches are calculated from the millimeter values and rounded to four decimal digits (see <i>Section 11: Package mechanical data</i>).</p> <p><i>Table 24: Available M95512 products (package, voltage range, temperature grade)</i> added. Small text changes.</p>
14-Apr-2009	10	<p>M95512-DR part number added (see <i>Table 25: Available M95512-DR products (package, voltage range, temperature grade)</i>).</p> <p>New M95512-W, M95512-R and M95512-DR products operating at up to 20 MHz added (preliminary data).</p> <p>UFDFPN8 package added (see <i>Section 11: Package mechanical data</i>).</p>

Table 26. Document revision history (continued)

Date	Revision	Changes
11-May-2009	11	<p><math>V_{ESD}</math> modified in <a href="#">Table 7: Absolute maximum ratings</a>.</p> <p>Updated:</p> <ul style="list-style-type: none"> <li>– <a href="#">Section 6.7: Read Identification Page (available only in M95512-DR devices)</a></li> <li>– <a href="#">Section 6.8: Write Identification Page (available only in M95512-DR devices)</a></li> <li>– <a href="#">Section 6.9: Read Lock Status (available only in M95512-DR devices)</a></li> <li>– <a href="#">Section 6.10: Lock ID (available only in M95512-DR devices)</a></li> </ul>
28-Aug-2009	12	<p>Data related to new products are no longer preliminary.</p> <p><a href="#">Note 2</a> updated in <a href="#">Table 18: AC characteristics (current and new M95512-R and M95512-DR products)</a>.</p>
14-Sep-2010	13	<p>WLCSP package added.</p> <p>M95512-DR added.</p> <p>Updated:</p> <ul style="list-style-type: none"> <li>– <a href="#">Section 1: Description</a></li> <li>– <a href="#">Section 6.7: Read Identification Page (available only in M95512-DR devices)</a></li> <li>– <a href="#">Section 6.8: Write Identification Page (available only in M95512-DR devices)</a></li> <li>– <a href="#">Section 6.9: Read Lock Status (available only in M95512-DR devices)</a>, <a href="#">Table 7: Absolute maximum ratings</a></li> </ul> <p>Inserted Caution under <a href="#">Table 1: Signal names</a></p> <p>Added Note under <a href="#">Figure 24: TSSOP8 – 8 lead thin shrink small outline, package outline</a></p>

**Please Read Carefully:**

Information in this document is provided solely in connection with ST products. STMicroelectronics NV and its subsidiaries ("ST") reserve the right to make changes, corrections, modifications or improvements, to this document, and the products and services described herein at any time, without notice.

All ST products are sold pursuant to ST's terms and conditions of sale.

Purchasers are solely responsible for the choice, selection and use of the ST products and services described herein, and ST assumes no liability whatsoever relating to the choice, selection or use of the ST products and services described herein.

No license, express or implied, by estoppel or otherwise, to any intellectual property rights is granted under this document. If any part of this document refers to any third party products or services it shall not be deemed a license grant by ST for the use of such third party products or services, or any intellectual property contained therein or considered as a warranty covering the use in any manner whatsoever of such third party products or services or any intellectual property contained therein.

**UNLESS OTHERWISE SET FORTH IN ST'S TERMS AND CONDITIONS OF SALE ST DISCLAIMS ANY EXPRESS OR IMPLIED WARRANTY WITH RESPECT TO THE USE AND/OR SALE OF ST PRODUCTS INCLUDING WITHOUT LIMITATION IMPLIED WARRANTIES OF MERCHANTABILITY, FITNESS FOR A PARTICULAR PURPOSE (AND THEIR EQUIVALENTS UNDER THE LAWS OF ANY JURISDICTION), OR INFRINGEMENT OF ANY PATENT, COPYRIGHT OR OTHER INTELLECTUAL PROPERTY RIGHT.**

**UNLESS EXPRESSLY APPROVED IN WRITING BY AN AUTHORIZED ST REPRESENTATIVE, ST PRODUCTS ARE NOT RECOMMENDED, AUTHORIZED OR WARRANTED FOR USE IN MILITARY, AIR CRAFT, SPACE, LIFE SAVING, OR LIFE SUSTAINING APPLICATIONS, NOR IN PRODUCTS OR SYSTEMS WHERE FAILURE OR MALFUNCTION MAY RESULT IN PERSONAL INJURY, DEATH, OR SEVERE PROPERTY OR ENVIRONMENTAL DAMAGE. ST PRODUCTS WHICH ARE NOT SPECIFIED AS "AUTOMOTIVE GRADE" MAY ONLY BE USED IN AUTOMOTIVE APPLICATIONS AT USER'S OWN RISK.**

Resale of ST products with provisions different from the statements and/or technical features set forth in this document shall immediately void any warranty granted by ST for the ST product or service described herein and shall not create or extend in any manner whatsoever, any liability of ST.

ST and the ST logo are trademarks or registered trademarks of ST in various countries.

Information in this document supersedes and replaces all information previously supplied.

The ST logo is a registered trademark of STMicroelectronics. All other names are the property of their respective owners.

© 2010 STMicroelectronics - All rights reserved

STMicroelectronics group of companies

Australia - Belgium - Brazil - Canada - China - Czech Republic - Finland - France - Germany - Hong Kong - India - Israel - Italy - Japan - Malaysia - Malta - Morocco - Philippines - Singapore - Spain - Sweden - Switzerland - United Kingdom - United States of America

[www.st.com](http://www.st.com)