

Hex Schmitt inverter

Features

- High speed:
 $t_{PD} = 12 \text{ ns}$ (typ.) at $V_{CC} = 6 \text{ V}$
- Low power dissipation:
 $I_{CC} = 1 \mu\text{A}$ (max.) at $T_A = 25 \text{ }^\circ\text{C}$
- High noise immunity:
 $V_H = 1.2 \text{ V}$ (typ.) at $V_{CC} = 6 \text{ V}$
- Symmetrical output impedance:
 $|I_{OH}| = I_{OL} = 4 \text{ mA}$ (min.)
- Balanced propagation delays:
 $t_{PLH} \cong t_{PHL}$
- Wide operating voltage range:
 $V_{CC} \text{ (opr)} = 2 \text{ to } 6 \text{ V}$
- Pin and function compatible with 74 series 14

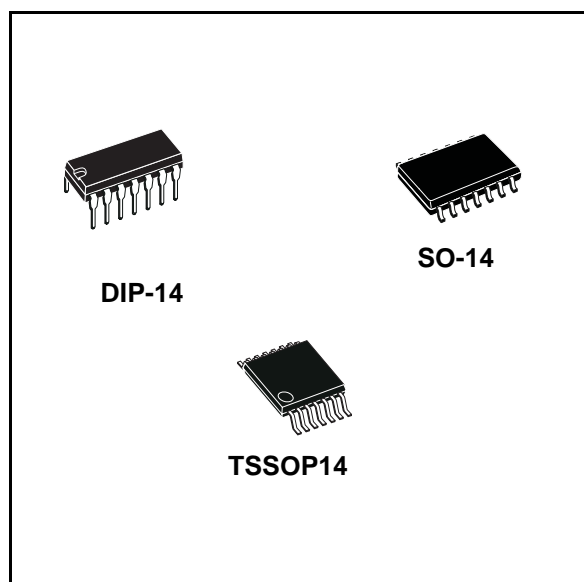

Description

The M74HC14 is a high speed CMOS hex Schmitt inverter fabricated with silicon gate C²MOS technology. Pin configuration and functions are the same as those of the M74HC04 but all the inputs have 20% V_{CC} hysteresis level.

This, together with its Schmitt trigger function, allows the device to be used on line receivers with slow rise/fall input signals.

All inputs are equipped with protection circuits against static discharge and transient excess voltage.

Table 1. Device summary

Order code	Package	Packaging
M74HC14B1R	DIP-14	Tube
M74HC14RM13TR	SO-14	Tape and reel
M74HC14TTR	TSSOP14	Tape and reel

1 Pin connection and IEC logic symbols

Figure 1. Pin connections and IEC logic symbols

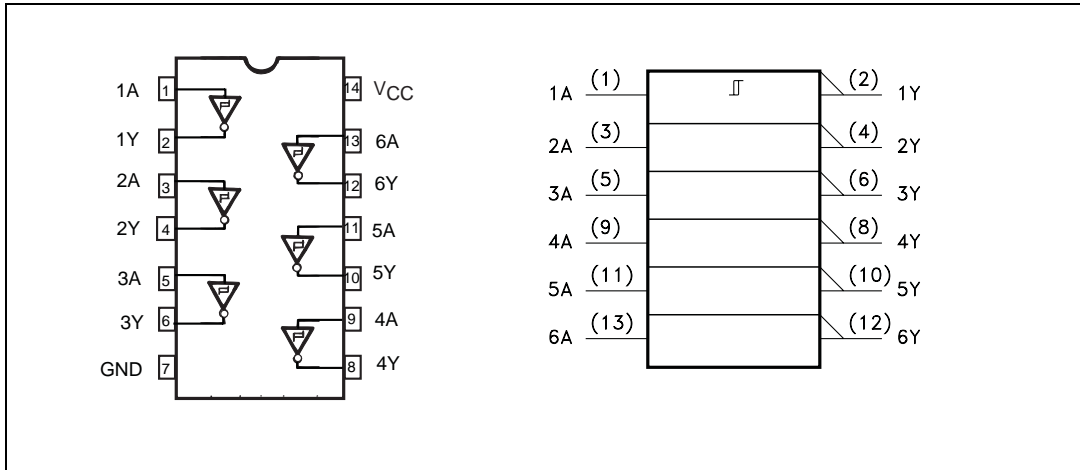

Table 2. Pin description

Pin number	Symbol	Name and function
1, 3, 5, 9, 11, 13	1A to 6A	Data inputs
2, 4, 6, 8, 10, 12	1Y to 6Y	Data outputs
7	GND	Ground (0 V)
14	V _{CC}	Positive supply voltage

Figure 2. Input and output equivalent circuit

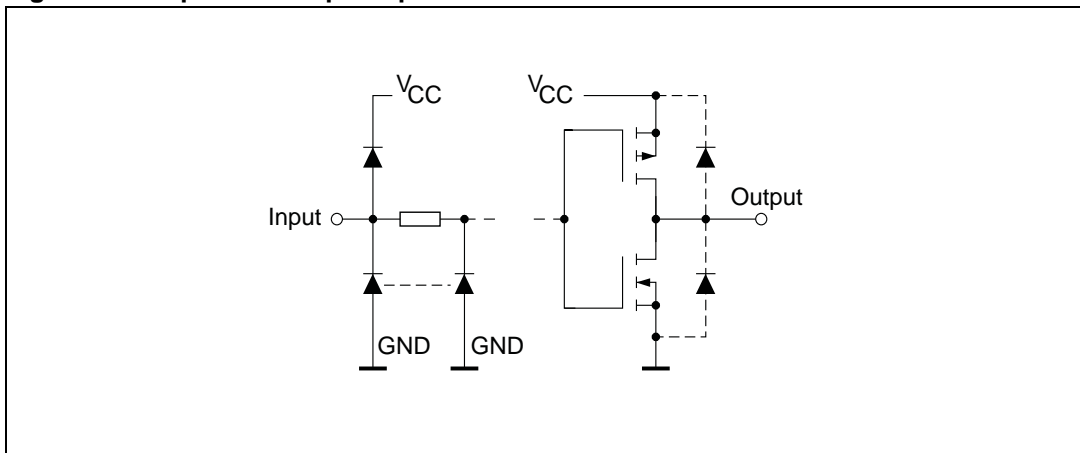

Table 3. Truth table

A	Y
L	H
H	L

2 Maximum rating

Stressing the device above the rating listed in the “Absolute maximum ratings” table may cause permanent damage to the device. These are stress ratings only, and operation of the device at these or any other conditions above those indicated in the operating sections of this specification is not implied. Exposure to absolute maximum rating conditions for extended periods may affect device reliability. Refer also to the STMicroelectronics SURE Program and other relevant quality documents.

Table 4. Absolute maximum ratings

Symbol	Parameter	Value	Unit
V_{CC}	Supply voltage	-0.5 to +7	V
V_I	DC input voltage	-0.5 to $V_{CC} + 0.5$	V
V_O	DC output voltage	-0.5 to $V_{CC} + 0.5$	V
I_{IK}	DC input diode current	± 20	mA
I_{OK}	DC output diode current	± 20	mA
I_O	DC output current	± 25	mA
I_{CC} or I_{GND}	DC V_{CC} or Ground current	± 50	mA
P_D	Power dissipation	500 ⁽¹⁾	mW
T_{stg}	Storage temperature	-65 to +150	°C
T_L	Lead temperature (10 sec)	300	°C

1. 500 mW at 65 °C; derate to 300 mW by 10 mW/°C from 65 °C to 85 °C

2.1 Recommended operating conditions

Table 5. Recommended operating conditions

Symbol	Parameter	Value	Unit
V_{CC}	Supply voltage	2 to 6	V
V_I	Input voltage	0 to V_{CC}	V
V_O	Output voltage	0 to V_{CC}	V
T_{op}	Operating temperature	-55 to 125	°C

3 Electrical characteristics

Table 6. DC specifications

Symbol	Parameter	Test condition		Value						Unit	
		V _{CC} (V)		T _A = 25°C			-40 to 85°C		-55 to 125°C		
				Min	Typ	Max	Min	Max	Min		Max
V _{t+}	High level input voltage	2.0		1.0	1.28	1.5	1.0	1.5	1.0	1.5	V
		4.5		2.3	2.8	3.15	2.3	3.15	2.3	3.15	
		6.0		3.0	3.7	4.2	3.0	4.2	3.0	4.2	
V _{t-}	Low level input voltage	2.0		0.3	0.74	0.9	0.3	0.9	0.3	0.9	V
		4.5		1.13	1.8	2.0	1.13	2.0	1.13	2.0	
		6.0		1.5	2.4	2.6	1.5	2.6	1.5	2.6	
V _H	Hysteresis voltage	2.0		0.3	0.54	1.0	0.3	1.0	0.3	1.0	V
		4.5		0.6	1.0	1.4	0.6	1.4	0.6	1.4	
		6.0		0.8	1.3	1.4	0.8	1.7	0.8	1.7	
V _{OH}	High level output voltage	2.0	I _O = -20 μA	1.9	2.0		1.9		1.9		V
		4.5	I _O = -20 μA	4.4	4.5		4.4		4.4		
		6.0	I _O = -20 μA	5.9	6.0		5.9		5.9		
		4.5	I _O = -4.0 mA	4.18	4.31		4.13		4.10		
		6.0	I _O = -5.2 mA	5.68	5.8		5.63		5.60		
V _{OL}	Low level output voltage	2.0	I _O = -20 μA		0.0	0.1		0.1		0.1	V
		4.5	I _O = -20 μA		0.0	0.1		0.1		0.1	
		6.0	I _O = -20 μA		0.0	0.1		0.1		0.1	
		4.5	I _O = -4.0 mA		0.17	0.26		0.33		0.40	
		6.0	I _O = -5.2 mA		0.18	0.26		0.33		0.40	
I _I	Input leakage current	6.0	V _I = V _{CC} or GND			±0.1		±1		±1	μA
I _{CC}	Quiescent supply current	6.0	V _I = V _{CC} or GND			1		10		20	μA

Table 7. AC electrical characteristics ($C_L = 50$ pF, Input $t_r = t_f = 6$ ns)

Symbol	Parameter	Test condition		Value						Unit	
		V_{CC} (V)		$T_A = 25\text{ }^\circ\text{C}$			-40 to $85\text{ }^\circ\text{C}$		-55 to $125\text{ }^\circ\text{C}$		
				Min	Typ	Max	Min	Max	Min		Max
t_{TLH} t_{THL}	Output transition time	2.0			30	75		95		110	ns
		4.5			8	15		19		22	
		6.0			7	13		16		19	
t_{PLH} t_{PHL}	Propagation delay time	2.0			42	125		155		190	ns
		4.5			14	25		31		38	
		6.0			12	21		16		32	

Table 8. Capacitive characteristics

Symbol	Parameter	Test condition		Value						Unit	
		V_{CC} (V)		$T_A = 25\text{ }^\circ\text{C}$			-40 to $85\text{ }^\circ\text{C}$		-55 to $125\text{ }^\circ\text{C}$		
				Min	Typ	Max	Min	Max	Min		Max
C_{IN}	Input capacitance	5.0			5	10		10		10	pF
C_{PD}	Power dissipation capacitance ⁽¹⁾	5.0	$f_{IN} = 10$ MHz		28						pF

1. C_{PD} is defined as the value of the IC's internal equivalent capacitance which is calculated from the operating current consumption without load. (Refer to test circuit). Average operating current can be obtained by the following equation:
 $I_{CC(oper)} = C_{PD} \times V_{CC} \times f_{IN} + I_{CC}/6(\text{per gate})$.

Figure 3. Test circuit

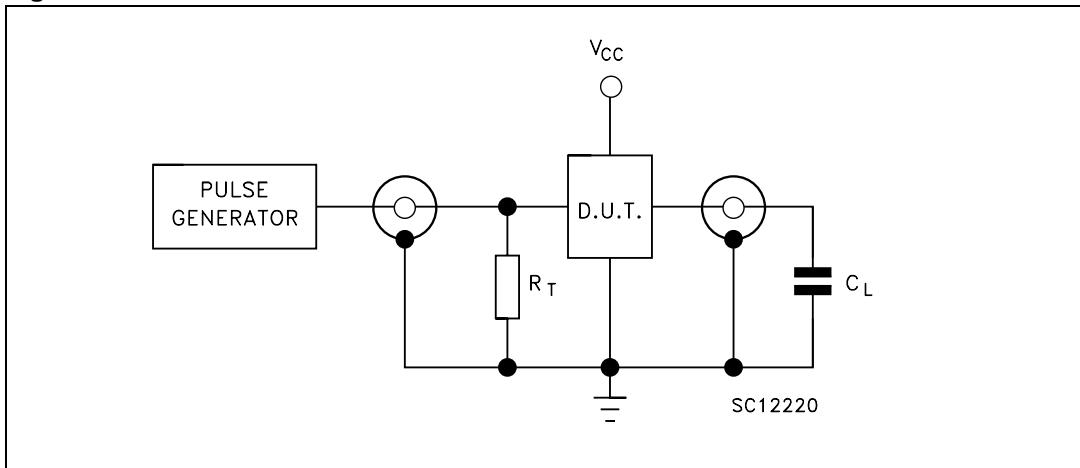
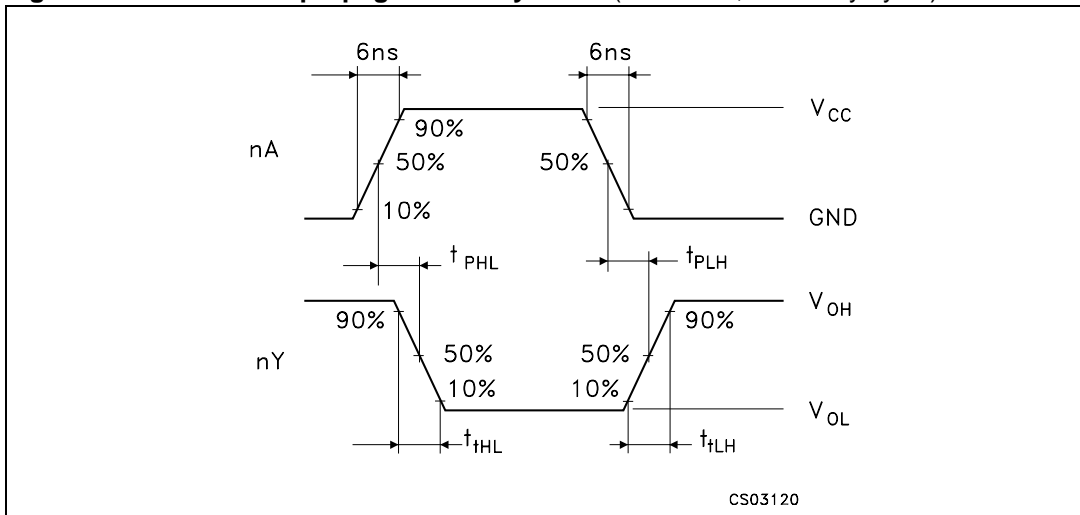

Figure 4. Waveform: propagation delay times ($f = 1$ MHz; 50% duty cycle)



4 Package mechanical data

In order to meet environmental requirements, ST offers these devices in ECOPACK® packages. These packages have a Lead-free second level interconnect. The category of second level interconnect is marked on the package and on the inner box label, in compliance with JEDEC Standard JESD97. The maximum ratings related to soldering conditions are also marked on the inner box label. ECOPACK is an ST trademark. ECOPACK specifications are available at: www.st.com.

Plastic DIP-14 MECHANICAL DATA

DIM.	mm.			inch		
	MIN.	TYP	MAX.	MIN.	TYP.	MAX.
a1	0.51			0.020		
B	1.39		1.65	0.055		0.065
b		0.5			0.020	
b1		0.25			0.010	
D			20			0.787
E		8.5			0.335	
e		2.54			0.100	
e3		15.24			0.600	
F			7.1			0.280
I			5.1			0.201
L		3.3			0.130	
Z	1.27		2.54	0.050		0.100

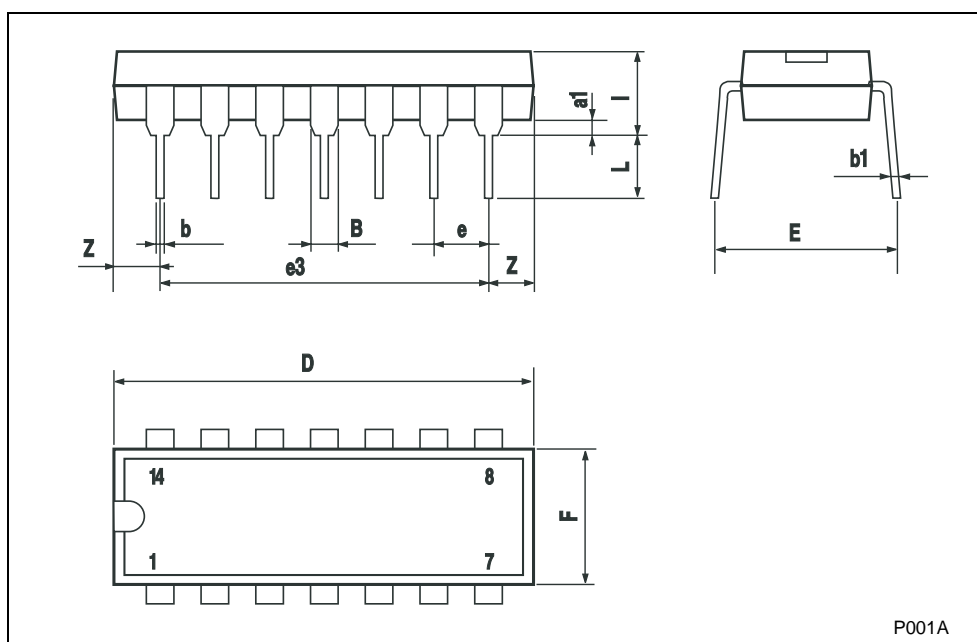

SO-14 MECHANICAL DATA

DIM.	mm.			inch		
	MIN.	TYP.	MAX.	MIN.	TYP.	MAX.
A			1.75			0.068
a1	0.1		0.2	0.003		0.007
a2			1.65			0.064
b	0.35		0.46	0.013		0.018
b1	0.19		0.25	0.007		0.010
C		0.5			0.019	
c1	45° (typ.)					
D	8.55		8.75	0.336		0.344
E	5.8		6.2	0.228		0.244
e		1.27			0.050	
e3		7.62			0.300	
F	3.8		4.0	0.149		0.157
G	4.6		5.3	0.181		0.208
L	0.5		1.27	0.019		0.050
M			0.68			0.026
S	8° (max.)					

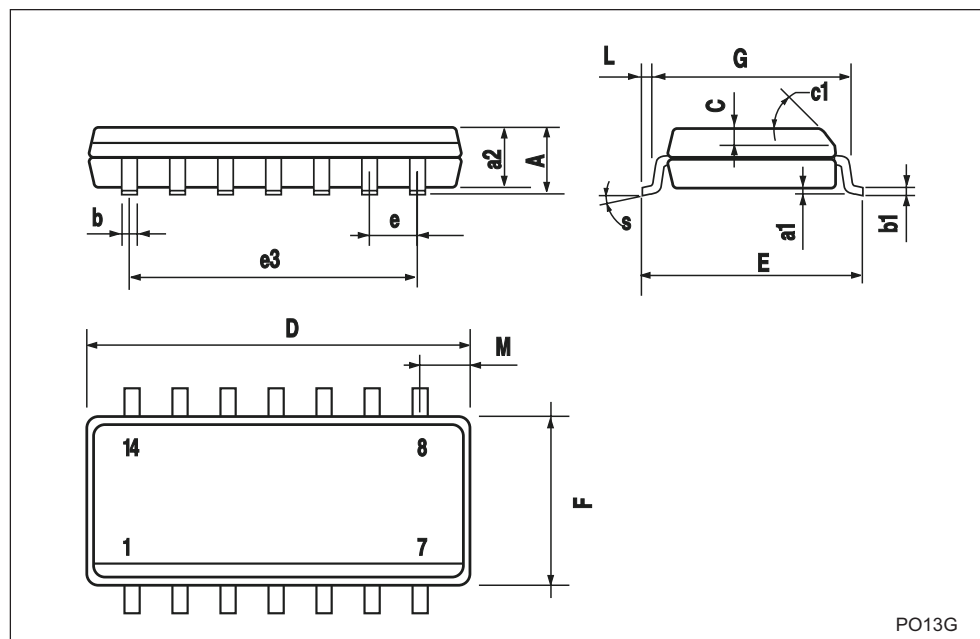

TSSOP14 MECHANICAL DATA

DIM.	mm.			inch		
	MIN.	TYP	MAX.	MIN.	TYP.	MAX.
A			1.2			0.047
A1	0.05		0.15	0.002	0.004	0.006
A2	0.8	1	1.05	0.031	0.039	0.041
b	0.19		0.30	0.007		0.012
c	0.09		0.20	0.004		0.0089
D	4.9	5	5.1	0.193	0.197	0.201
E	6.2	6.4	6.6	0.244	0.252	0.260
E1	4.3	4.4	4.48	0.169	0.173	0.176
e		0.65 BSC			0.0256 BSC	
K	0°		8°	0°		8°
L	0.45	0.60	0.75	0.018	0.024	0.030

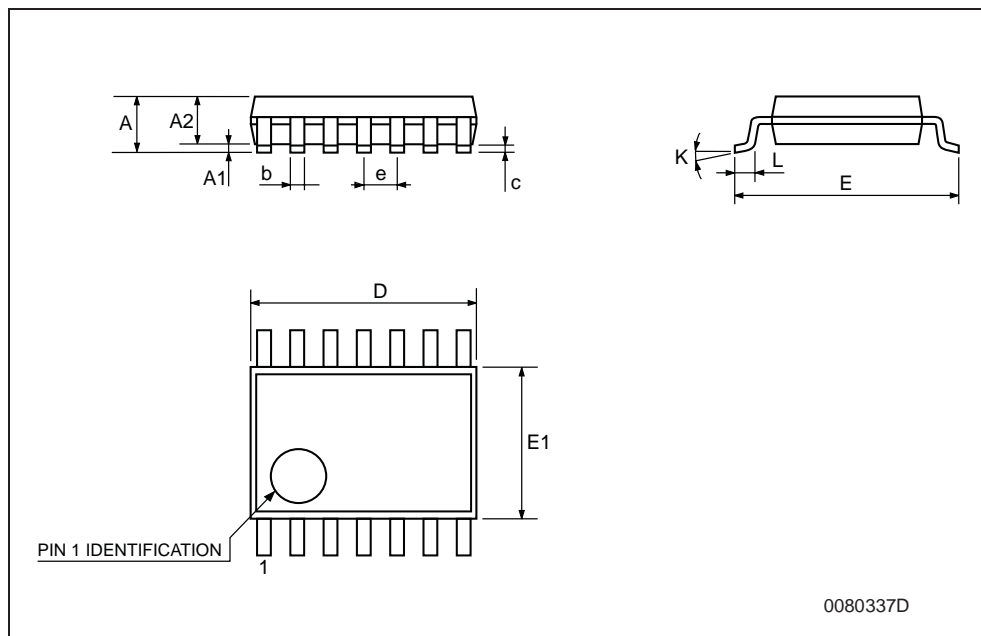

Tape & Reel SO-14 MECHANICAL DATA

DIM.	mm.			inch		
	MIN.	TYP.	MAX.	MIN.	TYP.	MAX.
A			330			12.992
C	12.8		13.2	0.504		0.519
D	20.2			0.795		
N	60			2.362		
T			22.4			0.882
Ao	6.4		6.6	0.252		0.260
Bo	9		9.2	0.354		0.362
Ko	2.1		2.3	0.082		0.090
Po	3.9		4.1	0.153		0.161
P	7.9		8.1	0.311		0.319

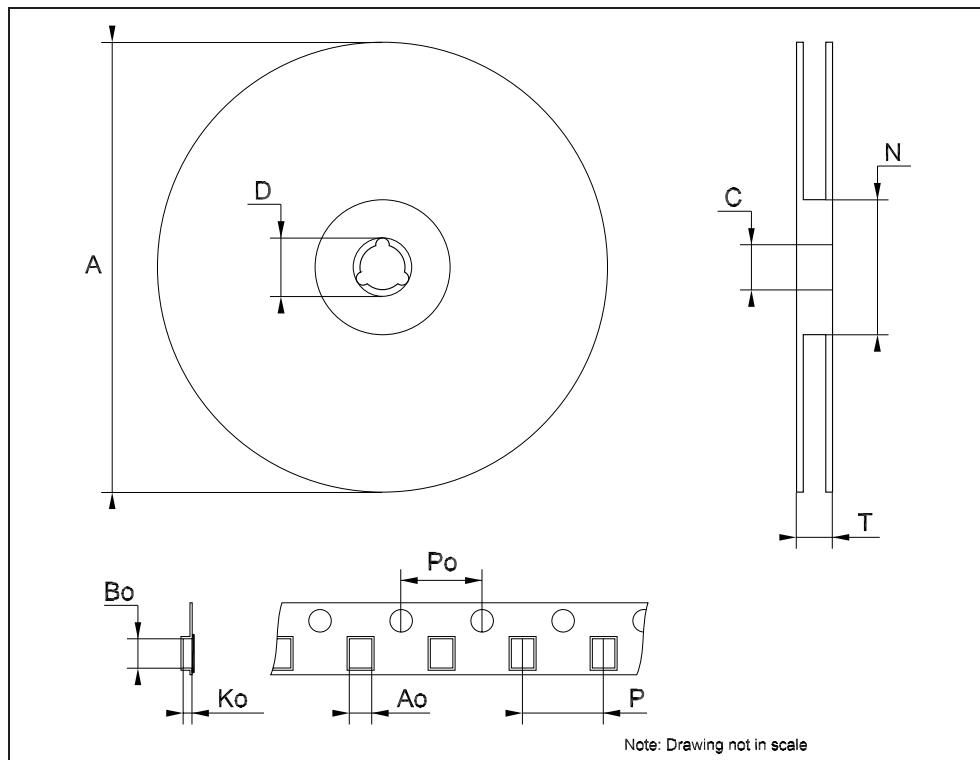

Tape & Reel TSSOP14 MECHANICAL DATA

DIM.	mm.			inch		
	MIN.	TYP.	MAX.	MIN.	TYP.	MAX.
A			330			12.992
C	12.8		13.2	0.504		0.519
D	20.2			0.795		
N	60			2.362		
T			22.4			0.882
Ao	6.7		6.9	0.264		0.272
Bo	5.3		5.5	0.209		0.217
Ko	1.6		1.8	0.063		0.071
Po	3.9		4.1	0.153		0.161
P	7.9		8.1	0.311		0.319

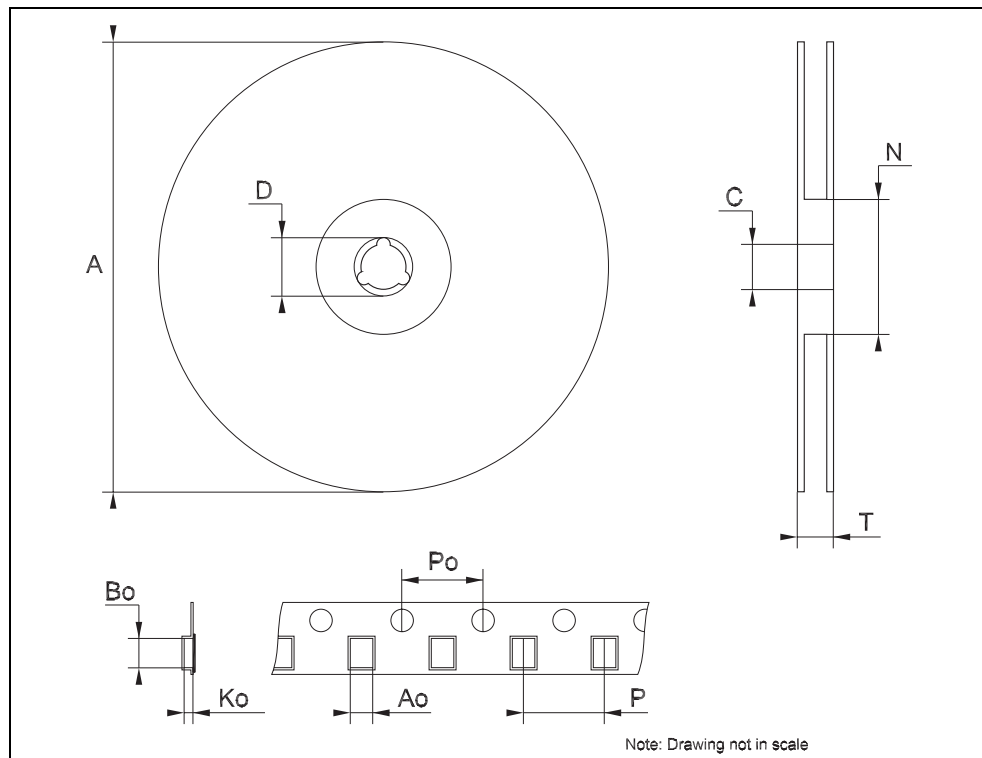

5 Revision history

Table 9. Document revision history

Date	Revision	Changes
01-Jul-2001	1	Initial release.
23-May-2008	2	Document converted and restructured to new template. Removed: M74HC14M1R order code. Added: tape and reel specifications for SO-14 and TSSOP14 packages.

Please Read Carefully:

Information in this document is provided solely in connection with ST products. STMicroelectronics NV and its subsidiaries ("ST") reserve the right to make changes, corrections, modifications or improvements, to this document, and the products and services described herein at any time, without notice.

All ST products are sold pursuant to ST's terms and conditions of sale.

Purchasers are solely responsible for the choice, selection and use of the ST products and services described herein, and ST assumes no liability whatsoever relating to the choice, selection or use of the ST products and services described herein.

No license, express or implied, by estoppel or otherwise, to any intellectual property rights is granted under this document. If any part of this document refers to any third party products or services it shall not be deemed a license grant by ST for the use of such third party products or services, or any intellectual property contained therein or considered as a warranty covering the use in any manner whatsoever of such third party products or services or any intellectual property contained therein.

UNLESS OTHERWISE SET FORTH IN ST'S TERMS AND CONDITIONS OF SALE ST DISCLAIMS ANY EXPRESS OR IMPLIED WARRANTY WITH RESPECT TO THE USE AND/OR SALE OF ST PRODUCTS INCLUDING WITHOUT LIMITATION IMPLIED WARRANTIES OF MERCHANTABILITY, FITNESS FOR A PARTICULAR PURPOSE (AND THEIR EQUIVALENTS UNDER THE LAWS OF ANY JURISDICTION), OR INFRINGEMENT OF ANY PATENT, COPYRIGHT OR OTHER INTELLECTUAL PROPERTY RIGHT.

UNLESS EXPRESSLY APPROVED IN WRITING BY AN AUTHORIZED ST REPRESENTATIVE, ST PRODUCTS ARE NOT RECOMMENDED, AUTHORIZED OR WARRANTED FOR USE IN MILITARY, AIR CRAFT, SPACE, LIFE SAVING, OR LIFE SUSTAINING APPLICATIONS, NOR IN PRODUCTS OR SYSTEMS WHERE FAILURE OR MALFUNCTION MAY RESULT IN PERSONAL INJURY, DEATH, OR SEVERE PROPERTY OR ENVIRONMENTAL DAMAGE. ST PRODUCTS WHICH ARE NOT SPECIFIED AS "AUTOMOTIVE GRADE" MAY ONLY BE USED IN AUTOMOTIVE APPLICATIONS AT USER'S OWN RISK.

Resale of ST products with provisions different from the statements and/or technical features set forth in this document shall immediately void any warranty granted by ST for the ST product or service described herein and shall not create or extend in any manner whatsoever, any liability of ST.

ST and the ST logo are trademarks or registered trademarks of ST in various countries.

Information in this document supersedes and replaces all information previously supplied.

The ST logo is a registered trademark of STMicroelectronics. All other names are the property of their respective owners.

© 2008 STMicroelectronics - All rights reserved

STMicroelectronics group of companies

Australia - Belgium - Brazil - Canada - China - Czech Republic - Finland - France - Germany - Hong Kong - India - Israel - Italy - Japan - Malaysia - Malta - Morocco - Singapore - Spain - Sweden - Switzerland - United Kingdom - United States of America

www.st.com