



M48T35 M48T35Y

256 Kbit (32Kb x8) TIMEKEEPER® SRAM

- INTEGRATED ULTRA LOW POWER SRAM, REAL TIME CLOCK, POWER-FAIL CONTROL CIRCUIT and BATTERY
- BYTEWIDE™ RAM-LIKE CLOCK ACCESS
- BCD CODED YEAR, MONTH, DAY, DATE, HOURS, MINUTES and SECONDS
- FREQUENCY TEST OUTPUT for REAL TIME CLOCK
- AUTOMATIC POWER-FAIL CHIP DESELECT and WRITE PROTECTION
- WRITE PROTECT VOLTAGES (V_{PFD} = Power-fail Deselect Voltage):
 - M48T35: $4.5V \leq V_{PFD} \leq 4.75V$
 - M48T35Y: $4.2V \leq V_{PFD} \leq 4.5V$
- SELF-CONTAINED BATTERY and CRYSTAL in the CAPHAT DIP PACKAGE
- SOIC PACKAGE PROVIDES DIRECT CONNECTION for a SNAPHAT HOUSING CONTAINING the BATTERY and CRYSTAL
- SNAPHAT® HOUSING (BATTERY and CRYSTAL) is REPLACEABLE
- PIN and FUNCTION COMPATIBLE with JEDEC STANDARD 32Kb x8 SRAMs

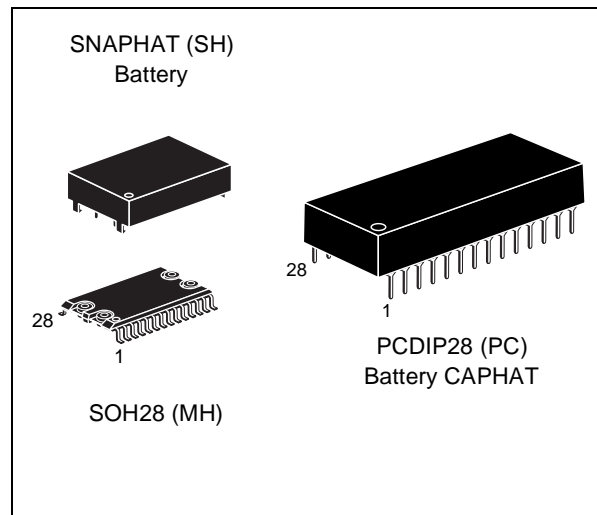

Figure 1. Logic Diagram

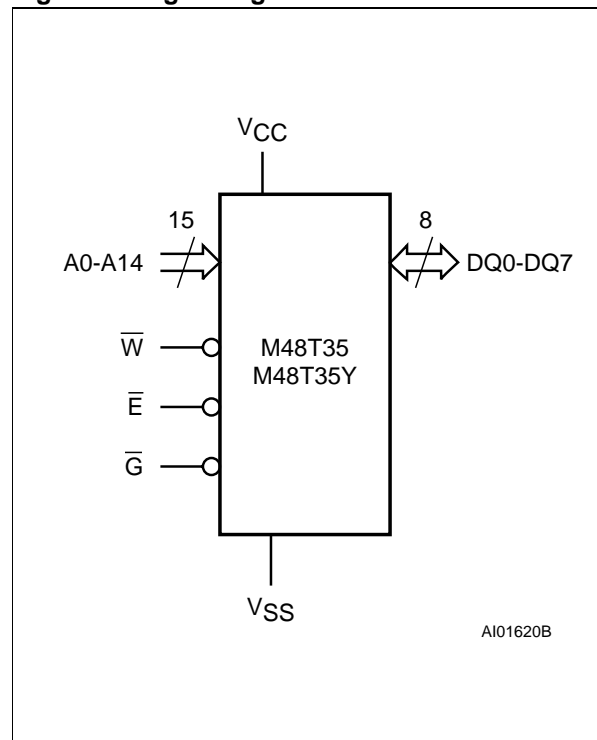

Table 1. Signal Names

A0-A14	Address Inputs
DQ0-DQ7	Data Inputs / Outputs
\bar{E}	Chip Enable
\bar{G}	Output Enable
\bar{W}	Write Enable
V_{CC}	Supply Voltage
V_{SS}	Ground

M48T35, M48T35Y

Figure 2A. DIP Connections

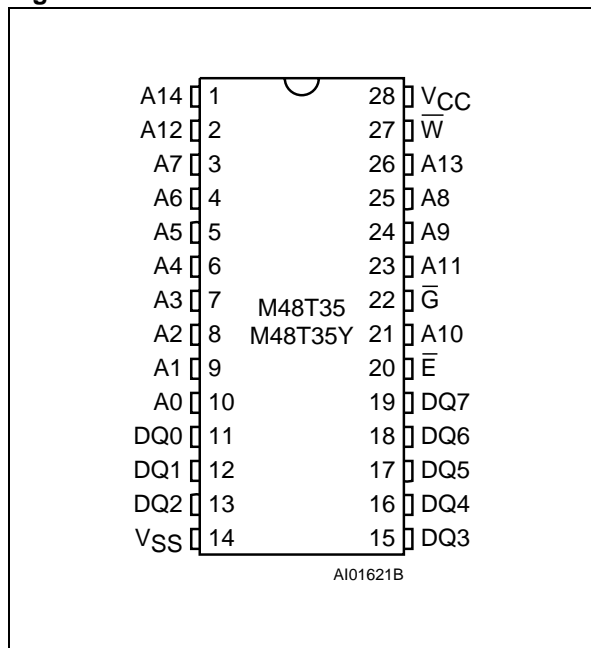

Figure 2B. SOIC Connections

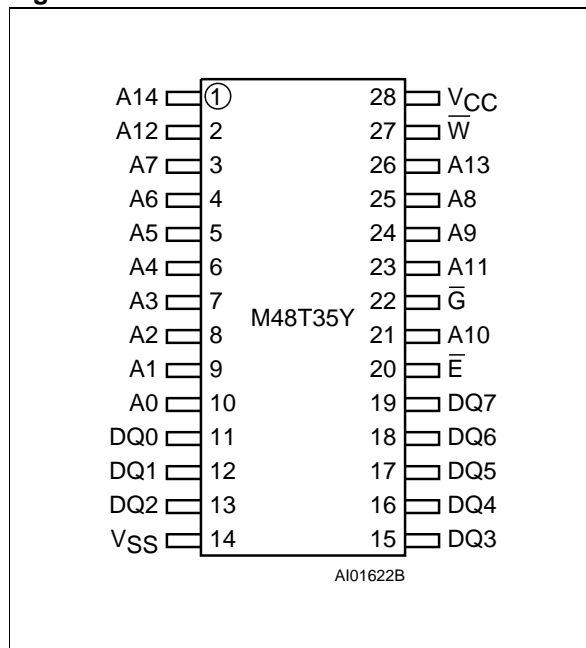

Table 2. Absolute Maximum Ratings (1)

Symbol	Parameter	Value	Unit	
T _A	Ambient Operating Temperature	Grade 1	0 to 70	°C
		Grade 6	-40 to 85	°C
T _{STG}	Storage Temperature (V _{CC} Off, Oscillator Off)	-40 to 85	°C	
T _{SLD} (2)	Lead Solder Temperature for 10 seconds	260	°C	
V _{IO}	Input or Output Voltages	-0.3 to 7	V	
V _{CC}	Supply Voltage	-0.3 to 7	V	
I _O	Output Current	20	mA	
P _D	Power Dissipation	1	W	

Note: 1. Stresses greater than those listed under "Absolute Maximum Ratings" may cause permanent damage to the device. This is a stress rating only and functional operation of the device at these or any other conditions above those indicated in the operational section of this specification is not implied. Exposure to the absolute maximum rating conditions for extended periods of time may affect reliability.

2. Soldering temperature not to exceed 260°C for 10 seconds (total thermal budget not to exceed 150°C for longer than 30 seconds).

CAUTION: Negative undershoots below -0.3V are not allowed on any pin while in the Battery Back-up mode.

CAUTION: Do NOT wave solder SOIC to avoid damaging SNAPHAT sockets.

DESCRIPTION

The M48T35/35Y TIMEKEEPER® RAM is a 32Kb x8 non-volatile static RAM and real time clock. The monolithic chip is available in two special packages to provide a highly integrated battery backed-up memory and real time clock solution.

The M48T35/35Y is a non-volatile pin and function equivalent to any JEDEC standard 32Kb x8 SRAM. It also easily fits into many ROM, EPROM,

and EEPROM sockets, providing the non-volatility of PROMs without any requirement for special write timing or limitations on the number of writes that can be performed.

The 28 pin 600mil DIP CAPHAT houses the M48T35/35Y silicon with a quartz crystal and a long life lithium button cell in a single package.

The 28 pin 330mil SOIC provides sockets with gold plated contacts at both ends for direct con-

Table 4. AC Measurement Conditions

Input Rise and Fall Times	≤ 5ns
Input Pulse Voltages	0 to 3V
Input and Output Timing Ref. Voltages	1.5V

Note that Output Hi-Z is defined as the point where data is no longer driven.

The clock locations contain the year, month, date, day, hour, minute, and second in 24 hour BCD format. Corrections for 28, 29 (leap year), 30, and 31 day months are made automatically. Byte 7FF8h is the clock control register. This byte controls user access to the clock information and also stores the clock calibration setting.

The eight clock bytes are not the actual clock counters themselves; they are memory locations consisting of BiPORT read/write memory cells. The M48T35/35Y includes a clock control circuit which updates the clock bytes with current information once per second. The information can be accessed by the user in the same manner as any other location in the static memory array.

The M48T35/35Y also has its own Power-fail Detect circuit. The control circuitry constantly monitors the single 5V supply for an out of tolerance condition. When V_{CC} is out of tolerance, the circuit write protects the SRAM, providing a high degree of data security in the midst of unpredictable system operation brought on by low V_{CC}. As V_{CC} falls below approximately 3V, the control circuitry connects the battery which maintains data and clock operation until valid power returns.

READ MODE

The M48T35/35Y is in the Read Mode whenever \overline{W} (Write Enable) is high and \overline{E} (Chip Enable) is low. The unique address specified by the 15 Address Inputs defines which one of the 32,768 bytes of data is to be accessed. Valid data will be available at the Data I/O pins within Address Access time (t_{AVQV}) after the last address input signal is stable, providing that the \overline{E} and \overline{G} access times are also satisfied.

If the \overline{E} and \overline{G} access times are not met, valid data will be available after the latter of the Chip Enable

Figure 4. AC Testing Load Circuit

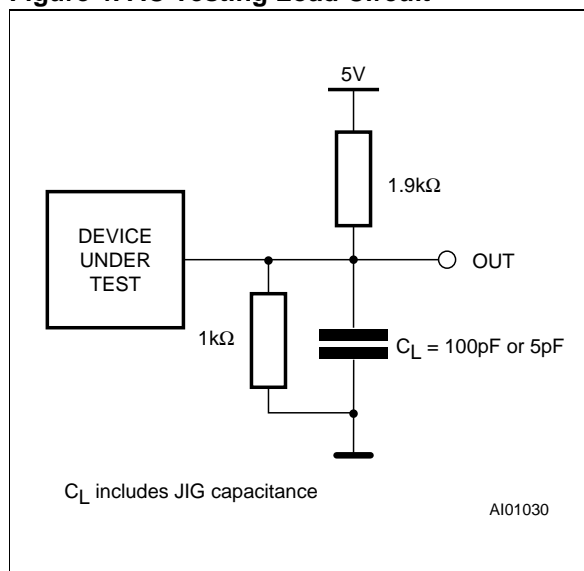

Access time (t_{ELQV}) or Output Enable Access time (t_{GLQV}).

The state of the eight three-state Data I/O signals is controlled by \overline{E} and \overline{G} . If the outputs are activated before t_{AVQV}, the data lines will be driven to an indeterminate state until t_{AVQV}.

If the Address Inputs are changed while \overline{E} and \overline{G} remain active, output data will remain valid for Output Data Hold time (t_{AXQX}) but will go indeterminate until the next Address Access.

WRITE MODE

The M48T35/35Y is in the Write Mode whenever W and E are low. The start of a write is referenced from the latter occurring falling edge of \overline{W} or \overline{E} . A write is terminated by the earlier rising edge of \overline{W} or \overline{E} . The addresses must be held valid throughout the cycle. \overline{E} or \overline{W} must return high for a minimum of t_{EHAX} from Chip Enable or t_{WHAX} from Write Enable prior to the initiation of another read or write cycle. Data-in must be valid t_{DVWH} prior to the end of write and remain valid for t_{WHDX} afterward. \overline{G} should be kept high during write cycles to avoid bus contention; although, if the output bus has been activated by a low on \overline{E} and \overline{G} , a low on W will disable the outputs t_{WLQZ} after \overline{W} falls.

Table 5. Capacitance (1, 2)
($T_A = 25\text{ }^\circ\text{C}$)

Symbol	Parameter	Test Condition	Min	Max	Unit
C_{IN}	Input Capacitance	$V_{IN} = 0V$		10	pF
$C_{IO}^{(3)}$	Input / Output Capacitance	$V_{OUT} = 0V$		10	pF

Note: 1. Effective capacitance measured with power supply at 5V.
2. Sampled only, not 100% tested.
3. Outputs deselected.

Table 6. DC Characteristics
($T_A = 0$ to $70\text{ }^\circ\text{C}$ or -40 to $85\text{ }^\circ\text{C}$; $V_{CC} = 4.75V$ to $5.5V$ or $4.5V$ to $5.5V$)

Symbol	Parameter	Test Condition	Min	Max	Unit
$I_{LI}^{(1)}$	Input Leakage Current	$0V \leq V_{IN} \leq V_{CC}$		± 1	μA
$I_{LO}^{(1)}$	Output Leakage Current	$0V \leq V_{OUT} \leq V_{CC}$		± 5	μA
I_{CC}	Supply Current	Outputs open		50	mA
I_{CC1}	Supply Current (Standby) TTL	$\bar{E} = V_{IH}$		3	mA
I_{CC2}	Supply Current (Standby) CMOS	$\bar{E} = V_{CC} - 0.2V$		3	mA
$V_{IL}^{(2)}$	Input Low Voltage		-0.3	0.8	V
V_{IH}	Input High Voltage		2.2	$V_{CC} + 0.3$	V
V_{OL}	Output Low Voltage	$I_{OL} = 2.1mA$		0.4	V
V_{OH}	Output High Voltage	$I_{OH} = -1mA$	2.4		V

Note: 1. Outputs deselected.
2. Negative spikes of -1V allowed for up to 10ns once per cycle.

Table 7. Power Down/Up Trip Points DC Characteristics (1)
($T_A = 0$ to $70\text{ }^\circ\text{C}$ or -40 to $85\text{ }^\circ\text{C}$)

Symbol	Parameter		Min	Typ	Max	Unit
V_{PFD}	Power-fail Deselect Voltage	M48T35	4.5	4.6	4.75	V
		M48T35Y	4.2	4.35	4.5	V
V_{SO}	Battery Back-up Switchover Voltage			3.0		V
t_{DR}	Expected Data Retention Time (at 25°C)	Grade 1	$10^{(2)}$			YEARS
		Grade 6	$10^{(3)}$			YEARS

Note: 1. All voltages referenced to V_{SS} .
2. CAPHAT and M4T32-BR12SH1 SNAPHAT only, M4T28-BR12SH1 SNAPHAT top $t_{DR} = 7$ years (typ).
3. Using larger M4T32-BR12SH6 SNAPHAT top (recommended for Industrial Temperature Range - grade 6 device).

M48T35, M48T35Y

Table 8. Power Down/Up AC Characteristics

($T_A = 0$ to 70 °C or -40 to 85 °C)

Symbol	Parameter	Min	Max	Unit
t_{PD}	\bar{E} or \bar{W} at V_{IH} before Power Down	0		μs
$t_F^{(1)}$	$V_{PFD}(\max)$ to $V_{PFD}(\min)$ V_{CC} Fall Time	300		μs
$t_{FB}^{(2)}$	$V_{PFD}(\min)$ to V_{SS} V_{CC} Fall Time	10		μs
t_R	$V_{PFD}(\min)$ to $V_{PFD}(\max)$ V_{CC} Rise Time	10		μs
t_{RB}	V_{SS} to $V_{PFD}(\min)$ V_{CC} Rise Time	1		μs
$t_{REC}^{(3)}$	$V_{PFD}(\max)$ to Inputs Recognized	40	200	ms

Note: 1. $V_{PFD}(\max)$ to $V_{PFD}(\min)$ fall time of less than t_F may result in deselection/write protection not occurring until $200\mu s$ after V_{CC} passes $V_{PFD}(\min)$.

2. $V_{PFD}(\min)$ to V_{SS} fall time of less than t_{FB} may cause corruption of RAM data.

3. $t_{REC}(\min) = 20ms$ for industrial temperature grade (6) device.

Figure 5. Power Down/Up Mode AC Waveforms

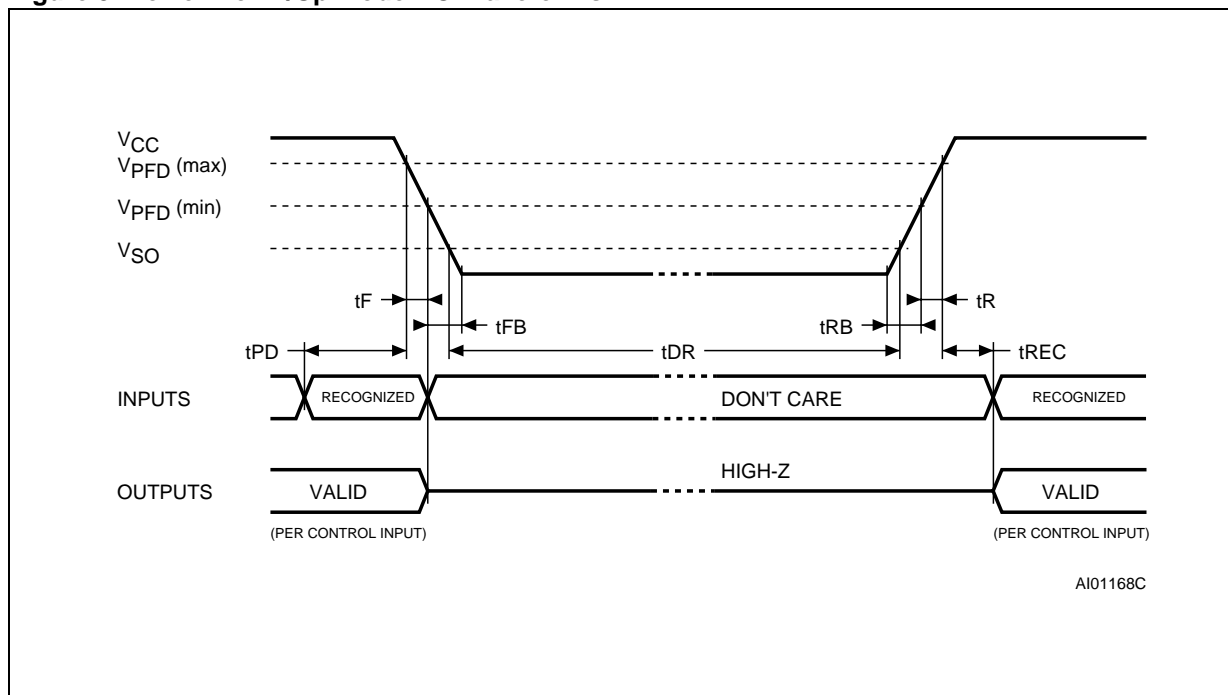
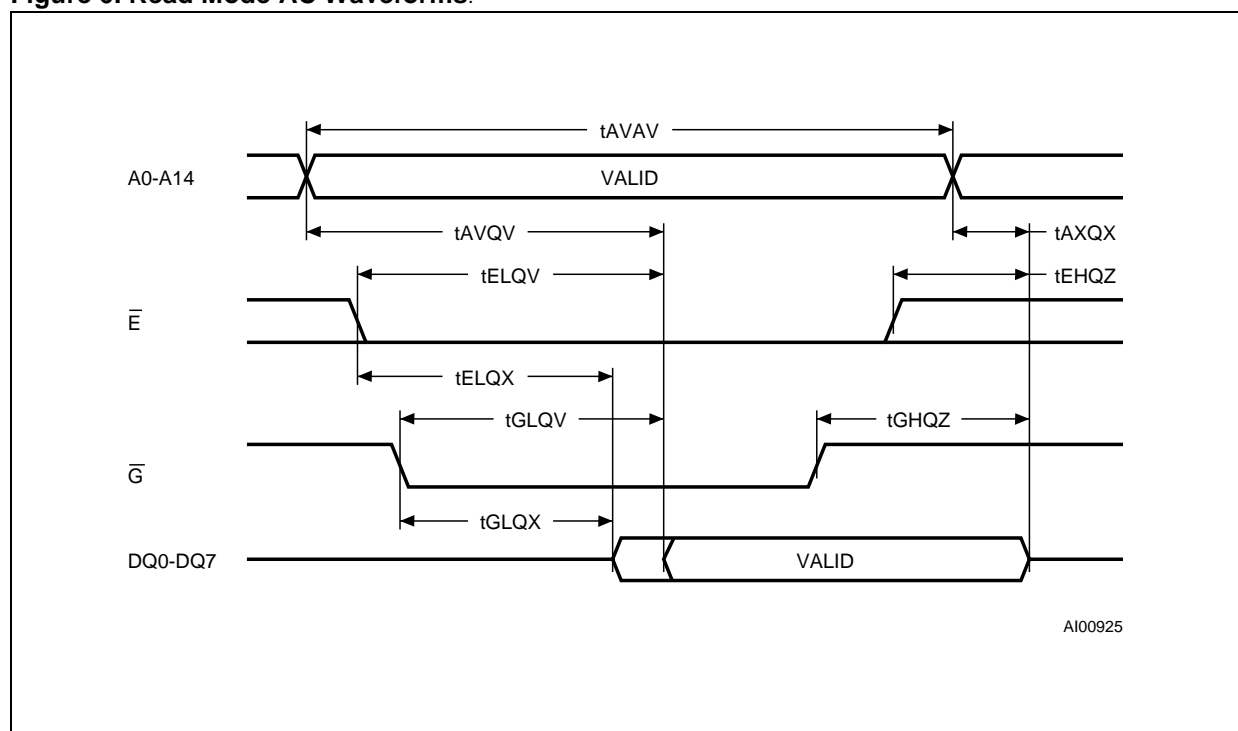

Table 9. Read Mode AC Characteristics(T_A = 0 to 70 °C or -40 to 85 °C; V_{CC} = 4.75V to 5.5V or 4.5V to 5.5V)

Symbol	Parameter	M48T35 / M48T35Y		Unit
		-70		
		Min	Max	
t _{AVAV}	Read Cycle Time	70		ns
t _{AVQV} ⁽¹⁾	Address Valid to Output Valid		70	ns
t _{ELQV} ⁽¹⁾	Chip Enable Low to Output Valid		70	ns
t _{GLQV} ⁽¹⁾	Output Enable Low to Output Valid		35	ns
t _{ELQX} ⁽²⁾	Chip Enable Low to Output Transition	5		ns
t _{GLQX} ⁽²⁾	Output Enable Low to Output Transition	5		ns
t _{EHQZ} ⁽²⁾	Chip Enable High to Output Hi-Z		25	ns
t _{GHQZ} ⁽²⁾	Output Enable High to Output Hi-Z		25	ns
t _{AXQX} ⁽¹⁾	Address Transition to Output Transition	10		ns

Note: 1. C_L = 100pF.
2. C_L = 5pF.

Figure 6. Read Mode AC Waveforms.

Note: Write Enable (\bar{W}) = High.

M48T35, M48T35Y

Table 10. Write Mode AC Characteristics

($T_A = 0$ to 70 °C or -40 to 85 °C; $V_{CC} = 4.75V$ to $5.5V$ or $4.5V$ to $5.5V$)

Symbol	Parameter	M48T35 / M48T35Y		Unit
		-70		
		Min	Max	
t_{AVAV}	Write Cycle Time	70		ns
t_{AVWL}	Address Valid to Write Enable Low	0		ns
t_{AVEL}	Address Valid to Chip Enable Low	0		ns
t_{WLWH}	Write Enable Pulse Width	50		ns
t_{ELEH}	Chip Enable Low to Chip Enable High	55		ns
t_{WHAX}	Write Enable High to Address Transition	0		ns
t_{EHAX}	Chip Enable High to Address Transition	0		ns
t_{DVWH}	Input Valid to Write Enable High	30		ns
t_{DVEH}	Input Valid to Chip Enable High	30		ns
t_{WHDX}	Write Enable High to Input Transition	5		ns
t_{EHDX}	Chip Enable High to Input Transition	5		ns
$t_{WLQZ}^{(1, 2)}$	Write Enable Low to Output Hi-Z		25	ns
t_{AVWH}	Address Valid to Write Enable High	60		ns
t_{AVEH}	Address Valid to Chip Enable High	60		ns
$t_{WHQX}^{(1, 2)}$	Write Enable High to Output Transition	5		ns

Note: 1. $C_L = 5pF$.

2. If \bar{E} goes low simultaneously with \bar{W} going low, the outputs remain in the high impedance state.

DATA RETENTION MODE

With valid V_{CC} applied, the M48T35/35Y operates as a conventional BYTEWIDE static RAM. Should the supply voltage decay, the RAM will automatically power-fail deselect, write protecting itself when V_{CC} falls within the V_{PFD} (max), V_{PFD} (min) window. All outputs become high impedance, and all inputs are treated as "don't care."

Note: A power failure during a write cycle may corrupt data at the currently addressed location, but does not jeopardize the rest of the RAM's content. At voltages below V_{PFD} (min), the user can be assured the memory will be in a write protected state, provided the V_{CC} fall time is not less than t_F . The M48T35/35Y may respond to transient noise spikes on V_{CC} that reach into the deselect window during the time the device is sampling V_{CC} . Therefore, decoupling of the power supply lines is recommended.

When V_{CC} drops below V_{SO} , the control circuit switches power to the internal battery which preserves data and powers the clock. The internal button cell will maintain data in the M48T35/35Y for an accumulated period of at least 7 years when V_{CC} is less than V_{SO} . As system power returns and V_{CC} rises above V_{SO} , the battery is disconnected, and the power supply is switched to external V_{CC} . Write protection continues until V_{CC} reaches V_{PFD} (min) plus t_{REC} (min). \bar{E} should be kept high as V_{CC} rises past V_{PFD} (min) to prevent inadvertent write cycles prior to processor stabilization. Normal RAM operation can resume t_{REC} after V_{CC} exceeds V_{PFD} (max).

For more information on Battery Storage Life refer to the Application Note AN1012.

Figure 7. Write Enable Controlled, Write AC Waveform

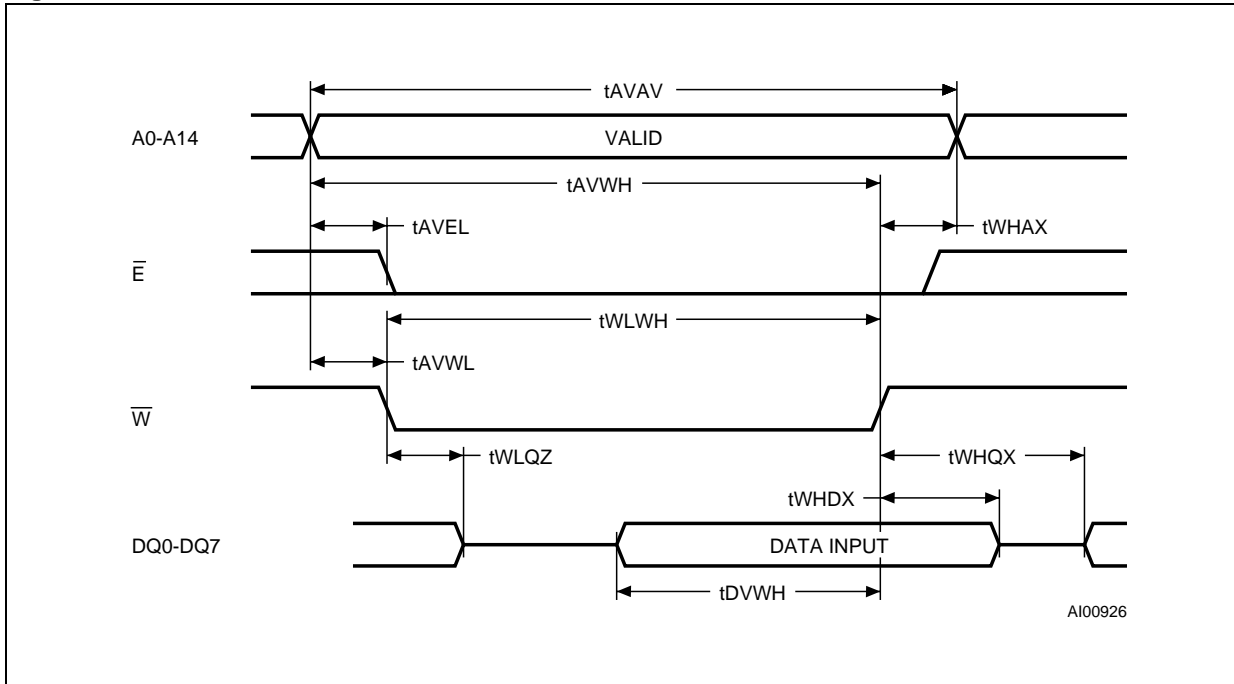

Figure 8. Chip Enable Controlled, Write AC Waveforms

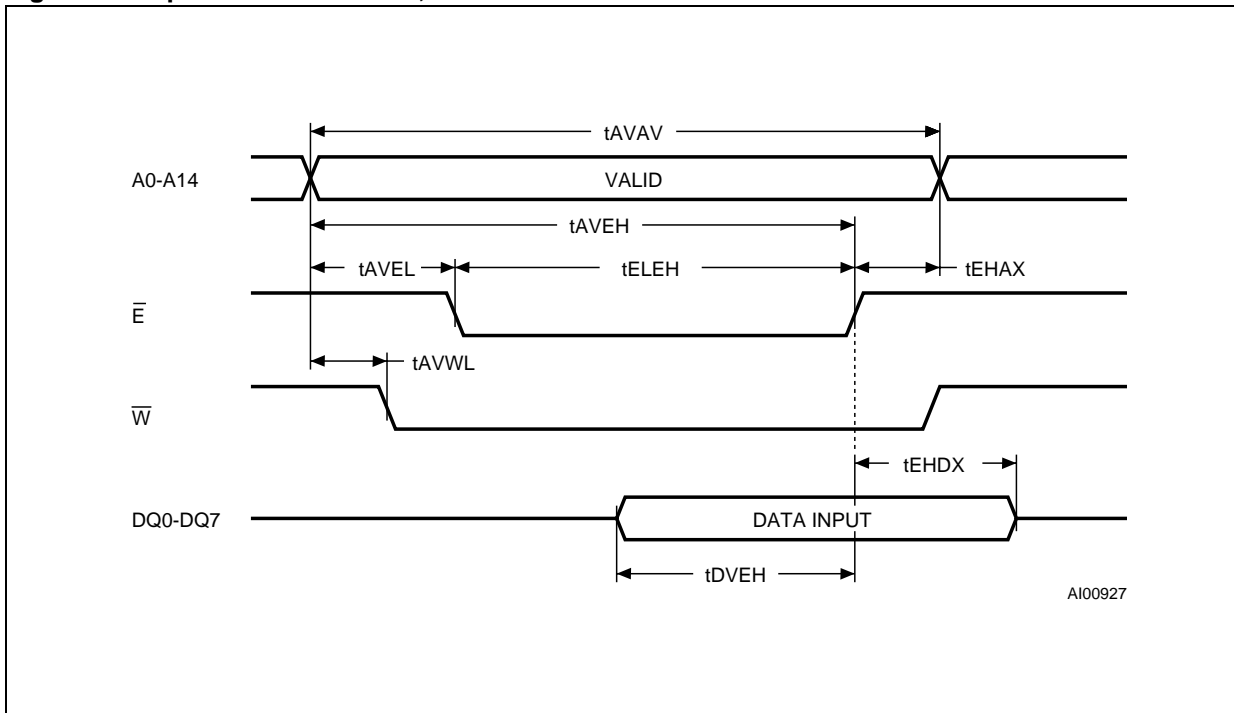

Table 11. Register Map

Address	Data								Function/Range BCD Format	
	D7	D6	D5	D4	D3	D2	D1	D0		
7FFFh	10 Years				Year				Year	00-99
7FFEh	0	0	0	10 M	Month				Month	01-12
7FFDh	0	0	10 Date		Date: Day of Month				Date	01-31
7FFCh	0	FT	CEB	CB	0	Day of Week			Century/Day	00-01/01-07
7FFBh	0	0	10 Hours		Hours (24 Hour Format)				Hour	00-23
7FFAh	0	10 Minutes			Minutes				Minutes	00-59
7FF9h	ST	10 Seconds			Seconds				Seconds	00-59
7FF8h	W	R	S	Calibration				Control		

Keys: S = Sign Bit
 FT = Frequency Test Bit (Must be set to '0' upon power for normal operation)
 R = Read Bit
 W = Write Bit
 ST = Stop Bit
 0 = Must be set to zero
 CEB = Century Enable Bit
 CB = Century Bit

Note: When CEB is set to '1', CB will toggle from '0' to '1' or from '1' to '0' at the turn of the century (dependent upon the initial value set).
 When CEB is set to '0', CB will not toggle.
 The WRITE Bit does not need to be set to write to CEB and CB.

CLOCK OPERATIONS

Reading the Clock Updates to the TIMEKEEPER registers should be halted before clock data is read to prevent reading data in transition. Because the BiPORT TIMEKEEPER cells in the RAM array are only data registers, and not the actual clock counters, updating the registers can be halted without disturbing the clock itself.

Updating is halted when a '1' is written to the READ bit, D6 in the Control Register 7FF8h. As long as a '1' remains in that position, updating is halted. After a halt is issued, the registers reflect the count; that is, the day, date, and the time that were current at the moment the halt command was issued.

All of the TIMEKEEPER registers are updated simultaneously. A halt will not interrupt an update in progress. Updating is within a second after the bit is reset to a '0'.

Setting the Clock

Bit D7 of the Control Register 7FF8h is the WRITE bit. Setting the WRITE bit to a '1', like the READ bit, halts updates to the TIMEKEEPER registers. The user can then load them with the correct day, date, and time data in 24 hour BCD format (see Table 11). Resetting the WRITE bit to a '0' then transfers the values of all time registers 7FF9h-7FFFh to the actual TIMEKEEPER counters and

allows normal operation to resume. The FT bit and the bits marked as '0' in Table 11 must be written to '0' to allow for normal TIMEKEEPER and RAM operation. After the WRITE bit is reset, the next clock update will occur within one second.

See the Application Note AN923 "TIMEKEEPER rolling into the 21st century" on the for information on Century Rollover.

Stopping and Starting the Oscillator

The oscillator may be stopped at any time. If the device is going to spend a significant amount of time on the shelf, the oscillator can be turned off to minimize current drain on the battery. The STOP bit is the MSB of the seconds register. Setting it to a '1' stops the oscillator. The M48T35/35Y is shipped from STMicroelectronics with the STOP bit set to a '1'. When reset to a '0', the M48T35/35Y oscillator starts within 1 second.

Calibrating the Clock

The M48T35/35Y is driven by a quartz controlled oscillator with a nominal frequency of 32,768 Hz. The devices are tested not to exceed 35 ppm (parts per million) oscillator frequency error at 25 °C, which equates to about ±1.53 minutes per month. With the calibration bits properly set, the accuracy of each M48T35/35Y improves to better than ±4 ppm at 25 °C. The oscillation rate of any crystal changes with temperature (see Figure 10).



Figure 9. Clock Calibration

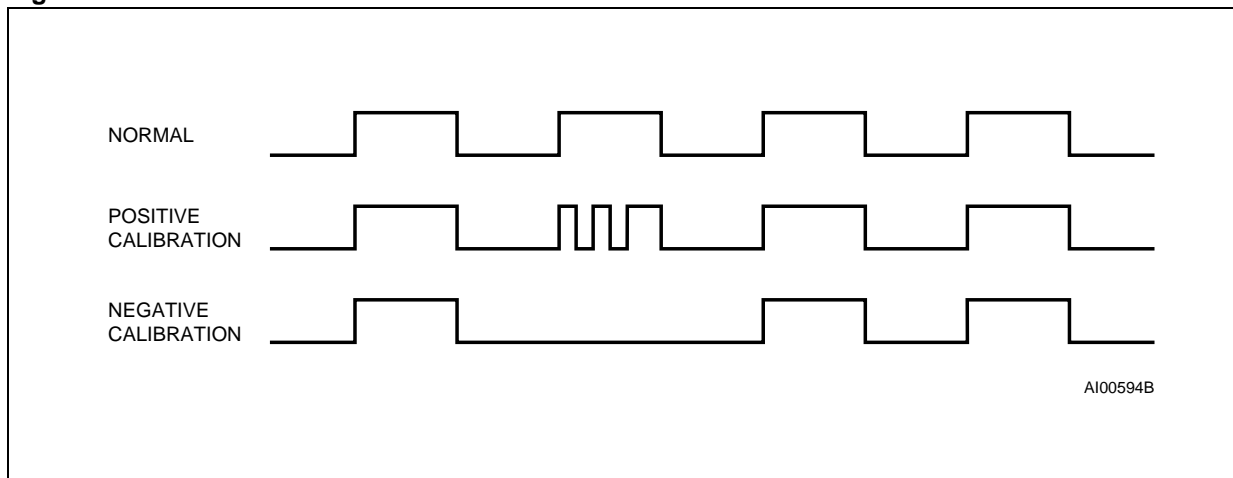

Most clock chips compensate for crystal frequency and temperature shift error with cumbersome trim capacitors. The M48T35/35Y design, however, employs periodic counter correction. The calibration circuit adds or subtracts counts from the oscillator divider circuit at the divide by 256 stage, as shown in Figure 9. The number of times pulses are blanked (subtracted, negative calibration) or split (added, positive calibration) depends upon the value loaded into the five Calibration bits found in the Control Register. Adding counts speeds the clock up, subtracting counts slows the clock down.

The Calibration byte occupies the five lower order bits (D4-D0) in the Control Register 7FF8h. These bits can be set to represent any value between 0 and 31 in binary form. Bit D5 is a Sign bit; '1' indicates positive calibration, '0' indicates negative calibration. Calibration occurs within a 64 minute cycle. The first 62 minutes in the cycle may, once per minute, have one second either shortened by 128 or lengthened by 256 oscillator cycles. If a binary '1' is loaded into the register, only the first 2 minutes in the 64 minute cycle will be modified; if a binary 6 is loaded, the first 12 will be affected, and so on.

Therefore, each calibration step has the effect of adding 512 or subtracting 256 oscillator cycles for every 125,829,120 actual oscillator cycles, that is +4.068 or -2.034 ppm of adjustment per calibration step in the calibration register. Assuming that the oscillator is in fact running at exactly 32,768 Hz, each of the 31 increments in the Calibration byte would represent +10.7 or -5.35 seconds per month which corresponds to a total range of +5.5 or -2.75 minutes per month.

Two methods are available for ascertaining how much calibration a given M48T35/35Y may require. The first involves simply setting the clock, letting it run for a month and comparing it to a known accurate reference (like WWV broadcasts). While that may seem crude, it allows the designer to give the end user the ability to calibrate his clock as his environment may require, even after the final product is packaged in a non-user serviceable enclosure.

All the designer has to do is provide a simple utility that accesses the Calibration byte.

The second approach is better suited to a manufacturing environment, and involves the use of some test equipment. When the Frequency Test (FT) bit, the seventh-most significant bit in the Day Register is set to a '1', and D7 of the Seconds Register is a '0' (Oscillator Running), DQ0 will toggle at 512Hz during a read of the Seconds Register. Any deviation from 512 Hz indicates the degree and direction of oscillator frequency shift at the test temperature. For example, a reading of 512.01024 Hz would indicate a +20 ppm oscillator frequency error, requiring a -10 (WR001010) to be loaded into the Calibration Byte for correction. Note that setting or changing the Calibration Byte does not affect the Frequency test output frequency.

The FT bit MUST be reset to '0' for normal clock operations to resume. The FT bit is automatically Reset on power-up.

For more information on calibration, see the Application Note AN934 "TIMEKEEPER Calibration".

Figure 10. Crystal Accuracy Across Temperature

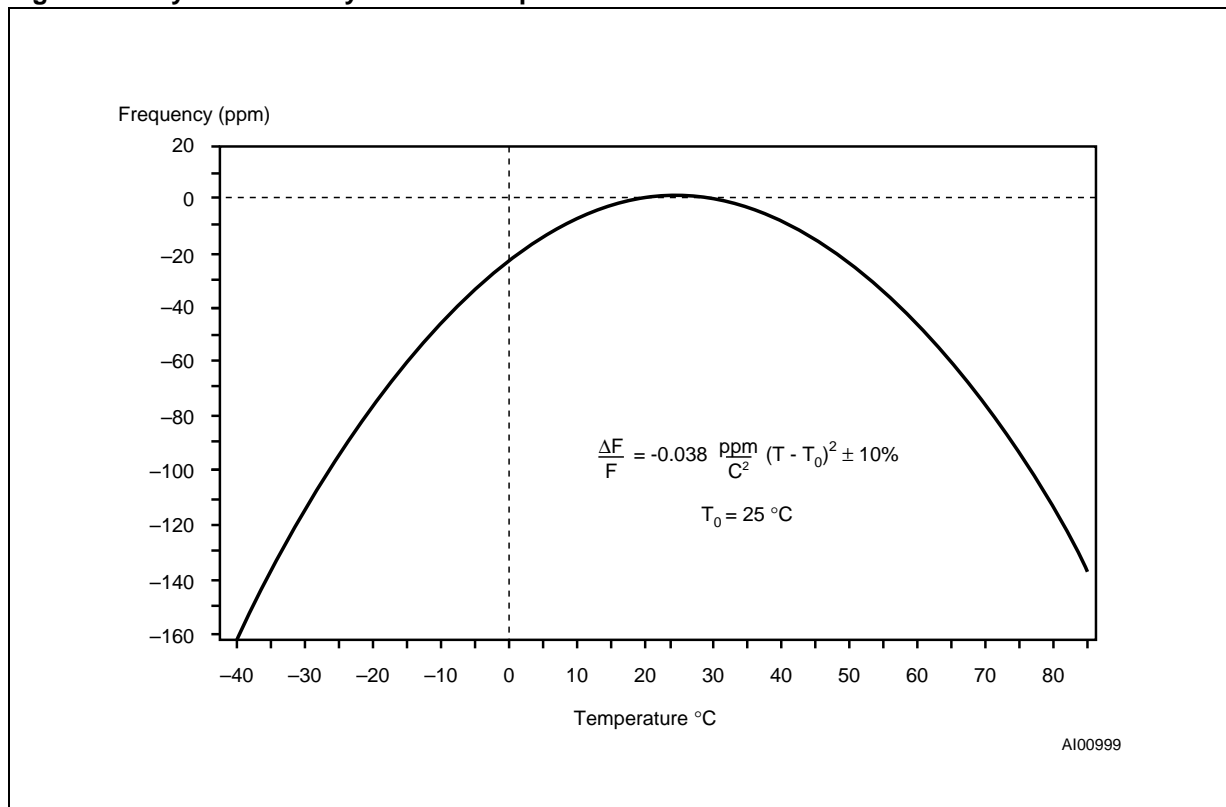

POWER SUPPLY DECOUPLING and UNDERSHOOT PROTECTION

V_{CC} transients, including those produced by output switching, can produce voltage fluctuations, resulting in spikes on the V_{CC} bus. These transients can be reduced if capacitors are used to store energy, which stabilizes the V_{CC} bus. The energy stored in the bypass capacitors will be released as low going spikes are generated or energy will be absorbed when overshoots occur. A bypass capacitor value of $0.1\mu\text{F}$ (as shown in Figure 11) is recommended in order to provide the needed filtering.

In addition to transients that are caused by normal SRAM operation, power cycling can generate negative voltage spikes on V_{CC} that drive it to values below V_{SS} by as much as one Volt. These negative spikes can cause data corruption in the SRAM while in battery backup mode. To protect from these voltage spikes, it is recommended to connect a schottky diode from V_{CC} to V_{SS} (cathode connected to V_{CC} , anode to V_{SS}). Schottky diode 1N5817 is recommended for through hole and MBRS120T3 is recommended for surface mount.

Figure 11. Supply Voltage Protection

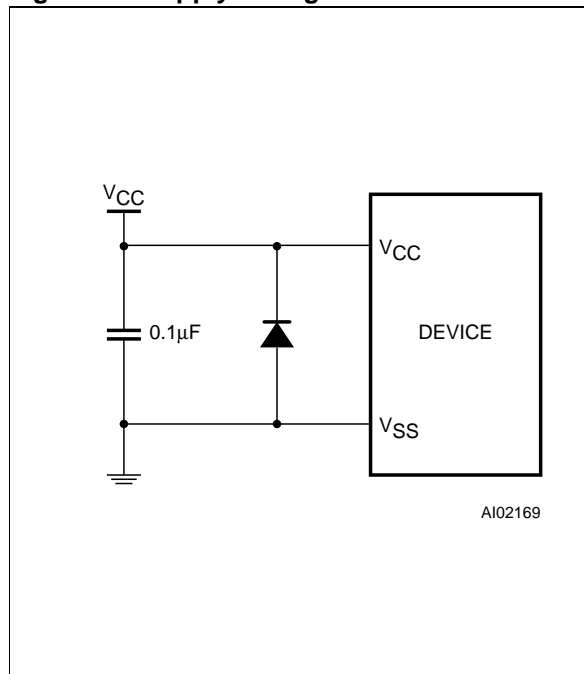
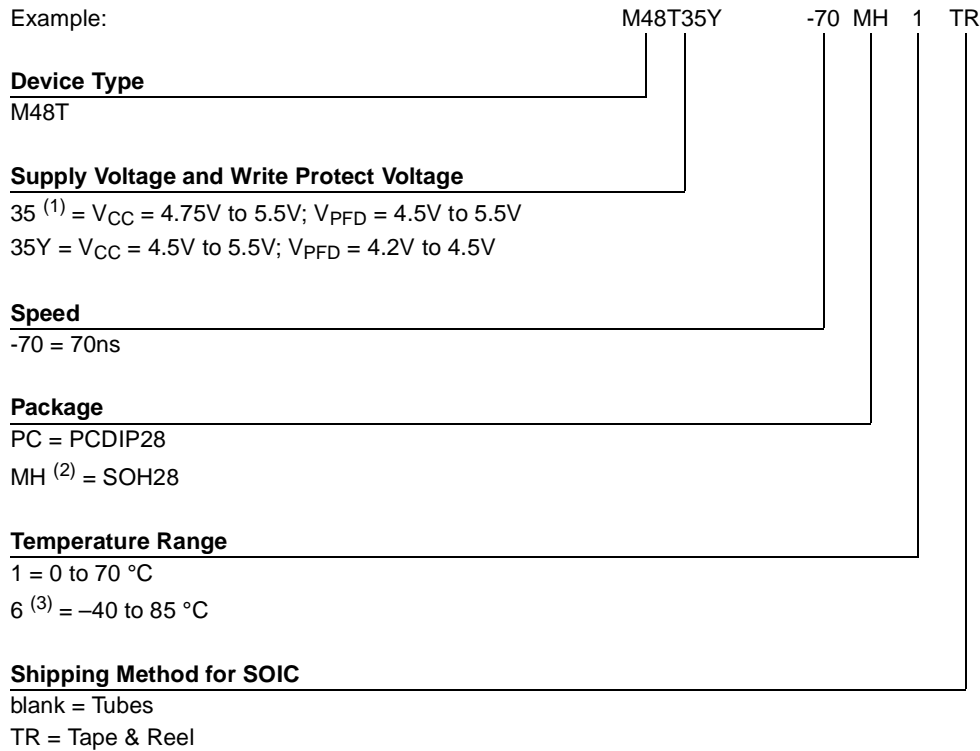

Table 12. Ordering Information Scheme



Note: 1. The M48T35 part is offered with the PCDIP28 (i.e. CAPHAT) package only.
 2. The SOIC package (SOH28) requires the battery package (SNAPHAT) which is ordered separately under the part number "M4TXX-BR12SH1" in plastic tube or "M4TXX-BR12SH1TR" in Tape & Reel form.
 3. Available in SOIC package only.
Caution: Do not place the SNAPHAT battery package "M4TXX-BR12SH1" in conductive foam since will drain the lithium button-cell battery.

For a list of available options (Speed, Package, etc...) or for further information on any aspect of this device, please contact the ST Sales Office nearest to you.

Table 13. Revision History

Date	Revision Details
November 1999	First Issue
02/07/00	t _{DR} Description changed (Table 7)

M48T35, M48T35Y

Table 14. PCDIP28 - 28 pin Plastic DIP, battery CAPHAT, Package Mechanical Data

Symb	mm			inches		
	Typ	Min	Max	Typ	Min	Max
A		8.89	9.65		0.350	0.380
A1		0.38	0.76		0.015	0.030
A2		8.38	8.89		0.330	0.350
B		0.38	0.53		0.015	0.021
B1		1.14	1.78		0.045	0.070
C		0.20	0.31		0.008	0.012
D		39.37	39.88		1.550	1.570
E		17.83	18.34		0.702	0.722
e1		2.29	2.79		0.090	0.110
e3		29.72	36.32		1.170	1.430
eA		15.24	16.00		0.600	0.630
L		3.05	3.81		0.120	0.150
N		28			28	

Figure 12. PCDIP28 - 28 pin Plastic DIP, battery CAPHAT, Package Outline

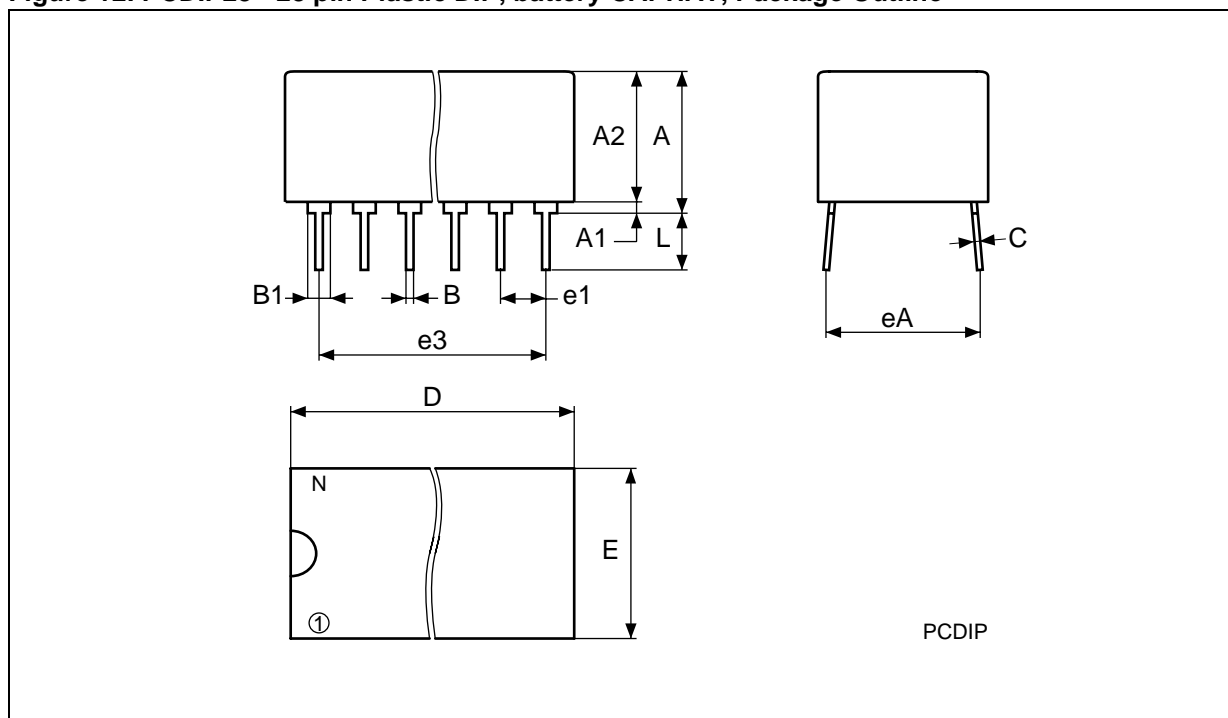

Drawing is not to scale.

Table 15. SOH28 - 28 lead Plastic Small Outline, 4-socket battery SNAPHAT, Package Mechanical Data

Symb	mm			inches		
	Typ	Min	Max	Typ	Min	Max
A			3.05			0.120
A1		0.05	0.36		0.002	0.014
A2		2.34	2.69		0.092	0.106
B		0.36	0.51		0.014	0.020
C		0.15	0.32		0.006	0.012
D		17.71	18.49		0.697	0.728
E		8.23	8.89		0.324	0.350
e	1.27	–	–	0.050	–	–
eB		3.20	3.61		0.126	0.142
H		11.51	12.70		0.453	0.500
L		0.41	1.27		0.016	0.050
α		0°	8°		0°	8°
N	28			28		
CP			0.10			0.004

Figure 13. SOH28 - 28 lead Plastic Small Outline, 4-socket battery SNAPHAT, Package Outline

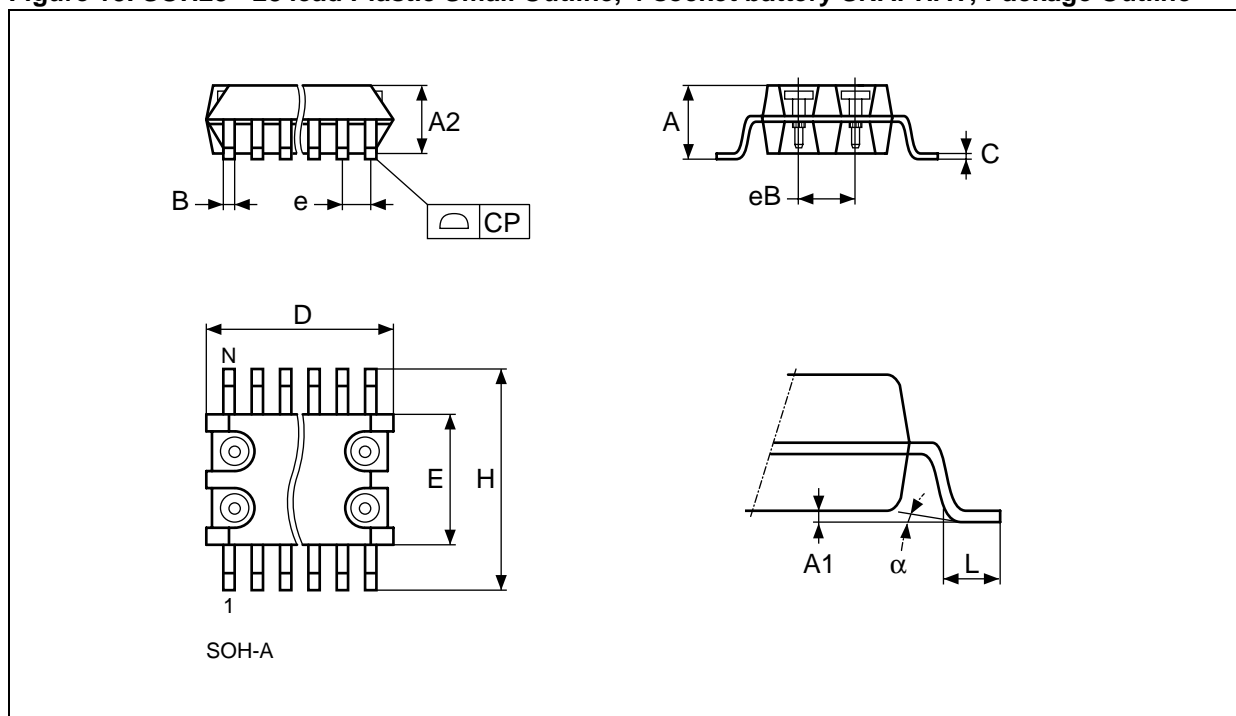

Drawing is not to scale.

M48T35, M48T35Y

Table 16. M4T28-BR12SH SNAPHAT Housing for 48 mAh Battery & Crystal, Package Mechanical Data

Symb	mm			inches		
	Typ	Min	Max	Typ	Min	Max
A			9.78			0.385
A1		6.73	7.24		0.265	0.285
A2		6.48	6.99		0.255	0.275
A3			0.38			0.015
B		0.46	0.56		0.018	0.022
D		21.21	21.84		0.835	0.860
E		14.22	14.99		0.560	0.590
eB		3.20	3.61		0.126	0.142
L		2.03	2.29		0.080	0.090

Figure 14. M4T28-BR12SH SNAPHAT Housing for 48 mAh Battery & Crystal, Package Outline

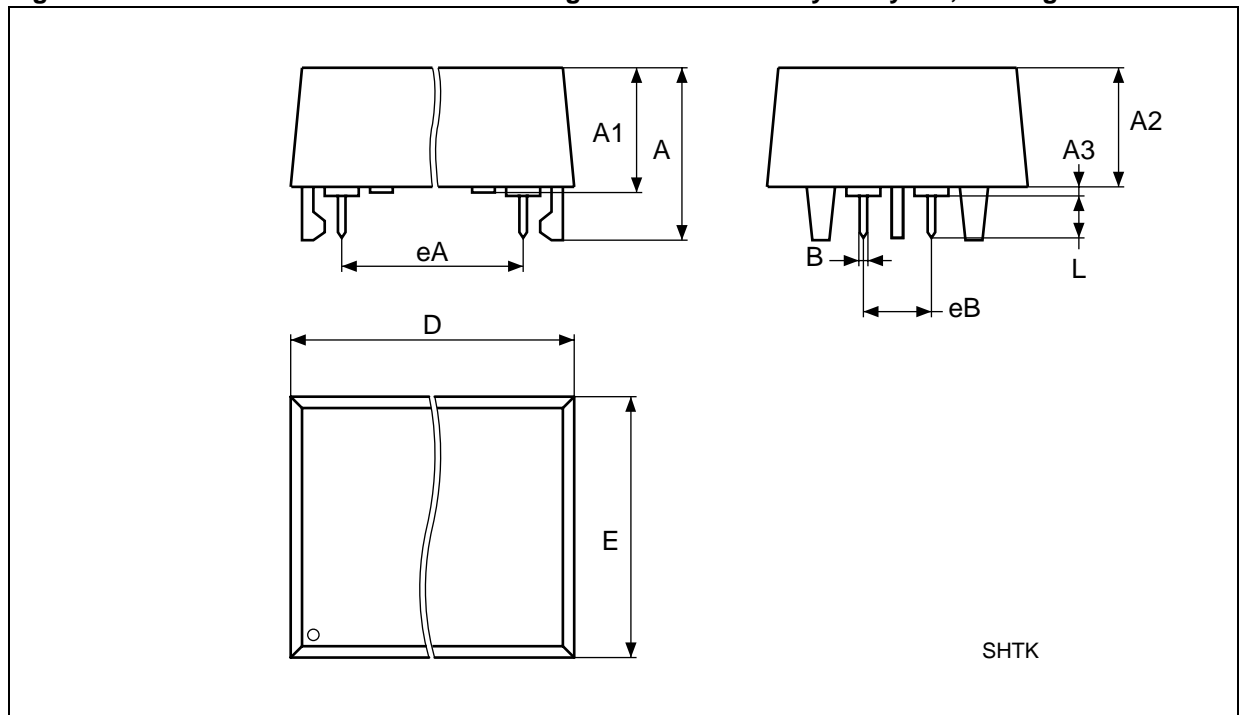

Drawing is not to scale.

Table 17. M4T28-BR12SH SNAPHAT Housing for 120 mAh Battery & Crystal, Package Mechanical Data

Symb	mm			inches		
	Typ	Min	Max	Typ	Min	Max
A			10.54			0.415
A1		8.00	8.51		0.315	0.335
A2		7.24	8.00		0.285	0.315
A3			0.38			0.015
B		0.46	0.56		0.018	0.022
D		21.21	21.84		0.835	0.860
E		17.27	18.03		0.680	0.710
eB		3.20	3.61		0.126	0.142
L		2.03	2.29		0.080	0.090

Figure 15. M4T28-BR12SH SNAPHAT Housing for 120 mAh Battery & Crystal, Package Outline

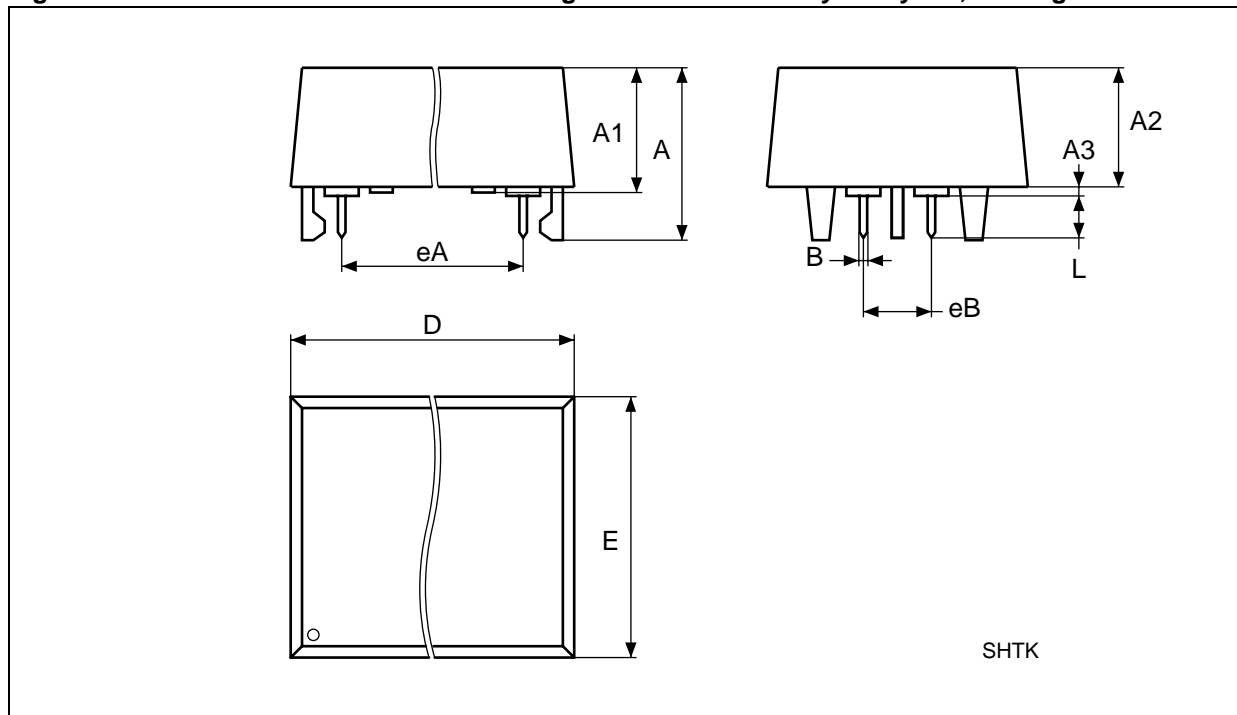

Drawing is not to scale.

Information furnished is believed to be accurate and reliable. However, STMicroelectronics assumes no responsibility for the consequences of use of such information nor for any infringement of patents or other rights of third parties which may result from its use. No license is granted by implication or otherwise under any patent or patent rights of STMicroelectronics. Specifications mentioned in this publication are subject to change without notice. This publication supersedes and replaces all information previously supplied. STMicroelectronics products are not authorized for use as critical components in life support devices or systems without express written approval of STMicroelectronics.

The ST logo is registered trademark of STMicroelectronics
© 2000 STMicroelectronics - All Rights Reserved

All other names are the property of their respective owners.

STMicroelectronics GROUP OF COMPANIES
Australia - Brazil - China - Finland - France - Germany - Hong Kong - India - Italy - Japan - Malaysia - Malta - Morocco -
Singapore - Spain - Sweden - Switzerland - United Kingdom - U.S.A.

<http://www.st.com>