



M34C02-W M34C02-L M34C02-R

2 Kbit Serial I²C Bus EEPROM
for DIMM serial presence detect

Feature summary

- Software Data Protection for lower 128 Bytes
- Two Wire I²C Serial Interface
- 400kHz Transfer Rates
- Single Supply Voltage:
 - 2.5 to 5.5V for M34C02-W
 - 2.2 to 5.5V for M34C02-L
 - 1.8 to 5.5V for M34C02-R
- Byte and Page Write (up to 16 bytes)
- Random and Sequential Read modes
- Self-Timed Programming Cycle
- Automatic Address Incrementing
- Enhanced ESD/Latch-Up Protection
- More than 1 million Write cycles
- More than 40 Year Data Retention
- Packages
 - ECOPACK® (RoHS compliant)

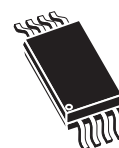

TSSOP8 (DW)
169 mil width



UFD8 (MB)
2x3mm² (MLP)

Contents

1	Summary description	6
2	Signal description	8
2.1	Serial Clock (SCL)	8
2.2	Serial Data (SDA)	8
2.3	Chip Enable (E0, E1, E2)	8
2.4	Write Control (\overline{WC})	8
2.5	Supply voltage (V_{CC})	9
2.5.1	Operating supply voltage V_{CC}	9
2.5.2	Internal device reset	9
2.5.3	Power-down	9
3	Device operation	11
3.1	Start Condition	11
3.2	Stop Condition	11
3.3	Acknowledge Bit (ACK)	11
3.4	Data Input	11
3.5	Memory Addressing	12
3.6	Setting the Software Write-Protection	13
3.7	Write Operations	14
3.7.1	Byte Write	14
3.7.2	Page Write	14
3.7.3	Minimizing system delays by polling on ACK	16
3.8	Read Operations	17
3.8.1	Random Address Read	17
3.8.2	Current Address Read	17
3.8.3	Sequential Read	17
3.8.4	Acknowledge in Read Mode	17
4	Use within a DRAM DIMM	19
4.1	Programming the M34C02-W, M34C02-L and M34C02-R	19
5	Initial delivery state	20

6	Maximum rating	21
7	DC and AC parameters	22
8	Package mechanical	27
9	Part numbering	29
10	Revision history	30

List of tables

Table 1.	Signal names	7
Table 2.	Device Select Code	10
Table 3.	Operating Modes	12
Table 4.	DRAM DIMM Connections	19
Table 5.	Absolute maximum ratings	21
Table 6.	Operating Conditions (M34C02-W)	22
Table 7.	Operating Conditions (M34C02-L)	22
Table 8.	Operating Conditions (M34C02-R)	22
Table 9.	AC Measurement Conditions	22
Table 10.	Input Parameters	23
Table 11.	DC Characteristics (M34C02-W)	23
Table 12.	DC Characteristics (M34C02-L)	24
Table 13.	DC Characteristics (M34C02-R)	25
Table 14.	AC Characteristics M34C02-W, M34C02-L, M34C02-R)	25
Table 15.	UFDFPN8 (MLP8) 8-lead Ultra thin Fine pitch Dual Flat Package No lead 2x3mm ² , Package Mechanical Data	27
Table 16.	TSSOP8 – 8 lead Thin Shrink Small Outline, package mechanical data	28
Table 17.	Ordering information scheme	29
Table 18.	Document revision history	30

List of figures

Figure 1.	Logic diagram	7
Figure 2.	TSSOP and MLP connections (top view)	7
Figure 3.	Chip Enable input connection	8
Figure 4.	Maximum R_P value versus bus parasitic capacitance (C) for an I ² C Bus	9
Figure 5.	I ² C bus protocol	10
Figure 6.	Setting the Write Protection Register (WC = 0)	12
Figure 7.	Result of setting the write protection.	13
Figure 8.	Write mode sequences in a non write-protected area	15
Figure 9.	Write cycle polling flowchart using ACK	16
Figure 10.	Read mode sequences.	18
Figure 11.	Serial presence detect block diagram.	20
Figure 12.	AC Measurement I/O Waveform.	22
Figure 13.	AC Waveforms	26
Figure 14.	UFDFPN8 (MLP8) 8-lead Ultra thin Fine pitch Dual Flat Package No lead 2x3mm ² , Package Outline	27
Figure 15.	TSSOP8 – 8 lead Thin Shrink Small Outline, package outline	28

1 Summary description

The M34C02-W, M34C02-L and M34C02-R are 2Kbit serial EEPROM memory able to lock permanently the data in its first half (from location 00h to 7Fh). This facility has been designed specifically for use in DRAM DIMMs (dual interline memory modules) with Serial Presence Detect. All the information concerning the DRAM module configuration (such as its access speed, its size, its organization) can be kept write protected in the first half of the memory.

This bottom half of the memory area can be write-protected using a specially designed software write protection mechanism. By sending the device a specific sequence, the first 128 Bytes of the memory become permanently write protected. Care must be taken when using this sequence as its effect cannot be reversed. In addition, the device allows the entire memory area to be write protected, using the \overline{WC} input (for example by tying this input to V_{CC}).

These I²C-compatible electrically erasable programmable memory (EEPROM) devices are organized as 256x8 bits.

In order to meet environmental requirements, ST offers these devices in ECOPACK® packages. ECOPACK® packages are Lead-free and RoHS compliant.

ECOPACK is an ST trademark. ECOPACK specifications are available at: www.st.com.

I²C uses a two wire serial interface, comprising a bi-directional data line and a clock line. The device carries a built-in 4-bit Device Type Identifier code (1010) in accordance with the I²C bus definition to access the memory area and a second Device Type Identifier Code (0110) to access the Protection Register. These codes are used together with three chip enable inputs (E2, E1, E0) so that up to eight 2Kbit devices may be attached to the I²C bus and selected individually.

The device behaves as a slave device in the I²C protocol, with all memory operations synchronized by the serial clock. Read and Write operations are initiated by a START condition, generated by the bus master. The START condition is followed by a Device Select Code and \overline{RW} bit (as described in [Table 2](#)), terminated by an acknowledge bit.

When writing data to the memory, the memory inserts an acknowledge bit during the 9th bit time, following the bus master's 8-bit transmission. When data is read by the bus master, the bus master acknowledges the receipt of the data byte in the same way. Data transfers are terminated by a STOP condition after an Ack for WRITE, and after a NoAck for READ.

Figure 1. Logic diagram

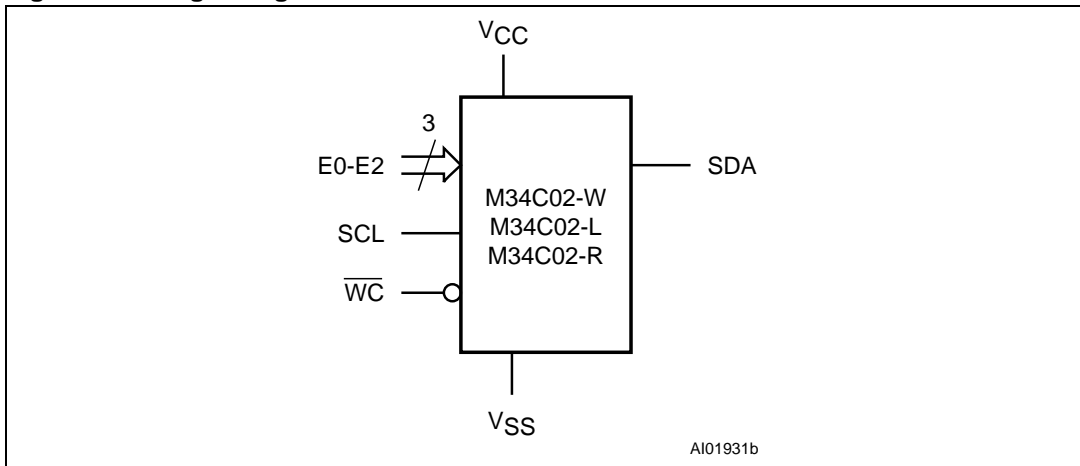
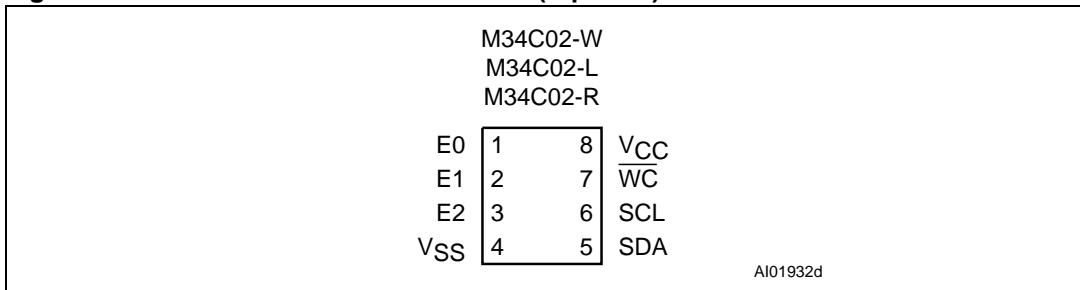

Figure 2. TSSOP and MLP connections (top view)



1. See [Section 8: Package mechanical](#) for package dimensions, and how to identify pin-1.

Table 1. Signal names

E0, E1, E2	Chip Enable
SDA	Serial Data
SCL	Serial Clock
WC	Write Control
V _{CC}	Supply Voltage
V _{SS}	Ground

2 Signal description

2.1 Serial Clock (SCL)

This input signal is used to strobe all data in and out of the device. In applications where this signal is used by slave devices to synchronize the bus to a slower clock, the bus master must have an open drain output, and a pull-up resistor can be connected from Serial Clock (SCL) to V_{CC} . ([Figure 4](#) indicates how the value of the pull-up resistor can be calculated). In most applications, though, this method of synchronization is not employed, and so the pull-up resistor is not necessary, provided that the bus master has a push-pull (rather than open drain) output.

2.2 Serial Data (SDA)

This bi-directional signal is used to transfer data in or out of the device. It is an open drain output that may be wire-OR'ed with other open drain or open collector signals on the bus. A pull up resistor must be connected from Serial Data (SDA) to V_{CC} . ([Figure 4](#) indicates how the value of the pull-up resistor can be calculated).

2.3 Chip Enable (E0, E1, E2)

These input signals are used to set the value that is to be looked for on the three least significant bits (b3, b2, b1) of the 7-bit Device Select Code. These inputs must be tied to V_{CC} or V_{SS} to establish the Device Select Code.

Figure 3. Chip Enable input connection

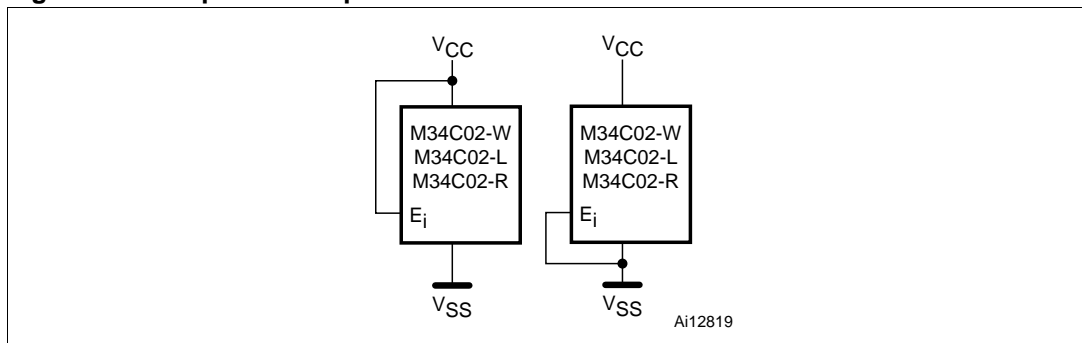

2.4 Write Control (\overline{WC})

This input signal is provided for protecting the contents of the whole memory from inadvertent write operations. Write Control (\overline{WC}) is used to enable (when driven Low) or disable (when driven High) write instructions to the entire memory area or to the Protection Register.

When Write Control (\overline{WC}) is tied Low or left unconnected, the write protection of the first half of the memory is determined by the status of the Protection Register.

2.5 Supply voltage (V_{CC})

2.5.1 Operating supply voltage V_{CC}

Prior to selecting the memory and issuing instructions to it, a valid and stable V_{CC} voltage within the specified [$V_{CC}(\min)$, $V_{CC}(\max)$] range must be applied (see [Table 6](#), [Table 7](#) and [Table 8](#)). In order to secure a stable DC supply voltage, it is recommended to decouple the V_{CC} line with a suitable capacitor (usually of the order of 10nF to 100nF) close to the V_{CC}/V_{SS} package pins.

This voltage must remain stable and valid until the end of the transmission of the instruction and, for a Write instruction, until the completion of the internal write cycle (t_W).

2.5.2 Internal device reset

In order to prevent inadvertent Write operations during Power-up, a Power On Reset (POR) circuit is included. At Power-up (continuous rise of V_{CC}), the device will not respond to any instruction until V_{CC} has reached the Power On Reset threshold voltage (this threshold is lower than the minimum V_{CC} operating voltage defined in [Table 6](#), [Table 7](#) and [Table 8](#)).

When V_{CC} has passed the POR threshold, the device is reset and in the Standby Power mode.

2.5.3 Power-down

At Power-down (where V_{CC} decreases continuously), as soon as V_{CC} drops from the normal operating voltage to below the Power On Reset threshold voltage, the device stops responding to any instruction sent to it.

During Power-down, the device must be deselected and in Standby Power mode (that is there should be no internal Write cycle in progress).

Figure 4. Maximum R_P value versus bus parasitic capacitance (C) for an I²C Bus

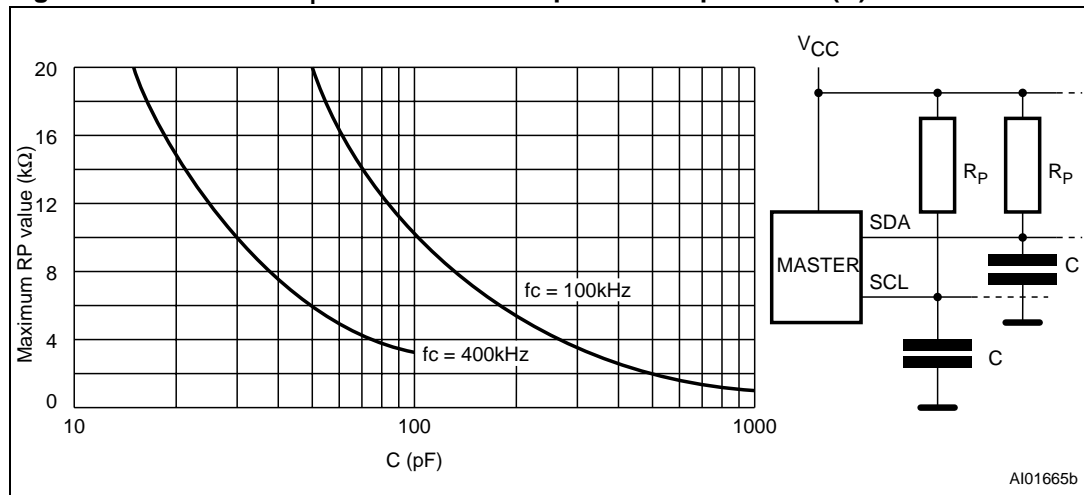

Figure 5. I²C bus protocol

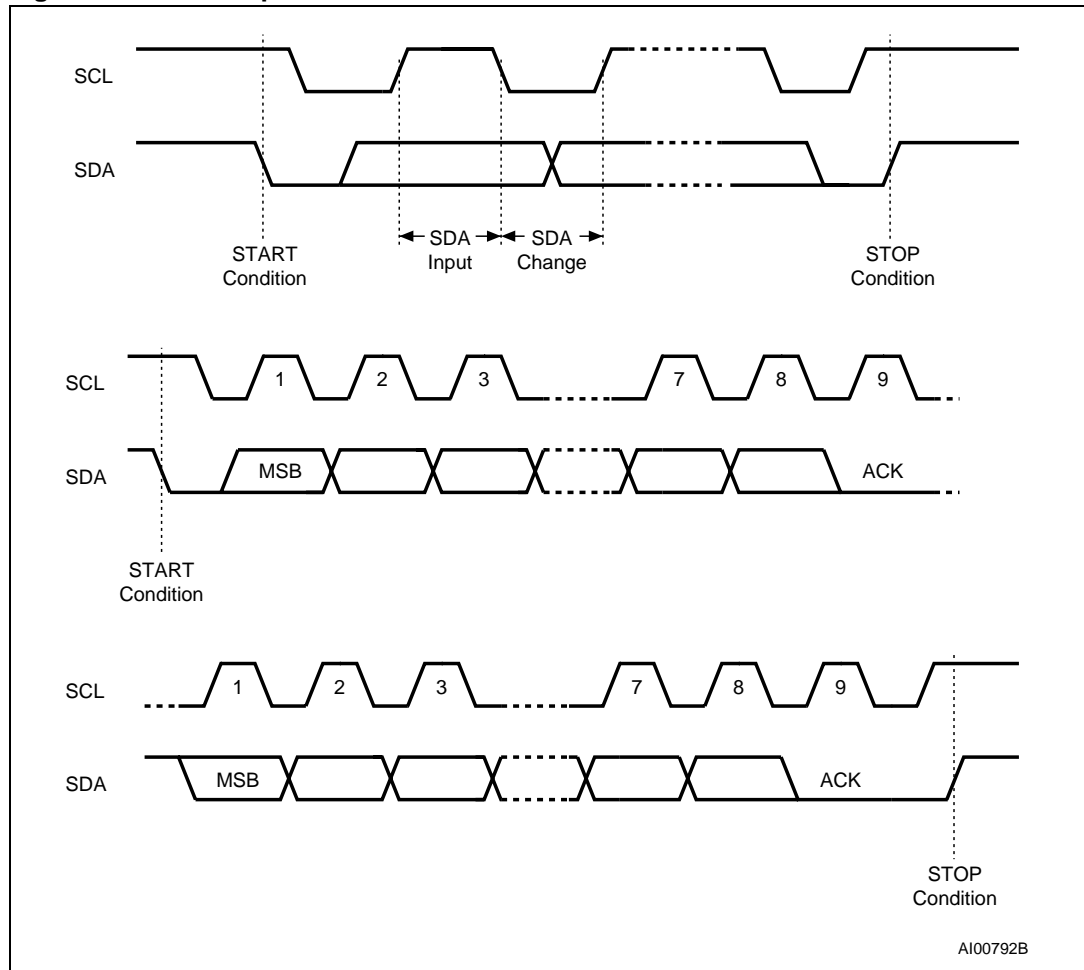

Table 2. Device Select Code

	Device Type Identifier ⁽¹⁾				Chip Enable Address ⁽²⁾			R \bar{W}
	b7	b6	b5	b4	b3	b2	b1	b0
Memory Area Select Code (two arrays)	1	0	1	0	E2	E1	E0	R \bar{W}
Protection Register Select Code	0	1	1	0	E2	E1	E0	R \bar{W}

1. The most significant bit, b7, is sent first.
2. E0, E1 and E2 are compared against the respective external pins on the memory device.

3 Device operation

The device supports the I²C protocol. This is summarized in [Figure 5](#). Any device that sends data on to the bus is defined to be a transmitter, and any device that reads the data to be a receiver. The device that controls the data transfer is known as the bus master, and the other as the slave device. A data transfer can only be initiated by the bus master, which will also provide the serial clock for synchronization. The memory device is always a slave in all communication.

3.1 Start Condition

Start is identified by a falling edge of Serial Data (SDA) while Serial Clock (SCL) is stable in the High state. A Start condition must precede any data transfer command. The device continuously monitors (except during a Write cycle) Serial Data (SDA) and Serial Clock (SCL) for a Start condition, and will not respond unless one is given.

3.2 Stop Condition

Stop is identified by a rising edge of Serial Data (SDA) while Serial Clock (SCL) is stable and driven High. A Stop condition terminates communication between the device and the bus master. A Read command that is followed by NoAck can be followed by a Stop condition to force the device into the Stand-by mode. A Stop condition at the end of a Write command triggers the internal EEPROM Write cycle.

3.3 Acknowledge Bit (ACK)

The acknowledge bit is used to indicate a successful byte transfer. The bus transmitter, whether it be bus master or slave device, releases Serial Data (SDA) after sending eight bits of data. During the 9th clock pulse period, the receiver pulls Serial Data (SDA) Low to acknowledge the receipt of the eight data bits.

3.4 Data Input

During data input, the device samples Serial Data (SDA) on the rising edge of Serial Clock (SCL). For correct device operation, Serial Data (SDA) must be stable during the rising edge of Serial Clock (SCL), and the Serial Data (SDA) signal must change *only* when Serial Clock (SCL) is driven Low.

3.5 Memory Addressing

To start communication between the bus master and the slave device, the bus master must initiate a Start condition. Following this, the bus master sends the Device Select Code, shown in [Table 2](#) (on Serial Data (SDA), most significant bit first).

The Device Select Code consists of a 4-bit Device Type Identifier, and a 3-bit Chip Enable "Address" (E2, E1, E0). To address the memory array, the 4-bit Device Type Identifier is 1010b; to address the Protection Register, it is 0110b.

Up to eight memory devices can be connected on a single I²C bus. Each one is given a unique 3-bit code on the Chip Enable (E0, E1, E2) inputs. When the Device Select Code is received, the device only responds if the Chip Enable Address is the same as the value on the Chip Enable (E0, E1, E2) inputs.

The 8th bit is the Read/Write bit (\overline{RW}). This bit is set to 1 for Read and 0 for Write operations.

If a match occurs on the Device Select code, the corresponding device gives an acknowledgment on Serial Data (SDA) during the 9th bit time. If the device does not match the Device Select code, it deselects itself from the bus, and goes into Stand-by mode.

Table 3. Operating Modes

Mode	\overline{RW} bit	$\overline{WC}^{(1)}$	Bytes	Initial Sequence
Current Address Read	1	X	1	START, Device Select, $\overline{RW} = 1$
Random Address Read	0	X	1	START, Device Select, $\overline{RW} = 0$, Address
	1	X		reSTART, Device Select, $\overline{RW} = 1$
Sequential Read	1	X	≥ 1	Similar to Current or Random Address Read
Byte Write	0	V_{IL}	1	START, Device Select, $\overline{RW} = 0$
Page Write	0	V_{IL}	≤ 16	START, Device Select, $\overline{RW} = 0$

1. X = V_{IH} or V_{IL} .

Figure 6. Setting the Write Protection Register ($\overline{WC} = 0$)

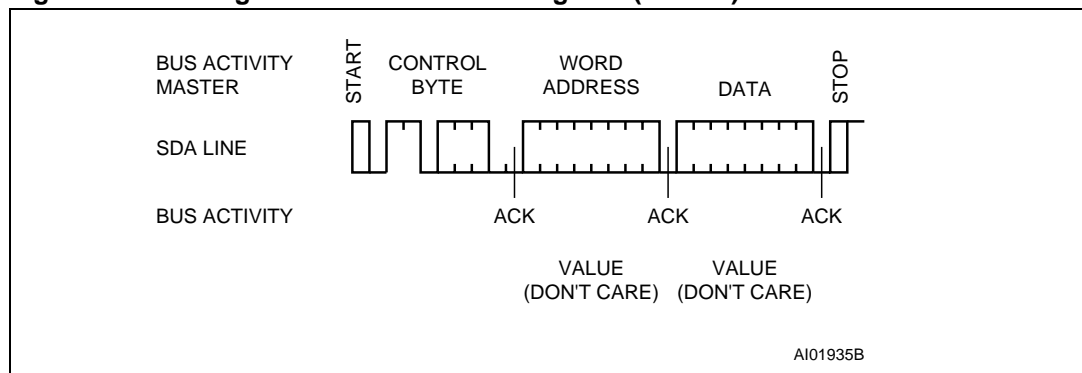

3.6 Setting the Software Write-Protection

The M34C02-W has a hardware write-protection feature, using the Write Control (\overline{WC}) signal. This signal can be driven High or Low, and must be held constant for the whole instruction sequence. When Write Control (\overline{WC}) is held Low, the whole memory array (addresses 00h to FFh) is write protected. When Write Control (\overline{WC}) is held High, the write protection of the memory array is dependent on whether software write-protection has been set.

Software write-protection allows the bottom half of the memory area (addresses 00h to 7Fh) to be permanently write protected irrespective of subsequent states of the Write Control (\overline{WC}) signal.

The write protection feature is activated by writing once to the Protection Register. The Protection Register is accessed with the device select code set to 0110b (as shown in [Table 2](#)), and the E2, E1 and E0 bits set according to the states being applied on the E2, E1 and E0 signals. As for any other write command, Write Control (\overline{WC}) needs to be held Low. Address and data bytes must be sent with this command, but their values are all ignored, and are treated as Don't Care. Once the Protection Register has been written, the write protection of the first 128 Bytes of the memory is enabled, and it is not possible to unprotect these 128 Bytes of the memory, even if the device is powered off and on, and regardless the state of Write Control (\overline{WC}).

When the Protection Register has been written, the M34C02-W no longer responds to the device type identifier 0110b in either read or write mode.

Figure 7. Result of setting the write protection

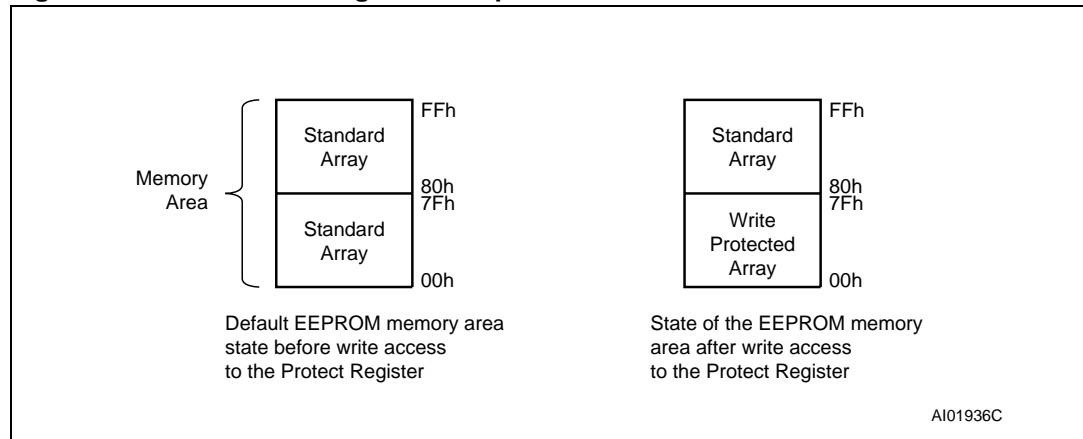

3.7 Write Operations

Following a Start condition the bus master sends a Device Select Code with the \overline{RW} bit reset to 0. The device acknowledges this, as shown in [Figure 8](#), and waits for an address byte. The device responds to the address byte with an acknowledge bit, and then waits for the data byte.

When the bus master generates a Stop condition immediately after the Ack bit (in the “10th bit” time slot), either at the end of a Byte Write or a Page Write, the internal memory Write cycle is triggered. A Stop condition at any other time slot does not trigger the internal Write cycle.

During the internal Write cycle, Serial Data (SDA) and Serial Clock (SCL) are ignored, and the device does not respond to any requests.

3.7.1 Byte Write

After the Device Select Code and the address byte, the bus master sends one data byte. If the addressed location is hardware write-protected, the device replies to the data byte with NoAck, and the location is not modified. If, instead, the addressed location is not Write-protected, the device replies with Ack. The bus master terminates the transfer by generating a Stop condition, as shown in [Figure 8](#).

3.7.2 Page Write

The Page Write mode allows up to 16 bytes to be written in a single Write cycle, provided that they are all located in the same page in the memory: that is, the most significant memory address bits are the same. If more bytes are sent than will fit up to the end of the page, a condition known as ‘roll-over’ occurs. This should be avoided, as data starts to become overwritten in an implementation dependent way.

The bus master sends from 1 to 16 bytes of data, each of which is acknowledged by the device if Write Control (\overline{WC}) is Low. If the addressed location is hardware write-protected, the device replies to the data byte with NoAck, and the locations are not modified. After each byte is transferred, the internal byte address counter (the 4 least significant address bits only) is incremented. The transfer is terminated by the bus master generating a Stop condition.

Figure 8. Write mode sequences in a non write-protected area

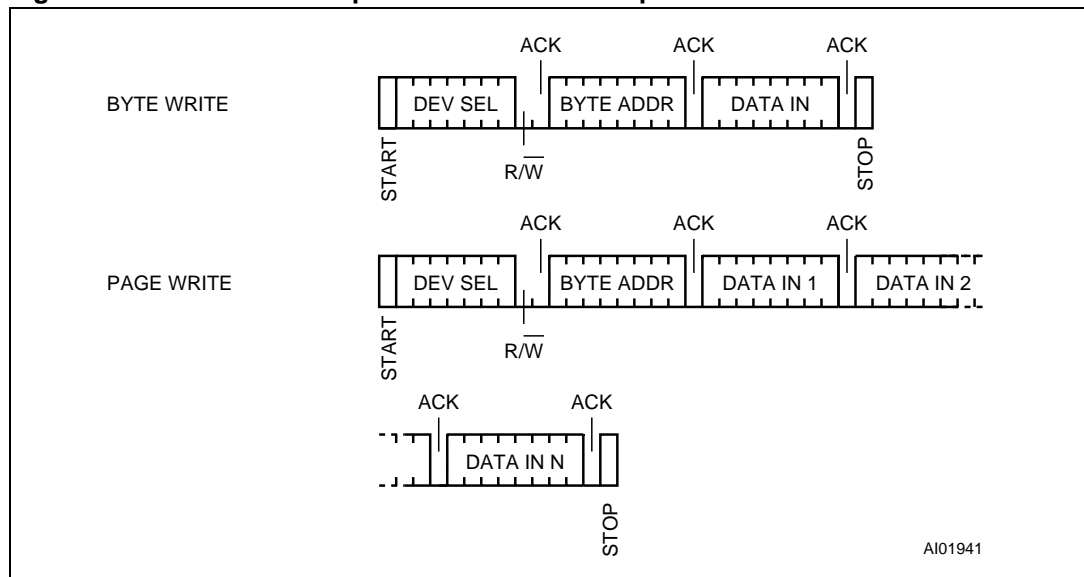

AI01941

3.7.3 Minimizing system delays by polling on ACK

During the internal Write cycle, the device disconnects itself from the bus, and writes a copy of the data from its internal latches to the memory cells. The maximum Write time (t_w) is shown in [Table 14](#) and [Table 16](#), but the typical time is shorter. To make use of this, a polling sequence can be used by the bus master.

The sequence, as shown in [Figure 9](#), is:

- Initial condition: a Write cycle is in progress.
- Step 1: the bus master issues a Start condition followed by a Device Select Code (the first byte of the new instruction).
- Step 2: if the device is busy with the internal Write cycle, no Ack will be returned and the bus master goes back to Step 1. If the device has terminated the internal Write cycle, it responds with an Ack, indicating that the device is ready to receive the second part of the instruction (the first byte of this instruction having been sent during Step 1).

Figure 9. Write cycle polling flowchart using ACK

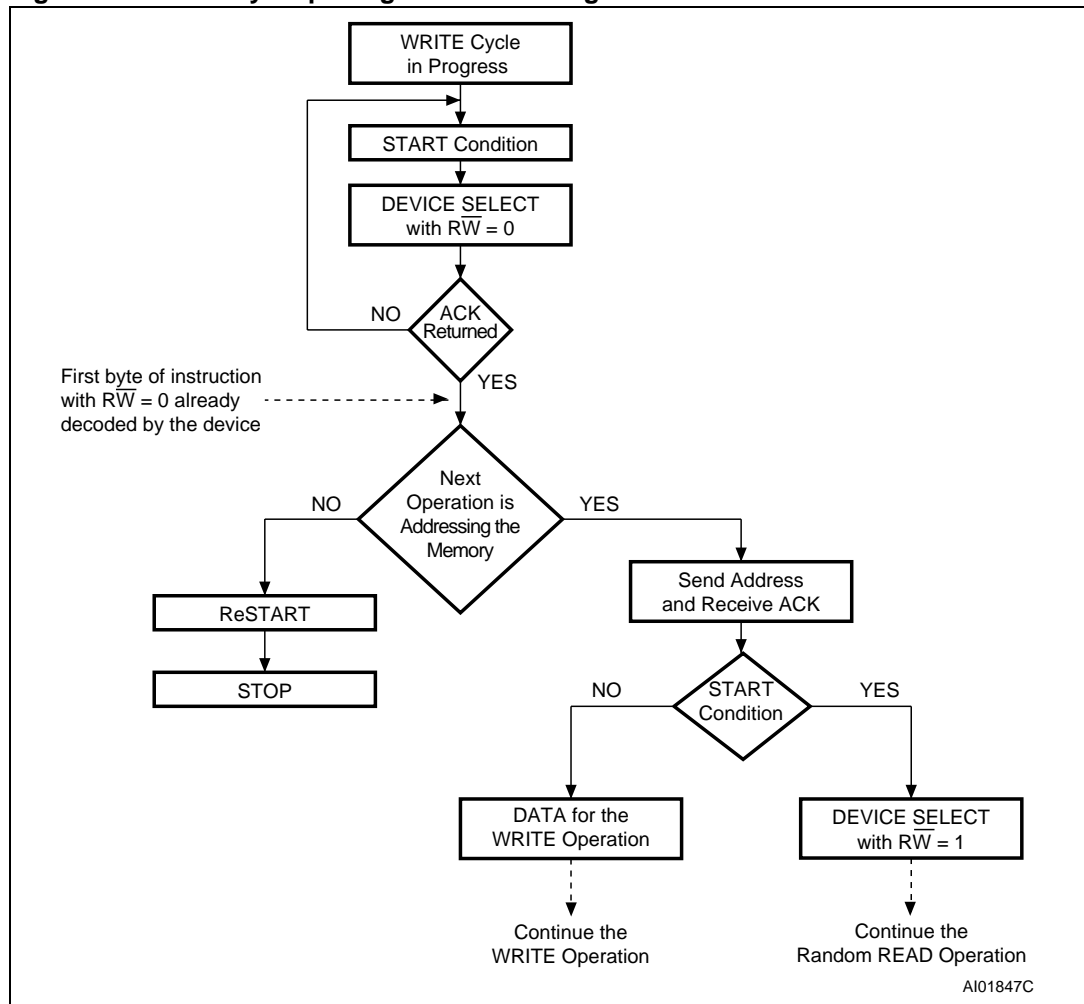

3.8 Read Operations

Read operations are performed independently of whether hardware or software protection has been set.

The device has an internal address counter which is incremented each time a byte is read.

3.8.1 Random Address Read

A dummy Write is first performed to load the address into this address counter (as shown in [Figure 10](#)) but *without* sending a Stop condition. Then, the bus master sends another Start condition, and repeats the Device Select Code, with the \overline{RW} bit set to 1. The device acknowledges this, and outputs the contents of the addressed byte. The bus master must *not* acknowledge the byte, and terminates the transfer with a Stop condition.

3.8.2 Current Address Read

For the Current Address Read operation, following a Start condition, the bus master only sends a Device Select Code with the \overline{RW} bit set to 1. The device acknowledges this, and outputs the byte addressed by the internal address counter. The counter is then incremented. The bus master terminates the transfer with a Stop condition, as shown in [Figure 10](#), *without* acknowledging the byte.

3.8.3 Sequential Read

This operation can be used after a Current Address Read or a Random Address Read. The bus master *does* acknowledge the data byte output, and sends additional clock pulses so that the device continues to output the next byte in sequence. To terminate the stream of bytes, the bus master must *not* acknowledge the last byte, and *must* generate a Stop condition, as shown in [Figure 10](#).

The output data comes from consecutive addresses, with the internal address counter automatically incremented after each byte output. After the last memory address, the address counter 'rolls-over', and the device continues to output data from memory address 00h.

3.8.4 Acknowledge in Read Mode

For all Read commands, the device waits, after each byte read, for an acknowledgment during the 9th bit time. If the bus master does not drive Serial Data (SDA) Low during this time, the device terminates the data transfer and switches to its Stand-by mode.

Figure 10. Read mode sequences

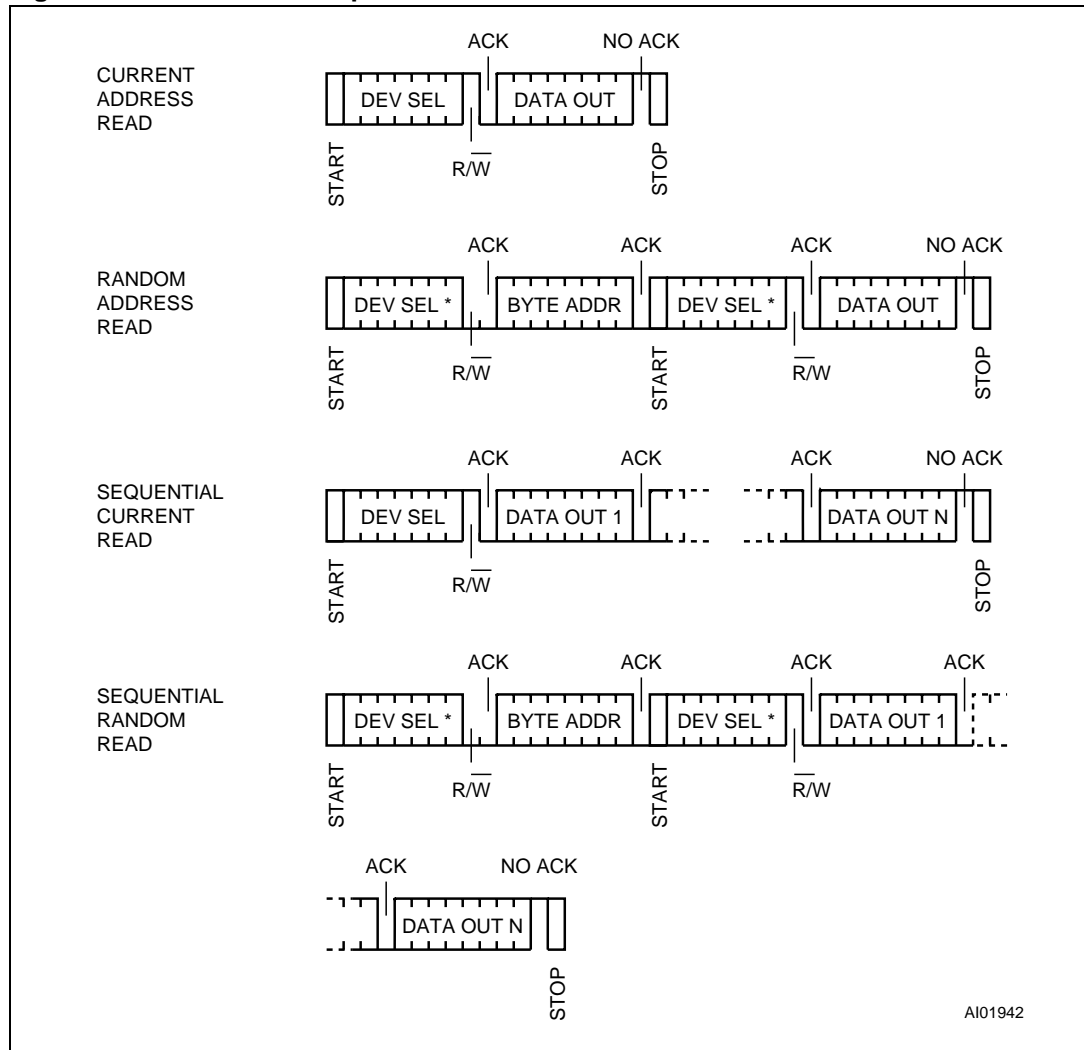

1. The seven most significant bits of the Device Select Code of a Random Read (in the 1st and 3rd bytes) must be identical.

4 Use within a DRAM DIMM

In the application, the M34C02-W, M34C02-L and M34C02-R are soldered directly in the printed circuit module. The 3 Chip Enable inputs (pins 1, 2 and 3) are wired at V_{CC} or V_{SS} through the DIMM socket (see [Table 4](#)). The pull-up resistors needed for normal behavior of the I²C bus are connected on the I²C bus of the mother-board (as shown in [Figure 11](#)).

The Write Control (\overline{WC}) of the M34C02-W, M34C02-L and M34C02-R can be left unconnected. However, connecting it to V_{SS} is recommended, to maintain full read and write access.

4.1 Programming the M34C02-W, M34C02-L and M34C02-R

When the device is delivered, full read and write access is given to the whole memory array. It is recommended that the first step is to use the test equipment to write the module information (such as its access speed, its size, its organization) to the first half of the memory, starting from the first memory location. When the data has been validated, the test equipment can send a Write command to the Protection Register, using the device select code '01100000b' followed by an address and data byte (made up of Don't Care values) as shown in [Figure 6](#). The first 128 bytes of the memory area are then write-protected, and the M34C02-W, M34C02-L and M34C02-R will no longer respond to the specific device select code '0110000xb'. It is not possible to reverse this sequence.

Table 4. DRAM DIMM Connections

DIMM Position	E2	E1	E0
0	V_{SS}	V_{SS}	V_{SS}
1	V_{SS}	V_{SS}	V_{CC}
2	V_{SS}	V_{CC}	V_{SS}
3	V_{SS}	V_{CC}	V_{CC}
4	V_{CC}	V_{SS}	V_{SS}
5	V_{CC}	V_{SS}	V_{CC}
6	V_{CC}	V_{CC}	V_{SS}
7	V_{CC}	V_{CC}	V_{CC}

5 Initial delivery state

The device is delivered with all bits in the memory array set to 1 (each Byte contains FFh).

Figure 11. Serial presence detect block diagram

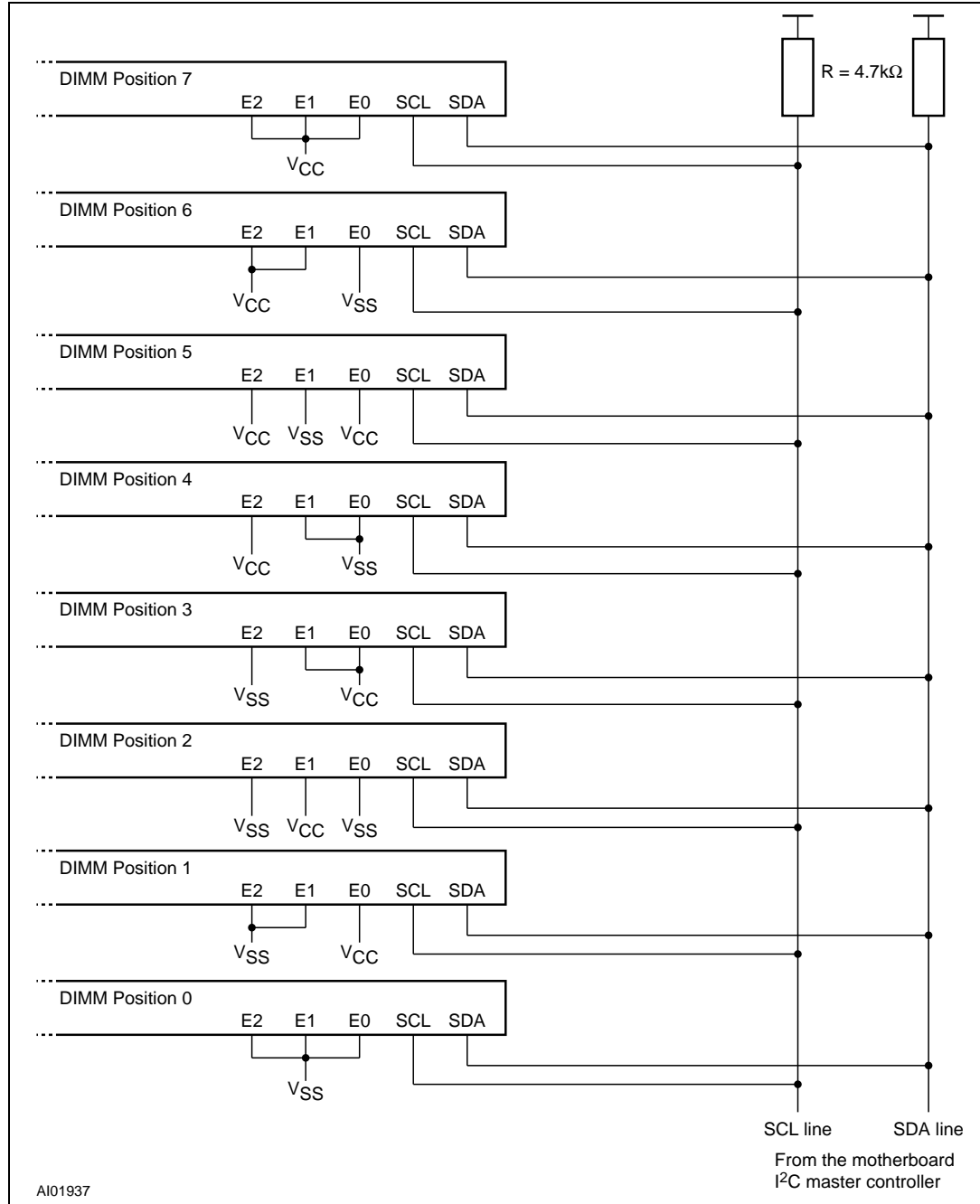

1. E0, E1 and E2 are wired at each DIMM socket in a binary sequence for a maximum of 8 devices.
2. Common clock and common data are shared across all the devices.
3. Pull-up resistors are required on all SDA and SCL bus lines (typically 4.7 kΩ) because these lines are open drain when used as outputs.

6 Maximum rating

Stressing the device above the rating listed in the Absolute Maximum Ratings" table may cause permanent damage to the device. These are stress ratings only and operation of the device at these or any other conditions above those indicated in the Operating sections of this specification is not implied. Exposure to Absolute Maximum Rating conditions for extended periods may affect device reliability. Refer also to the STMicroelectronics SURE Program and other relevant quality documents.

Table 5. Absolute maximum ratings

Symbol	Parameter	Min.	Max.	Unit
T_A	Ambient Operating Temperature	-40	90	°C
T_{STG}	Storage Temperature	-65	150	°C
T_{LEAD}	Lead Temperature during Soldering ⁽¹⁾	See ⁽¹⁾		°C
V_{IO}	Input or Output Voltage	-0.50	6.5	V
V_{CC}	Supply Voltage	-0.50	6.5	V
V_{ESD}	Electrostatic Discharge Voltage (Human Body model) ⁽²⁾	-4000	4000	V

1. Compliant with JEDEC Std J-STD-020C (for small body, Sn-Pb or Pb assembly), the ST ECOPACK[®] 7191395 specification, and the European directive on Restrictions on Hazardous Substances (RoHS) 2002/95/EU.
2. JEDEC Std JESD22-A114A (C1=100 pF, R1=1500 Ω , R2=500 Ω)

7 DC and AC parameters

This section summarizes the operating and measurement conditions, and the DC and AC characteristics of the device. The parameters in the DC and AC Characteristic tables that follow are derived from tests performed under the Measurement Conditions summarized in the relevant tables. Designers should check that the operating conditions in their circuit match the measurement conditions when relying on the quoted parameters.

Table 6. Operating Conditions (M34C02-W)

Symbol	Parameter	Min.	Max.	Unit
V_{CC}	Supply Voltage	2.5	5.5	V
T_A	Ambient Operating Temperature	-40	85	°C

Table 7. Operating Conditions (M34C02-L)

Symbol	Parameter	Min.	Max.	Unit
V_{CC}	Supply Voltage	2.2	5.5	V
T_A	Ambient Operating Temperature	-40	85	°C

Table 8. Operating Conditions (M34C02-R)

Symbol	Parameter	Min.	Max.	Unit
V_{CC}	Supply Voltage	1.8	5.5	V
T_A	Ambient Operating Temperature	-40	85	°C

Table 9. AC Measurement Conditions

Symbol	Parameter	Min.	Max.	Unit
C_L	Load Capacitance	100		pF
	Input Rise and Fall Times		50	ns
	Input Levels	0.2 V_{CC} to 0.8 V_{CC}		V
	Input and Output Timing Reference Levels	0.3 V_{CC} to 0.7 V_{CC}		V

Figure 12. AC Measurement I/O Waveform

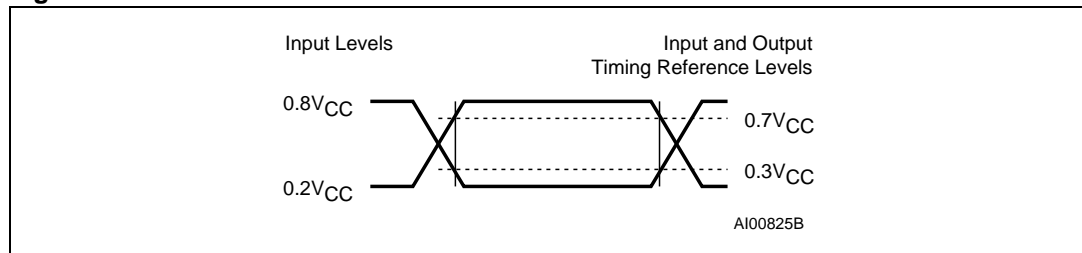

Table 10. Input Parameters

Symbol	Parameter ^{(1),(2)}	Test Condition	Min.	Max.	Unit
C_{IN}	Input Capacitance (SDA)			8	pF
C_{IN}	Input Capacitance (other pins)			6	pF
Z_{WCL}	\overline{WC} Input Impedance	$V_{IN} < 0.3 V$	15	70	k Ω
Z_{WCH}	\overline{WC} Input Impedance	$V_{IN} > 0.7V_{CC}$	500		k Ω
t_{NS}	Pulse width ignored (Input Filter on SCL and SDA)	Single glitch		100	ns

1. $T_A = 25^\circ C$, $f = 400kHz$

2. Sampled only, not 100% tested.

Table 11. DC Characteristics (M34C02-W)

Symbol	Parameter	Test Condition (in addition to those in Table 6)	Min.	Max.	Unit
I_{LI}	Input Leakage Current (SCL, SDA, E0, E1, and E2)	$V_{IN} = V_{SS}$ or V_{CC}		± 2	μA
I_{LO}	Output Leakage Current	$V_{OUT} = V_{SS}$ or V_{CC} , SDA in Hi-Z		± 2	μA
I_{CC}	Supply Current	$V_{CC}=5V$, $f_c=400kHz$ (rise/fall time < 30ns)		2	mA
		$V_{CC}=2.5V$, $f_c=400kHz$ (rise/fall time < 30ns)		1	mA
I_{CC1}	Stand-by Supply Current	$V_{IN} = V_{SS}$ or V_{CC} , for $2.5V < V_{CC} = < 5.5V$		1	μA
V_{IL}	Input Low Voltage ⁽¹⁾		-0.45	$0.3V_{CC}$	V
V_{IH}	Input High Voltage ⁽¹⁾		$0.7V_{CC}$	$V_{CC}+1$	V
V_{OL}	Output Low Voltage	$I_{OL} = 2.1mA$ when $V_{CC} = 2.5V$ or $I_{OL} = 3mA$ when $V_{CC} = 5.5V$		0.4	V

1. The voltage source driving only E0, E1 and E2 inputs must provide an impedance of less than 1k Ω .

Table 12. DC Characteristics (M34C02-L)

Symbol	Parameter	Test Condition (in addition to those in Table 7)	Min.	Max.	Unit
I_{LI}	Input Leakage Current (SCL, SDA)	$V_{IN} = V_{SS}$ or V_{CC}		± 2	μA
I_{LO}	Output Leakage Current	$V_{OUT} = V_{SS}$ or V_{CC} , SDA in Hi-Z		± 2	μA
I_{CC}	Supply Current	$V_{CC} = 5V$, $f_c = 400kHz$ (rise/fall time < 30ns)		2	mA
		$V_{CC} = 2.5V$, $f_c = 400kHz$ (rise/fall time < 30ns)		1	mA
		$V_{CC} = 2.2V$, $f_c = 400kHz$ (rise/fall time < 30ns)		1	mA
I_{CC1}	Stand-by Supply Current	$V_{IN} = V_{SS}$ or V_{CC} , $V_{CC} = 5V$		1	μA
		$V_{IN} = V_{SS}$ or V_{CC} , $2.2V \leq V_{CC} < 2.5V$		0.5	μA
V_{IL}	Input Low Voltage (E2, E1, E0, SCL, SDA)		-0.3	$0.3V_{CC}$	V
	Input Low Voltage (\overline{WC})		-0.3	0.5	V
V_{IH}	Input High Voltage (E2, E1, E0, SCL, SDA, \overline{WC})		$0.7V_{CC}$	$V_{CC} + 1$	V
V_{OL}	Output Low Voltage	$I_{OL} = 3mA$, $V_{CC} = 5V$		0.4	V
		$I_{OL} = 2.1mA$, $2.2V \leq V_{CC} < 2.5V$		0.4	V

Table 13. DC Characteristics (M34C02-R)

Symbol	Parameter	Test Condition (in addition to those in Table 8)	Min.	Max.	Unit
I_{LI}	Input Leakage Current (SCL, SDA, E0, E1 and E2)	$V_{IN} = V_{SS}$ or V_{CC}		± 2	μA
I_{LO}	Output Leakage Current	$V_{OUT} = V_{SS}$ or V_{CC} , SDA in Hi-Z		± 2	μA
I_{CC}	Supply Current	$V_{CC} = 5V$, $f_c = 400kHz$ (rise/fall time < 30ns)		2	mA
		$V_{CC} = 2.5V$, $f_c = 400kHz$ (rise/fall time < 30ns)		1	mA
		$V_{CC} = 1.8V$, $f_c = 400kHz$ (rise/fall time < 30ns)		1	mA
I_{CC1}	Stand-by Supply Current	$V_{IN} = V_{SS}$ or V_{CC} , $V_{CC} = 5V$		1	μA
		$V_{IN} = V_{SS}$ or V_{CC} , $1.8V \leq V_{CC} < 2.5V$		0.5	μA
V_{IL}	Input Low Voltage ⁽¹⁾	$2.5V \leq V_{CC} \leq 5.5V$	-0.3	$0.3V_{CC}$	V
		$1.8V \leq V_{CC} < 2.5V$	-0.3	$0.25V_{CC}$	V
V_{IH}	Input High Voltage ⁽¹⁾		$0.7V_{CC}$	$V_{CC}+1$	V
V_{OL}	Output Low Voltage	$I_{OL} = 3mA$, $V_{CC} = 5V$		0.4	V
		$I_{OL} = 2.1mA$, $2.2V \leq V_{CC} < 2.5V$		0.4	V
		$I_{OL} = 0.15mA$, $V_{CC} = 1.8V$		0.2	V

1. The voltage source driving only E0, E1 and E2 inputs must provide an impedance of less than 1k Ω .

Table 14. AC Characteristics M34C02-W, M34C02-L, M34C02-R)

Test conditions specified in Table 9 and Table 6 or Table 7					
Symbol	Alt.	Parameter	Min.	Max.	Unit
f_c	f_{SCL}	Clock Frequency		400	kHz
t_{CHCL}	t_{HIGH}	Clock Pulse Width High	600		ns
t_{CLCH}	t_{LOW}	Clock Pulse Width Low	1300		ns
$t_{DL1DL2}^{(1)}$	t_F	SDA Fall Time	20	300	ns
t_{DXCX}	$t_{SU:DAT}$	Data In Set Up Time	100		ns
t_{CLDX}	$t_{HD:DAT}$	Data In Hold Time	0		ns
t_{CLQX}	t_{DH}	Data Out Hold Time	200		ns
$t_{CLQV}^{(2)}$	t_{AA}	Clock Low to Next Data Valid (Access Time)	200	900	ns
$t_{CHDX}^{(3)}$	$t_{SU:STA}$	Start Condition Set Up Time	600		ns
t_{DLCL}	$t_{HD:STA}$	Start Condition Hold Time	600		ns
t_{CHDH}	$t_{SU:STO}$	Stop Condition Set Up Time	600		ns
t_{DHDL}	t_{BUF}	Time between Stop Condition and Next Start Condition	1300		ns
t_W	t_{WR}	Write Time		10	ms

1. Sampled only, not 100% tested.

2. To avoid spurious START and STOP conditions, a minimum delay is placed between SCL=1 and the falling or rising edge of SDA.

3. For a reSTART condition, or following a Write cycle.

Figure 13. AC Waveforms

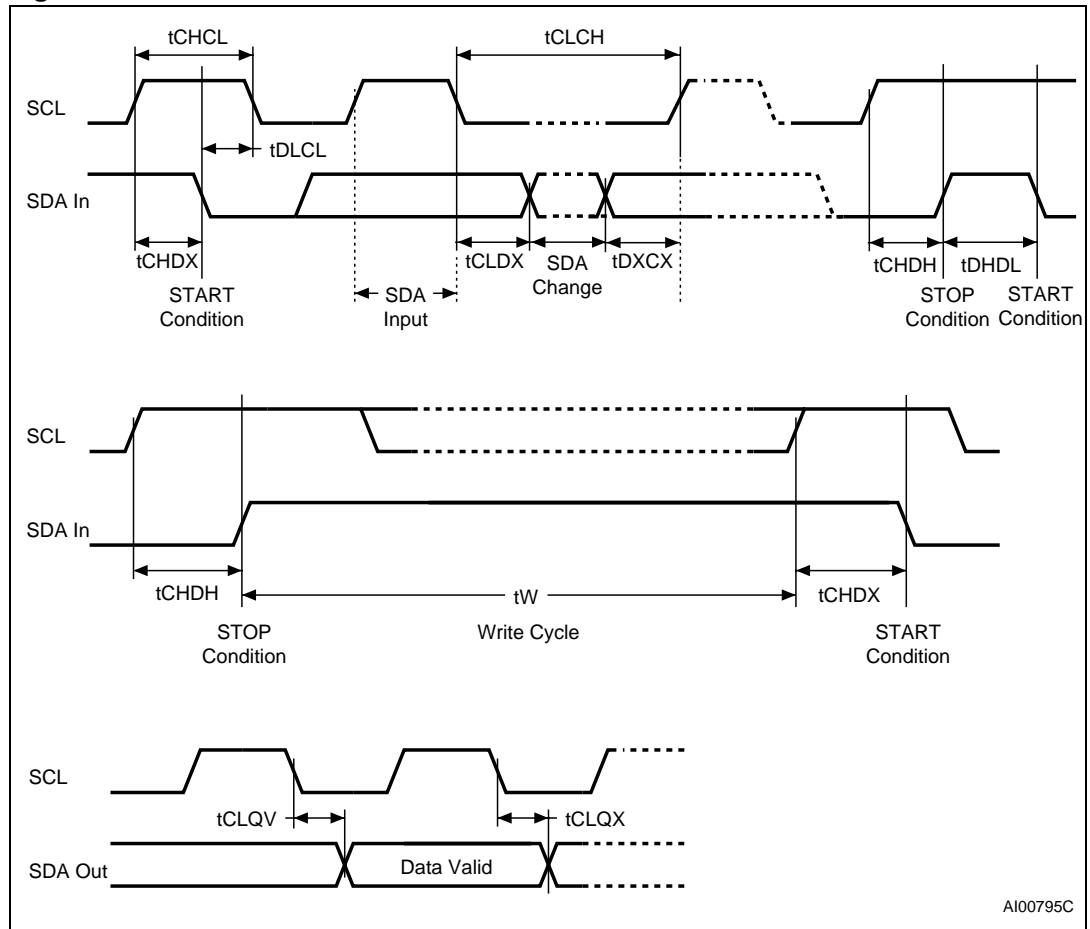

8 Package mechanical

Figure 14. UFDFPN8 (MLP8) 8-lead Ultra thin Fine pitch Dual Flat Package No lead 2x3mm², Package Outline

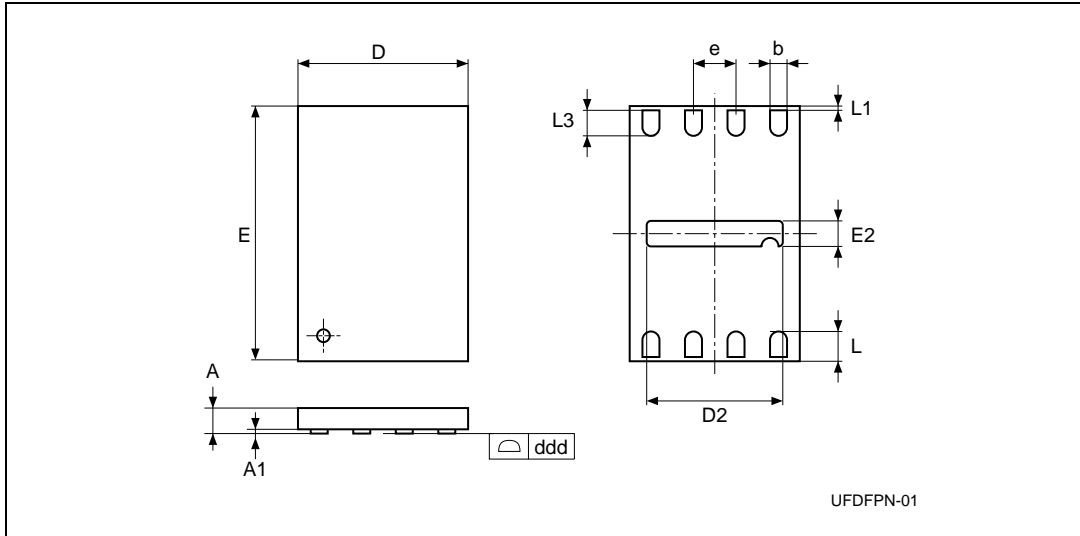

1. Drawing is not to scale.
2. The central pad (the area E2 by D2 in the above illustration) is pulled, internally, to V_{SS} . It must not be allowed to be connected to any other voltage or signal line on the PCB, for example during the soldering process.

Table 15. UFDFPN8 (MLP8) 8-lead Ultra thin Fine pitch Dual Flat Package No lead 2x3mm², Package Mechanical Data

Symbol	millimeters			inches		
	Typ.	Min.	Max.	Typ.	Min.	Max.
A	0.55	0.50	0.60	0.022	0.020	0.024
A1		0.00	0.05		0.000	0.002
b	0.25	0.20	0.30	0.010	0.008	0.012
D	2.00			0.079		
D2		1.55	1.65		0.061	0.065
ddd			0.05			0.002
E	3.00			0.118		
E2		0.15	0.25		0.006	0.010
e	0.50	–	–	0.020	–	–
L	0.45	0.40	0.50	0.018	0.016	0.020
L1			0.15			0.006
L3		0.30			0.012	
N	8			8		

Figure 15. TSSOP8 – 8 lead Thin Shrink Small Outline, package outline

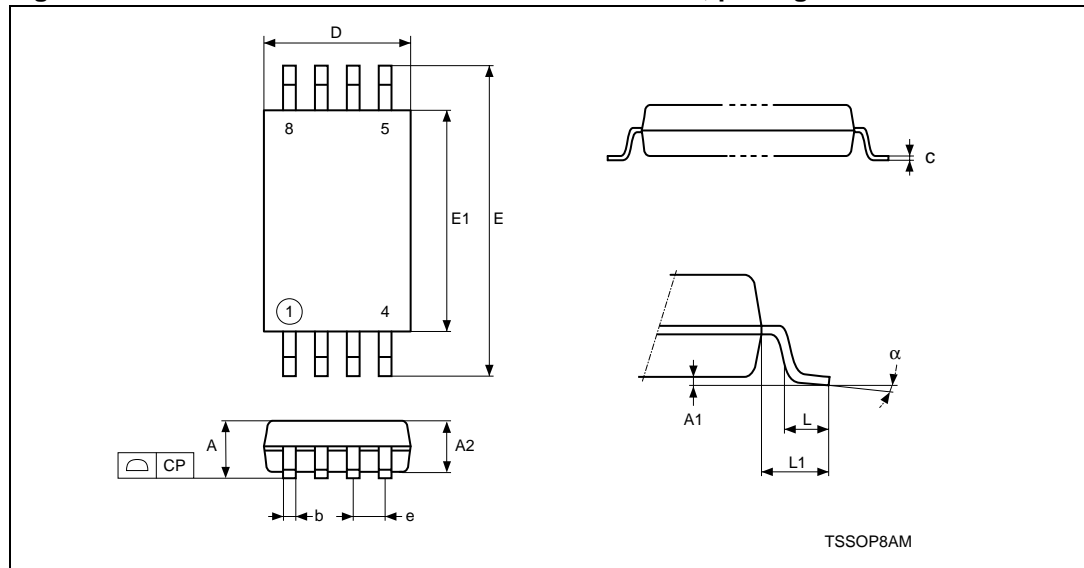

1. Drawing is not to scale.

Table 16. TSSOP8 – 8 lead Thin Shrink Small Outline, package mechanical data

Symbol	millimeters			inches		
	Typ.	Min.	Max.	Typ.	Min.	Max.
A			1.200			0.0472
A1		0.050	0.150		0.0020	0.0059
A2	1.000	0.800	1.050	0.0394	0.0315	0.0413
b		0.190	0.300		0.0075	0.0118
c		0.090	0.200		0.0035	0.0079
CP			0.100			0.0039
D	3.000	2.900	3.100	0.1181	0.1142	0.1220
e	0.650	–	–	0.0256	–	–
E	6.400	6.200	6.600	0.2520	0.2441	0.2598
E1	4.400	4.300	4.500	0.1732	0.1693	0.1772
L	0.600	0.450	0.750	0.0236	0.0177	0.0295
L1	1.000			0.0394		
α		0°	8°		0°	8°

9 Part numbering

Table 17. Ordering information scheme

Example:	M34C02-W	-	W	MB	6	T	P
Device Type	M34 = ASSP I ² C serial access EEPROM						
Device Function	02 = 2 Kbit (256 x 8)						
Operating Voltage	W = V _{CC} = 2.5 to 5.5V (400kHz) L = V _{CC} = 2.2 to 5.5V (400kHz) R = V _{CC} = 1.8 to 5.5V (400kHz)						
Package	MB = UDFDFPN8 (MLP8) DW = TSSOP8 (169 mil width)						
Device Grade	6 = Industrial temperature range, -40 to 85 °C. Device tested with standard test flow 1 = Temperature range 0 to 70 °C. Device tested with standard test flow						
Option	blank = Standard Packing T = Tape and Reel Packing						
Plating Technology	P or G = ECOPACK® (RoHS compliant)						

For a list of available options (speed, package, etc.) or for further information on any aspect of this device, please contact your nearest ST Sales Office.

The category of second Level Interconnect is marked on the package and on the inner box label, in compliance with JEDEC Standard JESD97. The maximum ratings related to soldering conditions are also marked on the inner box label.

10 Revision history

Table 18. Document revision history

Date	Revision	Description of Revision
27-Dec-1999	2.0	Adjustments to the formatting. 0 to 70°C temperature range removed from DC and AC tables. No change to description of device, or parameters
07-Dec-2000	2.1	New definition of lead soldering temperature absolute rating for certain packages
13-Mar-2001	2.2	-R voltage range added
18-Jul-2002	2.3	TSSOP8 (3x3mm ² body size) package (MSOP8) added
22-May-2002	2.4	VDFPN8 package (MLP8) added
21-Jul-2003	3.0	Document reformatted. -F voltage range added.
17-Mar-2004	4.0	Table of Contents added. MLP package changed. Absolute Maximum Ratings for $V_{IO}(\text{min})$ and $V_{CC}(\text{min})$ changed. Soldering temperature information clarified for RoHS compliant devices. Device grade information clarified
14-Apr-2004	5.0	Typos corrected in Ordering Information example
26-Aug-2004	6.0	Device Grade clarified. Product List summary table added
30-Nov-2004	7.0	SO8 package removed.
14-Oct-2005	8.0	M34C02-R operating frequency upgraded to 400 kHz. Modified Section 1.1: Device Internal Reset , Figure 4: Maximum RP value versus bus parasitic capacitance (C) for an I²C Bus , Table 10: Input Parameters , I_{CC1} values in Table 11: DC Characteristics (M34C02-W) , Table 13: DC Characteristics (M34C02-R) , Table 15: DC Characteristics (M34C02-W-F) and moved M34C02-R to Table 14: AC Characteristics M34C02-W, M34C02-L, M34C02-R). Added Figure 3: Chip Enable input connection . Added EcoPack® and Ambient Operating Temperature information.
11-Apr-2006	9	BN and DS (PDIP and TSSOP8) packages removed. M34C02-F part number removed. Test Conditions modified for I_{CC1} and V_{OL} in Table 11: DC Characteristics (M34C02-W) . Device Internal Reset removed and replaced by Section 2.5: Supply voltage (VCC) . Blank option removed below Plating Technology in Table 17 .

Please Read Carefully:

Information in this document is provided solely in connection with ST products. STMicroelectronics NV and its subsidiaries ("ST") reserve the right to make changes, corrections, modifications or improvements, to this document, and the products and services described herein at any time, without notice.

All ST products are sold pursuant to ST's terms and conditions of sale.

Purchasers are solely responsible for the choice, selection and use of the ST products and services described herein, and ST assumes no liability whatsoever relating to the choice, selection or use of the ST products and services described herein.

No license, express or implied, by estoppel or otherwise, to any intellectual property rights is granted under this document. If any part of this document refers to any third party products or services it shall not be deemed a license grant by ST for the use of such third party products or services, or any intellectual property contained therein or considered as a warranty covering the use in any manner whatsoever of such third party products or services or any intellectual property contained therein.

UNLESS OTHERWISE SET FORTH IN ST'S TERMS AND CONDITIONS OF SALE ST DISCLAIMS ANY EXPRESS OR IMPLIED WARRANTY WITH RESPECT TO THE USE AND/OR SALE OF ST PRODUCTS INCLUDING WITHOUT LIMITATION IMPLIED WARRANTIES OF MERCHANTABILITY, FITNESS FOR A PARTICULAR PURPOSE (AND THEIR EQUIVALENTS UNDER THE LAWS OF ANY JURISDICTION), OR INFRINGEMENT OF ANY PATENT, COPYRIGHT OR OTHER INTELLECTUAL PROPERTY RIGHT.

UNLESS EXPRESSLY APPROVED IN WRITING BY AN AUTHORIZED REPRESENTATIVE OF ST, ST PRODUCTS ARE NOT DESIGNED, AUTHORIZED OR WARRANTED FOR USE IN MILITARY, AIR CRAFT, SPACE, LIFE SAVING, OR LIFE SUSTAINING APPLICATIONS, NOR IN PRODUCTS OR SYSTEMS, WHERE FAILURE OR MALFUNCTION MAY RESULT IN PERSONAL INJURY, DEATH, OR SEVERE PROPERTY OR ENVIRONMENTAL DAMAGE.

Resale of ST products with provisions different from the statements and/or technical features set forth in this document shall immediately void any warranty granted by ST for the ST product or service described herein and shall not create or extend in any manner whatsoever, any liability of ST.

ST and the ST logo are trademarks or registered trademarks of ST in various countries.

Information in this document supersedes and replaces all information previously supplied.

The ST logo is a registered trademark of STMicroelectronics. All other names are the property of their respective owners.

© 2006 STMicroelectronics - All rights reserved

STMicroelectronics group of companies

Australia - Belgium - Brazil - Canada - China - Czech Republic - Finland - France - Germany - Hong Kong - India - Israel - Italy - Japan - Malaysia - Malta - Morocco - Singapore - Spain - Sweden - Switzerland - United Kingdom - United States of America

www.st.com

