

FEATURES

- **PMBus™ Serial Interface for Programming and Telemetry**
- **Digital PID Control Loop**
- **Output Voltage Range: 0.7V to $V_{CC} - 0.9V$**
- Optional Resistor-Based PMBus Address, Output Voltage, Frequency and Current Limit Set
- 150kHz to 2MHz Switching Frequency
- DCR Current Sense with Temperature Compensation
- Adjustable Active Voltage Positioning (AVP) Control
- On-Chip Non-Volatile Memory (NVM) for Configuration Storage
- Soft-Start Into Pre-Biased Load
- Current Sharing
- 32-Lead (5mm × 5mm) QFN Package

APPLICATIONS

- Digital Power System Management
- Intelligent Point-of-Load (POL) Power Regulation

DESCRIPTION

The LTC[®]7510 is a digital DC/DC controller with onboard non-volatile memory and PMBus interface for real time reporting and control of point-of-load (POL) power management. Power supply sequencing, margining, turn-on/-off and fault detection are easily programmed via the PMBus interface.

The LTC7510 uses a digital control loop which eliminates external compensation components. The controller supports current sharing of multiple ICs; up to four controllers can be synchronized for multiphase operation.

The LTC7510 provides superior accuracy through internal calibration to correct current sense error sources upon start-up and programmable temperature compensation provides accurate current sensing over temperature. The LTC7510 is available in a 32-lead (5mm × 5mm) QFN package.

LT, LTC and LTM are registered trademarks of Linear Technology Corporation. All other trademarks are the property of their respective owners.

TYPICAL APPLICATION

DC/DC Controller with Read/Write PMBus Digital Interface

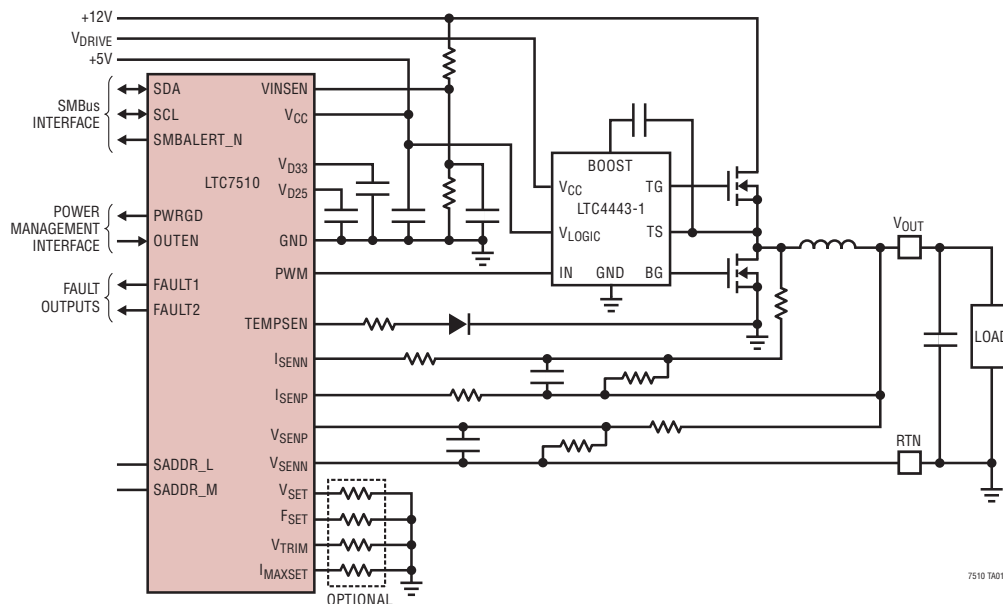

7510 TA01

LTC7510

ABSOLUTE MAXIMUM RATINGS

(Note 1)

Supply Voltage (V_{CC})	-0.3V to 6V
$V_{SEN\bar{P}}$, V_{SENN}	-0.3V to 3V
$I_{SEN\bar{P}}$, I_{SENN}	-0.3V to V_{CC}
OUTEN, SYNC_IN, SYNC_OUT, SMBALERT_N, PWRGD, PWM, SDA, SCL, FAULT1, FAULT2, SADDR_M	-0.3V to 6V
All Other Pins	-0.3V to 4.25V
Differential Voltage	
$V_{SEN\bar{D}IFF}$ ($V_{SEN\bar{P}} - V_{SENN}$)	-0.3V to 2.5V
Operating Temperature Range (Note 2)	-40°C to 85°C
Junction Temperature	125°C
Storage Temperature Range	-65°C to 150°C
Write Temperature	0°C to 85°C
Read Temperature	-40°C to 85°C

PIN CONFIGURATION

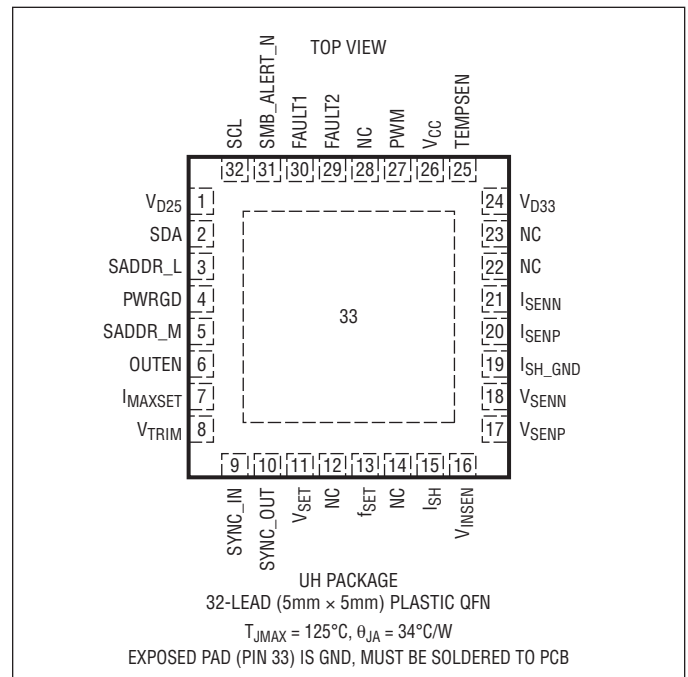

ORDER INFORMATION

LEAD FREE FINISH	TAPE AND REEL	PART MARKING*	PACKAGE DESCRIPTION	TEMPERATURE RANGE
LTC7510EUH#PBF	LTC7510EUH#TRPBF	7510	32-Lead (5mm x 5mm) Plastic QFN	-40°C to 85°C
LTC7510IUH#PBF	LTC7510IUH#TRPBF	7510	32-Lead (5mm x 5mm) Plastic QFN	-40°C to 85°C

Consult LTC Marketing for parts specified with wider operating temperature ranges. *The temperature grade is identified by a label on the shipping container. Consult LTC Marketing for information on non-standard lead based finish parts.

For more information on lead free part marking, go to: <http://www.linear.com/leadfree/>

For more information on tape and reel specifications, go to: <http://www.linear.com/tapeandreeel/>