

## LTC4359HDCB 12V/20A Ideal Diode with Reverse Input Protection

### DESCRIPTION

Demonstration circuit 1502A showcases the LTC®4359 ideal diode controller with reverse input protection. The board includes two independent LTC4359 ideal diode circuits, sharing a common ground and operating over a 4.5V to 28V range.

Each channel is capable of carrying 20A. Through-hole pads are included to permit modification for even higher currents, using an off board power stage.

**Design files for this circuit board are available at <http://www.linear.com/demo>**

LT, LT, LTC, LTM, Linear Technology and the Linear logo are registered trademarks of Linear Technology Corporation. All other trademarks are the property of their respective owners.

### PERFORMANCE SUMMARY Specifications are at T<sub>A</sub> = 25°C

PARAMETER	CONDITIONS	MIN	TYP	MAX	UNITS
Input Voltage Limits	Operating	4.5		28	V
	DC Survival	-40		90	V
	1ms Transient	-60		250	V
	VIN-VOUT	-60			V
Output Current Capability	4.5V ≤ VIN ≤ 8V			10	A
	VIN > 8V			20	A

## QUICK START PROCEDURE

### Overview

DC1502A features two independent LTC4359 ideal diode circuits sharing a common ground. Each channel handles up to 20A at room temperature, with no air flow. The board is double-sided. Reference designators are duplicated for the two sections of the board; the upper section is suffixed A while the lower section is suffixed B.

### Voltage Capability and Onboard Clamps

The voltage capability of DC1502A is clearly stated on the top side silkscreen and on the schematic. Several factors contribute to the listed ranges. First, there are the limits of the LTC4359 which has a specified operating range of 4V to 80V, and an absolute maximum rating for the IN,  $\overline{\text{SHDN}}$  and SOURCE pins of  $-40\text{V}$  to  $100\text{V}$ .

Second, there is the  $60\text{V}$   $\text{BV}_{\text{DSS}}$  rating of MOSFET Q1 that limits the VIN–VOUT rating of the board to  $-60\text{V}$  maximum. Higher excursions are made possible by operating Q1 in avalanche, or by replacing it with a higher voltage device.

Third, there are the clamp diodes D1 and D2. Clamping is necessary to rein in commutation spikes—the LTC4359 behavior is no different in this respect from ordinary rectifiers.

Fourth, there is the dissipation capability of R1, a component which has been chosen for its pulse capability. It becomes the limiting factor for DC conditions when the input voltage exceeds the breakdown of D1 or D2.

These factors combine to produce the INPUT VOLTAGE LIMITS table shown on the schematic and silkscreened on to the circuit board. Always bear in mind the VIN–VOUT limit of  $-60\text{V}$  which may further restrict the survival and transient limits.

### Current Capability

DC1502A is designed to carry 20A per channel, provided the LTC4359s are enabled. In the disabled state the associated Q1 MOSFET is turned off, and any forward current flows through the  $0.7\text{V}$  body diode. This limits the current

capability in the disabled state to  $\approx 1\text{A}$ . Do not attempt to pass 20A forward current in the disabled state, or Q1 will be destroyed.

The 10A and 20A current limitations in the enabled state result from MOSFET and board self heating, and from connector capability.

### Circuit Resistances

Typical  $R_{\text{DS(ON)}}$  for the BCS028N06NS MOSFET is  $2.5\text{m}\Omega$ , dropping  $50\text{mV}$  and dissipating about  $1\text{W}$  at  $20\text{A}$ . This produces a junction temperature rise of  $25^\circ\text{C}$  with the board lying on a bench top and deprived of air flow.

The circuit traces leading to and from Q1 and the interface between the board and the banana jacks amounts to  $500\mu\Omega$ , adding  $200\text{mW}$  dissipation at  $20\text{A}$ . The ground path measures about  $350\mu\Omega$ , which contributes an additional  $140\text{mW}$  dissipation. The total board+MOSFET dissipation for one channel driven is  $1.3\text{W}$  and with both channels driven, the total dissipation approaches  $3\text{W}$ . The ground copper loss may be eliminated by using a single power ground connection to DC1502A.

The best banana test leads (such as Pomona Model B banana plug) are rated to only  $10\text{A}$  to  $15\text{A}$ . For this reason, and to minimize self heating, all banana connections should be doubled up and kept as short as possible.

Banana plugs represent a substantial loss. Typical drop measured from the point where the wire exits a Pomona B-12 banana plug to the shoulder of the DC1502A banana jack is in excess of  $20\text{mV}$  at  $20\text{A}$ , or about  $1\text{m}\Omega$ . If each of the eight banana jacks is used to carry  $20\text{A}$ , they will add over  $3\text{W}$ , doubling the total dissipation.

If the turrets are removed,  $12\text{ AWG}$  bus wire can be installed in the vacated holes to virtually eliminate any voltage drop or dissipation associated with connections to the board. The dissipation is reduced to about  $20\text{mW}$  ( $50\mu\Omega$ ) per connection. Use the banana jacks for Kelvin meter connections.

## QUICK START PROCEDURE

At 20A even 12 AWG wire has its limitations: the resistance is  $\approx 1.6\text{m}\Omega/\text{foot}$ ; one foot dissipates a surprising 640mW at 20A. Some of this heat is conducted into the circuit board.

Another means of making connections is to attach ring terminals or copper terminal lugs to the banana jacks, using 8-32 screws. A Blackburn/Thomas&Betts BTC1014 terminal lug, enlarged for a number eight screw with a #15 drill, accepts up to 10 AWG stranded wire; BTC0614 accepts up to 6 AWG wire and needs no machining.

Various typical circuit resistances are summarized in the Various Voltage Drops Measured at 10A Load Current table.

### Modifying for Higher Current

The resistance issues discussed in the previous section make obvious that modification of the demo board itself for higher current is futile. Nevertheless, an off board power stage may be constructed and connected to DC1502A by using the SOURCE, DRAIN and GATE test pads. Snub the MOSFET with a  $100\Omega$ , 10nF series network directly across the device's drain and source terminals. Do not pass load current through the DC1502A ground terminals.

### Modifying for Other Applications

Pads are provided so that the board may be modified to match any of the data sheet diode applications. Components used in other applications include D3, D5 and D6, all located on the bottom of the board.  $R_{\text{SNUB}}$  and  $C_{\text{SNUB}}$  are useful for certain MOSFETs that exhibit parasitic stability issues, such as the FDMS86101.

### Shutdown

The LTC4359 may be shut down by moving the  $\overline{\text{SHDN}}$  jumper to the OFF position, which pulls  $\overline{\text{SHDN}}$  to VSS through  $100\text{k}\Omega$  (R5). Shutdown reduces the quiescent current to  $\approx 14\mu\text{A}$ . In the ON position the  $\overline{\text{SHDN}}$  pin floats; an internal  $2\mu\text{A}$  pull up asserts it high, enabling the LTC4359. In the EXT position, the  $\overline{\text{SHDN}}$  pin is connected through R5 to the  $\overline{\text{SHDN}}$  turret. If the  $\overline{\text{SHDN}}$  turret is left open, the

LTC4359 is enabled. To disable, connect the  $\overline{\text{SHDN}}$  turret to the neighboring VSS turret.  $\overline{\text{SHDN}}$  pin level shift circuits are shown in data sheet Figure 3.

Because the  $\overline{\text{SHDN}}$  pin is high impedance, it is subject to capacitive coupling. A 10nF noise bypass capacitor, CF, works with R5 to keep noise out of the  $\overline{\text{SHDN}}$  pin. R5 also helps protect the  $\overline{\text{SHDN}}$  pin against inadvertent overvoltage conditions that might arise from use of the  $\overline{\text{SHDN}}$  turret.

It is important to note that shutting down the LTC4359 does not interrupt the forward current path. Even when the LTC4359 is in the shutdown state and Q1 is off, Q1's body diode is still present and will conduct forward current. Do not shut down the LTC4359 when the MOSFET is carrying a forward current of more than 1A. High dissipation will result in rapid destruction of Q1.

### How to Operate DC1502A

A simple demonstration of DC1502A's operation is as follows (see Figure 1). Connect two adjustable power supplies, each set to 12V. Connect one to VIN A and nearby GND, the second to VIN B and its associated GND. Place the  $\overline{\text{SHDN}}$  jumpers in the ON position. Join the outputs of VOUT A and VOUT B together at the input of a DC load of up to 20A. Slowly adjust one power supply up and down relative to the other while monitoring the power supply currents. The higher supply will carry the load current, with a narrow transition region where the voltages are nearly identical and the supplies droop share. If one supply is shorted, the output voltage will not collapse—the other supply will carry the load.

The forward characteristics of the LTC4359 can be tested without using a high power load and using only a low voltage 20A supply, as shown in Figure 2. First, DC1502A is biased with a 12V supply. This supply provides quiescent current for the two channels, totaling less than 1mA. Second, connect the two channels in series (VOUT A connected to VIN B), and connect a 20A, current-limited low voltage ( $\approx 1\text{V}$ ) supply to VIN A and VOUT B.

# DEMO MANUAL DC1502A

## QUICK START PROCEDURE

Turn on the 12V bias supply first, and then turn on the 20A supply. 20A will flow from the input of channel A, through Q1A, to the input of channel B, through Q1B, and back out to the 20A power supply. This arrangement eliminates the need for high power supplies, eliminates the need for a second high current supply and eliminates the need for a high power load, yet the forward behavior of the LTC4359 and the board, connector and MOSFET voltage drops are readily examined as though the board was fully loaded with each channel carrying 20A. Always remember that the 12V supply must be present whenever forward current is flowing.

The 20A supply may be adjusted from zero to 20A and the 12V supply may be adjusted from 8.5V to 28V, to observe operation under any operating condition. At 10A, the 12V supply may be adjusted to as low as 4.5V.

When powering down, turn off the 20A supply first and then turn off the 12V supply. Using this sequence precludes passing 20A through the body diodes of Q1A and Q1B.

Various Voltage Drops Measured at 10A Load Current

PATH	MEASURED VOLTAGE DROP AT 10A	COMPUTED RESISTANCE	COMPUTED DISSIPATION AT 20A
Banana Tip to Banana Jack Shoulder (Input)	5.6mV	560μΩ	224mW
Banana Jack Shoulder to SOURCE Pad	0.6mV	60μΩ	
Banana Jack Shoulder to Center Source Lead	2.6mV	260μΩ	104mW
Center Source Lead to Drain Lead	28.1mV	2.81mΩ	1.12W
Drain Lead to Banana Jack Shoulder	1.8mV	180μΩ	72mW
Banana Jack Shoulder to Banana Lead Tip (Output)	2.8mV	280μΩ	112mW
SOURCE Pad to DRAIN Pad	31.4mV	3.14mΩ	
LTC4359 IN to OUT Pins	30.5mV	3.05mΩ	
Shoulder to Shoulder (Total Board Drop)	32.7mV	3.27mΩ	1.31W

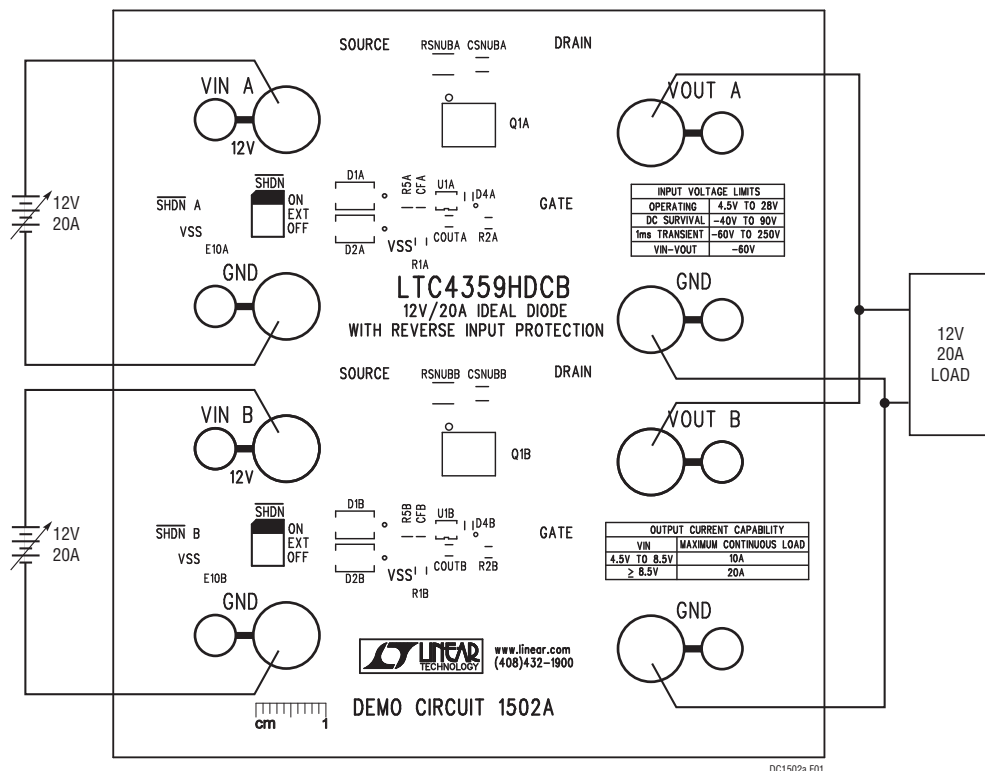

Figure 1. Basic Operation of DC1502A

QUICK START PROCEDURE

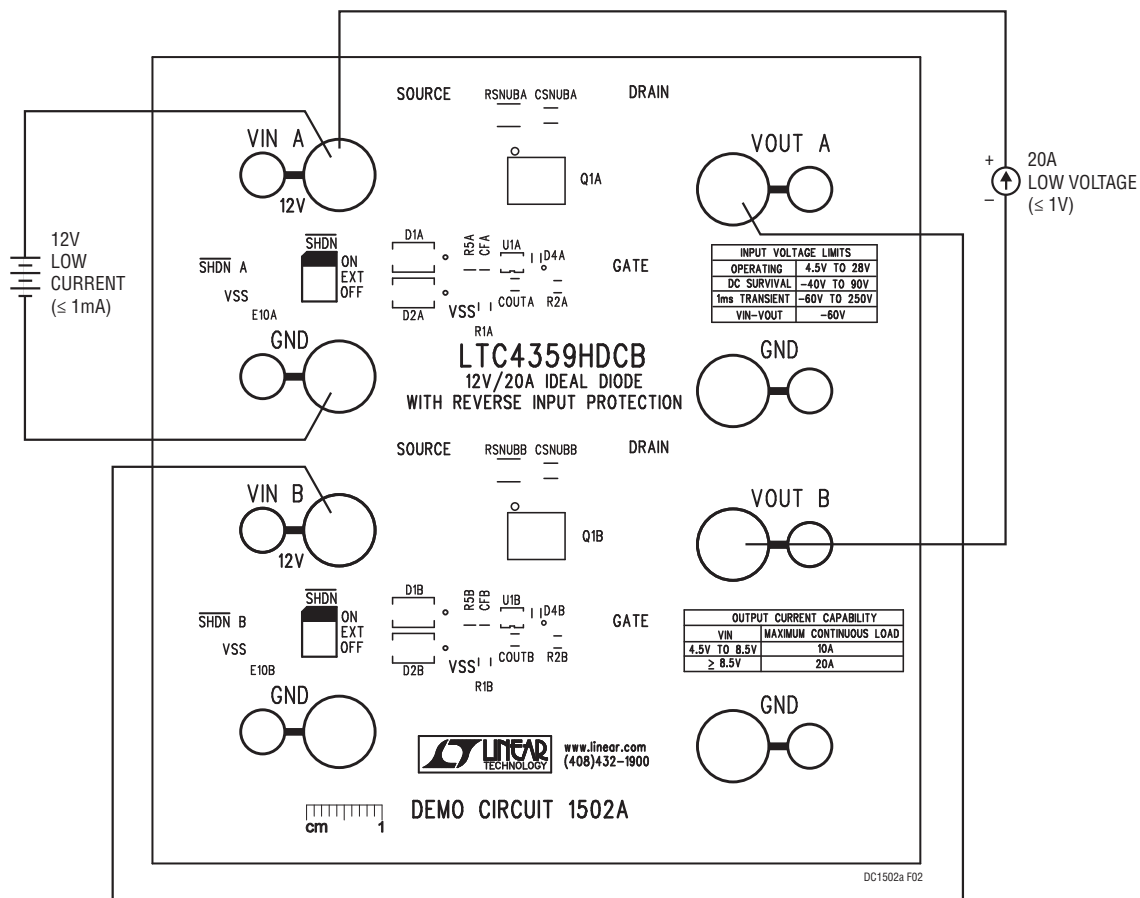

Figure 2. Testing Voltage Drops at High Current without the Need for High Power Supplies

# DEMO MANUAL DC1502A

## PARTS LIST

ITEM	QTY	REFERENCE	PART DESCRIPTION	MANUFACTURER/PART NUMBER
<b>Required Circuit Components</b>				
1	2	CFB, CFA	CAP, X7R, 10nF, 100V 20% 0805	AVX, 08051C103MAT2A
2	2	COU7B, COU7A	CAP, X7R, 47nF, 200V 20% 1206	AVX, 12062C473MAT2A
3	0	CSNUBB, CSNUBA	CAP, X7R, 10nF, 500V 20% 1206, OPTION	AVX, 12067C103MAT2A
4	2	D1B, D1A	DIODE, TVS, 70V, SMA	DIODES INC/ZETEX, SMAT70A-13-F
5	2	D2B, D2A	DIODE, TVS, 24V, SMA	DIODES INC/ZETEX, SMAJ24A-13-F
6	0	D3B, D3A, D6B, D6A	DIODE, TVS, 70V, SMA, OPTION	DIODES INC/ZETEX, SMAT70A-13-F
7	2	D4B, D4A	DIODE, ZENER 12V 150mW SOD-523	DIODES INC/ZETEX, DDZ9699T-7
8	0	D5B, D5A	DIODE, SWITCHING, 300V, SOD-123, OPTION	DIODES INC/ZETEX, BAV3004W-7-F
9	8	E1B, E1A, E4B, E4A, E6B, E6A, E8B, E8A	BANANA JACK, NON-INSULATED	KEYSTONE, 575-4
10	8	E2B, E2A, E5B, E5A, E7B, E7A, E9B, E9A	TEST POINT, TURRET, 0.094, PBF	MILL-MAX, 2501-2-00-80-00-00-07-0
11	4	E3B, E3A, E10B, E10A	TEST POINT, TURRET, 0.061, PBF	MILL-MAX, 2308-2-00-80-00-00-07-0
12	2	JP1B, JP1A	HEADER, 2X3 PIN, 0.079CC	SAMTEC, TMM-103-02-L-D
13	6	MH1 TO MH6	STANDOFF, NYLON 0.5"	KEYSTONE, 8833 (SNAP ON)
14	2	Q1B, Q1A	TRANSISTOR, POWER MOSFET, N-CH 60V, 100A TDSON-8	INFINEON, BSC028N06NS
15	0	RSNUBB, RSNUBA	RES, CHIP, 100Ω, 1/2W, 5%, 1210, OPT	NIC, NRCP25J101TRF
16	2	R1B, R1A	RES, CHIP, HIGH POWER, 1k, 1/2W, 5% 1206	VISHAY, CRCW12061K00JNEAHP
17	2	R2B, R2A	RES, CHIP, HIGH POWER, 0Ω, 1/2W, 5% 1206	VISHAY, CRCW12060000Z0EAHP
			R2 PART OPTION 2k, 1/2W 5% 1206	VISHAY, CRCW12062K00FKEAHP
18	2	R5B, R5A	RES, CHIP, 100k, 1/8W, 5% 0805	VISHAY, CRCW0805100KJNEA
19	2	U1B, U1A	IC, 28V IDEAL DIODE, DFN-6L	LINEAR TECHNOLOGY, LTC4359HDCB#PBF
20	2	XJP1B, XJP1A	SHUNT, 2MM	SAMTEC, 2SN-BK-G

## SCHEMATIC DIAGRAM

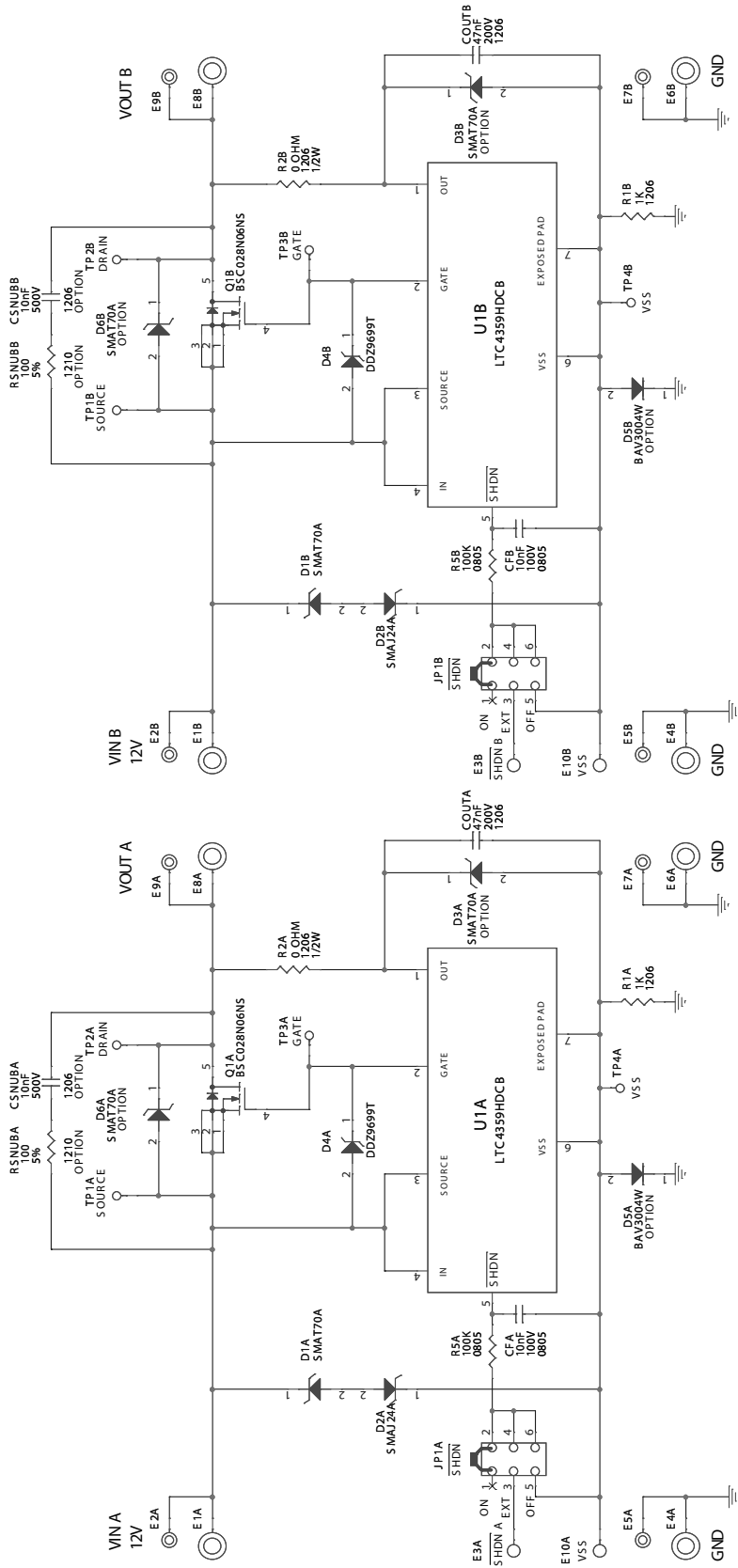

NOTE: LTC4359HDCB TOP MARK LFKF

OUTPUT CURRENT CAPABILITY	
VIN	MAXIMUM CONTINUOUS LOAD
4.5V TO 8V	10A
≥8V	20A

INPUT VOLTAGE LIMITS	
OPERATING	4.5V TO 28V
DC SURVIVAL	-40V TO 90V
1ms TRANSIENT	-60V TO 250V
VIN - VOUT	-60V

- MH1   MH2   MH3   MH4   MH5   MH6
- ○   ○   ○   ○   ○
- SNAP-IN STANDOFFS ON PC BOARD

# DEMO MANUAL DC1502A

---

## DEMONSTRATION BOARD IMPORTANT NOTICE

Linear Technology Corporation (LTC) provides the enclosed product(s) under the following **AS IS** conditions:

This demonstration board (DEMO BOARD) kit being sold or provided by Linear Technology is intended for use for **ENGINEERING DEVELOPMENT OR EVALUATION PURPOSES ONLY** and is not provided by LTC for commercial use. As such, the DEMO BOARD herein may not be complete in terms of required design-, marketing-, and/or manufacturing-related protective considerations, including but not limited to product safety measures typically found in finished commercial goods. As a prototype, this product does not fall within the scope of the European Union directive on electromagnetic compatibility and therefore may or may not meet the technical requirements of the directive, or other regulations.

If this evaluation kit does not meet the specifications recited in the DEMO BOARD manual the kit may be returned within 30 days from the date of delivery for a full refund. **THE FOREGOING WARRANTY IS THE EXCLUSIVE WARRANTY MADE BY THE SELLER TO BUYER AND IS IN LIEU OF ALL OTHER WARRANTIES, EXPRESSED, IMPLIED, OR STATUTORY, INCLUDING ANY WARRANTY OF MERCHANTABILITY OR FITNESS FOR ANY PARTICULAR PURPOSE. EXCEPT TO THE EXTENT OF THIS INDEMNITY, NEITHER PARTY SHALL BE LIABLE TO THE OTHER FOR ANY INDIRECT, SPECIAL, INCIDENTAL, OR CONSEQUENTIAL DAMAGES.**

The user assumes all responsibility and liability for proper and safe handling of the goods. Further, the user releases LTC from all claims arising from the handling or use of the goods. Due to the open construction of the product, it is the user's responsibility to take any and all appropriate precautions with regard to electrostatic discharge. Also be aware that the products herein may not be regulatory compliant or agency certified (FCC, UL, CE, etc.).

No License is granted under any patent right or other intellectual property whatsoever. **LTC assumes no liability for applications assistance, customer product design, software performance, or infringement of patents or any other intellectual property rights of any kind.**

LTC currently services a variety of customers for products around the world, and therefore this transaction **is not exclusive**.

**Please read the DEMO BOARD manual prior to handling the product.** Persons handling this product must have electronics training and observe good laboratory practice standards. **Common sense is encouraged.**

This notice contains important safety information about temperatures and voltages. For further safety concerns, please contact a LTC application engineer.

Mailing Address:

Linear Technology  
1630 McCarthy Blvd.  
Milpitas, CA 95035

Copyright © 2004, Linear Technology Corporation