

FEATURES

- Reduces Power Dissipation by Replacing a Power Schottky Diode with an N-Channel MOSFET
- 0.5 μ s Turn-Off Time Limits Peak Fault Current
- Wide Operating Voltage Range: 9V to 80V
- Smooth Switchover without Oscillation
- No Reverse DC Current
- Available in 6-Lead (2mm \times 3mm) DFN and 8-Lead MSOP Packages

APPLICATIONS

- N + 1 Redundant Power Supplies
- High Availability Systems
- AdvancedTCA Systems
- Telecom Infrastructure
- Automotive Systems

DESCRIPTION

The LTC[®]4357 is a positive high voltage ideal diode controller that drives an external N-channel MOSFET to replace a Schottky diode. When used in diode-OR and high current diode applications, the LTC4357 reduces power consumption, heat dissipation, voltage loss and PC board area.

The LTC4357 easily ORs power sources to increase total system reliability. In diode-OR applications, the LTC4357 controls the forward voltage drop across the MOSFET to ensure smooth current transfer from one path to the other without oscillation. If the power source fails or is shorted, a fast turn-off minimizes reverse current transients.

LT, LT, LTC and LTM are registered trademarks of Linear Technology Corporation. All other trademarks are the property of their respective owners.

TYPICAL APPLICATION

48V, 10A Diode-OR

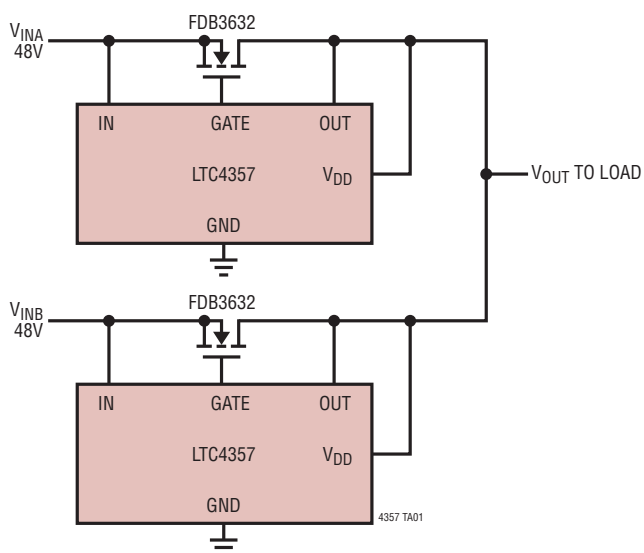

Power Dissipation vs Load Current

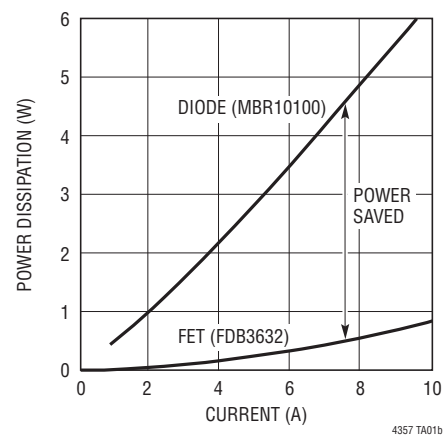

LTC4357

ABSOLUTE MAXIMUM RATINGS (Notes 1, 2)

Supply Voltages IN, OUT, V _{DD}	-0.3V to 100V	Storage Temperature Range DCB Package	-65°C to 150°C
Output Voltage GATE (Note 3)	V _{IN} - 0.2V to V _{IN} + 10V	MS Package	-65°C to 150°C
Operating Ambient Temperature Range LTC4357C	0°C to 70°C	Lead Temperature (Soldering, 10 sec) MS Package	300°C
LTC4357I	-40°C to 85°C		

PIN CONFIGURATION

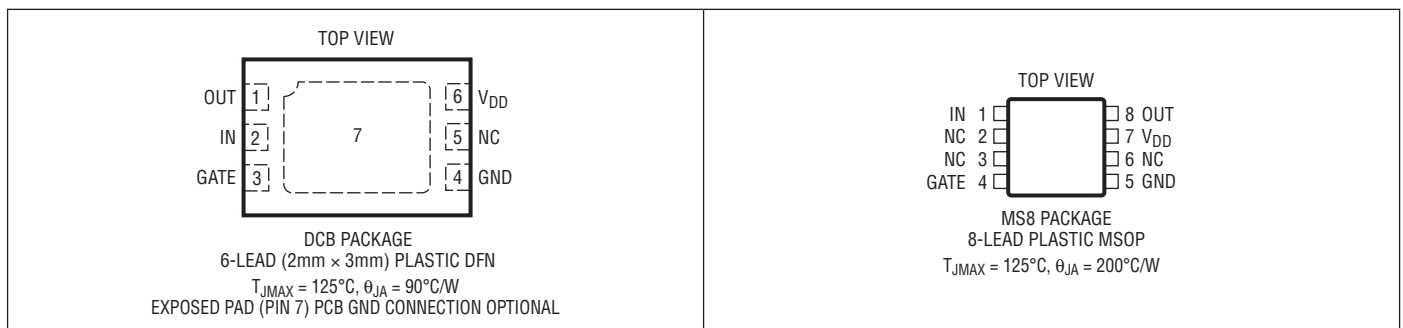

ORDER INFORMATION

LEAD FREE FINISH	TAPE AND REEL	PART MARKING*	PACKAGE DESCRIPTION	TEMPERATURE RANGE
LTC4357CDCB#TRMPBF	LTC4357CDCB#TRPBF	LCXF	6-Lead (2mm × 3mm) Plastic DFN	0°C to 70°C
LTC4357IDCB#TRMPBF	LTC4357IDCB#TRPBF	LCXF	6-Lead (2mm × 3mm) Plastic DFN	-40°C to 85°C
LTC4357CMS8#PBF	LTC4357CMS8#TRPBF	LTCXD	8-Lead Plastic MSOP	0°C to 70°C
LTC4357IMS8#PBF	LTC4357IMS8#TRPBF	LTCXD	8-Lead Plastic MSOP	-40°C to 85°C

Consult LTC Marketing for parts specified with wider operating temperature ranges. *The temperature grade is identified by a label on the shipping container. Consult LTC Marketing for information on non-standard lead based finish parts.

For more information on lead free part marking, go to: <http://www.linear.com/leadfree/>

For more information on tape and reel specifications, go to: <http://www.linear.com/tapeandreeel/>

ELECTRICAL CHARACTERISTICS

The ● denotes the specifications which apply over the full operating temperature range, otherwise specifications are at T_A = 25°C. V_{OUT} = V_{DD}, V_{DD} = 9V to 80V unless otherwise noted.

SYMBOL	PARAMETER	CONDITIONS	MIN	TYP	MAX	UNITS
V _{DD}	Operating Supply Range		● 9		80	V
I _{DD}	Supply Current		●	0.5	1	mA
I _{IN}	IN Pin Current	V _{IN} = V _{OUT} ± 1V	● 150	350	450	μA
I _{OUT}	OUT Pin Current	V _{IN} = V _{OUT} ± 1V	●	80	170	μA
ΔV _{GATE}	External N-Channel Gate Drive (V _{GATE} - V _{IN})	V _{DD} , V _{OUT} = 20V to 80V V _{DD} , V _{OUT} = 9V to 20V	● 10 4.5	12 6	15 15	V V

4357fb

ELECTRICAL CHARACTERISTICS

The ● denotes the specifications which apply over the full operating temperature range, otherwise specifications are at $T_A = 25^\circ\text{C}$. $V_{OUT} = V_{DD}$, $V_{DD} = 9\text{V to } 80\text{V}$ unless otherwise noted.

SYMBOL	PARAMETER	CONDITIONS		MIN	TYP	MAX	UNITS
$I_{GATE(UP)}$	External N-Channel Gate Pull Up Current	$V_{GATE} = V_{IN}$, $V_{IN} - V_{OUT} = 0.1\text{V}$	●	-14	-20	-26	μA
$I_{GATE(DOWN)}$	External N-Channel Gate Pull Down Current in Fault Condition	$V_{GATE} = V_{IN} + 5\text{V}$	●	1	2		A
t_{OFF}	Gate Turn-Off Time	$V_{IN} - V_{OUT} = 55\text{mV}$ $\left[-1\text{V}, V_{GATE} - V_{IN} < 1\text{V} \right]$	●		300	500	ns
ΔV_{SD}	Source-Drain Regulation Voltage ($V_{IN} - V_{OUT}$)	$V_{GATE} - V_{IN} = 2.5\text{V}$	●	10	25	55	mV

Note 1: Stresses beyond those listed under Absolute Maximum Ratings may cause permanent damage to the device. Exposure to any Absolute Maximum Rating condition for extended periods may affect device reliability and lifetime.

Note 2: All currents into pins are positive, all voltages are referenced to GND unless otherwise specified.

Note 3: An internal clamp limits the GATE pin to a minimum of 10V above IN or 100V above GND. Driving this pin to voltages beyond this clamp may damage the device.

TYPICAL PERFORMANCE CHARACTERISTICS

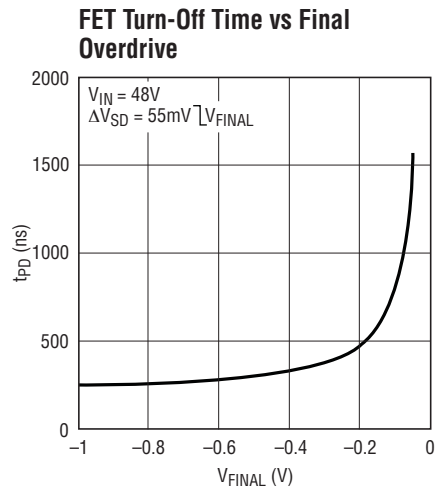
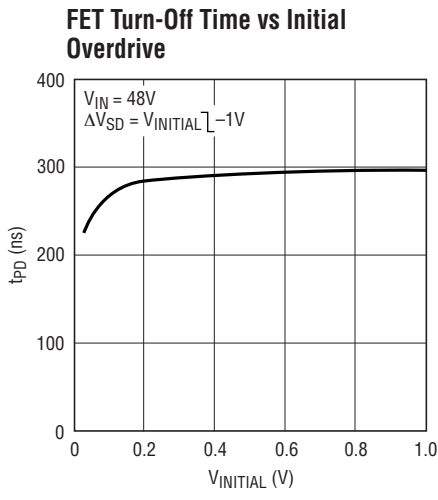
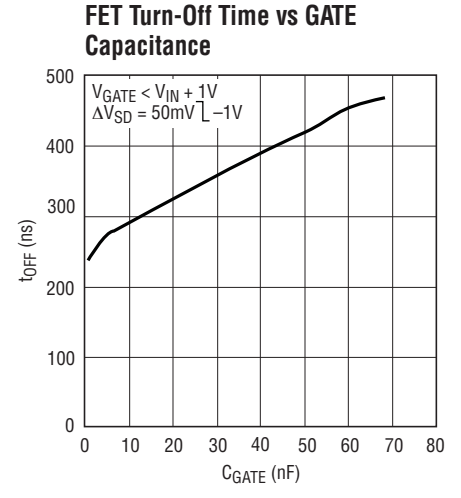
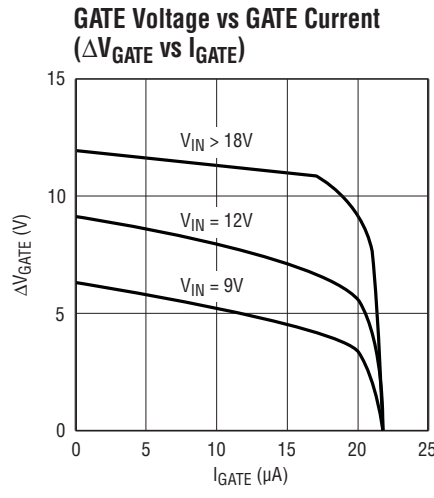
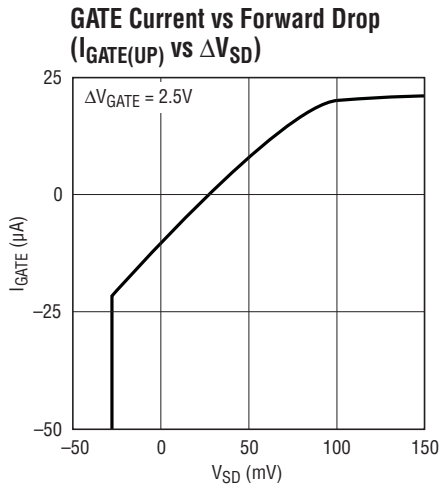
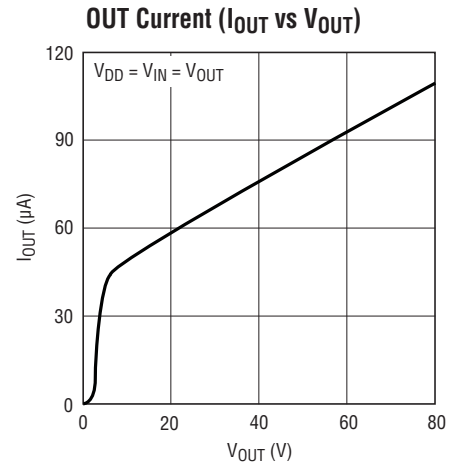
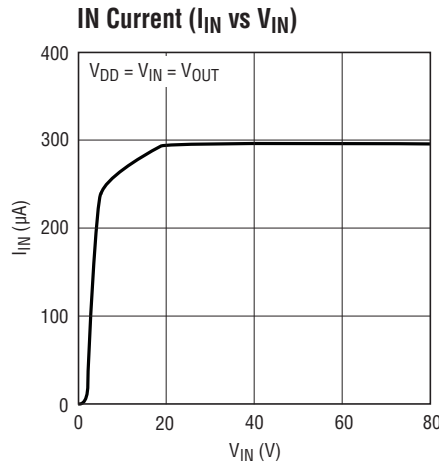
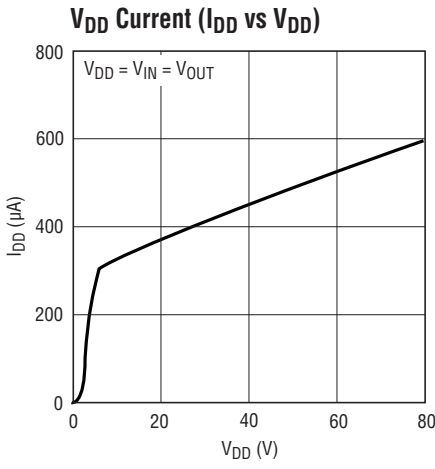

PIN FUNCTIONS

Exposed Pad: Exposed Pad may be left open or connected to GND.

GATE: Gate Drive Output. The GATE pin pulls high, enhancing the N-channel MOSFET when the load current creates more than 25mV of voltage drop across the MOSFET. When the load current is small, the gate is actively driven to maintain 25mV across the MOSFET. If reverse current develops more than -25mV of voltage drop across the MOSFET, a fast pulldown circuit quickly connects the GATE pin to the IN pin, turning off the MOSFET.

GND: Device Ground.

IN: Input Voltage and GATE Fast Pull-Down Return. IN is the anode of the ideal diode and connects to the source of the N-channel MOSFET. The voltage sensed at this pin

is used to control the source-drain voltage across the MOSFET. The GATE fast pulldown current is returned through the IN pin. Connect this pin as close as possible to the MOSFET source.

NC: No Connection. Not internally connected.

OUT: Drain Voltage Sense. OUT is the cathode of the ideal diode and the common output when multiple LTC4357s are configured as an ideal diode-OR. It connects to the drain of the N-channel MOSFET. The voltage sensed at this pin is used to control the source-drain voltage across the MOSFET.

V_{DD}: Positive Supply Input. The LTC4357 is powered from the V_{DD} pin. Connect this pin to OUT either directly or through an RC hold-up circuit.

BLOCK DIAGRAM

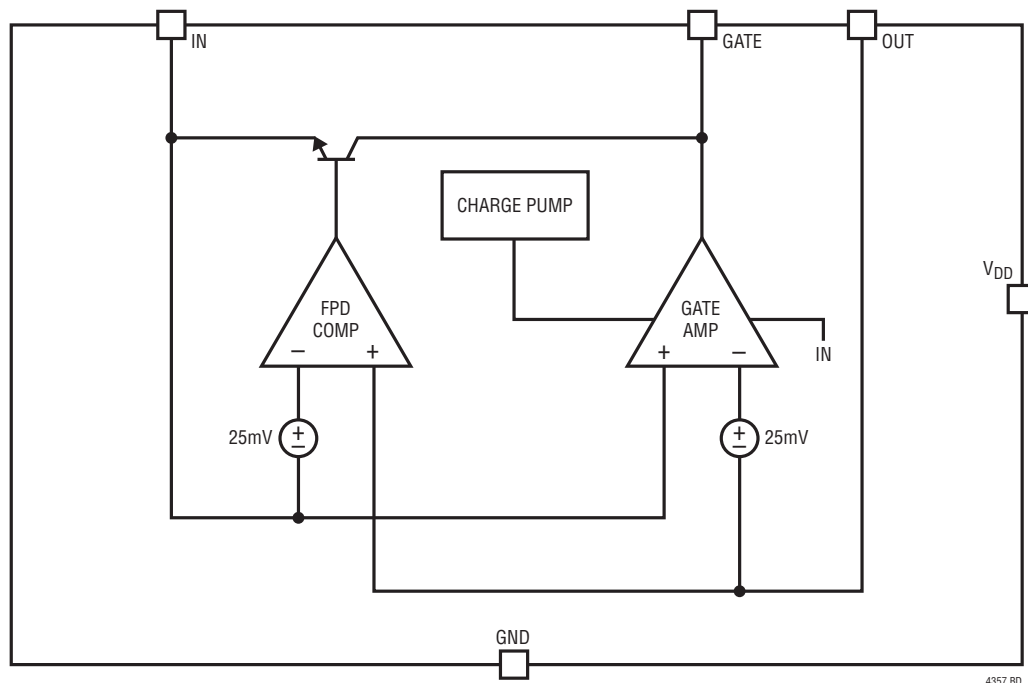

OPERATION

High availability systems often employ parallel-connected power supplies or battery feeds to achieve redundancy and enhance system reliability. ORing diodes have been a popular means of connecting these supplies at the point of load. The disadvantage of this approach is the forward voltage drop and resulting efficiency loss. This drop reduces the available supply voltage and dissipates significant power. Using an N-channel MOSFET to replace a Schottky diode reduces the power dissipation and eliminates the need for costly heat sinks or large thermal layouts in high power applications.

The LTC4357 controls an external N-channel MOSFET to form an ideal diode. The voltage across the source and drain is monitored by the IN and OUT pins, and the GATE pin drives the MOSFET to control its operation. In effect the MOSFET source and drain serve as the anode and cathode of an ideal diode.

At power-up, the load current initially flows through the body diode of the MOSFET. The resulting high forward

voltage is detected at the IN and OUT pins, and the LTC4357 drives the GATE pin to servo the forward drop to 25mV. If the load current causes more than 25mV of voltage drop when the MOSFET gate is driven fully on, the forward voltage is equal to $R_{DS(ON)} \cdot I_{LOAD}$.

If the load current is reduced causing the forward drop to fall below 25mV, the MOSFET gate is driven lower by a weak pull-down in an attempt to maintain the drop at 25mV. If the load current reverses and the voltage across IN to OUT is more negative than -25mV the LTC4357 responds by pulling the MOSFET gate low with a strong pull-down.

In the event of a power supply failure, such as if the output of a fully loaded supply is suddenly shorted to ground, reverse current temporarily flows through the MOSFET that is on. This current is sourced from any load capacitance and from the other supplies. The LTC4357 quickly responds to this condition turning off the MOSFET in about 500ns, thus minimizing the disturbance to the output bus.

APPLICATIONS INFORMATION

MOSFET Selection

The LTC4357 drives an N-channel MOSFET to conduct the load current. The important features of the MOSFET are on-resistance, $R_{DS(ON)}$, the maximum drain-source voltage, V_{DSS} , and the gate threshold voltage.

Gate drive is compatible with 4.5V logic-level MOSFETs in low voltage applications ($V_{DD} = 9V$ to $20V$). At higher voltages ($V_{DD} = 20V$ to $80V$) standard 10V threshold MOSFETs may be used. An internal clamp limits the gate drive to 15V between the GATE and IN pins. An external zener clamp may be added between GATE and IN for MOSFETs with a $V_{GS(MAX)}$ of less than 15V.

The maximum allowable drain-source voltage, BV_{DSS} , must be higher than the power supply voltage. If an input is connected to GND, the full supply voltage will appear across the MOSFET.

ORing Two Supply Outputs

Where LTC4357s are used to combine the outputs of two power supplies, the supply with the highest output voltage sources most or all of the load current. If this supply's output is quickly shorted to ground while delivering load current, the flow of current temporarily reverses and flows backwards through the LTC4357's MOSFET. When the reverse current produces a voltage drop across the MOSFET of more than $-25mV$, the LTC4357's fast pull-down activates and quickly turns off the MOSFET.

If the other, initially lower, supply was not delivering load current at the time of the fault, the output falls until the body diode of its ORing MOSFET conducts. Meanwhile, the LTC4357 charges its MOSFET gate with $20\mu A$ until the forward drop is reduced to $25mV$. If instead this supply was delivering load current at the time of the fault, its associated ORing MOSFET was already driven at least partially on, and the LTC4357 will simply drive the MOSFET gate harder in an effort to maintain a drop of $25mV$.

When the capacitances at the input and output are very small, rapid changes in current can cause transients that exceed the 100V Absolute Maximum Rating of the IN, OUT, and V_{DD} pins. A surge suppressor (TransZorb or TVS) connected from OUT to ground clamps the output and prevents

damage by limiting the magnitude of the peak voltage. In the absence of a surge suppressor, an output capacitance of $10\mu F$ is sufficient in most applications to prevent the transient from exceeding 100V. In lower voltage applications, the MOSFET's drain-source breakdown voltage may be sufficient to protect the LTC4357 provided $BV_{DSS} + V_{IN} < 100V$, making a surge suppressor unnecessary.

Load Sharing

The application in Figure 1 combines the outputs of multiple, redundant supplies using a simple technique known as droop sharing. Load current is first taken from the highest output, with the low outputs contributing as the output voltage falls under increased loading. The $25mV$ regulation technique ensures smooth load sharing between outputs without oscillation. The degree of sharing is a function of $R_{DS(ON)}$, the output impedance of the supplies and their initial output voltages.

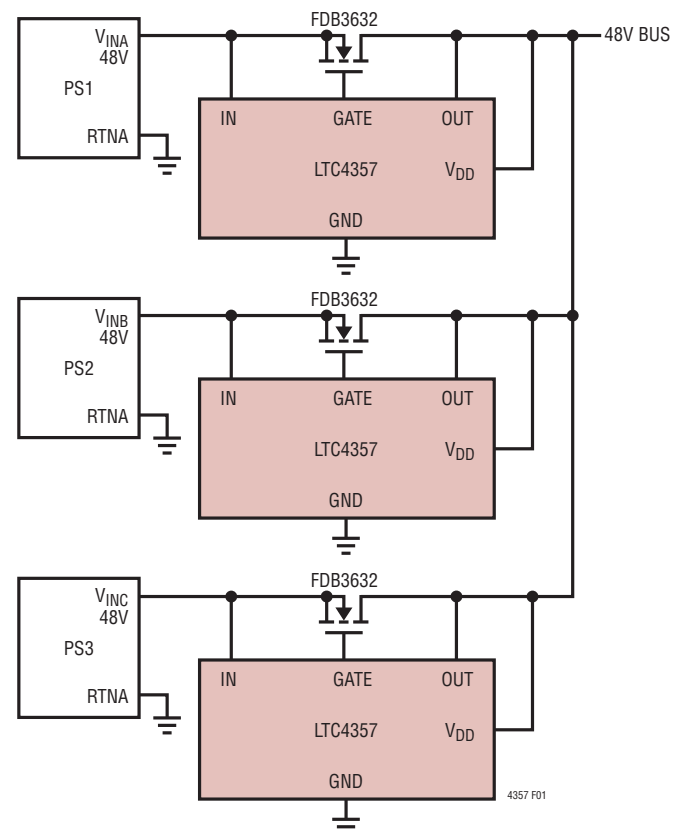

Figure 1. Droop Sharing Redundant Supplies

APPLICATIONS INFORMATION

V_{DD} Hold-Up Circuit

In the event of an input short, parasitic inductance between the input supply of the LTC4357 and the load bypass capacitor may cause V_{DD} to glitch below its minimum operating voltage. This causes the turn-off time (t_{OFF}) to increase.

To preserve the fast turn-off time, local output bypassing of 39μF is sufficient at voltages less than 30V. At higher voltages, 100μF is adequate. As an alternative to local bypassing, a 100Ω, 0.1μF RC hold-up circuit on the V_{DD} pin can be used, shown in Figure 2. In applications with unusually large inductance or load current greater than 10A, use 100Ω and 1μF.

Design Example

The following design example demonstrates the calculations involved for selecting components in a 12V system with 10A maximum load current (see Figure 3).

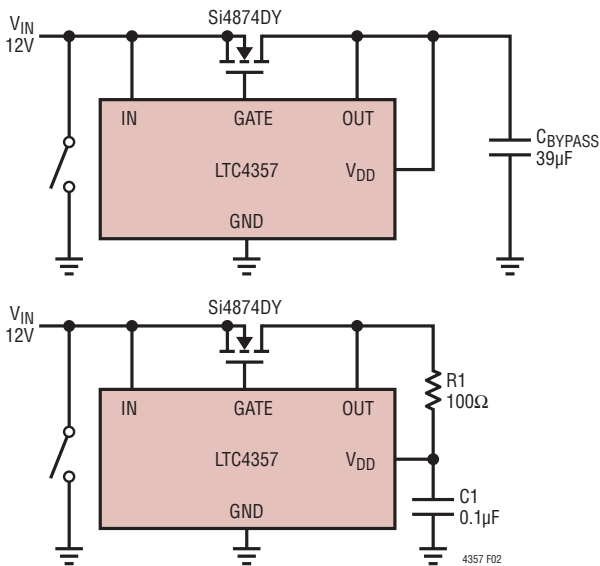

Figure 2. Two Methods of Protecting Against Collapse of V_{DD} From Input Short and Stray Inductance

First, calculate the R_{DS(ON)} of the MOSFET to achieve the desired forward drop at full load. Assuming V_{DROP} = 0.1V,

$$R_{DS(ON)} \leq \frac{V_{DROP}}{I_{LOAD}} = \frac{0.1V}{10A}$$

$$R_{DS(ON)} \leq 10m\Omega$$

The Si4874DY offers a good solution, in an S8 package with R_{DS(ON)} = 10mΩ(max) and BV_{DSS} of 30V.

The maximum power dissipation in the MOSFET is:

$$P = I_{LOAD}^2 \cdot R_{DS(ON)} = (10A)^2 \cdot 10m\Omega = 1W$$

With less than 39μF of local bypass, the recommended RC values of 100Ω and 0.1μF were used in Figure 3.

Since BV_{DSS} + V_{IN} is much less than 100V, output clamping is unnecessary.

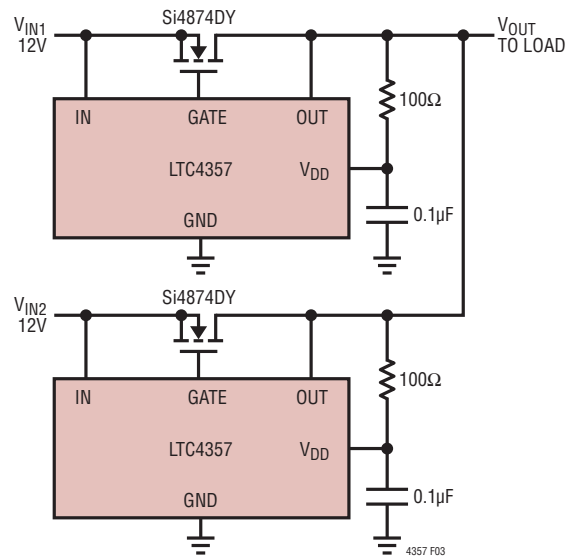

Figure 3. 12V, 10A Diode-OR

APPLICATIONS INFORMATION

Layout Considerations

Connect the IN and OUT pins as close as possible to the MOSFET's source and drain pins. Keep the traces to the MOSFET wide and short to minimize resistive losses. See Figure 4.

For the DFN package, pin spacing may be a concern at voltages greater than 30V. Check creepage and clearance guidelines to determine if this is an issue. To increase the pin spacing between high voltage and ground pins, leave the exposed pad connection open. Use no-clean solder to minimize PCB contamination.

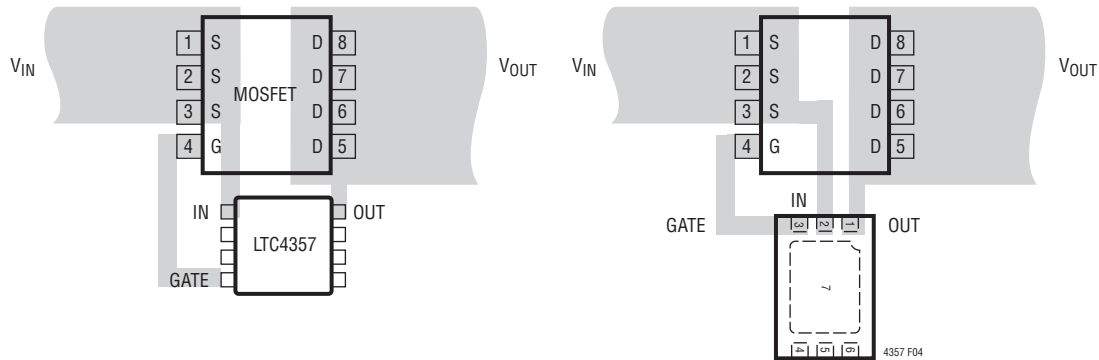
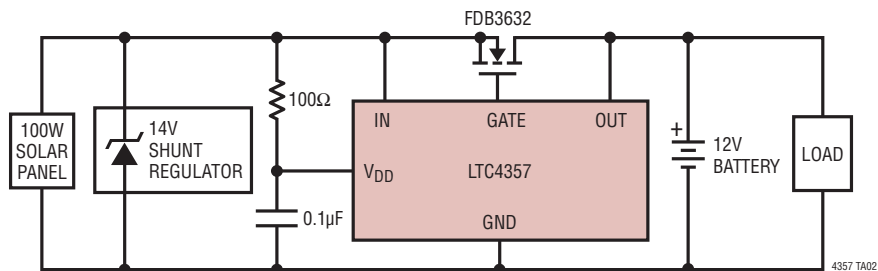

Figure 4. Layout Considerations

TYPICAL APPLICATIONS

Solar Panel Charging a Battery



TYPICAL APPLICATIONS

-12V Reverse Input Protection

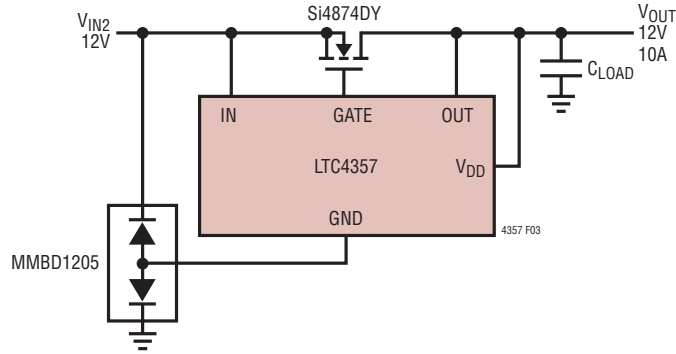

-48V Reverse Input Protection

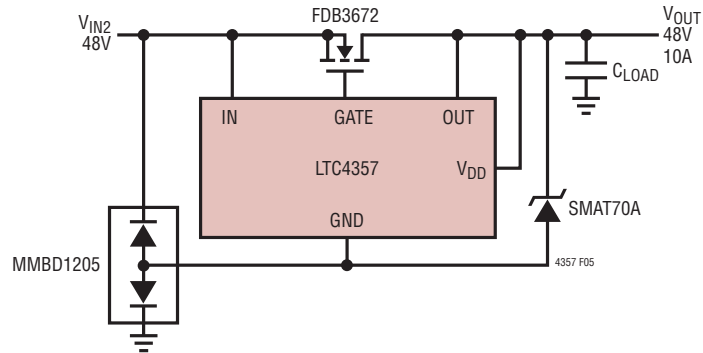

PACKAGE DESCRIPTION

DCB Package 6-Lead Plastic DFN (2mm × 3mm) (Reference LTC DWG # 05-08-1715 Rev A)

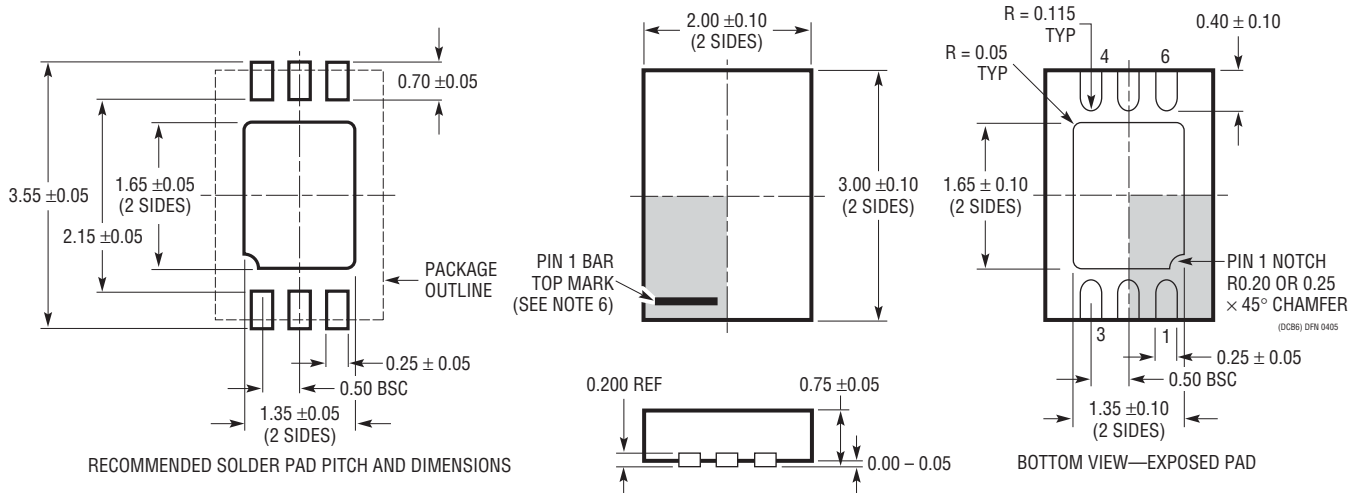

- NOTE:
1. DRAWING TO BE MADE A JEDEC PACKAGE OUTLINE M0-229 VARIATION OF (TBD)
 2. DRAWING NOT TO SCALE
 3. ALL DIMENSIONS ARE IN MILLIMETERS
 4. DIMENSIONS OF EXPOSED PAD ON BOTTOM OF PACKAGE DO NOT INCLUDE MOLD FLASH. MOLD FLASH, IF PRESENT, SHALL NOT EXCEED 0.15mm ON ANY SIDE
 5. EXPOSED PAD SHALL BE SOLDER PLATED
 6. SHADED AREA IS ONLY A REFERENCE FOR PIN 1 LOCATION ON THE TOP AND BOTTOM OF PACKAGE

MS8 Package 8-Lead Plastic MSOP (Reference LTC DWG # 05-08-1660 Rev F)

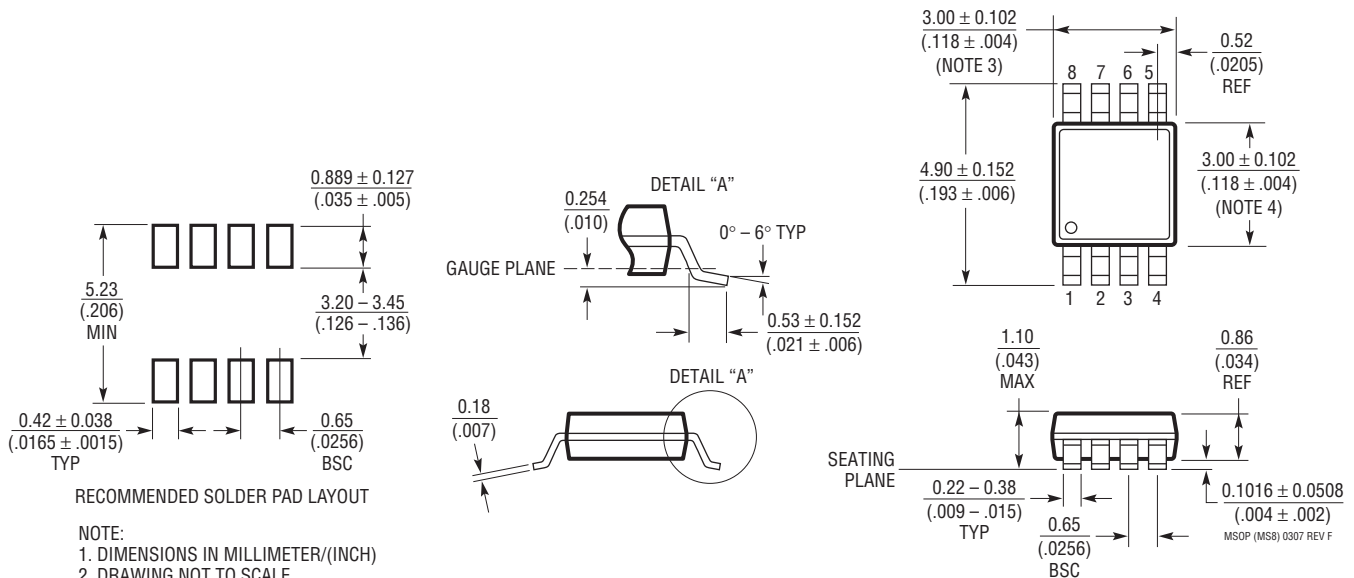

- NOTE:
1. DIMENSIONS IN MILLIMETER/(INCH)
 2. DRAWING NOT TO SCALE
 3. DIMENSION DOES NOT INCLUDE MOLD FLASH, PROTRUSIONS OR GATE BURRS. MOLD FLASH, PROTRUSIONS OR GATE BURRS SHALL NOT EXCEED 0.152mm (.006") PER SIDE
 4. DIMENSION DOES NOT INCLUDE INTERLEAD FLASH OR PROTRUSIONS. INTERLEAD FLASH OR PROTRUSIONS SHALL NOT EXCEED 0.152mm (.006") PER SIDE
 5. LEAD COPLANARITY (BOTTOM OF LEADS AFTER FORMING) SHALL BE 0.102mm (.004") MAX

TYPICAL APPLICATION

Plug-In Card Input Diode for Supply Hold-Up

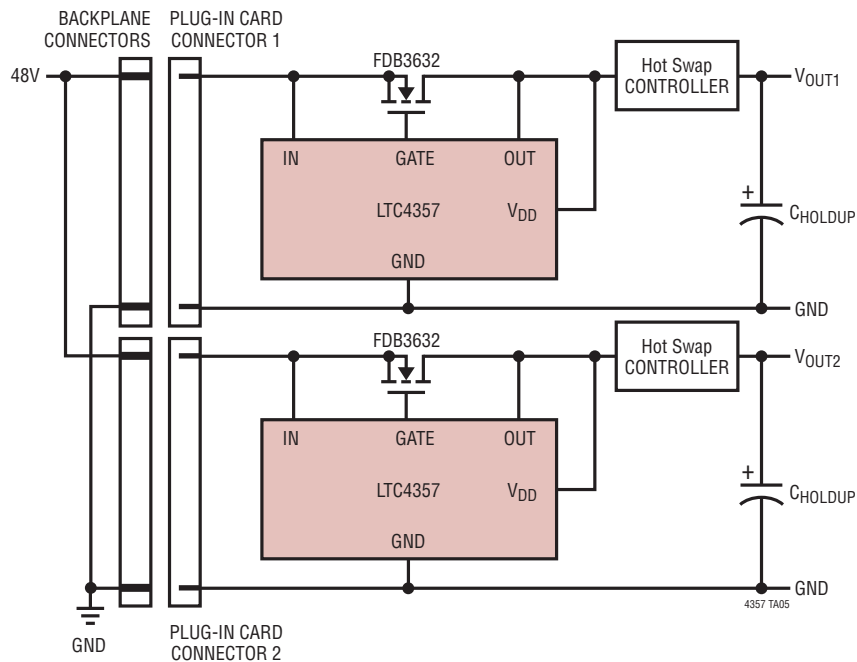

RELATED PARTS

PART NUMBER	DESCRIPTION	COMMENTS
LT1640AH/LT1640AL	Negative High Voltage Hot Swap™ Controllers in SO-8	Negative High Voltage Supplies From –10V to –80V
LT1641-1/LT1641-2	Positive High Voltage Hot Swap Controllers	Active Current Limiting, Supplies From 9V to 80V
LTC1921	Dual –48V Supply and Fuse Monitor	UV/OV Monitor, –10V to –80V Operation, MSOP Package
LT4250	–48V Hot Swap Controller	Active Current Limiting, Supplies From –20V to –80V
LTC4251/LTC4251-1/ LTC4251-2	–48V Hot Swap Controllers in SOT-23	Fast Active Current Limiting, Supplies From –15V
LTC4252-1/LTC4252-2/ LTC4252-1A/LTC4252-2A	–48V Hot Swap Controllers in MS8/MS10	Fast Active Current Limiting, Supplies From –15V, Drain Accelerated Response
LTC4253	–48V Hot Swap Controller with Sequencer	Fast Active Current Limiting, Supplies From –15V, Drain Accelerated Response, Sequenced Power Good Outputs
LT4256	Positive 48V Hot Swap Controller with Open-Circuit Detect	Foldback Current Limiting, Open-Circuit and Overcurrent Fault Output, Up to 80V Supply
LTC4260	Positive High Voltage Hot Swap Controller	With I ² C and ADC, Supplies from 8.5V to 80V
LTC4261	Negative High Voltage Hot Swap Controller	With I ² C and 10-Bit ADC, Adjustable Inrush and Overcurrent Limits
LTC4350	Hot Swappable Load Share Controller	Output Voltage: 1.2V to 20V, Equal Load Sharing
LT4351	MOSFET Diode-OR Controller	External N-Channel MOSFETs Replace ORing Diodes, 1.2V to 20V
LTC4354	Negative Voltage Diode-OR Controller and Monitor	Controls Two N-Channel MOSFETs, 1μs Turn-Off, 80V Operation
LTC4355	Positive Voltage Diode-OR Controller and Monitor	Controls Two N-Channel MOSFETs, 0.5μs Turn-Off, 80V Operation

Hot Swap is a trademark of Linear Technology Corporation.