

# LTC4020EUHF

## High Power Buck-Boost Multi-Chemistry Battery Charger

### DESCRIPTION

Demonstration circuit 2134A is a high power buck-boost multichemistry battery charger featuring the [LTC®4020](#). The board will accept an input voltage between 15V and 55V. The float voltage of the battery output (BAT) is 25.2V, with 6.3A maximum charge current. The converter output ( $V_{OUT}$ ) has a voltage range of 21V to 28V, with 8A maximum load current. The LTC4020 contains a high efficiency synchronous buck-boost DC/DC controller, and uses a proprietary average current mode architecture.

The LTC4020 battery charger can provide a constant-current/constant-voltage charge algorithm (JP1: CC/CV,

with mode pin grounded), constant-current charging (JP1: CC, with mode pin floated), or charging with an optimized 4-step, 3-stage lead-acid battery charge profile (JP1: lead-acid, with mode pin connected to INTV<sub>CC</sub>).

The LTC4020 data sheet gives a complete description of the IC operation and application information. The data sheet must be read in conjunction with this quick start guide.

**Design files for this circuit board are available at <http://www.linear.com/demo/DC2134A>**

LT, LT, LTC, LTM, Linear Technology and the Linear logo are registered trademarks of Linear Technology Corporation. All other trademarks are the property of their respective owners.

### PERFORMANCE SUMMARY Specifications are at $T_A = 25^\circ\text{C}$

PARAMETER	CONDITION	VALUE
Input Voltage Range		15V to 55V
Battery Float Voltage (BAT) (Nominal)	$I_{BAT} = 0A$	25.2V
Converter Output Voltage ( $V_{OUT}$ )	$I_{OUT} = 0A$ to 8A	21V to 28V
Maximum Battery Charge Current, $I_{BAT}$	$I_{OUT} = 0A$	6.3A
Maximum Converter Output Current, $I_{OUT}$	$I_{BAT} = 0A$	8A
Typical Efficiency	$V_{IN} = 24V, V_{OUT} = 25.2V, I_{OUT} = 8A$	98.1%
Typical Converter Output Ripple	$V_{IN} = 55V, V_{OUT} = 25.2V, I_{OUT} = 8A$ (20MHz Bandwidth)	109mV <sub>P-P</sub>

## QUICK START PROCEDURE

Demonstration circuit 2134A is easy to set up to evaluate the performance of the LTC4020. Refer to Figure 1 for the proper measurement equipment setup and follow the procedure below:

1. With power off, connect the input power supply (set for 0V) to  $V_{IN}$  and GND (input return).
2. Connect the converter output load between  $V_{out}$  and GND (Initial load: no load).
3. Connect the DVMs to the input and outputs.
4. Turn on the input power supply and slowly increase to 24V. Check for the proper output voltages,  $V_{OUT}$  of 25.2V and BAT of 25.2V.
5. Once the proper output voltages are established, adjust the converter output load within the operating range (8A maximum) and/or adjust input voltage (15V to 55V), and observe the output voltage regulation, ripple voltage, efficiency and other parameters.

Note: When measuring the output or input voltage ripple, do not use the long ground lead on the oscilloscope probe. See Figure 2 for the proper scope probe technique. Short, stiff leads need to be soldered to the (+) and (-) terminals of an output capacitor. The probe's ground ring needs to touch the (-) lead and the probe tip needs to touch the (+) lead.

### Additional Notes:

1. **CAUTION: Be careful when testing with high voltage. High voltage can result in an electric shock if care is not taken.**
2. **CAUTION: Batteries are potentially dangerous high energy sources. Improper connection, overcharge, or rapid discharge could result in explosion and/or fire. Please read the specification/manual of the battery before test.**
3. **The combined converter output load current and battery charging current should not exceed 8A.**
4. Without a proper battery, BAT output can be open or connected with other suitable loads for test purposes. It may be a good practice to add low ESR electrolytic capacitors to the BAT output ( $\geq 1000\mu\text{F}$  at  $\geq 35\text{V}$ , for 25.2V float voltage).  
  
Note: These capacitors help simulate the low impedance of a battery and maintain stability of the charge current loop. It's only needed for test purposes with electronic or resistive loads, and not needed in the actual battery application/test (where the BAT load is a battery).
5. BAT float voltage can be easily adjusted with the resistor divider R8/R10. Converter output voltage  $V_{OUT}$  can be adjusted with the resistor divider R9/R11. Adjust/optimize the loop compensations if necessary.

**QUICK START PROCEDURE**

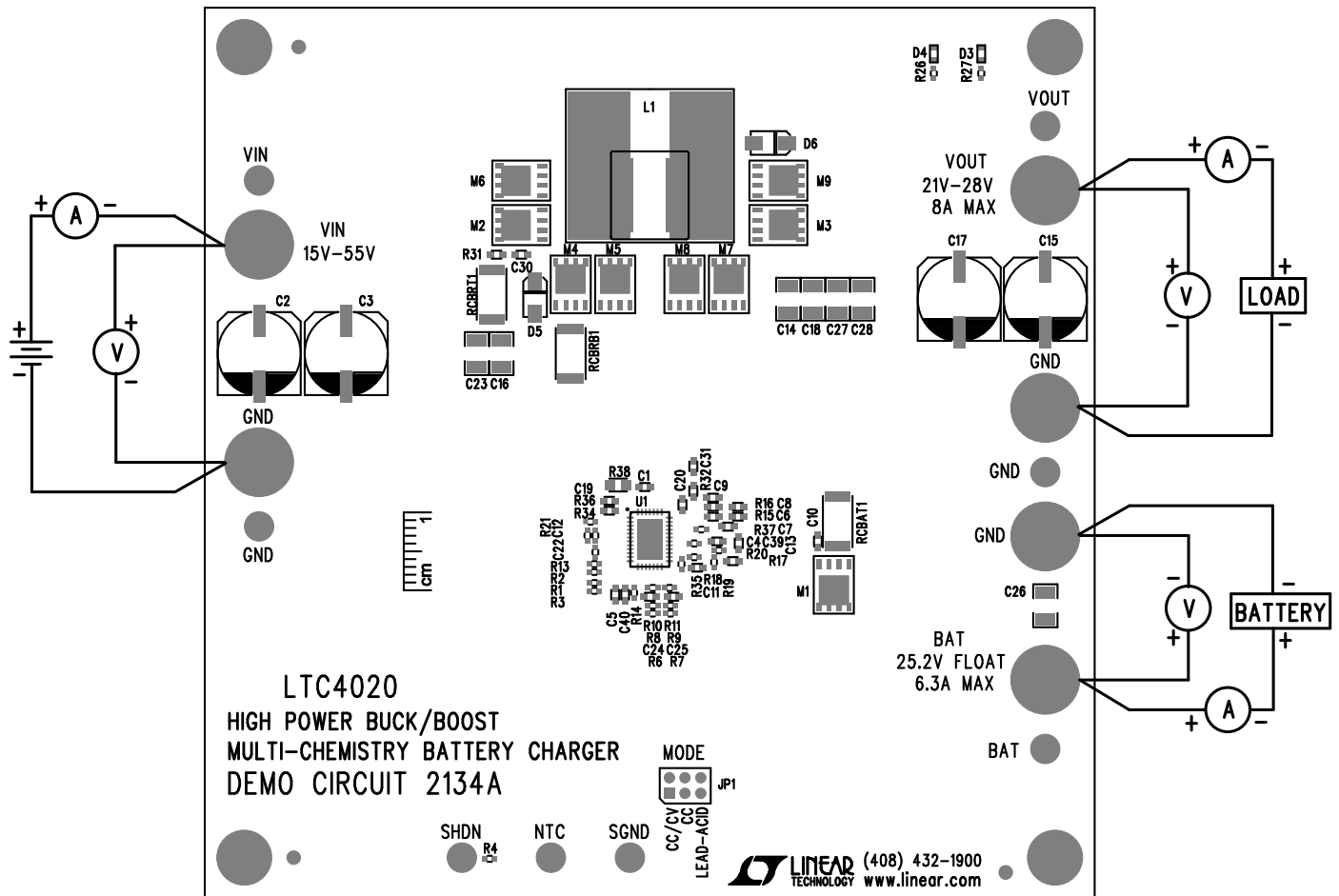

Figure 1. Proper Measurement Equipment Setup

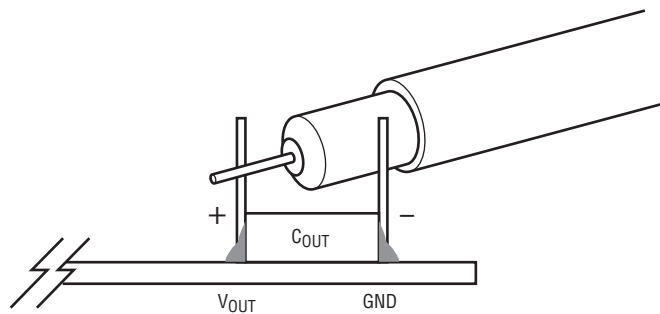

Figure 2. Measuring Output Voltage Ripple

## QUICK START PROCEDURE

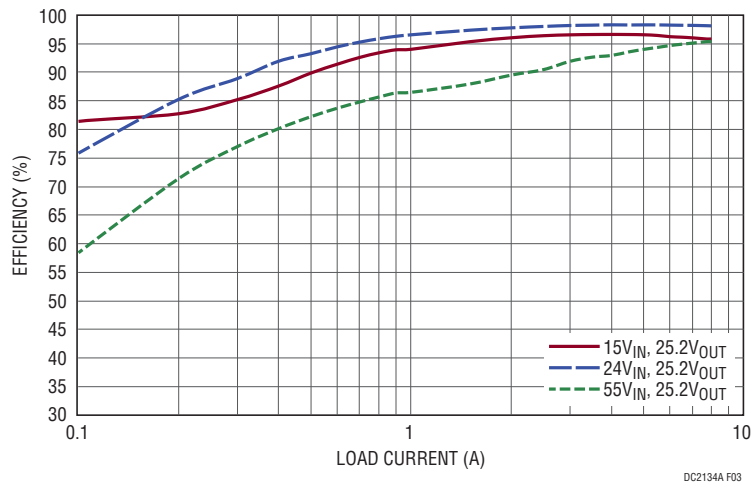

Figure 3. Efficiency vs Load Current ( $V_{OUT} = 25.2V$ )

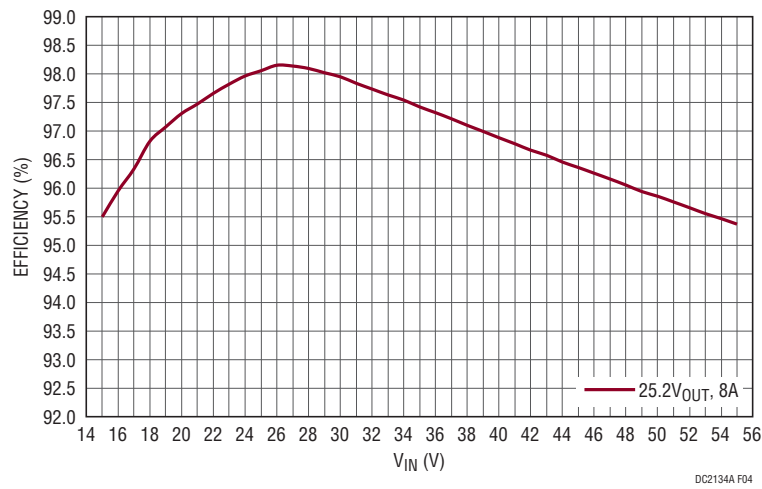

Figure 4. Efficiency vs Input Voltage ( $V_{OUT} = 25.2V$ ,  $I_{OUT} = 8A$ )

## PARTS LIST

ITEM	QTY	REFERENCE	PART DESCRIPTION	MANUFACTURER/PART NUMBER
<b>Required Circuit Components</b>				
1	1	C1	CAP, CHIP, X7S, 0.1 $\mu$ F, 10%, 100V, 0603	TDK, C1608X7S2A104K
2	2	C2,C3	CAP, ELEC., 56 $\mu$ F, 20%, 63V, 10X12.5	SUNCON, 63HVH56M
3	1	C4	CAP, CHIP, C0G, 100pF, 10%, 16V, 0402	AVX, 0402YA101KAT9A
4	1	C6	CAP., MLCC, 6800pF, 50V,10%, 0603	AVX,ESD35C682K4T2A-18
5	1	C8	CAP, CHIP, C0G, 47pF, 10%, 50V, 0603	AVX., 06035A470KAT2A
6	1	C11	CAP, CHIP, X5R, 4.7 $\mu$ F, 10%, 6.3V, 0603	AVX, 06036D475KAT2A
7	1	C12	CAP, CHIP, X7R, 0.033 $\mu$ F, 10%, 25V, 0402	TDK, C1005X7R1E333K
8	4	C14, C18, C27, C28	CAP, CHIP, X5R, 10 $\mu$ F, 20%, 35V, 1210	AVX, 1210DD106MAT2A
9	2	C15, C17	CAP, ELEC., 220 $\mu$ F, 20%, 35V 10X12.5	SUNCON, 35HVH220M
10	2	C16, C23	CAP, CHIP, X7S, 4.7 $\mu$ F, 20%, 100V, 1210	TDK,C3225X7S2A475M
11	3	C5, C19, C20	CAP, CHIP, X5R,0.22 $\mu$ F, 10%, 25V, 0603	AVX, 06033D224KAT2A
12	1	C21	CAP, CHIP, X5R, 10 $\mu$ F, 20%, 6.3V, 0805	AVX., 08056D106KAT2A
13	2	C39, C40	CAP, CHIP, X7R,0.22 $\mu$ F, 20%, 10V, 0603	AVX, 0603ZC224MAT2A
14	2	D1, D2	DIODE, SMT, SUPERBARRIER, 60V, 0.5A, SOD123	DIODES INC., SBR0560S1-7
15	1	D3	DIODE, LED, RED, SMT, 0603	WÜRTH, 150060SS75000
16	1	D4	DIODE, LED, GREEN, 0603	WÜRTH, 150060VS75000
17	1	D6	DIODE., SMT SCHOTTKY BARRIER RECTIFIER, SMA	VISHAY, B360A-E3
18	1	L1	IND, SMT, 5.6 $\mu$ H	WÜRTH, 7443556560
19	1	M1	P-CHANNEL MOSFET, -30V PowerPAKS08	VISHAY, Si7145DP-T1-GE3
20	2	M2, M4	N-CHANNEL MOSFET, 60V, PowerPAKS08	VISHAY, SiR664DP-T1-GE3
21	2	M3, M7	N-CHANNEL MOSFET, 40V, PowerPAKS08	VISHAY, SiR422DP-T1-E3
22	1	RCBAT1	RES, CHIP, 0.008 $\Omega$ , 1%, 1W, 2512	VISHAY, WSL25128L000FEA
23	2	RCBRB1, RCBRT1	RES, CHIP, 0.002 $\Omega$ , 1%, 1W, 2512	VISHAY, WSL25122L000FEA
24	2	R1, R13	RES, CHIP, 100k $\Omega$ , 5%, 0402	VISHAY, CRCW0402100KJNED
25	1	R2	RES, CHIP, 510k $\Omega$ , 5%, 0402	VISHAY, CRCW0402510KJNED
26	1	R4	RES, CHIP, 51k $\Omega$ , 1%, 0402	VISHAY, CRCW040251K0FKED
27	3	R6, R7, R19	RES, CHIP, 20 $\Omega$ , 5%, 0402	VISHAY, CRCW040220R0JNED
28	1	R8	RES, CHIP, 226k $\Omega$ , 0.1%, 0603	VISHAY, TNPW06030F226BEEA
29	1	R9	RES, CHIP, 226k $\Omega$ , 1%, 0603	VISHAY, CRCW0603226KFKEA
30	1	R10	RES, CHIP, 24.9k $\Omega$ , 0.1%, 0402	VISHAY, TNPW04020F24K9BEED
31	1	R11	RES, CHIP, 24.9k $\Omega$ , 1%, 0402	VISHAY, CRCW040224K9FKED
32	1	R14	RES, CHIP, 10k $\Omega$ , 1%, 0402	VISHAY, CRCW040210K0FKED
33	1	R15	RES, CHIP, 36k $\Omega$ , 1%, 0603	VISHAY, CRCW060336K0FKEA
34	1	R16	RES, CHIP, 47k $\Omega$ , 1%, 0603	VISHAY, CRCW060347K0FKEA
35	2	R18, R20	RES, CHIP, 100 $\Omega$ , 5%, 0402	VISHAY, CRCW0402100RJNED
36	2	R26, R27	RES, CHIP, 3k $\Omega$ , 5%, 0402	VISHAY, CRCW04023K00JNED
37	1	U1	IC, LTC4020EUHF, 5mm x 7mm QFN-38	LINEAR TECH., LTC4020EUHF

# DEMO MANUAL DC2134A

## PARTS LIST

ITEM	QTY	REFERENCE	PART DESCRIPTION	MANUFACTURER/PART NUMBER
<b>Additional Demo Board Circuit Components</b>				
1	0	C13, C7, C9, C10, C30, C31 (OPT)	CAP, CHIP, OPT 0603	OPT
2	0	C22, C24, C25 (OPT)	CAP, CHIP, OPT 0402	OPT
3	0	C26, C29, C32-C38 (OPT)	CAP, CHIP, OPT 1210	OPT
4	0	D5 (OPT)	DIODE, OPT SMA	OPT
5	0	D7 (OPT)	DIODE, OPT SOD123	OPT
6	0	M5, M6, M8, M9 (OPT)	N-CHANNEL MOSFET, OPT PowerPAKS08	OPT
7	0	R3 (OPT)	RES, OPT 0402	OPT
8	8	R21-25, R34, R35, R37	RES, CHIP, 0 $\Omega$ JUMPER, 0402	VISHAY, CRCW04020000Z0ED
9	0	R17, R31, R32 (OPT)	RES, OPT 0603	OPT
10	1	R36	RES, CHIP, 0 $\Omega$ JUMPER, 0603	VISHAY, CRCW06030000Z0EA
11	1	R38	RES, CHIP, 5.1, 5%, 0805	VISHAY, CRCW08055R10JNEA
<b>Hardware: For Demo Board Only</b>				
1	8	E1, E2, E5, E9, E10, E13, E14, E17	TURRET, 0.09" DIA	MILL-MAX, 2501-2-00-80-00-00-07-0
2	6	E3, E4, E11, E12, E15, E16	VERTICAL BANANA JACK, 575-4	KEYSTONE, 575-4
3	1	JP1	HEADER, HD2X3-079	WÜRTH, 62000311121
4	1	XJP1	SHUNT, .079" CENTER	WÜRTH, 60800213421
5	4		STAND-OFF, NYLON (SNAP ON), 0.375" TALL	KEYSTONE, 8832 (SNAP ON)

**SCHEMATIC DIAGRAM**

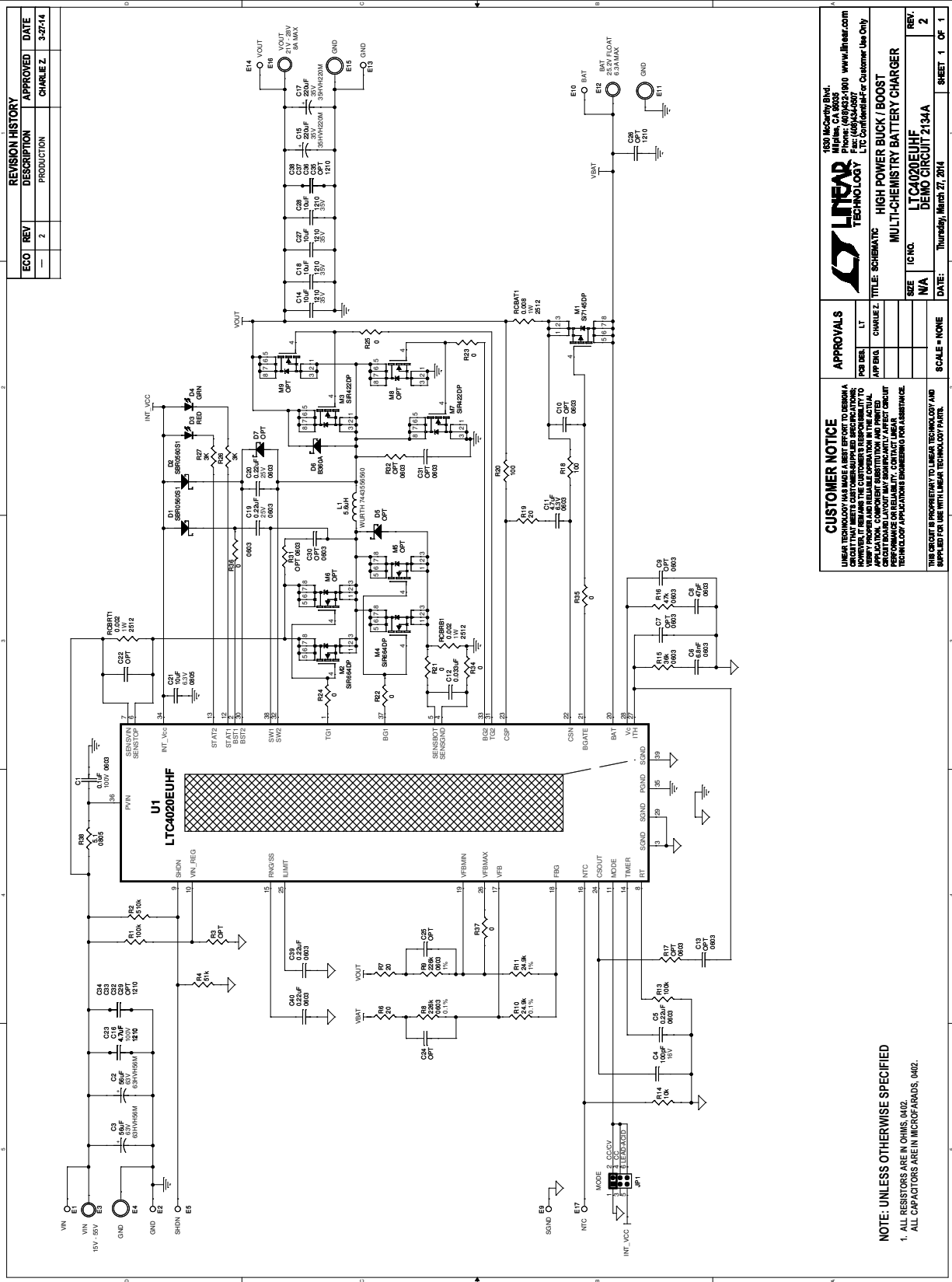

REVISION HISTORY			
ECO	REV	DESCRIPTION	DATE
—	2	PRODUCTION	3-27-14

**LINEAR TECHNOLOGY**  
 100 McCarty Blvd.  
 Phone: (913)332-1000 www.linear.com  
 Fax: (913)332-0007  
 LTC Confidential - For Customer Use Only

**CUSTOMER NOTICE**  
 LINEAR TECHNOLOGY HAS MADE A BEST EFFORT TO DESIGN A CIRCUIT THAT MEETS CUSTOMER-SPECIFIED REQUIREMENTS. HOWEVER, CUSTOMERS ARE RESPONSIBLE FOR VERIFYING THE ACTUAL APPLICATION, COMPONENT SUBSTITUTION AND PRINTED PERFORMANCE OR RELIABILITY. CONTACT LINEAR TECHNOLOGY APPLICATION ENGINEERING FOR ASSISTANCE.

**APPROVALS**  
 FOR DES: LT  
 APP ENG: CHARLEZ

**SCALE = NONE**

**IC NO.:** LTC4020EUHF  
**DEMO CIRCUIT 2134A**

**DATE:** Thursday, March 27, 2014

**SHEET 1 OF 1**

**NOTE: UNLESS OTHERWISE SPECIFIED**  
 1. ALL RESISTORS ARE IN OHMS, Ω.  
 ALL CAPACITORS ARE IN MICROFARADS, µM2.

# DEMO MANUAL DC2134A

---

## DEMONSTRATION BOARD IMPORTANT NOTICE

Linear Technology Corporation (LTC) provides the enclosed product(s) under the following **AS IS** conditions:

This demonstration board (DEMO BOARD) kit being sold or provided by Linear Technology is intended for use for **ENGINEERING DEVELOPMENT OR EVALUATION PURPOSES ONLY** and is not provided by LTC for commercial use. As such, the DEMO BOARD herein may not be complete in terms of required design-, marketing-, and/or manufacturing-related protective considerations, including but not limited to product safety measures typically found in finished commercial goods. As a prototype, this product does not fall within the scope of the European Union directive on electromagnetic compatibility and therefore may or may not meet the technical requirements of the directive, or other regulations.

If this evaluation kit does not meet the specifications recited in the DEMO BOARD manual the kit may be returned within 30 days from the date of delivery for a full refund. **THE FOREGOING WARRANTY IS THE EXCLUSIVE WARRANTY MADE BY THE SELLER TO BUYER AND IS IN LIEU OF ALL OTHER WARRANTIES, EXPRESSED, IMPLIED, OR STATUTORY, INCLUDING ANY WARRANTY OF MERCHANTABILITY OR FITNESS FOR ANY PARTICULAR PURPOSE. EXCEPT TO THE EXTENT OF THIS INDEMNITY, NEITHER PARTY SHALL BE LIABLE TO THE OTHER FOR ANY INDIRECT, SPECIAL, INCIDENTAL, OR CONSEQUENTIAL DAMAGES.**

The user assumes all responsibility and liability for proper and safe handling of the goods. Further, the user releases LTC from all claims arising from the handling or use of the goods. Due to the open construction of the product, it is the user's responsibility to take any and all appropriate precautions with regard to electrostatic discharge. Also be aware that the products herein may not be regulatory compliant or agency certified (FCC, UL, CE, etc.).

No License is granted under any patent right or other intellectual property whatsoever. **LTC assumes no liability for applications assistance, customer product design, software performance, or infringement of patents or any other intellectual property rights of any kind.**

LTC currently services a variety of customers for products around the world, and therefore this transaction **is not exclusive**.

**Please read the DEMO BOARD manual prior to handling the product.** Persons handling this product must have electronics training and observe good laboratory practice standards. **Common sense is encouraged.**

This notice contains important safety information about temperatures and voltages. For further safety concerns, please contact a LTC application engineer.

Mailing Address:

Linear Technology  
1630 McCarthy Blvd.  
Milpitas, CA 95035

Copyright © 2004, Linear Technology Corporation