

# LTC3886IUKG/LTC3870EUFD

## 60V Dual Output Step-Down DC/DC Controller with Digital Power System Management

### DESCRIPTION

Demonstration circuit 2155A is available in two configurations. The DC2155A-A is a dual output synchronous step-down converter featuring the [LTC®3886IUKG](#), a dual-phase current mode controller. The DC2155A-B is a single output synchronous step-down converter that operates with four phases: two from the LTC3886IUKG and two from LTC3870EUFD, a phase extender. Both versions have a PMBus interface and digital power system management functions.

The DC2155A uses discrete MOSFETs in the power stage. The input range of this board is from 18V to 54V. The output voltage can be programmed from 5V to 12V with an output current of up to 12A per phase. For the DC2155A-A version, the factory default setting for the CH0 output is 12V and CH1 output is 5V. In addition, this demo board has an on-board dynamic load circuit, which makes it easy to evaluate the transient performances.

The DC2155A powers up to default settings and produces power based on configuration resistors or its program file loaded within its onboard EEPROM without the need for

any serial bus communication. This allows easy evaluation of the DC/DC converter aspects of the LTC3886. To fully explore the extensive power system management features of the parts, download the GUI software LTpowerPlay® onto your PC and use LTC's I<sup>2</sup>C/SMBus/PMBus Dongle DC1613A to connect to the board. LTpowerPlay allows the user to reconfigure the part on the fly and store the configuration in EEPROM, view telemetry of voltage, current, temperature and fault status.

### GUI Software Download

The software can be downloaded from:

<http://www.linear.com/ltpowerplay>

For more details and instructions of LTpowerPlay, please refer to "LTpowerPlay for LTC3880 Quick Start Guide".

**Design files for this circuit board are available at**  
<http://www.linear.com/demo/DC2155A>

LT, LT, LTC, LTM, Linear Technology, the Linear logo and LTpowerPlay are registered trademarks of Linear Technology Corporation. All other trademarks are the property of their respective owners.

### PERFORMANCE SUMMARY Specifications are at T<sub>A</sub> = 25°C

#### DC2155A-A Assembly (Dual Output, LTC3886 Only)

SYMBOL	PARAMETER	CONDITIONS	MIN	TYP	MAX	UNITS
V <sub>IN</sub>	Input Supply Range		18	32	54	V
FSW	Factory Default Switching Frequency			150		kHz
V <sub>OUT0</sub>	CH0 Factory Default Output Voltage	I <sub>OUT0</sub> = 0A to 12A, V <sub>IN</sub> = 18V to 54V		12		V
I <sub>OUT0</sub>	CH0 Output Current Range		0		12	A
EFF	CH0 Efficiency	V <sub>OUT0</sub> = 12V, V <sub>IN</sub> = 32V, I <sub>OUT</sub> = 12A, See Figure 6a		96.3		%
V <sub>OUT1</sub>	CH1 Factory Default Output Voltage	I <sub>OUT1</sub> = 0A to 12A, V <sub>IN</sub> = 18V to 54V		5		V
I <sub>OUT1</sub>	CH1 Output Current Range		0		12	A
EFF	CH1 Efficiency	V <sub>OUT1</sub> = 5V, V <sub>IN</sub> = 32V, I <sub>OUT</sub> = 12A, See Figure 6b		93.6		%

# DEMO MANUAL

## DC2155A-A/DC2155A-B

### PERFORMANCE SUMMARY Specifications are at $T_A = 25^\circ\text{C}$

#### DC2155A-B Assembly (Four-Phase Single Output, LTC3886 and LTC3870)

SYMBOL	PARAMETER	CONDITIONS	MIN	TYP	MAX	UNITS
$V_{IN}$	Input Supply Range		18	32	54	V
$V_{OUT0}$	Factory Default Output Voltage	$I_{OUT} = 0\text{A TO } 48\text{A}$ , $V_{IN} = 18\text{V to } 54\text{V}$		12		V
$I_{OUT0}$	Output Current Range		0		48	A
FSW	Factory Default Switching Frequency			150		kHz
EFF	Efficiency	$V_{IN} = 32\text{V}$ , $V_{OUT} = 12\text{V}$ , $I_{OUT} = 48\text{A}$ , See Figure 7		96.6		%

### QUICK START PROCEDURE

Demonstration circuit 2155A makes it easy to set up to evaluate the performances of the LTC3886. Refer to Figures 1 and 2 for proper measurement equipment setup and follow the procedure below:

NOTE. When measuring the input or output voltage ripple, care must be taken to avoid a long ground lead on the oscilloscope probe. Measure the output voltage ripple by touching the probe tip directly across the C10 for CH0 and C26 for CH1. See Figure 5 for proper scope probe technique.

1. Make sure jumpers are in the following positions:

JUMPER	POSITION	FUNCTION
JP1	ON	EXT 5V (on-board bias supply) for $EXTV_{CC}$ and dynamic load circuit
JP2	NC for DC2155A-A; C for DC2155A-B	$\overline{\text{FAULT}}_0$ to $\overline{\text{FAULT}}_1$
JP3	NC for DC2155A-A; C for DC2155A-B	RUN0 to RUN1
JP5	INT	External or on-board pulse generator for transient circuit
JP6	OFF	On-board pulse generator ON/OFF

2. With power off, connect the input power supply to  $V_{IN}$  and GND. Connect active load to output.

3. Make sure both RUN switches (SW1, SW2) are OFF.
4. Turn on the power at the input.  
NOTE. Make sure that the input voltage does not exceed 54V.
5. Turn on both SW1 (for RUN0), and SW2 (for RUN1) switches, as desired.
6. Check for the correct output voltage from E5 to E6 for CH0, E7 to E8 for CH1. For DC2155A-A version,  $V_{OUT0} = 12.0\text{V} \pm 0.5\%$  (11.94V ~ 12.06V),  $V_{OUT1} = 5\text{V} \pm 0.5\%$  (4.975V ~ 5.025V). For DC2155A-B version,  $V_{OUT0} = 12.0\text{V} \pm 0.5\%$  (11.94V ~ 12.06V).

NOTE. If there is no output, temporarily disconnect the load to make sure that the load is not set too high.

7. Once the proper output voltage is established, adjust the loads within the operating range and observe the output voltage regulation, ripple voltage, efficiency and other parameters.
8. Connect the dongle and control the output voltage from the GUI. See "LTpowerPlay QUICK START" session for details.

## QUICK START PROCEDURE

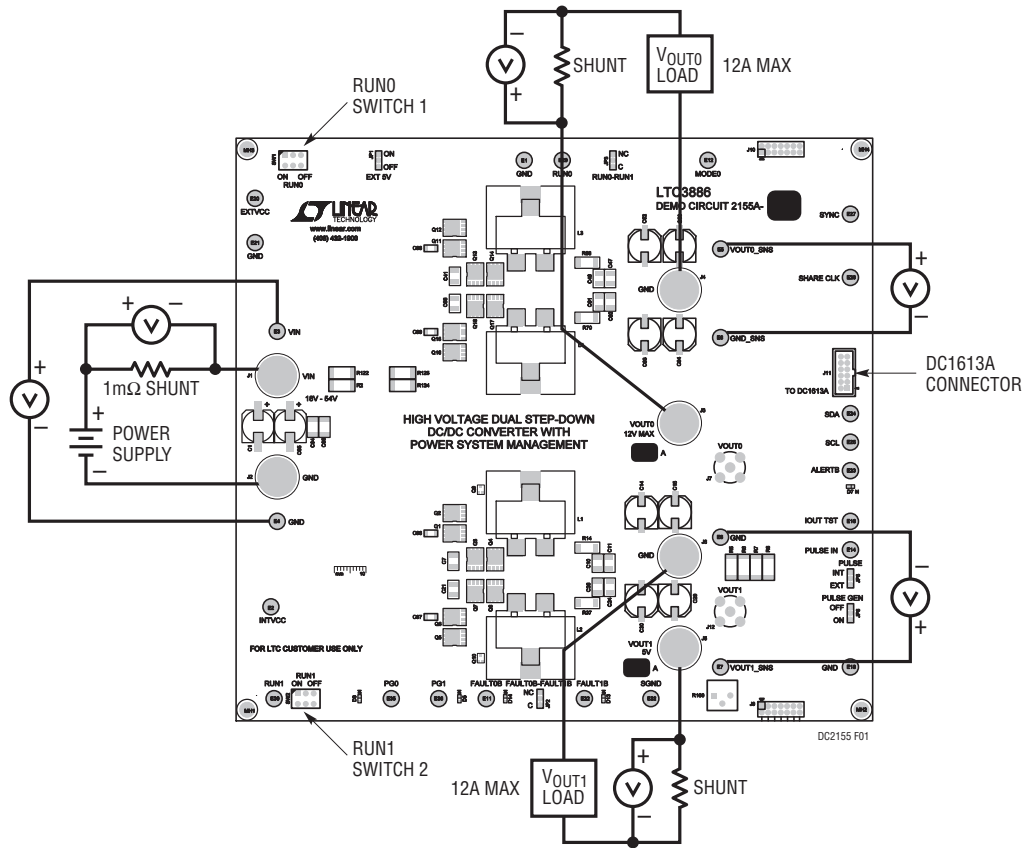

Figure 1. Test Setup for DC2155A-A

# DEMO MANUAL

## DC2155A-A/DC2155A-B

### QUICK START PROCEDURE

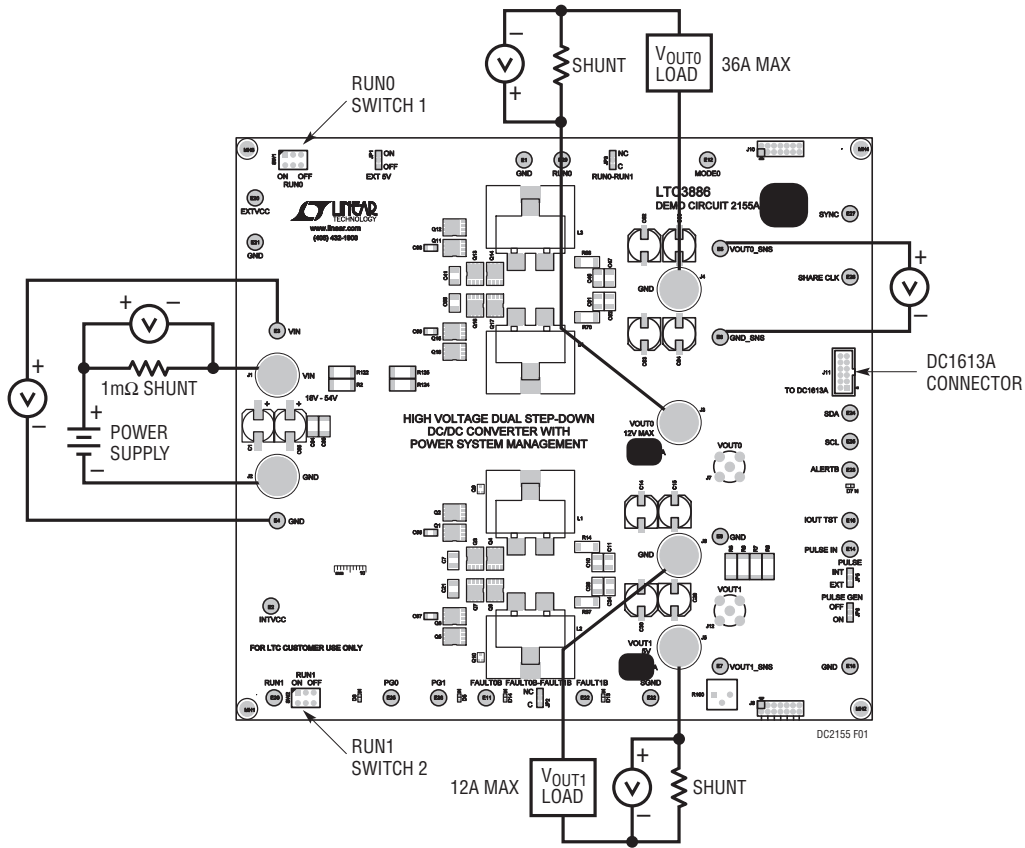

Figure 2. Test Setup for DC2155A-B

### QUICK START PROCEDURE

#### Connecting a PC to DC2155A

You can use a PC to reconfigure the power management features of the LTC3886 such as: nominal  $V_{OUT}$ , margin set points, OV/UV limits, temperature fault limits, sequenc-

ing parameters, the fault log, fault responses, GPIO and other functionality. The DC1613A dongle may be plugged in regardless of whether or not  $V_{IN}$  is present. Dongle can be hot plugged.

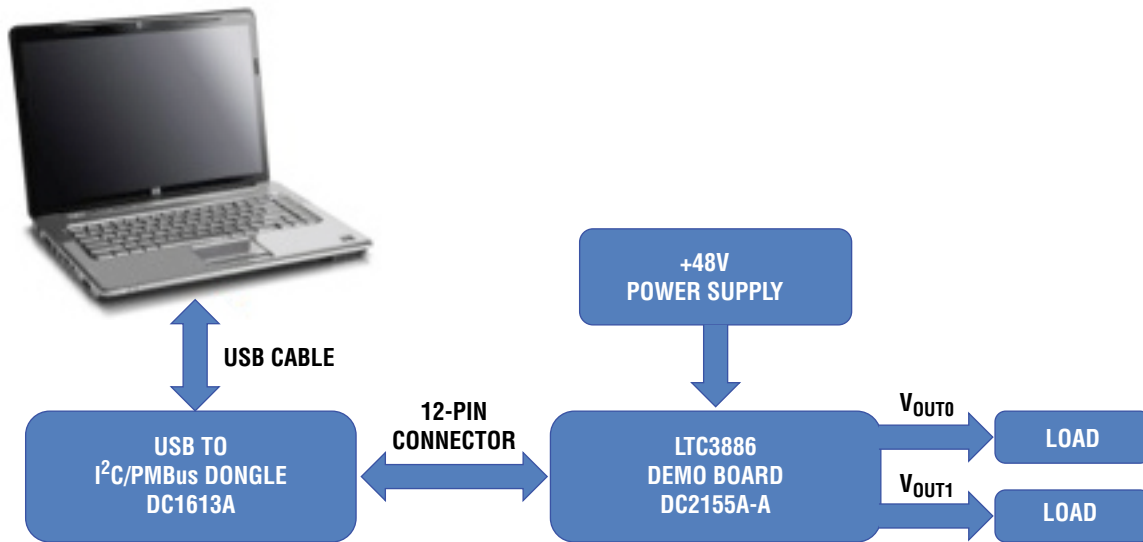

Figure 3. Demo Setup with PC for DC2155A-A

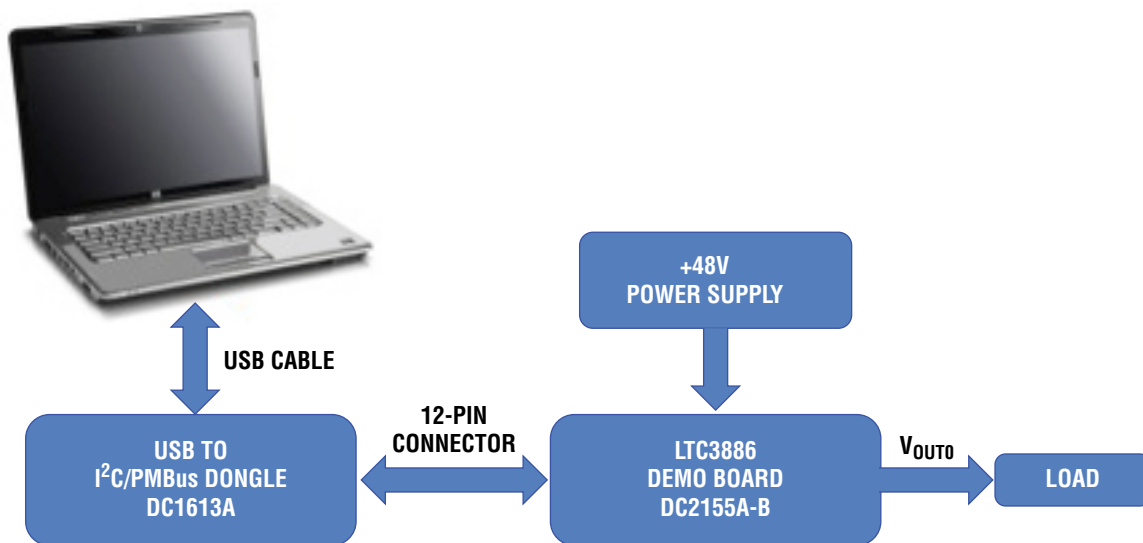

Figure 4. Demo Setup with PC for DC2155A-B

### QUICK START PROCEDURE

#### Measuring Efficiency

To accurately measure efficiency of any configuration, do the following:

- Set JP6 to OFF position to disable the pulse generator circuits.
- DC2155A-A version. Measure  $V_{IN}$  across the input ceramic capacitor (C7 for CH0, C21 for CH1). Measure  $V_{OUT}$  across the output ceramic capacitor (C10 for CH0, C26 for CH1).

- DC2155A-B version. Measure  $V_{IN}$  across the input ceramic capacitor C7. Measure  $V_{OUT}$  across the output ceramic capacitor C10.

#### Measuring Output Ripple Voltage

An accurate ripple measurement may be performed by using the below configuration across C10/C26.

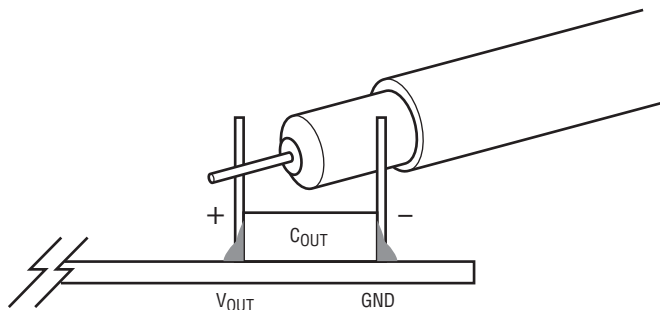
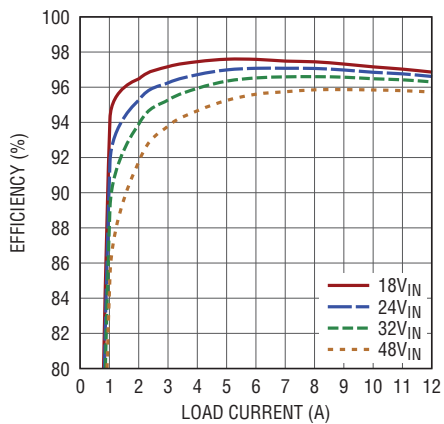

Figure 5. Measuring Output Voltage Ripple



$I_{LOAD} = 0A$  to  $12A$   
 $f_{SW} = 150kHz$   
 $EXTV_{CC} = 12V$  (TIED TO  $V_{OUT}$ )  
 ONE OUTPUT RAIL IS  
 ENABLED AT A TIME.

DC2155 F06a

Figure 6a. DC2155A-A: Efficiency at  $12V_{OUT}$

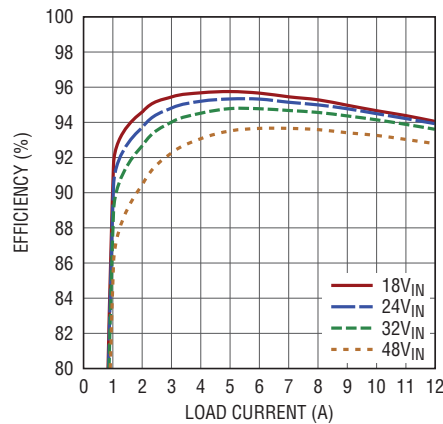

$I_{LOAD} = 0A$  to  $12A$   
 $f_{SW} = 150kHz$   
 $EXTV_{CC} = 5V$  (TIED TO  $V_{OUT}$ )  
 ONE OUTPUT RAIL IS  
 ENABLED AT A TIME.

DC2155 F06b

Figure 6b. DC2155A-A: Efficiency at  $5V_{OUT}$

### QUICK START PROCEDURE

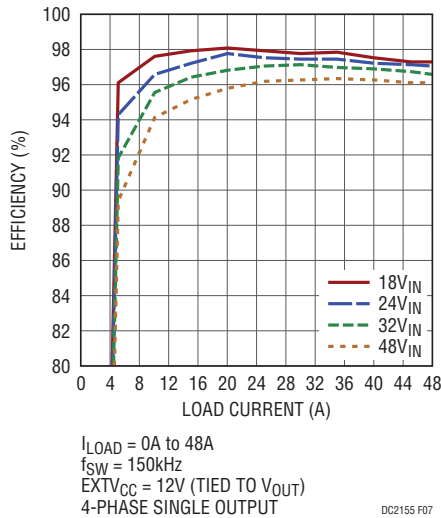
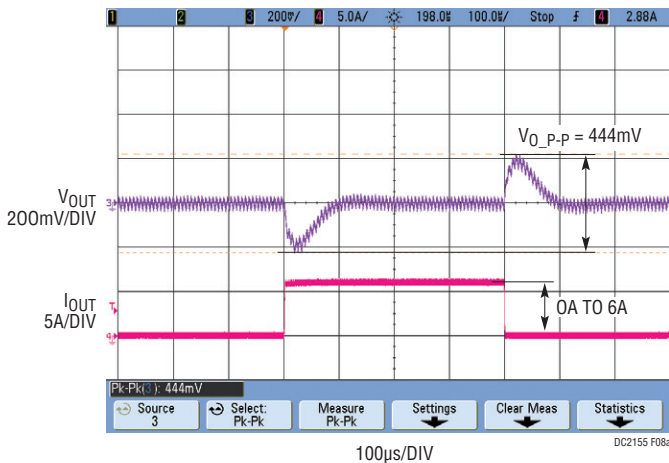
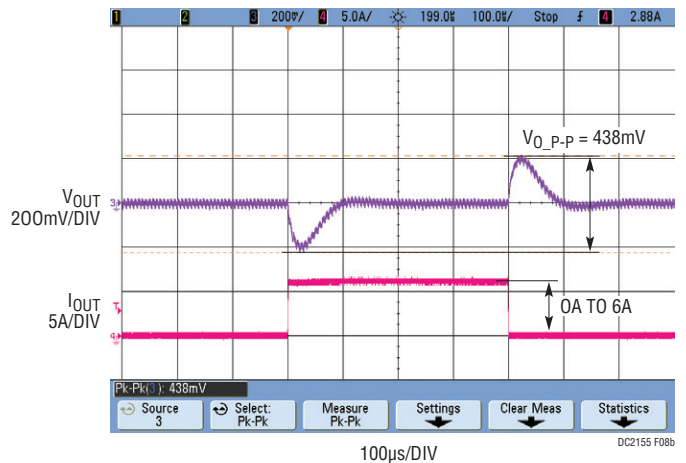

Figure 7. DC2155A-B: Efficiency at 12V<sub>OUT</sub>



$V_{IN} = 32V$   
 $V_{OUT0} = 12V$   
 $f_{SW} = 150kHz$   
 $I_{LOAD \text{ STEP}} = 0A \text{ TO } 6A \text{ AT } 6A/\mu s$   
 (DEFAULT SET-UP)

Figure 8a. DC2155A-A Load Step Response



$V_{IN} = 32V$   
 $V_{OUT1} = 5V$   
 $f_{SW} = 150kHz$   
 $I_{LOAD \text{ STEP}} = 0A \text{ TO } 6A \text{ AT } 6A/\mu s$   
 (DEFAULT SET-UP)

Figure 8b. DC2155A-A Load Step Response

# DEMO MANUAL

## DC2155A-A/DC2155A-B

### QUICK START PROCEDURE

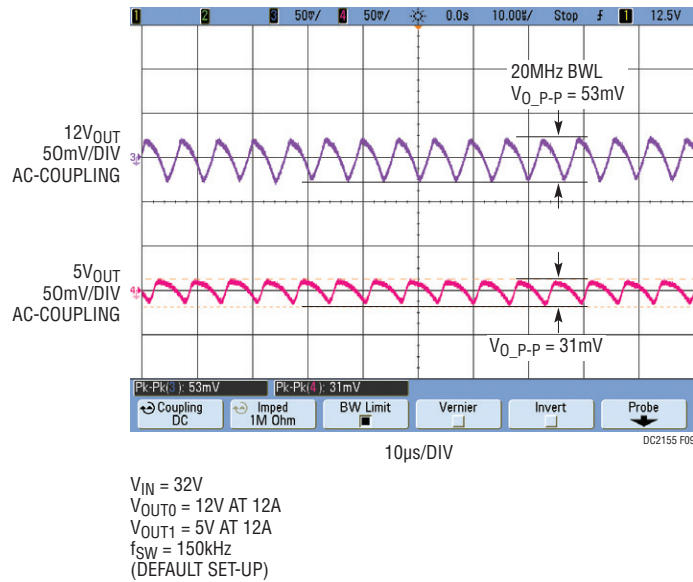
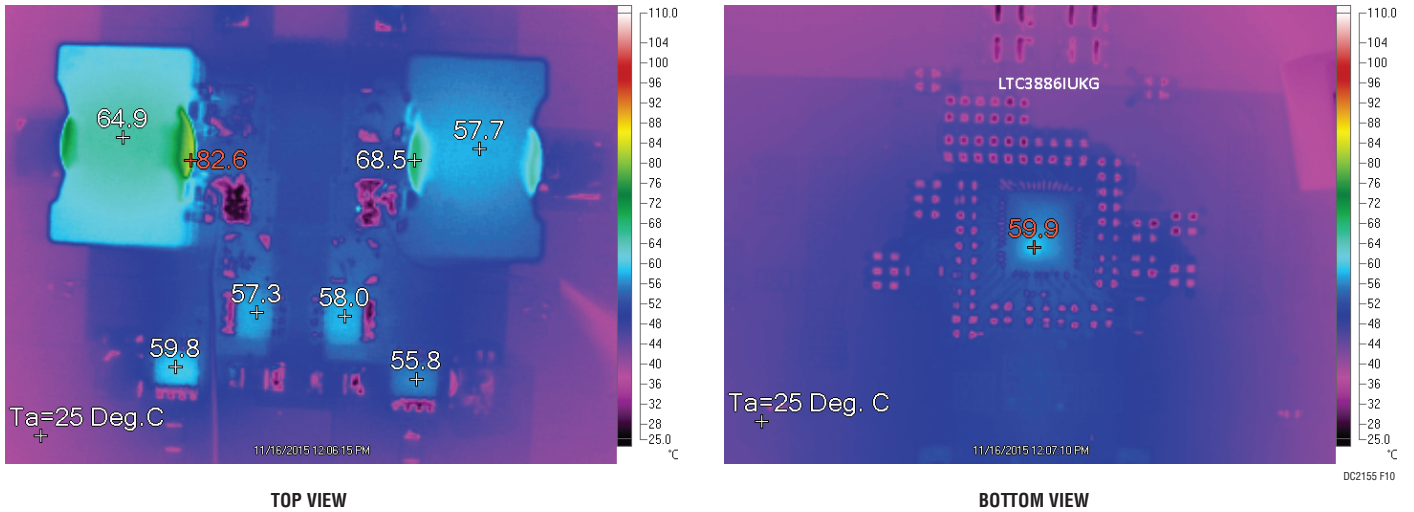

Figure 9. DC2155A-A Output Ripple Voltages



$V_{IN} = 32V$   
 $V_{OUT0} = 12V \text{ AT } 12A$   
 $V_{OUT1} = 5V \text{ AT } 12A$   
 $f_{SW} = 150kHz$   
 $EXTV_{CC} = 12V \text{ (TIED TO } V_{OUT})$   
 $T_A = 25^\circ C$   
 NO FORCED AIRFLOW  
 (DEFAULT SET-UP)

Figure 10. DC2155A-A Thermal Performance



### QUICK START PROCEDURE

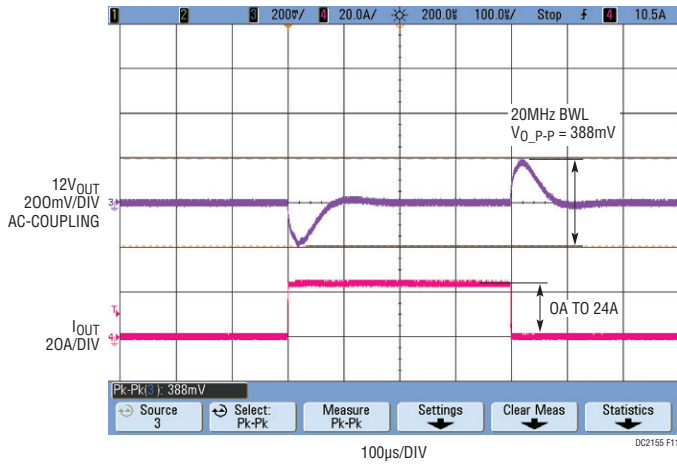

$V_{IN} = 32V$   
 $V_{OUT0} = V_{OUT1} = 12V$   
 $f_{sw} = 150kHz$   
 $I_{LOAD STEP} = 0A TO 24A AT 24\mu s$  (DEFAULT SET-UP)

Figure 11. DC2155A-B Load Step Response  $V_{IN} = 32V$

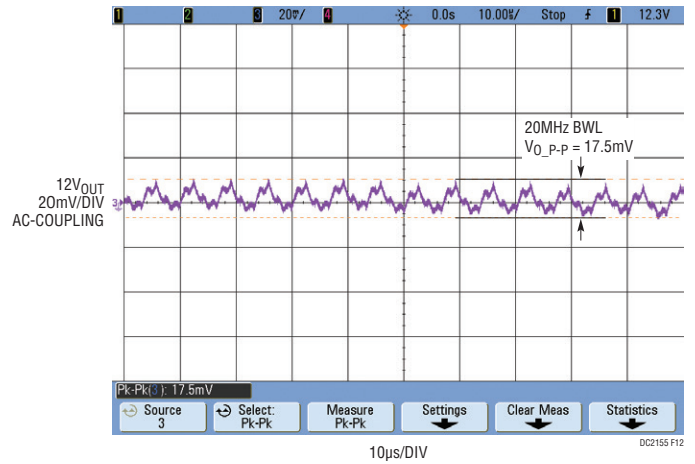

$V_{IN} = 32V$   
 $V_{OUT0} = V_{OUT1} = 12V AT 48A$   
 $f_{sw} = 150kHz$   
 (DEFAULT SET-UP)

Figure 12. DC2155A-B Output Ripple Voltages

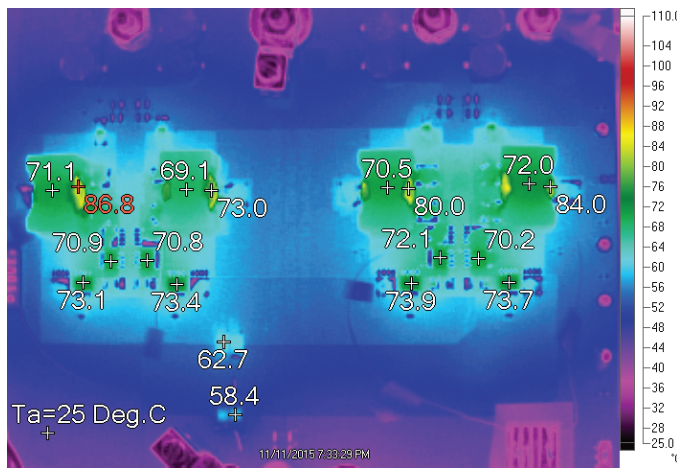

TOP VIEW

$V_{IN} = 32V$   
 $V_{OUT0} = V_{OUT1} = 12V AT 48A$   
 $f_{sw} = 150kHz$   
 $LTC3886 EXT_{V_{CC}} = 12V$  (TIED TO  $V_{OUT0}$ )

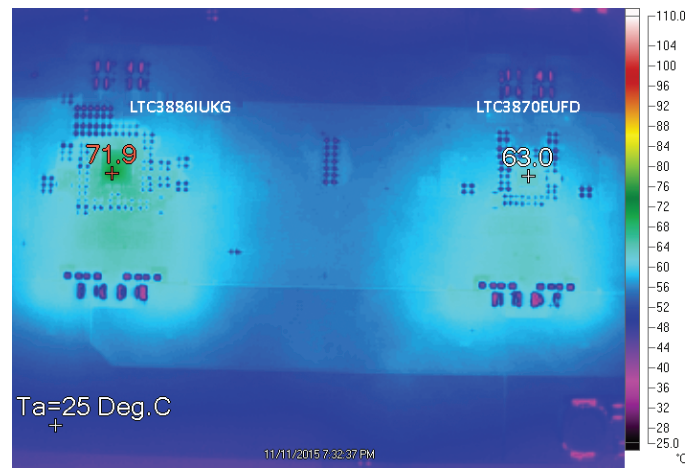

BOTTOM VIEW

$LTC3870 EXT_{V_{CC}} = 5V$  (TIED TO 5V ON-BOARD  
 EXTERNAL BIAS SUPPLY VOLTAGE FROM U3)  
 $T_A = 25^{\circ}C$   
 NO FORCED AIRFLOW  
 (DEFAULT SET-UP)

Figure 13. DC2155A-B Thermal Performance

# DEMO MANUAL

## DC2155A-A/DC2155A-B

### LTpowerPlay SOFTWARE GUI

LTpowerPlay is a powerful Windows based development environment that supports Linear Technology power system management ICs, including the LTC3880, LTC3883, LTC3882, LTC3887 and LTC3886. The software supports a variety of different tasks. You can use LTpowerPlay to evaluate Linear Technology ICs by connecting to a demo board system. LTpowerPlay can also be used in an offline mode (with no hardware present) in order to build a multichip configuration file that can be saved and reloaded at a later time. LTpowerPlay provides unprecedented diagnostic and debug features. It becomes a valuable diagnostic tool during board bring-up to program or tweak the power management scheme in a system, or to diagnose power

issues when bringing up rails. LTpowerPlay utilizes the DC1613A USB-to-SMBus controller to communicate with one of many potential targets, including the LTC3886's DC2155A demo system, or a customer board. The software also provides an automatic update feature to keep the software current with the latest set of device drivers and documentation. The LTpowerPlay software can be downloaded from:

<http://www.linear.com/ltpowerplay>

To access technical support documents for LTC Digital Power Products visit Help. View online help on the LTpowerPlay menu.

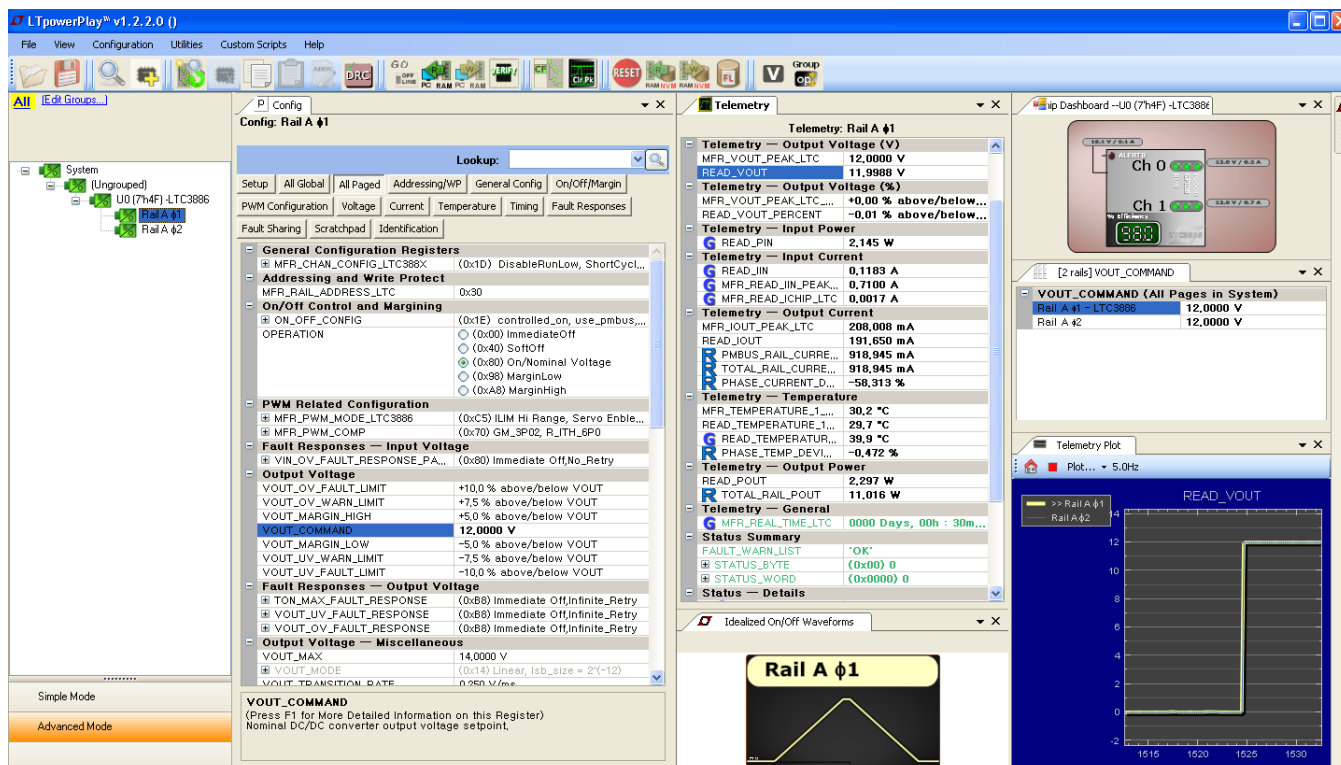

Figure 14. LTpowerPlay Main Interface

## LTpowerPlay QUICK START PROCEDURE

The following procedure describes how to use LTpowerPlay to monitor and change the settings of LTC3886.

1. Download and install the LTpowerPlay GUI:

<http://www.linear.com/ltpowerplay>

2. Launch the LTpowerPlay GUI.

- a. The GUI should automatically identify the DC2155A. The system tree on the left hand side should look like this:

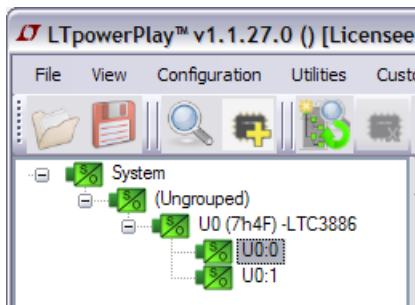

- b. A blue message box shows for a few seconds in the lower left hand corner, confirming that the LTC3886 is communicating:

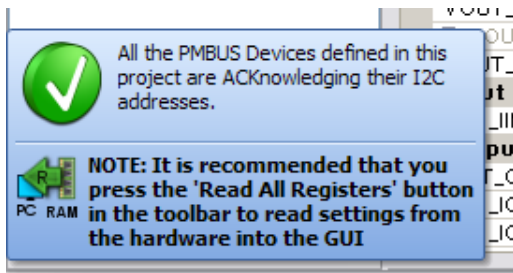

- c. In the Toolbar, click the “R” (RAM to PC) icon to read the RAM from the LTC3886. This reads the configuration from the RAM of LTC3886 and loads it into the GUI.



- d. If you want to change the output voltage to a different value, like 10V: in the Config tab, type in 10 in the VOUT\_COMMAND box, like this:

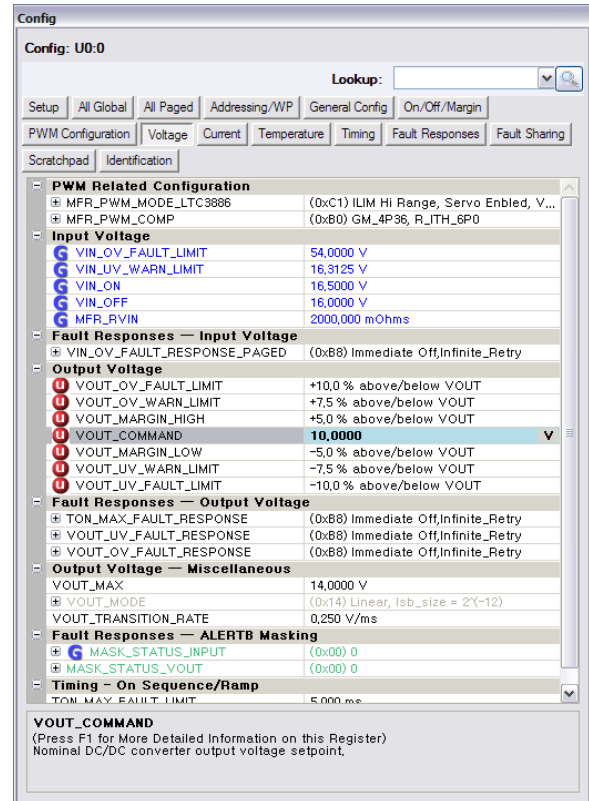

Then, click the “W” (PC to RAM) icon to write these register values to the LTC3886. After finishing this step, you will see the output voltage will change to 10V.



If the write is successful, you will see the following message:



# DEMO MANUAL

## DC2155A-A/DC2155A-B

### LTpowerPlay QUICK START PROCEDURE

- e. You can save the changes into the NVM. In the tool bar, click “RAM to NVM” button, as following:
- f. Save the demo board configuration to a (\*.proj) file. Click the Save icon and save the file with a new file name.



### PARTS LIST DC2155A-A

ITEM	QTY	REFERENCE	PART DESCRIPTION	MANUFACTURER/PART NUMBER
<b>DC2155A-A Required Circuit Components</b>				
1	2	C1, C85	CAP, 56µF 20% 63V ELEC	SUNCON 63HVP56M
2	3	C3, C9, C23	CAP, 0603 0.1µF 10% 100V X7R	MURATA GRM188R72A104KA35D
3	4	C4, C5, C27, C33	CAP, 0603 10nF 10% 100V X7R	MURATA GRM188R72A103KA01D
4	1	C6	CAP, 0603 1nF 10% 100V X7R	AVX 06031C102KAT2A
5	5	C7, C8, C21, C22, C74	CAP, 1210 2.2µF 10% 100V X7R	MURATA GRM32ER72A225KA35L
6	8	C10, C11, C12, C24, C25, C26, C88, C93	CAP, 1210 22µF 20% 16V X7R	AVX 1210YC226MAT2A
7	2	C13, C28	CAP, 0603 1nF 10% 16V X7R	AVX 0603YC102KAT2A
8	4	C14, C15, C29, C30	CAP, 150µF 16V ELEC. OS-CON	PANASONIC 16SVP150M
9	2	C18, C34	CAP, 0603 4.7nF 10% 50V X7R	AVX 06035C472KAT2A
10	2	C20, C36	CAP, 0603 100pF 5% 50V C0G	AVX 06035A101JAT2A
11	2	C37, C38	CAP, 0603 2.2µF 10% 16V X5R	AVX 0603YD225KAT2A
12	1	C39	CAP, 0603 4.7µF 10% 10V X5R	AVX 0603ZD475KAT2A
13	1	C40	CAP, 0603 4.7µF 10% 16V X5R	MURATA GRM188R61C475KAAJD
14	2	C70, C103	CAP, 0805 2.2µF 10% 16V X7R	AVX 0805YC225KAT2A
15	1	C72	CAP, 0603 47nF 10% 25V X7R	AVX 06033C473KAT2A
16	1	C76	CAP, 0603 0.1µF 10% 25V X7R	AVX 06033C104KAT2A
17	1	C78	CAP, 0805 220nF 10% 100V X7R	MURATA GRM21AR72A224KAC5L
18	2	C79, C80	CAP, 1210 100µF 20% 10V X5R	MURATA GRM32ER61A107ME20L
19	1	C81	CAP, 0603 220pF 10% 50V X7R	AVX 06035C221KAT2A
20	2	C82, C83	CAP, 0603 10nF 10% 25V X7R	AVX 06033C103KAT2A
21	2	C84, C101	CAP, 0603 100nF 20% 16V X7R	AVX 0603YC104MAT2A
22	2	C94, C95	CAP, 1812 10µF 20% 100V X7S	TDK CKG45NX7S2A106M500JH
23	2	C96, C97	CAP, 1206 2.2µF 10% 100V X7R	MURATA GRM31CR72A225KA73L
24	1	C100	CAP, 0603 150pF 5% 50V NPO	AVX 06035A151JAT2A
25	1	C102	CAP, 0603 1µF 20% 25V X5R	AVX 06033D105MAT2A
26	2	D1, D2	DIODE, SCHOTTKY 100V, 1A	DIODES/ZETEX, DFSL1100-7
27	4	D5, D6, D13, D14	LED, 0603 GREEN	OSRAM LG L29K-G2J1-24-Z
28	1	D7	LED, 0603 RED	OSRAM LS L29K-H1J2-1-Z
29	2	L1, L2	IND, 8.6µH	WURTH ELEKTRONIK 7443630860
30	1	L5	IND, 68µH	SUMIDA CDRH105RNP-680NC

# DEMO MANUAL

## DC2155A-A/DC2155A-B

### PARTS LIST DC2155A-A

ITEM	QTY	REFERENCE	PART DESCRIPTION	MANUFACTURER/PART NUMBER
31	2	Q1, Q6	XSTR, MOSFET N-CH 60V 25A 5 PIN LPAK	RENESAS RJK0651DPB
32	2	Q3, Q7	XSTR, MOSFET N-CH 60V 45A 5 PIN LPAK	RENESAS RJK0653DPB
33	2	Q9, Q10	XSTR, PNP GENERAL PURPOSE SOT-323	DIODES INC. MMST3906-7-F
34	1	Q19	XSTR, MOSFET N-CH 30V 30A 5 PIN LPAK	RENESAS RJK0305DPB-00#J0
35	1	Q20	XSTR, MOSFET P-CH 20V 5.2A SOT-23	VISHAY SI2365EDS-T1-GE3
36	4	Q22, Q23, Q28, Q29	XSTR, MOSFET N-CH 60V 115mA SOT-23	FAIRCHILD 2N7002A
37	2	R2, R122	RES, 2512 0.006Ω 1% 1W	PANASONIC ERJ-M1WSF6MU
38	2	R3, R4	RES, 0603 1k 5% 1/10W	VISHAY CRCW06031K00JNEA
39	4	R9, R12, R30, R38	RES, 0603 2Ω 5% 1/10W	VISHAY CRCW06032R00JNEA
40	12	R10, R11, R13, R15, R16, R18, R23, R25, R28, R89, R112, R113	RES, 0603 10k 5% 1/10W	VISHAY CRCW060310K0JNEA
41	2	R14, R37	RES, 2010 3mΩ 1% 1/2W	VISHAY WSL20103L000FEA
42	3	R17, R21, R22, R27, R43, R44, R45, R96, R98, R106, R109, R128, R129, R132, R168, R174	RES, 0603 0Ω JUMPER	VISHAY CRCW06030000Z0EA
43	5	R24, R26, R50, R51, R155	RES, 0603 100Ω 5% 1/10W	VISHAY CRCW0603100RJNEA
44	4	R87, R88, R171, R172	RES, 0603 200Ω 5% 1/10W	VISHAY CRCW0603200RJNEA
45	1	R91	RES, 2010 0.01Ω 1% 1/2W	VISHAY WSL2010R0100FEA
46	1	R93	RES, 0603 127Ω 1% 1/10W	VISHAY CRCW0603127RFKEA
47	1	R99	RES, 0603 220k 5% 1/10W	VISHAY CRCW0603220KJNEA
48	2	R114, R115	RES, 0603 10Ω 5% 1/10W	VISHAY CRCW060310RJNEA
49	2	R119, R120	RES, 0603 4.99k 1% 1/10W	VISHAY CRCW06034K99FKEA
50	2	R124, R125	RES, 2512 0Ω JUMPER	VISHAY CRCW25120000Z0EG
51	1	R146	RES, 0805 4.7Ω 1% 0.125W	VISHAY CRCW08054R70FKEA
52	1	R151	RES, 0603 1M 5% 1/10W	VISHAY CRCW06031M00JNEA
53	1	R152	RES, 0603 681k 1% 1/10W	VISHAY CRCW0603681KFKEA
54	1	R153	RES, 0603 3.3Ω 1% 1/10W	VISHAY CRCW06033R30FKEA
55	1	R154	RES, 0603 82.5Ω 1% 1/10W	VISHAY CRCW060382R5FKEA
56	1	R157	RES, 0603 2Ω 5% 1/10W	VISHAY CRCW06032R00JNEA
57	1	R158	RES, 0603 27.4k 1% 1/10W	VISHAY CRCW060327K4FKEA
58	1	R159	RES, 0603 226k 1% 1/10W	VISHAY CRCW0603226KFKEA
59	1	R160	RES, VARIABLE 5k	BOURNS 3386P-1-502-LF
60	1	R161	RES, 0603 20k 5% 1/10W	VISHAY CRCW060320K0JNEA
61	1	R162	RES, 1206 0Ω JUMPER	VISHAY CRCW12060000Z0EA
62	1	R170	RES, 0603 340Ω 1% 1/10W	VISHAY CRCW0603340KFKEA
63	1	U1	IC, WIDE INPUT AND OUTPUT DC/DC CONVERTER	LINEAR TECH. LTC3886IUKG#10E2-PBF-ES
64	1	U3	IC, SYNCHRONOUS STEP-DOWN CONVERTER	LINEAR TECH. LTC3630EMSE#PBF
65	1	U4	IC, 24LC05-I/ST	MICROCHIP 24LC025-I/ST
66	1	U5	IC, LTC6992	LINEAR TECH. LTC6992IS6-1
67	1	U6	IC, SINGLE OP AMP	LINEAR TECH. LT1803IS5

# DEMO MANUAL

## DC2155A-A/DC2155A-B

### PARTS LIST DC2155A-A

ITEM	QTY	REFERENCE	PART DESCRIPTION	MANUFACTURER/PART NUMBER
<b>DC2155A-A Additional Demo Board Circuit Components</b>				
1	0	C16, C17, C31, C32	CAP, 7343 OPTION	OPTION
2	0	C19, C35, C73	CAP, 0603 OPTION	OPTION
3	0	C71, C77	CAP, 0805 OPTION	OPTION
4	0	C75	CAP, 1210 OPTION	OPTION
5	0	C86, C87	CAP, ELEC OPTION	OPTION
6	0	D8	DIODE, ZENER OPTION	OPTION
7	0	D9, D12	DIODE, OPTION	OPTION
8	0	L1, L2	IND, 6.8 $\mu$ H OPTION	COILCRAFT SER2195H-682KL OPTION
9	0	L1, L2 - ALTERNATE	IND, 6.8 $\mu$ H OPTION	COILCRAFT SER2918H-682KL OPTION
10	0	Q2, Q4, Q5, Q8	XSTR, OPTION	OPTION
11	0	Q27	XSTR, N-CHANNEL DMOS FET OPTION	OPTION
12	0	R5, R6, R7, R8	RES, 2512 0 $\Omega$ JUMPER OPTION	RN5326 2512 TEPRO NAKOMA OPTION
13	0	R19, R20, R29, R31, R32, R33, R34, R35, R36, R39, R40, R41, R42, R46, R47, R48, R49, R97, R100, R101, R102, R103, R104, R105, R108, R110, R111, R116, R117, R118, R121, R144, R145, R147, R148, R169, R173	RES, 0603 OPTION	OPTION
14	0	R90, R92	RES, 0805 OPTION	OPTION
15	0	R107	RES, 1206 OPTION	OPTION
16	0	R163	RES, 1206 0 $\Omega$ JUMPER OPTION	VISHAY CRCW12060000Z0EA OPTION
<b>DC2155A-A Hardware: For Demo Board Only</b>				
1	25	E1, E2, E3, E4, E5, E6, E7, E8, E11, E12, E14, E16, E18, E20, E21, E22, E23, E24, E25, E26, E27, E29, E30, E32, E35, E36	TURRET	MILL-MAX 2501-2-00-80-00-00-07-0
2	5	JP1, JP2, JP3, JP5, JP6	HEADER, 3 PIN 2mm	SULLINS NRPN031PAEN-RC
3	6	J1, J2, J3, J4, J5, J6	STUD, TESTPIN	PEM KFH-032-10
4	2	J7, J12	CONN, BNC, 5 PINS	CONNEX 112404
5	1	J9	HEADER, 14PIN DUAL ROW R/A	MOLEX 87760-1416
6	1	J10	CONN, SOCKET 14PIN DUAL ROW R/A	SULLINSINC. NPPN072FJFN-RC
7	1	J11	HEADER, 12PIN 2mm STR DL	FCI 98414-G06-12ULF
8	10		LUG RING, #10	KEYSTONE 8205
9	4	MH1, MH2, MH3, MH4	STANDOFF, SNAP ON	KEYSTONE_8831
10	20		NUT, BRASS 10-32	ANY #10-32
11	2	SW1, SW2	SWITCH, SUBMINATURE SLIDE	C&K JS202011CQN
12	10		WASHER, #10 TIN PLATED BRASS	ANY #10 EXT BZ TN
13	5	XJP1, XJP2, XJP3, XJP5, XJP6	SHUNT	SAMTEC 2SN-BK-G



# DEMO MANUAL

## DC2155A-A/DC2155A-B

### PARTS LIST DC2155A-B

ITEM	QTY	REFERENCE	PART DESCRIPTION	MANUFACTURER/PART NUMBER
<b>DC2155A-B Required Circuit Components</b>				
1	2	C1, C85	CAP, 56µF 20% 63V ELEC	SUNCON 63HVP56M
2	6	C3, C9, C23, C44, C54, C60	CAP, 0603 0.1µF 10% 100V X7R	MURATA GRM188R72A104KA35J
3	2	C4, C5	CAP, 0603 10nF 10% 100V X7R	AVX 06031C103KAT2A
4	1	C6	CAP, 0603 1nF 10% 100V X7R	AVX 06031C102KAT2A
5	9	C7, C8, C21, C22, C41, C42, C58, C59, C74	CAP, 1210 2.2µF 10% 100V X7R	MURATA GRM32ER72A225KA35L
6	16	C10, C11, C12, C24, C25, C26, C46, C47, C48, C61, C62, C67, C88, C89, C90, C93	CAP, 1210 22µF 20% 16V X7R	MURATA GRM32ER71C226MEA8L
7	4	C13, C28, C55, C68	CAP, 0603 1nF 10% 16V X7R	AVX 0603YC102KAT2A
8	8	C14, C15, C29, C30, C50, C52, C63, C64	CAP, 150µF 16V ELEC. OS-CON	PANASONIC 16SVP150M
9	1	C18	CAP, 0603 8.2nF 10% 50V X7R	AVX 06035C822KAT2A
10	2	C20, C36	CAP, 0603 100pF 5% 50V C0G	AVX 06035A101JAT2A
11	4	C27, C33, C82, C83	CAP, 0603 10nF 10% 25V X7R	AVX 06033C103KAT2A
12	2	C37, C38	CAP, 0603 2.2µF 10% 16V X5R	AVX 0603YD225KAT2A
13	2	C39, C45	CAP, 0603 4.7µF 10% 10V X5R	AVX 0603ZD475KAT2A
14	2	C40, C43	CAP, 0603 4.7µF 10% 16V X5R	MURATA GRM188R61C475KAAJD
15	2	C49, C57	CAP, 0603 10pF 5% 50V C0G	AVX 06035A100JAT2A
16	2	C70, C103	CAP, 0805 2.2µF 10% 16V X7R	AVX 0805YC225KAT2A
17	1	C72	CAP, 0603 47nF 10% 25V X7R	AVX 06033C473KAT2A
18	1	C76	CAP, 0603 0.1µF 10% 25V X7R	AVX 06033C104KAT2A
19	1	C78	CAP, 0805 220nF 10% 100V X7R	MURATA GRM21AR72A224KAC5L
20	2	C79, C80	CAP, 1210 100µF 20% 10V X5R	TAIYO YUDEN LMK325ABJ107MM-T
21	1	C81	CAP, 0603 220pF 10% 50V X7R	AVX 06035C221KAT2A
22	2	C84, C101	CAP, 0603 100nF 20% 16V X7R	AVX 0603YC104MAT2A
23	2	C94, C95	CAP, 1812 10µF 20% 100V X7S	TDK CKG45NX7S2A106M500JH
24	4	C96, C97, C98, C99	CAP, 1206 2.2µF 10% 100V X7R	MURATA GRM31CR72A225KA73L
25	1	C100	CAP, 0603 150pF 5% 50V NPO	AVX 06035A151JAT2A
26	1	C102	CAP, 0603 1µF 20% 25V X5R	AVX 06033D105MAT2A
27	4	D1, D2, D3, D4	DIODE, SCHOTTKY 100V, 1A	DIODES/ZETEX, DFLS1100-7
28	4	D5, D6, D13, D14	LED, 0603 GREEN	OSRAM LG L29K-G2J1-24-Z
29	1	D7	LED, 0603 RED	OSRAM LS L29K-H1J2-1-Z
30	4	L1, L2, L3, L4	IND, 8.6µH	WURTH ELEKTRONIK 7443630860
31	1	L5	IND, 68µH	SUMIDA CDRH105RNP-680NC
32	4	Q1, Q6, Q11, Q15	XSTR, MOSFET N-CH 60V 25A 5 PIN LPAK	RENESAS RJK0651DPB
33	4	Q3, Q7, Q13, Q18	XSTR, MOSFET N-CH 60V 45A 5 PIN LPAK	RENESAS RJK0653DPB
34	2	Q9, Q10	XSTR, PNP GENERAL PURPOSE SOT-323	DIODES INC. MMST3906-7-F
35	1	Q19	XSTR, MOSFET N-CH 30V 30A 5 PIN LPAK	RENESAS RJK0305DPB-00#JO
36	1	Q20	XSTR, MOSFET P-CH 20V 5.2A SOT-23	VISHAY Si2365EDS-T1-GE3

# DEMO MANUAL

## DC2155A-A/DC2155A-B

### PARTS LIST DC2155A-B

ITEM	QTY	REFERENCE	PART DESCRIPTION	MANUFACTURER/PART NUMBER
37	4	Q22, Q23, Q28, Q29	XSTR, MOSFET N-CH 60V 115mA SOT-23	FAIRCHILD 2N7002A
38	2	R2, R122	RES, 2512 0.003Ω 1% 1W	PANASONIC ERJ-M1WTF3MOU
39	2	R3, R4	RES, 0603 1k 5% 1/10W	VISHAY CRCW06031K00JNEA
40	6	R5, R6, R7, R8, R124, R125	RES, 2512 0Ω JUMPER	VISHAY CRCW25120000Z0EG
41	7	R9, R12, R30, R38, R52, R53, R67	RES, 0603 2Ω 5% 1/10W	VISHAY CRCW06032R00JNEA
42	12	R10, R11, R13, R15, R16, R18, R23, R25, R28, R89, R112, R113	RES, 0603 10k 5% 1/10W	VISHAY CRCW060310K0JNEA
43	4	R14, R37, R58, R70	RES, 2010 3mΩ 1% 1/2W	VISHAY WSL20103L000FEA
44	36	R17, R21, R22, R27, R43, R44, R45, R56, R57, R59, R60, R61, R62, R64, R66, R69, R73, R74, R78, R80, R81, R96, R98, R106, R109, R118, R121, R128, R129, R130, R131, R132, R148, R168, R173, R174	RES, 0603 0Ω JUMPER	VISHAY CRCW06030000Z0EA
45	9	R24, R26, R50, R51, R63, R65, R75, R76, R155	RES, 0603 100Ω 5% 1/10W	VISHAY CRCW0603100RJNEA
46	2	R68, R158	RES, 0603 49.9k 1% 1/10W	VISHAY CRCW060349K9FKEA
47	4	R87, R88, R171, R172	RES, 0603 200Ω 5% 1/10W	VISHAY CRCW0603200RJNEA
48	1	R91	RES, 2010 0.01Ω 1% 1/2W	VISHAY WSL2010R0100FEA
49	1	R93	RES, 0603 127Ω 1% 1/10W	VISHAY CRCW0603127RFKEA
50	1	R99	RES, 0603 220k 5% 1/10W	VISHAY CRCW0603220KJNEA
51	2	R114, R115	RES, 0603 10Ω 5% 1/10W	VISHAY CRCW060310R0JNEA
52	2	R119, R120	RES, 0603 4.99k 1% 1/10W	VISHAY CRCW06034K99FKEA
53	1	R146	RES, 0805 4.7Ω 1% 0.125W	VISHAY CRCW08054R70FKEA
54	1	R151	RES, 0603 1M 5% 1/10W	VISHAY CRCW06031M00JNEA
55	1	R152	RES, 0603 681k 1% 1/10W	VISHAY CRCW0603681KFKEA
56	1	R153	RES, 0603 3.3Ω 1% 1/10W	VISHAY CRCW06033R30FKEA
57	1	R154	RES, 0603 82.5Ω 1% 1/10W	VISHAY CRCW060382R5FKEA
58	1	R157	RES, 0603 2Ω 5% 1/10W	VISHAY CRCW06032R00JNEA
59	1	R158	RES, 0603 27.4k 1% 1/10W	VISHAY CRCW060327K4FKEA
60	1	R159	RES, 0603 226k 1% 1/10W	VISHAY CRCW0603226KFKEA
61	1	R160	RES, VARIABLE 5k	BOURNS 3386P-1-502-LF
62	1	R161	RES, 0603 20k 5% 1/10W	VISHAY CRCW060320K0JNEA
63	2	R162, R163	RES, 1206 0Ω JUMPER	VISHAY CRCW12060000Z0EA
64	1	R170	RES, 0603 340Ω 5% 1/10W	VISHAY CRCW0603340RJNEA
65	1	U1	IC, WIDE INPUT AND OUTPUT DC/DC CONVERTER	LINEAR TECH. LTC3886IUKG#10E3-1PBF-ES
66	1	U2	IC, POLYPHASE STEP-DOWN SLAVE CONTROLLER	LINEAR TECH. LTC3870EUFDF#PBF
67	1	U3	IC, SYNCHRONOUS STEP-DOWN CONVERTER	LINEAR TECH. LTC3630EMSE#PBF
68	1	U4	IC, 24LC05-I/ST	MICROCHIP 24LC025-I/ST
69	1	U5	IC, LTC6992	LINEAR TECH. LTC6992IS6-1
70	1	U6	IC, SINGLE OP AMP	LINEAR TECH. LT1803IS5



# DEMO MANUAL

## DC2155A-A/DC2155A-B

### PARTS LIST DC2155A-B

ITEM	QTY	REFERENCE	PART DESCRIPTION	MANUFACTURER/PART NUMBER
<b>DC2155A-B Additional Demo Board Circuit Components</b>				
1	0	C16, C17, C31, C32, C51, C53, C65, C66	CAP, 7343 OPTION	OPTION
2	0	C19, C34, C35, C56, C69, C73	CAP, 0603 OPTION	OPTION
3	0	C71, C77, C91, C92	CAP, 0805 OPTION	OPTION
4	0	C75	CAP, 1210 OPTION	OPTION
5	0	C86, C87	CAP, ELEC OPTION	OPTION
6	0	D8	DIODE, ZENER OPTION	OPTION
7	0	D9, D12	DIODE, OPTION	OPTION
8	0	L1, L2, L3, L4	IND, 6.8μH OPTION	COILCRAFT SER2915-682KL OPTION
9	0	L1, L2, L3, L4 - ALTERNATE	IND, 6.8μH OPTION	COILCRAFT SER2918H-682KL OPTION
10	0	Q2, Q4, Q5, Q8, Q12, Q14, Q16, Q17	XSTR, OPTION	OPTION
11	0	Q27	XSTR, N-CHANNEL DMOS FET OPTION	OPTION
12	0	R19, R20, R29, R31, R32, R33, R34, R35, R36, R39, R40, R41, R42, R46, R47, R48, R49, R54, R55, R71, R72, R77, R79, R82, R83, R97, R100, R101, R102, R103, R104, R105, R108, R110, R111, R116, R117, R144, R145, R147, R169	RES, 0603 OPTION	OPTION
13	0	R90, R92, R94, R95	RES, 0805 OPTION	OPTION
13	0	R107	RES, 1206 OPTION	OPTION
<b>DC2155A-B Hardware: For Demo Board Only</b>				
1	26	E1, E2, E3, E4, E5, E6, E7, E8, E11, E12, E14, E16, E18, E20, E21, E22, E23, E24, E25, E26, E27, E29, E30, E32, E35, E36	TURRET	MILL-MAX 2501-2-00-80-00-00-07-0
2	5	JP1, JP2, JP3, JP5, JP6	HEADER, 3 PIN 2mm	SULLINS NRPN031PAEN-RC
3	6	J1, J2, J3, J4, J5, J6	STUD, TESTPIN	PEM KFH-032-10
4	2	J7, J12	CONN, BNC, 5 PINS	CONNEX 112404
5	1	J9	HEADER, 14PIN DUAL ROW R/A	MOLEX 87760-1416
6	1	J10	CONN, SOCKET 14PIN DUAL ROW R/A	SULLINSINC. NPPN072FJFN-RC
7	1	J11	HEADER, 12PIN 2mm STR DL	FCI 98414-G06-12ULF
8	10		LUG RING, #10	KEYSTONE 8205
9	4	MH1, MH2, MH3, MH4	STANDOFF, SNAP ON	KEYSTONE_8831
10	20		NUT, BRASS 10-32	ANY #10-32
11	2	SW1, SW2	SWITCH, SUBMINATURE SLIDE	C&K JS202011CQN
12	10		WASHER, #10 TIN PLATED BRASS	ANY #10 EXT BZ TN
13	5	XJP1, XJP2, XJP3, XJP5, XJP6	SHUNT	SAMTEC 2SN-BK-G

# DEMO MANUAL DC2155A-A/DC2155A-B

## SCHEMATIC DIAGRAM

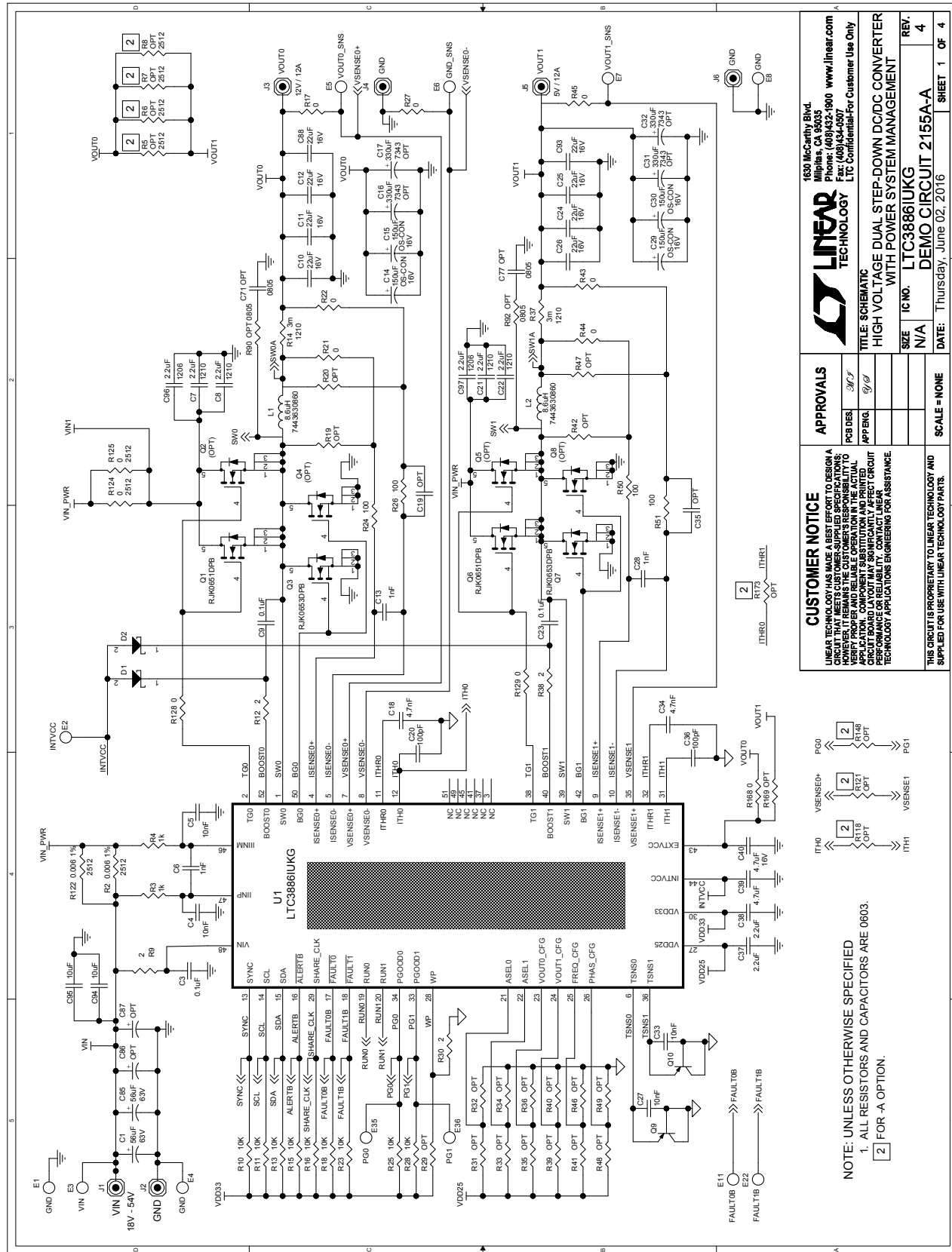

**LINEAR TECHNOLOGY**  
1630 McCarthy Blvd.  
Milpitas, CA 95035  
Phone: (408)432-1900 www.linear.com  
Fax: (408)434-0307  
LTC Confidential-For Customer Use Only

**APPROVALS**

POB DES	3/CT
APP ENG	9/ed

**TITLE: SCHEMATIC**  
**HIGH VOLTAGE DUAL STEP-DOWN DC/DC CONVERTER WITH POWER SYSTEM MANAGEMENT**

SIZE	IC NO.	LTC3886IUKG	REV.
N/A		DEMO CIRCUIT 2155A-A	4
DATE:	Thursday, June 02, 2016		SHEET 1 OF 4

**CUSTOMER NOTICE**  
LINEAR TECHNOLOGY HAS MADE A BEST EFFORT TO DESIGN A CIRCUIT THAT MEETS CUSTOMER-SUPPLIED SPECIFICATIONS. THE USER MUST VERIFY PROPER AND RELIABLE OPERATION IN THE ACTUAL APPLICATION. COMPONENT SUBSTITUTION AND PRINTED CIRCUIT BOARD MANUFACTURING VARIATIONS MAY AFFECT PERFORMANCE OR RELIABILITY. CONTACT LINEAR TECHNOLOGY APPLICATIONS ENGINEERING FOR ASSISTANCE.

**THIS CIRCUIT IS PROPRIETARY TO LINEAR TECHNOLOGY AND SUPPLIED FOR USE WITH LINEAR TECHNOLOGY PARTS.**

**NOTE: UNLESS OTHERWISE SPECIFIED**  
1. ALL RESISTORS AND CAPACITORS ARE 0603.

[2] FOR A OPTION.

Figure 15a. DC2155A-A Demo Circuit Schematic, Sheet 1

## SCHEMATIC DIAGRAM

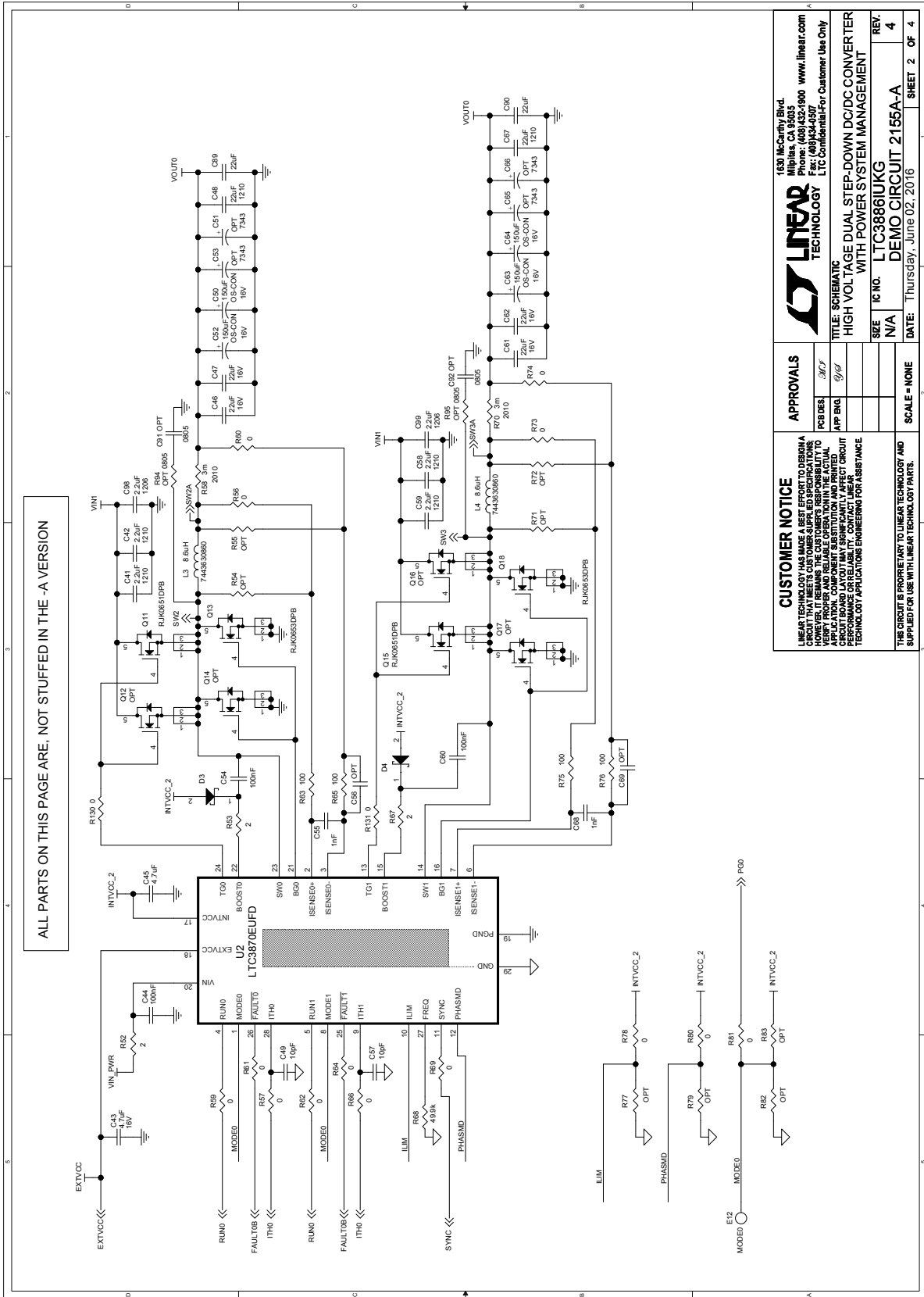

**CUSTOMER NOTICE**  
LINEAR TECHNOLOGY HAS MADE A BEST EFFORT TO DESIGN A CIRCUIT THAT MEETS CUSTOMER-SUPPLIED SPECIFICATIONS FOR THE DEMO. THE USER MUST VERIFY THE RESULTS TO CONFIRM THE CIRCUIT MEETS THE SPECIFICATIONS FOR THE INTENDED APPLICATION. COMPONENT SUBSTITUTION AND PRINTED CIRCUIT BOARD MANUFACTURING VARIATIONS MAY AFFECT CIRCUIT PERFORMANCE OR RELIABILITY. CONTACT LINEAR TECHNOLOGY APPLICATIONS ENGINEERING FOR ASSISTANCE.

**APPROVALS**

PCB DES.	3/07
APP ENG	9/08

**1639 McCarty Blvd.**  
**Linear Technology**  
 Phone: (408) 432-8900 www.linear.com  
 Fax: (408) 434-9007  
 LTC Confidential-For Customer Use Only

**LINEAR TECHNOLOGY**

**TITLE: SCHEMATIC**  
**WITH POWER SYSTEM MANAGEMENT**  
**HIGH VOLTAGE DUAL STEP-DOWN DC/DC CONVERTER**

SIZE	IC NO.	REV.
N/A	LTC3886IUKG	4
DATE:	Thursday, June 02, 2016	SHEET 2 OF 4

**DEMO CIRCUIT 2155A-A**

THIS CIRCUIT IS PROPRIETARY TO LINEAR TECHNOLOGY AND SUPPLIED FOR USE WITH LINEAR TECHNOLOGY PARTS. SCALE = NONE

Figure 15b. DC2155A-A Demo Circuit Schematic, Sheet 2

# DEMO MANUAL DC2155A-A/DC2155A-B

## SCHEMATIC DIAGRAM

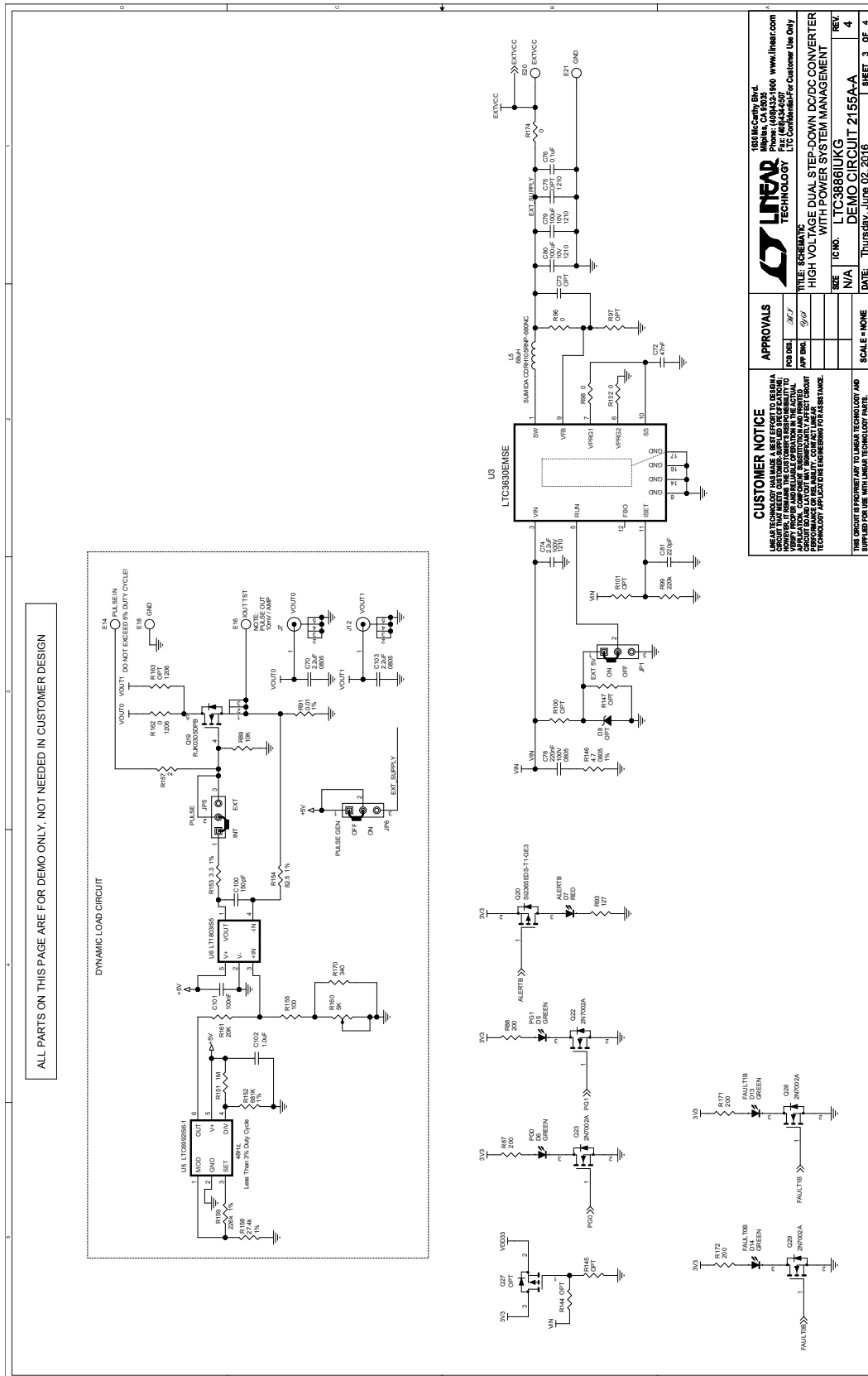

Figure 15c. DC2155A-A Demo Circuit Schematic, Sheet 3

## SCHEMATIC DIAGRAM

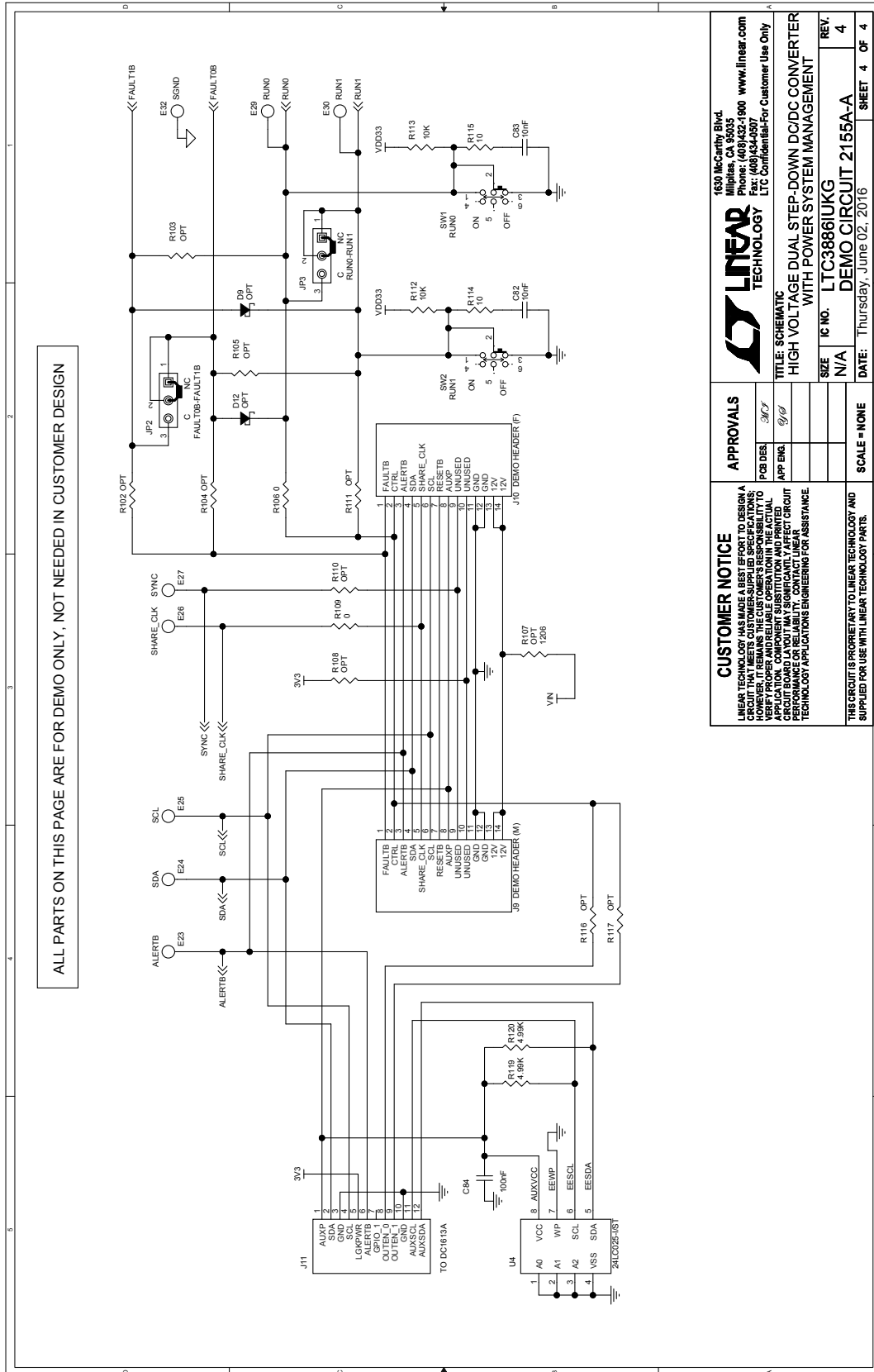
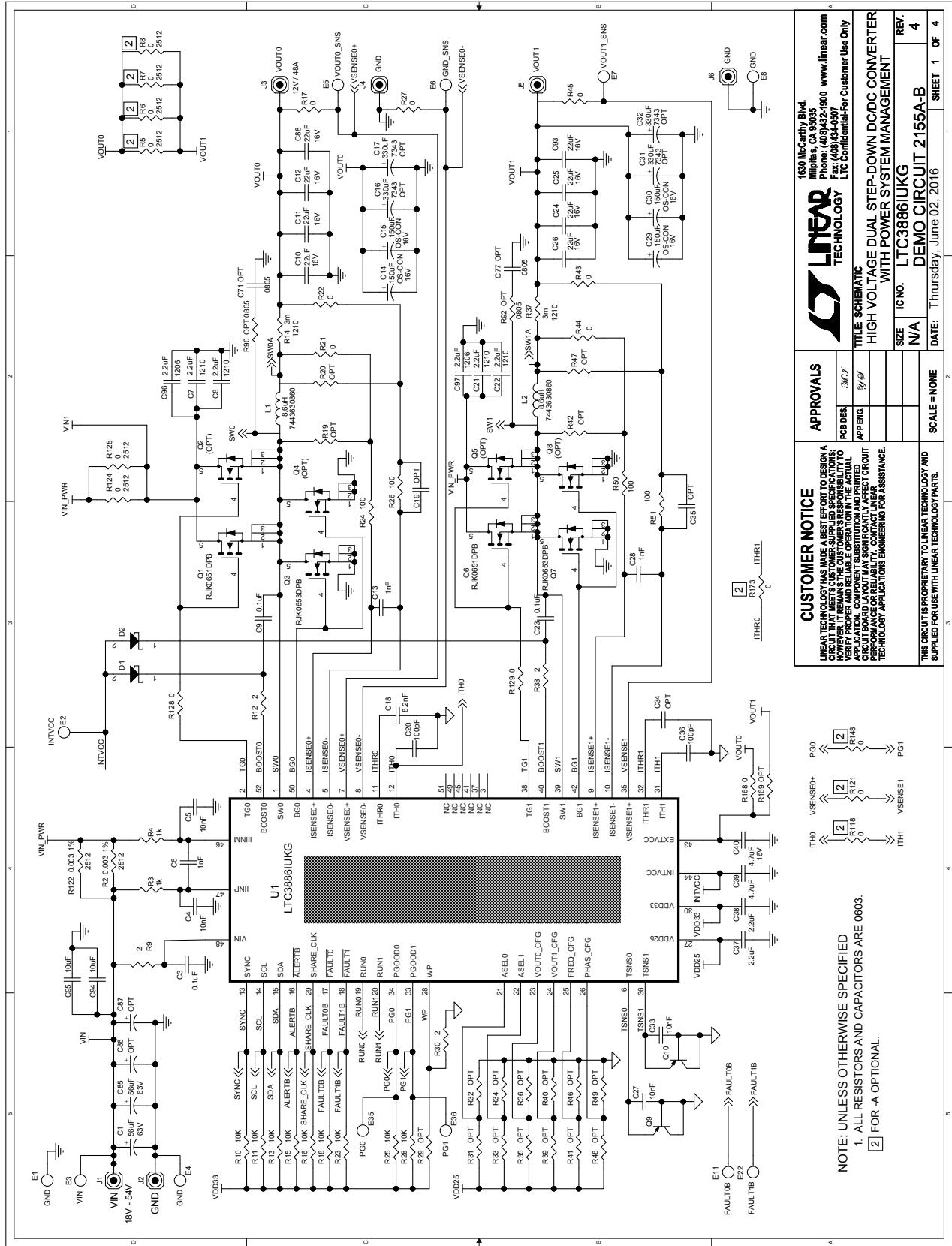

Figure 15d. DC2155A-A Demo Circuit Schematic, Sheet 4

# DEMO MANUAL

## DC2155A-A/DC2155A-B

### SCHEMATIC DIAGRAM



**LINEAR TECHNOLOGY**  
 1630 McCarthy Blvd.  
 Milpitas, CA 95035  
 Phone: (408)432-1900 www.linear.com  
 Fax: (408)434-0307  
 LTC Confidential-For Customer Use Only

**TITLE: SCHEMATIC**  
**WITH POWER SYSTEM MANAGEMENT**  
**HIGH VOLTAGE DUAL STEP-DOWN DC/DC CONVERTER**

**SIZE** IC NO. **LTC3886IUKG** **REV.** **4**  
**N/A** **DATE:** Thursday, June 02, 2016 **SHEET 1 OF 4**

**APPROVALS**

POB DES	3/CT
APP ENG	9/ed

**CUSTOMER NOTICE**  
 LINEAR TECHNOLOGY HAS MADE A BEST EFFORT TO DESIGN A CIRCUIT THAT MEETS CUSTOMER-SUPPLIED SPECIFICATIONS. CUSTOMERS ARE RESPONSIBLE FOR VERIFYING THE OPERATION OF THE ACTUAL APPLICATION. COMPONENT SUBSTITUTION AND PRINTED BOARD MANUFACTURING VARIATIONS MAY AFFECT CIRCUIT PERFORMANCE OR RELIABILITY. CONTACT LINEAR TECHNOLOGY APPLICATIONS ENGINEERING FOR ASSISTANCE.

**THIS CIRCUIT IS PROPRIETARY TO LINEAR TECHNOLOGY AND SUPPLIED FOR USE WITH LINEAR TECHNOLOGY PARTS.**

**NOTE: UNLESS OTHERWISE SPECIFIED**  
 1. ALL RESISTORS AND CAPACITORS ARE 0603.  
 [2] FOR A OPTIONAL.

PG0  
 VSENSE+  
 ITH0  
 ITH1  
 VSENSE1  
 PG1

Figure 16a. DC2155A-B Demo Circuit Schematic, Sheet 1

## SCHEMATIC DIAGRAM

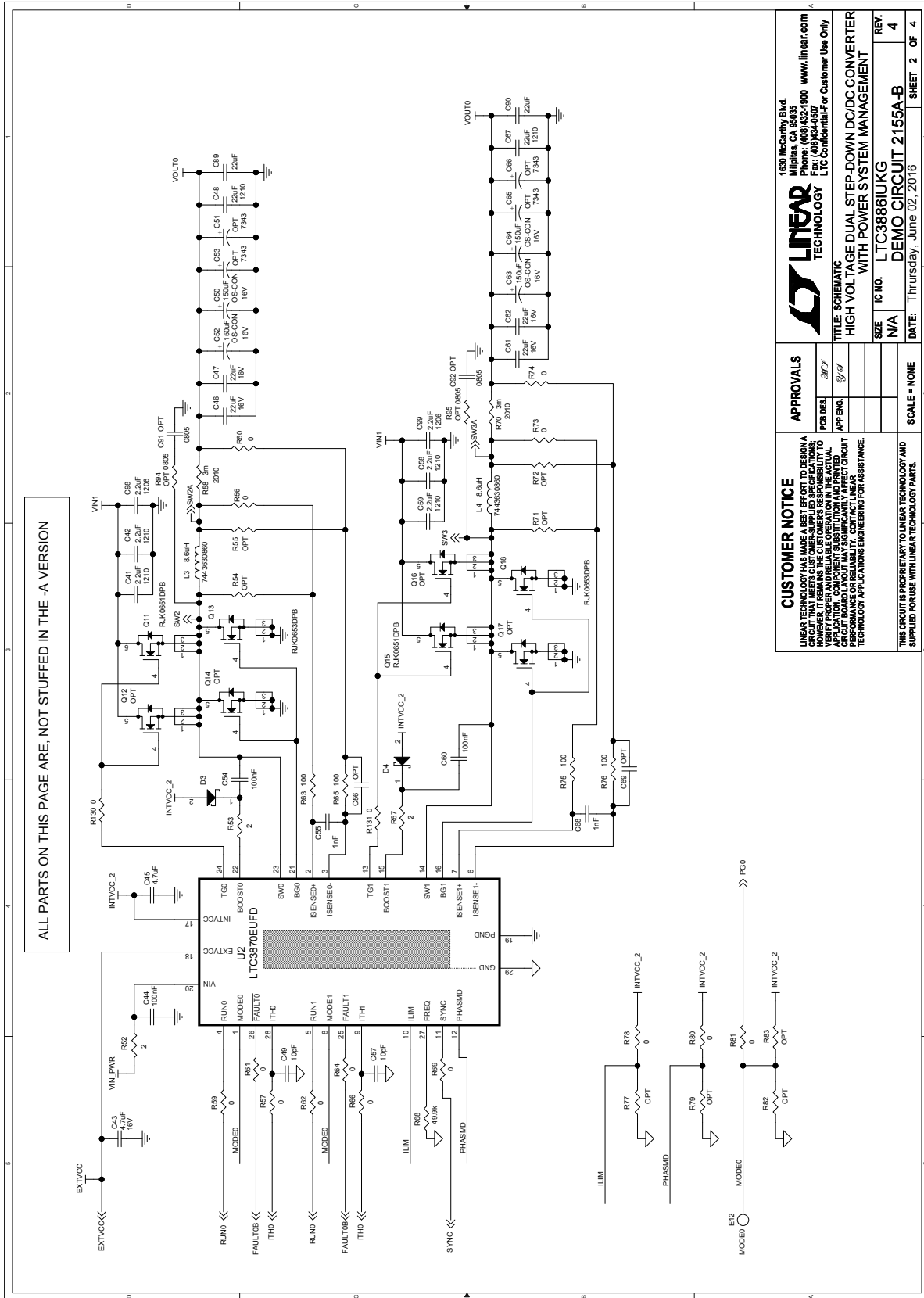

Figure 16b. DC2155A-B Demo Circuit Schematic, Sheet 2

# DEMO MANUAL DC2155A-A/DC2155A-B

## SCHEMATIC DIAGRAM

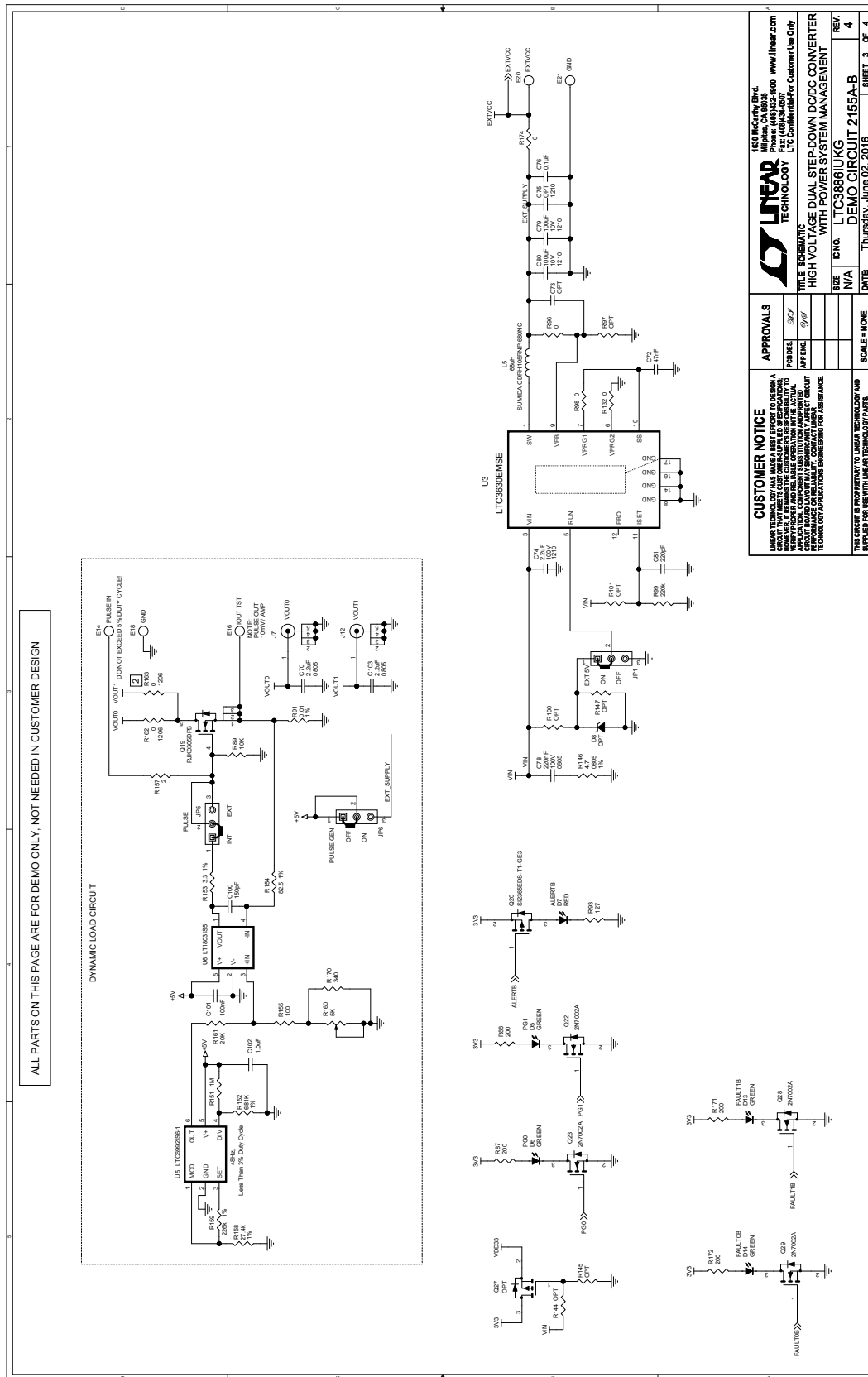

Figure 16c. DC2155A-B Demo Circuit Schematic, Sheet 3



## SCHEMATIC DIAGRAM

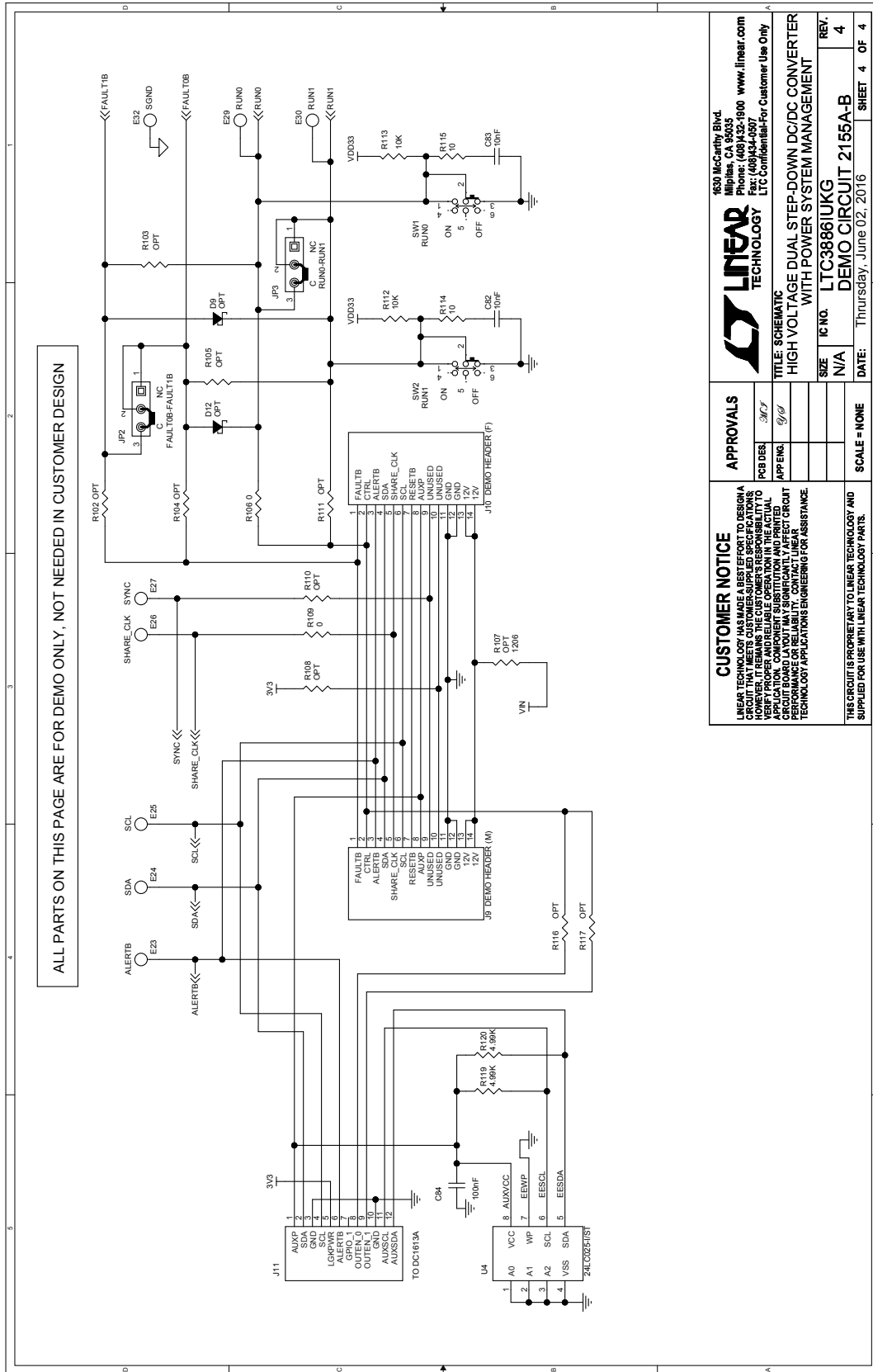

Figure 16d. DC2155A-B Demo Circuit Schematic, Sheet 4

# DEMO MANUAL

## DC2155A-A/DC2155A-B

---

### DEMONSTRATION BOARD IMPORTANT NOTICE

Linear Technology Corporation (LTC) provides the enclosed product(s) under the following **AS IS** conditions:

This demonstration board (DEMO BOARD) kit being sold or provided by Linear Technology is intended for use for **ENGINEERING DEVELOPMENT OR EVALUATION PURPOSES ONLY** and is not provided by LTC for commercial use. As such, the DEMO BOARD herein may not be complete in terms of required design-, marketing-, and/or manufacturing-related protective considerations, including but not limited to product safety measures typically found in finished commercial goods. As a prototype, this product does not fall within the scope of the European Union directive on electromagnetic compatibility and therefore may or may not meet the technical requirements of the directive, or other regulations.

If this evaluation kit does not meet the specifications recited in the DEMO BOARD manual the kit may be returned within 30 days from the date of delivery for a full refund. **THE FOREGOING WARRANTY IS THE EXCLUSIVE WARRANTY MADE BY THE SELLER TO BUYER AND IS IN LIEU OF ALL OTHER WARRANTIES, EXPRESSED, IMPLIED, OR STATUTORY, INCLUDING ANY WARRANTY OF MERCHANTABILITY OR FITNESS FOR ANY PARTICULAR PURPOSE. EXCEPT TO THE EXTENT OF THIS INDEMNITY, NEITHER PARTY SHALL BE LIABLE TO THE OTHER FOR ANY INDIRECT, SPECIAL, INCIDENTAL, OR CONSEQUENTIAL DAMAGES.**

The user assumes all responsibility and liability for proper and safe handling of the goods. Further, the user releases LTC from all claims arising from the handling or use of the goods. Due to the open construction of the product, it is the user's responsibility to take any and all appropriate precautions with regard to electrostatic discharge. Also be aware that the products herein may not be regulatory compliant or agency certified (FCC, UL, CE, etc.).

No License is granted under any patent right or other intellectual property whatsoever. **LTC assumes no liability for applications assistance, customer product design, software performance, or infringement of patents or any other intellectual property rights of any kind.**

LTC currently services a variety of customers for products around the world, and therefore this transaction **is not exclusive**.

**Please read the DEMO BOARD manual prior to handling the product.** Persons handling this product must have electronics training and observe good laboratory practice standards. **Common sense is encouraged.**

This notice contains important safety information about temperatures and voltages. For further safety concerns, please contact a LTC application engineer.

Mailing Address:

Linear Technology  
1630 McCarthy Blvd.  
Milpitas, CA 95035

Copyright © 2004, Linear Technology Corporation