

# Dual, 2-Phase Synchronous DC/DC Controller with Pin Selectable Outputs

## FEATURES

- Dual, 180° Phased Controllers
- 2-Pin VID Output Voltage Programming from 0.6V to 5V
- High Efficiency: Up to 95%
- $R_{SENSE}$  or DCR Current Sensing
- Phase-Lockable Fixed Frequency 250kHz to 770kHz
- Adjustable Current Limit
- Dual N-Channel MOSFET Synchronous Drive
- Wide  $V_{IN}$  Range: 4.5V to 38V Operation
- Adjustable Soft-Start Current Ramping or Tracking
- Output OV Protection With Reverse Current Limit
- Power Good Output Voltage Monitor
- 32-Pin 5mm × 5mm QFN and 38-Lead TSSOP Packages

## APPLICATIONS

- DC Power Distribution Systems

LT, LT, LTC, LTM, Burst Mode, OPTI-LOOP  $\mu$ Module, Linear Technology and the Linear logo are registered trademarks and No  $R_{SENSE}$  is a trademark of Linear Technology Corporation. All other trademarks are the property of their respective owners. U.S. Patents, including 5481178, 5705919, 5929620, 6100678, 6144194, 6177787, 6304066, 6580258.

## DESCRIPTION

The LTC<sup>®</sup>3865/LTC3865-1 are high performance dual synchronous step-down DC/DC switching regulator controllers that drive all N-channel synchronous power MOSFET stages. A constant frequency current mode architecture allows a phase-lockable frequency of up to 770kHz. Power loss and noise are minimized by operating the two controller output stages out of phase.

OPTI-LOOP<sup>®</sup> compensation allows the transient response to be optimized over a wide range of output capacitance and ESR values. Independent track/soft-start pins for each controller ramp the output voltage during start-up. Current foldback limits MOSFET heat dissipation during short-circuit conditions. The MODE/PLLIN pin selects among Burst Mode<sup>®</sup> operation, pulse-skipping mode, and continuous inductor current mode. The output voltages can be precisely programmed by pin strapping or external resistors.

The LTC3865/LTC3865-1 are available in low profile (5mm × 5mm) 32-pin QFN and 38-Lead thermally enhanced TSSOP packages.

## TYPICAL APPLICATION

High Efficiency 1.5V/15A, 1.2V/15A Step-Down Converter

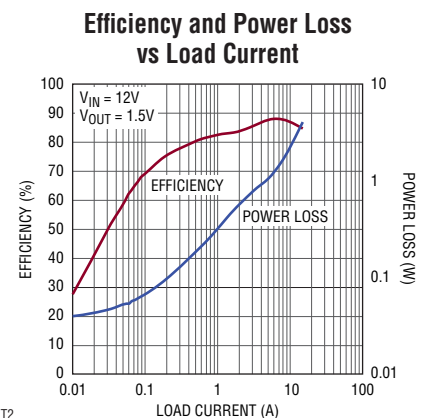
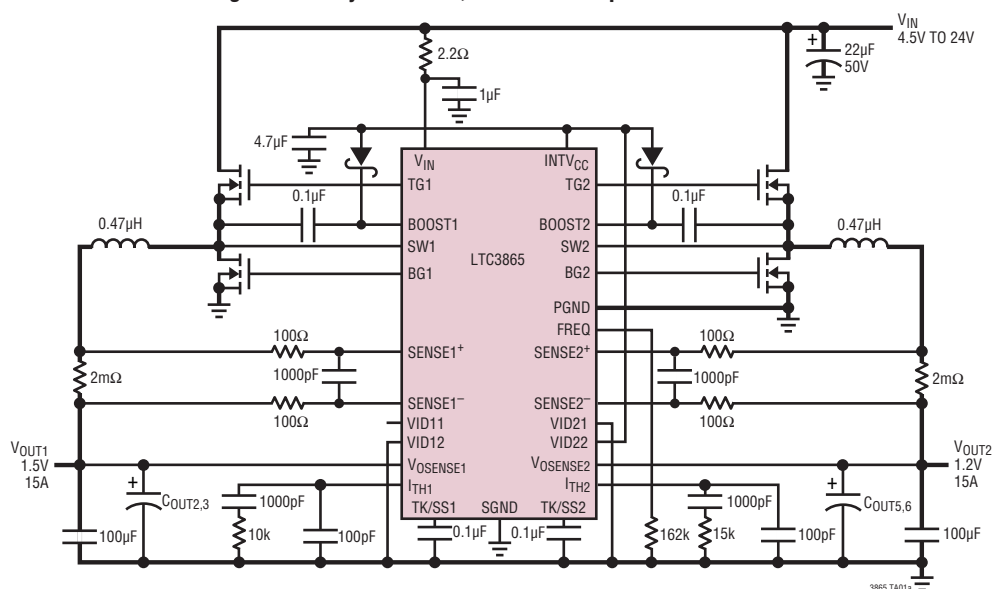

# LTC3865/LTC3865-1

## ABSOLUTE MAXIMUM RATINGS (Note 1)

Input Supply Voltage ( $V_{IN}$ ) ..... -0.3V to 40V  
 Topside Driver Voltages  
     BOOST1, BOOST2 ..... -0.3V to 46V  
 Switch Voltage (SW1, SW2) ..... -5V to 40V  
 $INTV_{CC}$ , RUN1, RUN2, PGOOD(s),  $EXTV_{CC}$ ,  
 (BOOST1-SW1), (BOOST2-SW2) ..... -0.3V to 6V  
 $SENSE1^+$ ,  $SENSE2^+$ ,  $SENSE1^-$ ,  $SENSE2^-$   
 $V_{OSENSE1}$ ,  $V_{OSENSE2}$  Voltages ..... -0.3V to 5.8V  
 MODE/PLLIN,  $I_{LIM}$ , TK/SS1, TK/SS2, VID11,  
 VID12, VID21, VID22, FREQ Voltages ... -0.3V to  $INTV_{CC}$

$I_{TH1}$ ,  $I_{TH2}$  Voltages ..... -0.3V to 2.7V  
 $INTV_{CC}$  DC Output Current ..... 80mA  
 Operating Junction Temperature Range (Notes 2, 3)  
     LTC3865/LTC3865-1 ..... -40°C to 125°C  
 Storage Temperature Range ..... -65°C to 125°C  
 Lead Temperature (Soldering, 10 sec)  
     FE Package ..... 300°C

## PIN CONFIGURATION

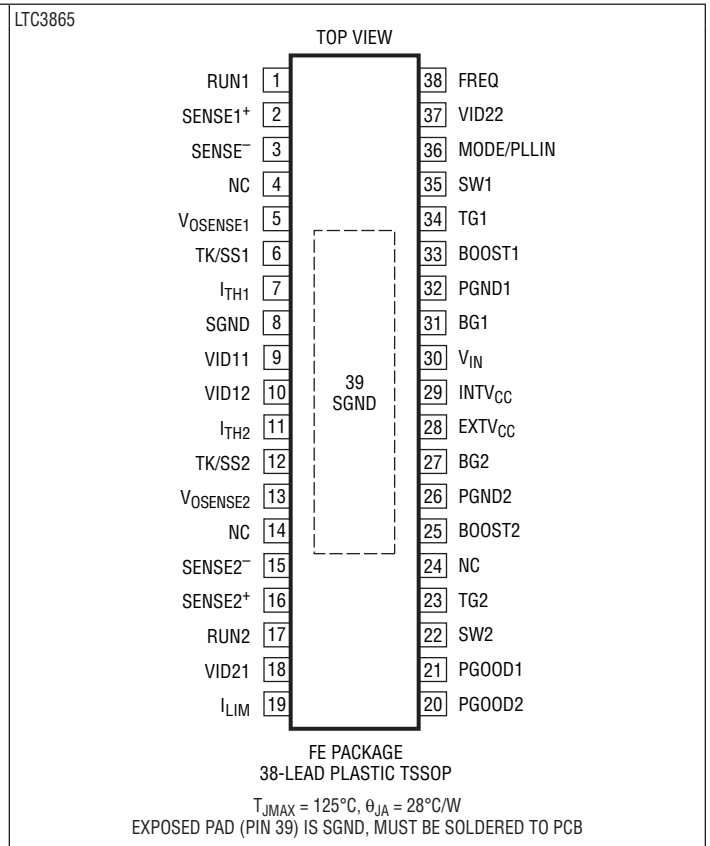
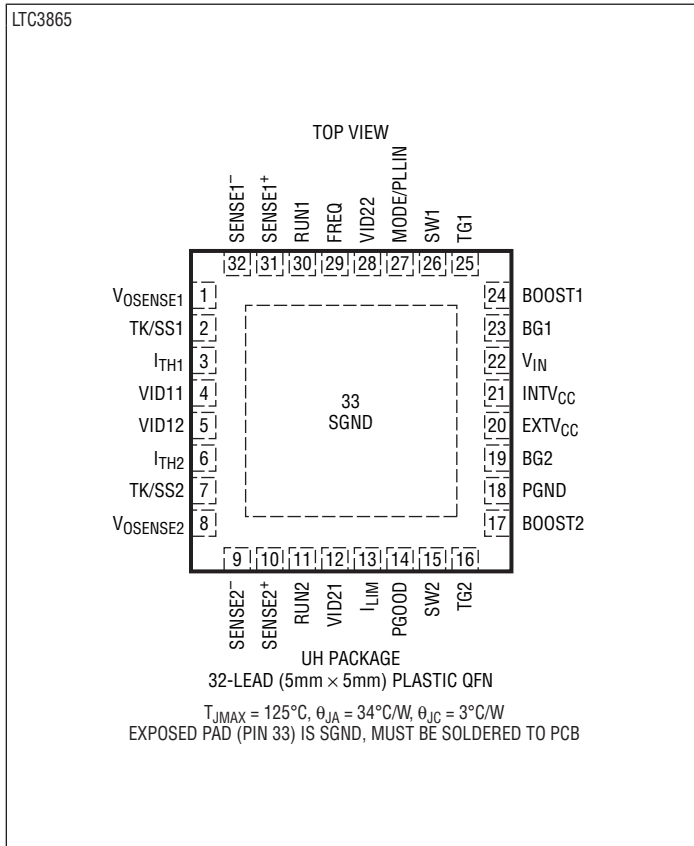

## PIN CONFIGURATION

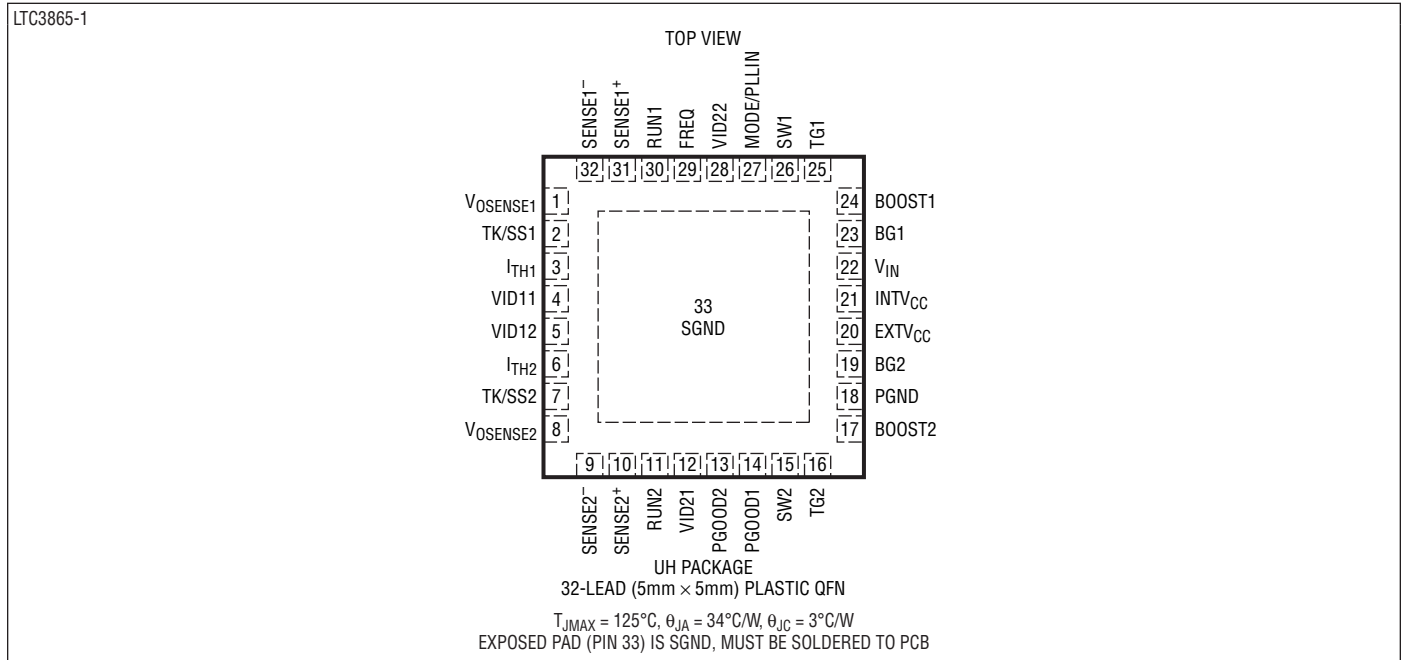

## ORDER INFORMATION

LEAD FREE FINISH	TAPE AND REEL	PART MARKING*	PACKAGE DESCRIPTION	TEMPERATURE RANGE
LTC3865EUH#PBF	LTC3865EUH#TRPBF	3865	32-Lead (5mm × 5mm) Plastic QFN	-40°C to 85°C
LTC3865EUH-1#PBF	LTC3865EUH-1#TRPBF	38651	32-Lead (5mm × 5mm) Plastic QFN	-40°C to 85°C
LTC3865IUH#PBF	LTC3865IUH#TRPBF	3865	32-Lead (5mm × 5mm) Plastic QFN	-40°C to 125°C
LTC3865IUH-1#PBF	LTC3865IUH-1#TRPBF	38651	32-Lead (5mm × 5mm) Plastic QFN	-40°C to 125°C
LTC3865EFE#PBF	LTC3865EFE#TRPBF	LTC3865FE	38-Lead Plastic TSSOP	-40°C to 85°C
LTC3865IFE#PBF	LTC3865IFE#TRPBF	LTC3865FE	38-Lead Plastic TSSOP	-40°C to 125°C

Consult LTC Marketing for parts specified with wider operating temperature ranges. \*The temperature grade is identified by a label on the shipping container. Consult LTC Marketing for information on non-standard lead based finish parts.

For more information on lead free part marking, go to: <http://www.linear.com/leadfree/>

For more information on tape and reel specifications, go to: <http://www.linear.com/tapeandreeel/>

# LTC3865/LTC3865-1

## ELECTRICAL CHARACTERISTICS

The ● denotes the specifications which apply over the full operating junction temperature range, otherwise specifications are at  $T_J = 25^\circ\text{C}$ .  $V_{IN} = 15\text{V}$ ,  $V_{RUN1,2} = 5\text{V}$  unless otherwise noted.

SYMBOL	PARAMETER	CONDITIONS	MIN	TYP	MAX	UNITS	
<b>Main Control Loops</b>							
$V_{IN}$	Input Voltage		4.5		38	V	
$V_{OSENSE1,2}$	Output Voltage Sensing (E-Grade)	(Note 4) $I_{TH1,2}$ Voltage = 1.2V	●	1.089	1.100	1.111	V
		VID11 = VID21 = GND, VID12 = VID22 = GND	●	0.990	1.000	1.010	V
		VID11 = VID21 = GND, VID12 = VID22 = Float	●	1.188	1.200	1.212	V
		VID11 = VID21 = GND, VID12 = VID22 = INTV <sub>CC</sub>	●	1.485	1.500	1.515	V
		VID11 = VID21 = Float, VID12 = VID22 = GND	●	0.596	0.602	0.608	V
		VID11 = VID21 = Float, VID12 = VID22 = Float	●	1.782	1.800	1.818	V
		VID11 = VID21 = Float, VID12 = VID22 = INTV <sub>CC</sub>	●	2.463	2.500	2.538	V
		VID11 = VID21 = INTV <sub>CC</sub> , VID12 = VID22 = GND	●	3.251	3.300	3.350	V
	Output Voltage Sensing (I-Grade)	(Note 4) $I_{TH1,2}$ Voltage = 1.2V	●	1.084	1.100	1.117	V
		VID11 = VID21 = GND, VID12 = VID22 = GND	●	0.985	1.000	1.015	V
		VID11 = VID21 = GND, VID12 = VID22 = Float	●	1.182	1.200	1.218	V
		VID11 = VID21 = GND, VID12 = VID22 = INTV <sub>CC</sub>	●	1.478	1.500	1.523	V
		VID11 = VID21 = Float, VID12 = VID22 = GND	●	0.593	0.602	0.611	V
		VID11 = VID21 = Float, VID12 = VID22 = Float	●	1.773	1.800	1.827	V
		VID11 = VID21 = Float, VID12 = VID22 = INTV <sub>CC</sub>	●	2.450	2.500	2.550	V
		VID11 = VID21 = INTV <sub>CC</sub> , VID12 = VID22 = GND	●	3.234	3.300	3.366	V
VID11 = VID21 = INTV <sub>CC</sub> , VID12 = VID22 = Float	●	4.900	5.000	5.100	V		
VID11 = VID21 = INTV <sub>CC</sub> , VID12 = VID22 = INTV <sub>CC</sub>							
$I_{OSENSE1,2}$	Feedback Current	(Note 4) VID11 = VID21 = VID12 = VID22 = Float		-10	-50	nA	
$V_{REFLNREG}$	Reference Voltage Line Regulation	$V_{IN} = 4.5\text{V}$ to $38\text{V}$ (Note 4)		0.002	0.02	%/V	
$V_{LOADREG}$	Output Voltage Load Regulation	(Note 4) Measured in Servo Loop; $\Delta I_{TH}$ Voltage = 1.2V to 0.7V Measured in Servo Loop; $\Delta I_{TH}$ Voltage = 1.2V to 1.6V	●	0.01	0.1	%	
$g_{m1,2}$	Transconductance Amplifier $g_m$	$I_{TH1,2} = 1.2\text{V}$ ; Sink/Source $5\mu\text{A}$ ; (Note 4)		2.2		mmho	
$I_Q$	Input DC Supply Current Normal Mode Shutdown	(Note 5)		3		mA	
		$V_{IN} = 15\text{V}$ $V_{RUN1,2} = 0\text{V}$		30	50	$\mu\text{A}$	
UVLO	Undervoltage Lockout on INTV <sub>CC</sub>	V <sub>INTVCC</sub> Ramping Down		3.3		V	
UVLO <sub>HYS</sub>	UVLO Hysteresis			0.55		V	
V <sub>OVL</sub>	Feedback Overvoltage Lockout	Measured at $V_{OSENSE1,2}$ with VID Pins Floating	●	0.64	0.66	0.68	V
$I_{SENSE}$	Sense Pins Total Current	(Each Channel); $V_{SENSE1,2} = 3.3\text{V}$		±1	±2	$\mu\text{A}$	
DF <sub>MAX</sub>	Maximum Duty Cycle	In Dropout		94	95	%	
$I_{TK/SS1,2}$	Soft-Start Charge Current	$V_{TK/SS1,2} = 0\text{V}$		0.9	1.3	1.7	$\mu\text{A}$
$V_{RUN1,2}$	RUN Pin On Threshold	$V_{RUN1}, V_{RUN2}$ Rising	●	1.1	1.22	1.35	V
$V_{RUN1,2HYS}$	RUN Pin On Hysteresis			80		mV	
$I_{RUN1,2HYS}$	RUN Pin Current Hysteresis			4.5		$\mu\text{A}$	
$V_{SENSE(MAX)}$	Maximum Current Sense Threshold (E-Grade)	$V_{ITH1,2} = 3.3\text{V}$ , $I_{LIM} = 0\text{V}$	●	24	30	36	mV
		$V_{ITH1,2} = 3.3\text{V}$ , $I_{LIM} = \text{Float}$	●	44	50	56	mV
		$V_{ITH1,2} = 3.3\text{V}$ , $I_{LIM} = \text{INTV}_{CC}$	●	68	75	82	mV
		In Overvoltage Condition	●	-63	-53	-43	mV
	Maximum Current Sense Threshold (I-Grade)	$V_{ITH1,2} = 3.3\text{V}$ , $I_{LIM} = 0\text{V}$	●	22	30	38	V
		$V_{ITH1,2} = 3.3\text{V}$ , $I_{LIM} = \text{Float}$	●	42	50	58	V
		$V_{ITH1,2} = 3.3\text{V}$ , $I_{LIM} = \text{INTV}_{CC}$	●	66	75	84	V
		In Overvoltage Condition	●	-65	-53	-41	V
TG R <sub>UP</sub>	TG Driver Pull-Up On-Resistance	TG High		2.6		$\Omega$	
TG R <sub>DOWN</sub>	TG Driver Pull-Down On-Resistance	TG Low		1.5		$\Omega$	
BG R <sub>UP</sub>	BG Driver Pull-Up On-Resistance	BG High		3		$\Omega$	

3865f

## ELECTRICAL CHARACTERISTICS

The ● denotes the specifications which apply over the full operating junction temperature range, otherwise specifications are at  $T_J = 25^\circ\text{C}$ .  $V_{IN} = 15\text{V}$ ,  $V_{RUN1,2} = 5\text{V}$  unless otherwise noted.

SYMBOL	PARAMETER	CONDITIONS	MIN	TYP	MAX	UNITS
BG R <sub>DOWN</sub>	BG Driver Pull-Down On-Resistance	BG Low		1.4		Ω
TG <sub>1,2</sub> t <sub>r</sub> TG <sub>1,2</sub> t <sub>f</sub>	TG Transition Time: Rise Time Fall Time	(Note 6) C <sub>LOAD</sub> = 3300pF C <sub>LOAD</sub> = 3300pF		25 25		ns ns
BG <sub>1,2</sub> t <sub>r</sub> BG <sub>1,2</sub> t <sub>f</sub>	BG Transition Time: Rise Time Fall Time	(Note 6) C <sub>LOAD</sub> = 3300pF C <sub>LOAD</sub> = 3300pF		25 25		ns ns
TG/BG t <sub>1D</sub>	Top Gate Off to Bottom Gate On Delay Synchronous Switch-On Delay Time	C <sub>LOAD</sub> = 3300pF Each Driver		30		ns
BG/TG t <sub>2D</sub>	Bottom Gate Off to Top Gate On Delay Top Switch-On Delay Time	C <sub>LOAD</sub> = 3300pF Each Driver		30		ns
t <sub>ON(MIN)</sub>	Minimum On-Time	(Note 7)		90		ns
<b>INTV<sub>CC</sub> Linear Regulator</b>						
V <sub>INTVCC</sub>	Internal V <sub>CC</sub> Voltage	6V < V <sub>IN</sub> < 38V	4.8	5.0	5.2	V
V <sub>LDO INT</sub>	INTV <sub>CC</sub> Load Regulation	I <sub>CC</sub> = 0mA to 20mA		0.5	2	%
V <sub>EXTVCC</sub>	EXTV <sub>CC</sub> Switchover Voltage	EXTV <sub>CC</sub> Ramping Positive ●	4.5	4.7		V
V <sub>LDO EXT</sub>	EXTV <sub>CC</sub> Voltage Drop	I <sub>CC</sub> = 20mA, V <sub>EXTVCC</sub> = 5V		50	100	mV
V <sub>LDOHYS</sub>	EXTV <sub>CC</sub> Hysteresis			200		mV
<b>Oscillator and Phase-Locked Loop</b>						
f <sub>NOM</sub>	Nominal Frequency	R <sub>FREQ</sub> = 162k	450	500	550	kHz
f <sub>LOW</sub>	Lowest Frequency	R <sub>FREQ</sub> = 0Ω	210	250	290	kHz
f <sub>HIGH</sub>	Highest Frequency	R <sub>FREQ</sub> ≥ 325k	650	770	880	kHz
R <sub>MODE/PLLIN</sub>	MODE/PLLIN Input Resistance			250		kΩ
I <sub>FREQ</sub>	Frequency Setting Current		6.5	7.5	8.5	μA
<b>PGOOD OUTPUT</b>						
V <sub>PGL</sub>	PGOOD Voltage Low	I <sub>PGOOD</sub> = 2mA		0.1	0.3	V
I <sub>PGOOD</sub>	PGOOD Leakage Current	V <sub>PGOOD</sub> = 5V			±2	μA
V <sub>PG</sub>	PGOOD Trip Level	V <sub>OSENSE</sub> with Respect to Set Regulated Voltage VID11 = VID12 = VID21 = VID22 = Float V <sub>OSENSE</sub> Ramping Negative V <sub>OSENSE</sub> Ramping Positive	-7 7	-10 10	-12.5 12.5	% %
t <sub>PG</sub>	PGOOD Bad Blanking Time	Measured from VID Transition Edge		100		μs

**Note 1:** Stresses beyond those listed under Absolute Maximum Ratings may cause permanent damage to the device. Exposure to any Absolute Maximum Rating condition for extended periods may affect device reliability and lifetime.

**Note 2:** The LTC3865E/LTC3865E-1 are guaranteed to meet performance specifications over the 0°C to 85°C operating junction temperature range. Specifications over the -40°C to 85°C operating junction temperature range are assured by design, characterization and correlation with statistical process controls. The LTC3865I/LTC3865I-1 are guaranteed to meet performance specifications over the full -40°C to 125°C operating junction temperature range. Note that the maximum ambient temperature is determined by specific operating conditions in conjunction with board layout, the rated package thermal resistance and other environmental factors.

**Note 3:**  $T_J$  is calculated from the ambient temperature  $T_A$  and power dissipation  $P_D$  according to the following formulas:

$$\text{LTC3865UH: } T_J = T_A + (P_D \cdot 34^\circ\text{C/W})$$

$$\text{LTC3865FE: } T_J = T_A + (P_D \cdot 25^\circ\text{C/W})$$

**Note 4:** The LTC3865/LTC3865-1 are tested in a feedback loop that servos  $V_{ITH1,2}$  to a specified voltage and measures the resultant  $V_{OSENSE1,2}$ .

**Note 5:** Dynamic supply current is higher due to the gate charge being delivered at the switching frequency. See Applications Information.

**Note 6:** Rise and fall times are measured using 10% and 90% levels. Delay times are measured using 50% levels.

**Note 7:** The minimum on-time condition is specified for an inductor peak-to-peak ripple current 40% of  $I_{MAX}$  (see Minimum On-Time Considerations in the Applications Information section).

**Note 8:**  $V_{SENSE(MAX)}$  defaults to 50mV for the LTC3865-1.

## TYPICAL PERFORMANCE CHARACTERISTICS

### Efficiency vs Load Current

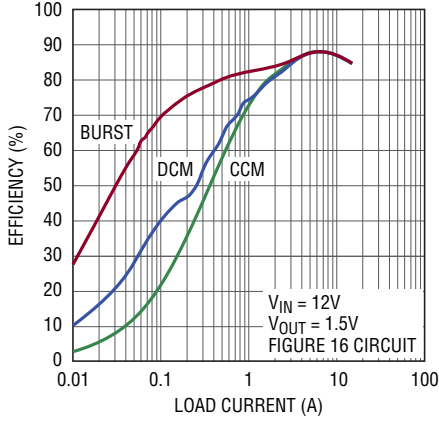

### Efficiency vs Load Current

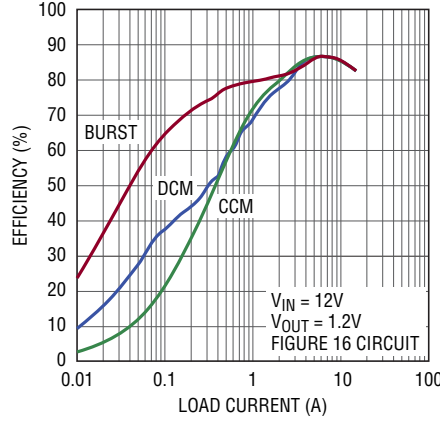

### Efficiency and Power Loss vs Input Voltage

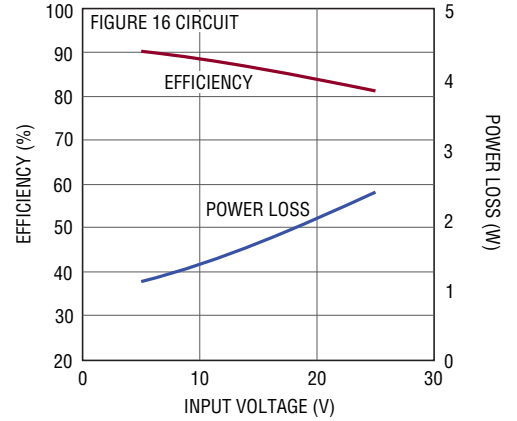

### Load Step (Burst Mode Operation)

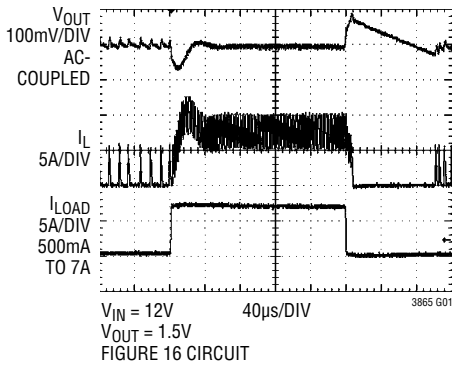

### Load Step (Forced Continuous Mode)

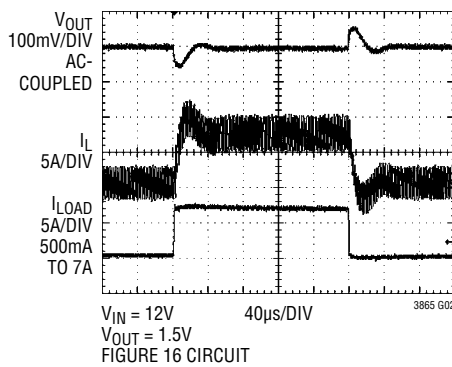

### Load Step (Pulse-Skipping Mode)

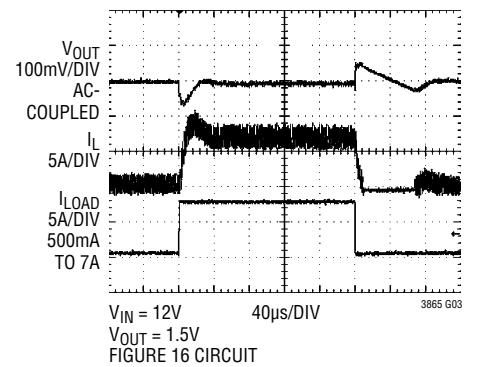

### Inductor Current at Light Load

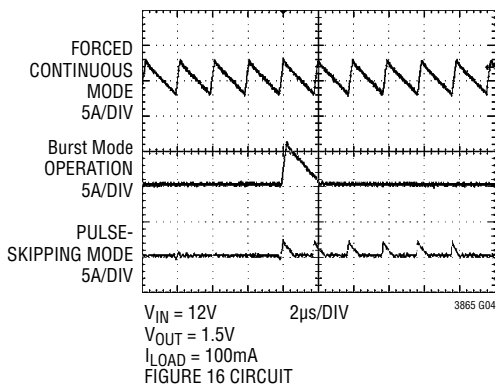

### Prebiased Output at 1V

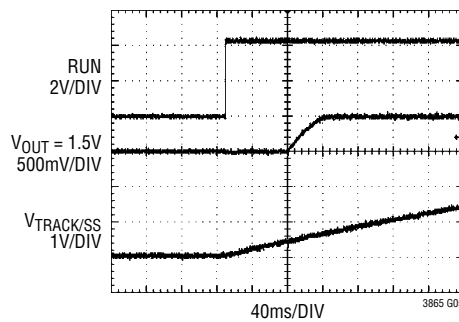

### Coincident Tracking

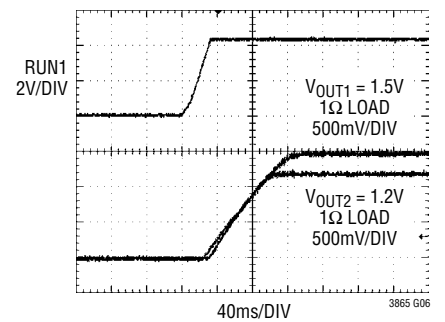

# TYPICAL PERFORMANCE CHARACTERISTICS

**Tracking Up and Down with External Ramp (Forced Continuous Mode)**

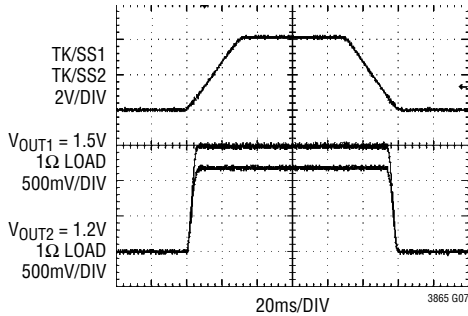

**Quiescent Current vs Input Voltage without EXTV<sub>CC</sub>**

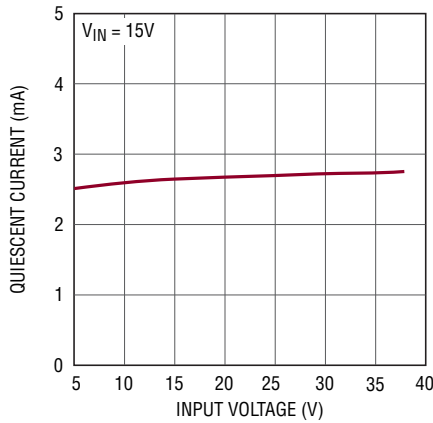

**INTV<sub>CC</sub> Line Regulation**

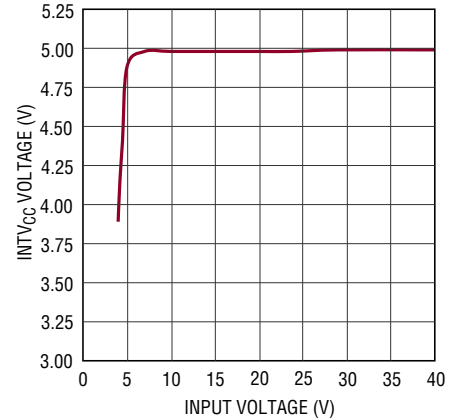

**Current Sense Threshold vs I<sub>TH</sub> Voltage**

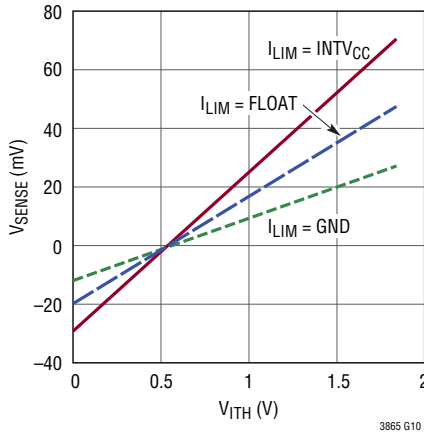

**Maximum Current Sense Threshold vs Common Mode Voltage**

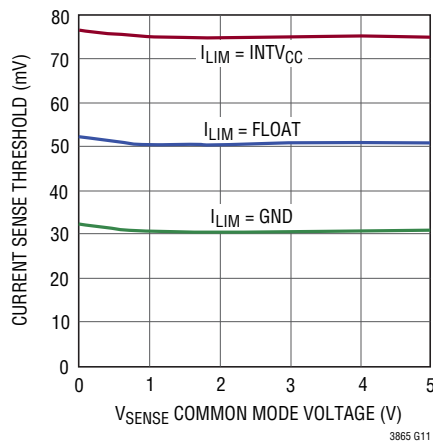

**Maximum Current Sense Threshold vs Duty Cycle**

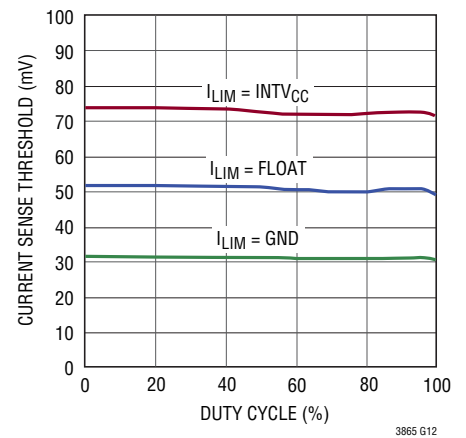

**Maximum Current Sense Voltage vs Feedback Voltage (Current Foldback)**

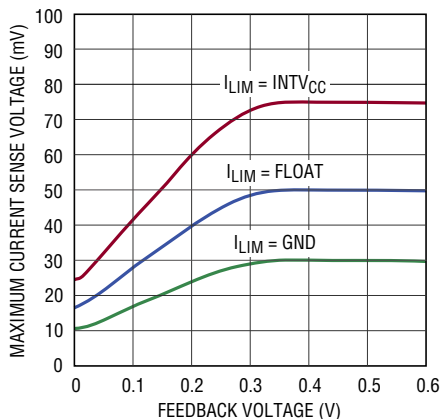

**TK/SS Pull-Up Current vs Temperature**

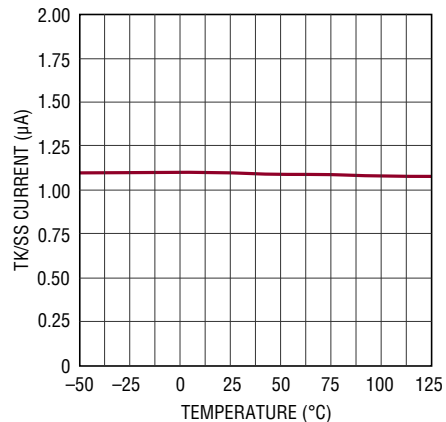

## TYPICAL PERFORMANCE CHARACTERISTICS

**Shutdown (RUN) Threshold vs Temperature**

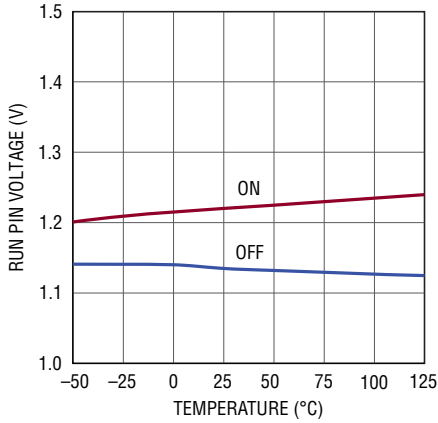

3865 G15

**Regulated Feedback Voltage vs Temperature**

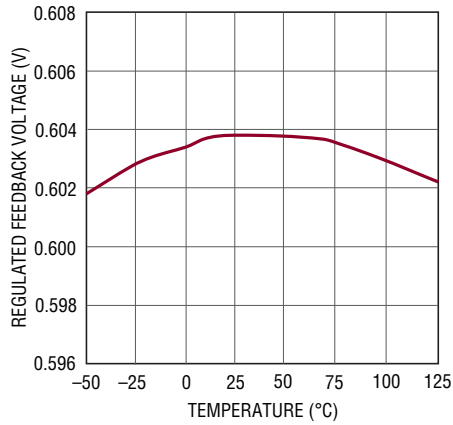

3865 G16

**Oscillator Frequency vs Temperature**

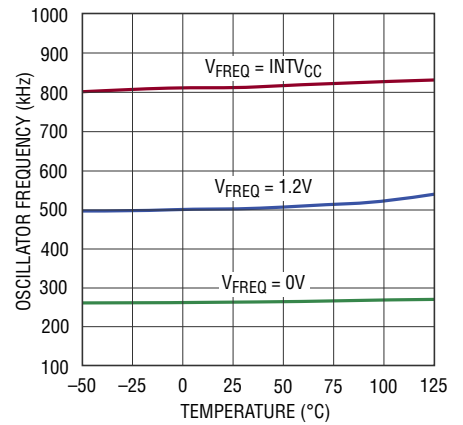

3865 G17

**Undervoltage Lockout Threshold (INTV<sub>CC</sub>) vs Temperature**

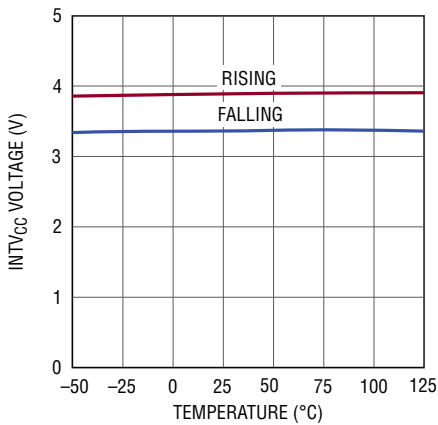

3865 G18

**Oscillator Frequency vs Input Voltage**

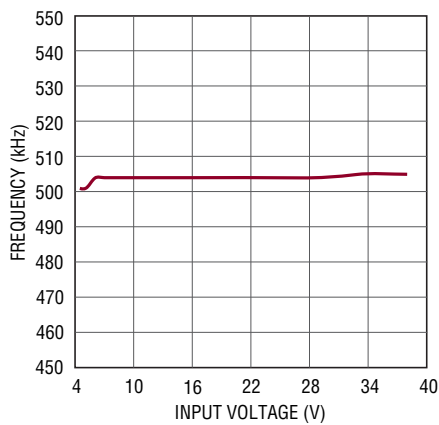

3865 G19

**Shutdown Current vs Input Voltage**

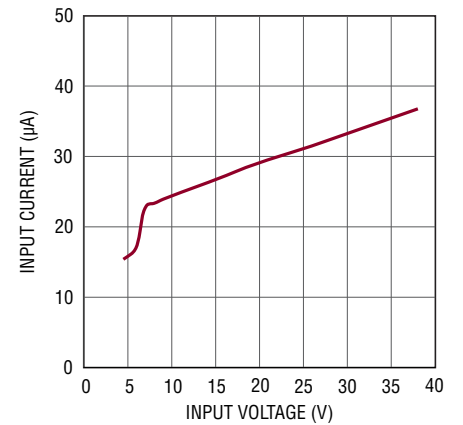

3865 G20

**Shutdown Current vs Temperature**

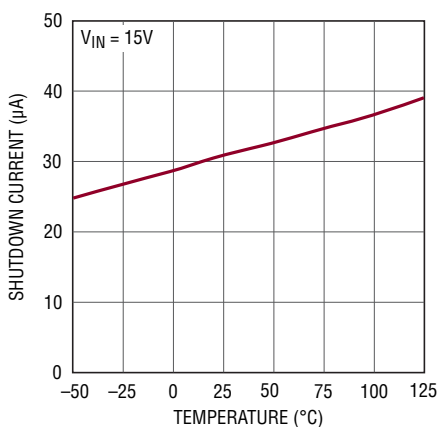

3865 G21

**Quiescent Current vs Temperature without EXT<sub>CC</sub>**

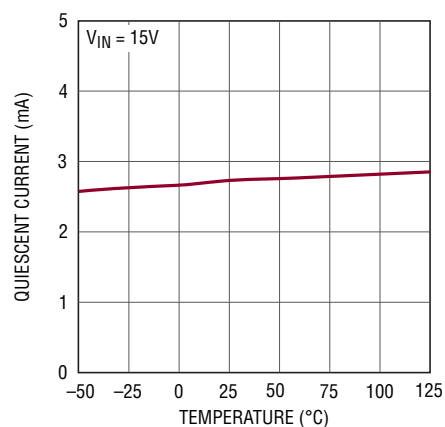

3865 G22



## PIN FUNCTIONS (QFN/TSSOP)

**V<sub>OSENSE1</sub>, V<sub>OSENSE2</sub> (Pins 1, 8/Pins 5, 13):** When the internal programmable resistive divider is used, these pins must be connected to their corresponding outputs. When an external resistive divider is used, these pins are used for error amplifier feedback inputs. They receive the remotely sensed feedback voltages for each channel directly from the outputs or from the external divider across the outputs.

**TK/SS1, TK/SS2 (Pins 2, 7/Pins 6, 12):** Output Voltage Tracking and Soft-Start Inputs. When one channel is configured to be master of the two channels, a capacitor to ground at this pin sets the ramp rate for the master channel's output voltage. When a channel is configured to be the slave of the two channels, the output voltage ramp of the master channel can be reproduced by a resistor divider and applied to this pin of the slave channel. Internal soft-start currents of 1.3 $\mu$ A charge the soft-start capacitors.

**I<sub>TH1</sub>, I<sub>TH2</sub> (Pins 3, 6/Pins 7, 11):** Current Control Thresholds and Error Amplifier Compensation Points. Each associated channels' current comparator tripping threshold increases with its I<sub>TH</sub> control voltage.

**VID11, VID12, VID21, VID22 (Pins 4, 5, 12, 28/ Pins 9, 10, 18, 37):** VID Inputs for Output Voltage Programming. Tie these pins to INTV<sub>CC</sub>, GND or leave them floating to set the output voltages.

**I<sub>LIM</sub> (Pin 13/Pin 19) (LTC3865 Only):** Current Comparator Sense Voltage Range Inputs. This pin can be tied to SGND, FLOAT or INTV<sub>CC</sub> to set the maximum current sense threshold for each comparator. Current comparator sense voltage range of the LTC3865-1 is set to default value of 50mV.

**PGOOD (Pin 14 LTC3865/NA):** Co-Bonded Power Good Indicator Output for LTC3865 in QFN Package. Open-drain logic output that is pulled to ground when either channel output exceeds  $\pm 10\%$  regulation window, after the internal 20 $\mu$ s power bad mask timer expires.

**PGOOD1, PGOOD2 (Pins 14, 13 LTC3865-1/Pins 21, 20):** Separate Power Good Indicator Outputs for LTC3865-1 in QFN package and LTC3865 in FE package. Open-drain logic output that is pulled to ground when the corresponding channel output exceeds  $\pm 10\%$  regulation window, after the internal 20 $\mu$ s power bad mask timer expires.

**PGND (Pin 18/NA):** Power Ground Pin. Connect this pin closely to the sources of the bottom N-channel MOSFETs, the (-) terminal of C<sub>VCC</sub> and the (-) terminal of C<sub>IN</sub>.

**EXTV<sub>CC</sub> (Pin 20/Pin 28):** External Power Input to an Internal Switch Connected to INTV<sub>CC</sub>. This switch closes and supplies the IC power, bypassing the internal low dropout regulator, whenever EXTV<sub>CC</sub> is higher than 4.7V. Do not exceed 6V on this pin.

**INTV<sub>CC</sub> (Pin 21/Pin 29):** Internal 5V Regulator Output. The control circuits are powered from this voltage. Decouple this pin to PGND with a minimum of 4.7 $\mu$ F low ESR tantalum or ceramic capacitor.

**V<sub>IN</sub> (Pin 22/Pin 30):** Main Input Supply. Decouple this pin to PGND with a capacitor (0.1 $\mu$ F to 1 $\mu$ F).

**BG1, BG2 (Pins 23, 19/Pin 31, 27):** Bottom Gate Driver Outputs. These pins drive the gates of the bottom N-channel MOSFETs between PGND and INTV<sub>CC</sub>.

**BOOST1, BOOST2 (Pins 24, 17/Pins 33, 25):** Boosted Floating Driver Supplies. The (+) terminal of the bootstrap capacitors connect to these pins. These pins swing from a diode voltage drop below INTV<sub>CC</sub> up to V<sub>IN</sub> + INTV<sub>CC</sub>.

**TG1, TG2 (Pins 25, 16/Pins 34, 23):** Top Gate Driver Outputs. These are the outputs of floating drivers with a voltage swing equal to INTV<sub>CC</sub> superimposed on the switch nodes voltages.

**SW1, SW2 (Pins 26, 15/Pins 35, 22):** Switch Node Connections to Inductors. Voltage swing at these pins is from a Schottky diode (external) voltage drop below ground to V<sub>IN</sub>.

## PIN FUNCTIONS (QFN/TSSOP)

**MODE/PLLIN (Pin 27/Pin 36):** Force Continuous Mode, Burst Mode or Pulse-Skip Mode Selection Pin and External Synchronization Input to Phase Detector Pin. Connect this pin to SGND to force both channels in continuous mode of operation. Connect to INTV<sub>CC</sub> to enable pulse-skip mode of operation. Leaving the pin floating will enable Burst Mode operation. A clock on the pin will force the controller into continuous mode of operation and synchronize the internal oscillator with the clock on this pin.

**FREQ (Pin 29/Pin 38):** This pin sets the frequency of the internal oscillator. A constant current of 7.5 $\mu$ A is flowing out of this pin and a resistor connected to this pin sets its DC voltage, which in turn, sets the frequency of the internal oscillator.

**RUN1, RUN2 (Pins 30, 11/Pins 1, 17):** Run Control Inputs. A voltage above 1.2V on either pin turns on the IC. However, forcing either of these pins below 1.2V causes the IC to shut down the circuitry required for that particular channel. There are 1 $\mu$ A pull-up currents for these pins. Once the RUN pin rises above 1.2V, an additional 4.5 $\mu$ A pull-up current is added to the pin.

**SENSE1<sup>+</sup>, SENSE2<sup>+</sup> (Pins 31, 10/Pins 2, 16):** Current Sense Comparator Inputs. The (+) inputs to the current comparators are normally connected to DCR sensing networks or current sensing resistors.

**SENSE1<sup>-</sup>, SENSE2<sup>-</sup> (Pins 32, 9/Pin 3, 15):** Current Sense Comparator Inputs. The (-) inputs to the current comparators are connected to the outputs.

**SGND (Pin 33/Pin 8):** Signal Ground. All small-signal components and compensation components should connect to this ground, which in turn connects to PGND at one point. Pin 33 is the Exposed Pad and available for QFN package.

**SGND (Exposed Pad Pin 33/Exposed Pad Pin 39):** Signal Ground. Must be soldered to PCB, providing a local ground for the control components of the IC, and be tied to the PGND pin under the IC.

**PGND1, PGND2 (NA/Pins 32, 26):** Power Ground Pin. Connect this pin closely to the sources of the bottom N-channel MOSFETs, the (-) terminal of C<sub>VCC</sub> and the (-) terminal of C<sub>IN</sub>.

# FUNCTIONAL DIAGRAM

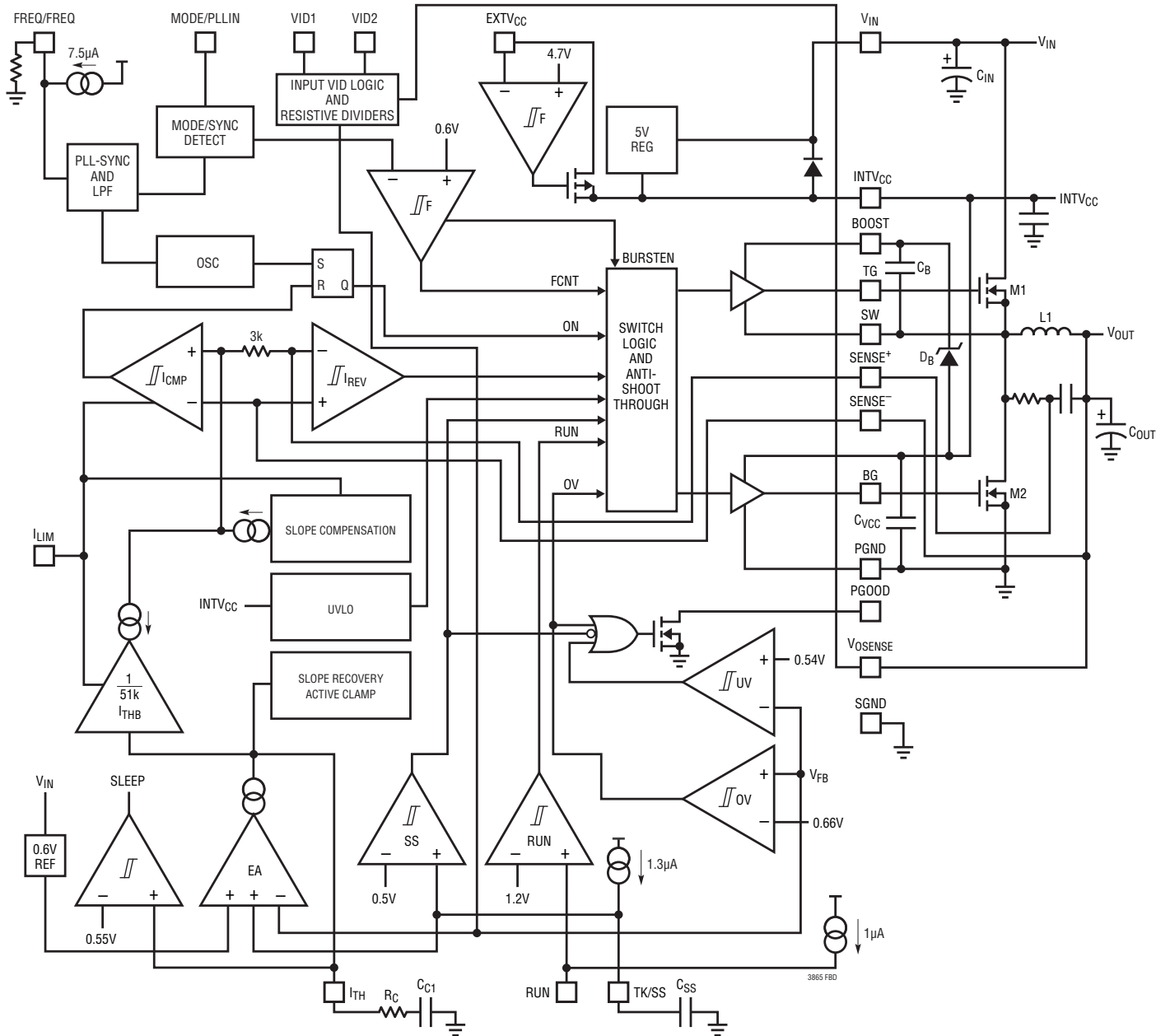

## OPERATION

### Main Control Loop

The LTC3865/LTC3865-1 are constant-frequency, current mode step-down controllers with two channels operating 180 degrees out-of-phase. During normal operation, each top MOSFET is turned on when the clock for that channel sets the RS latch, and turned off when the main current comparator,  $I_{CMP}$ , resets the RS latch. The peak inductor current at which  $I_{CMP}$  resets the RS latch is controlled by the voltage on the  $I_{TH}$  pin, which is the output of each error amplifier, EA (refer to the Functional Diagram).  $V_{FB}$  is the voltage feedback signal, which is compared to the internal reference voltage by the EA. When the load current increases, it causes a slight decrease in feedback voltage relative to the 0.6V reference, which in turn causes the  $I_{TH}$  voltage to increase until the average inductor current matches the new load current. After the top MOSFET has turned off, the bottom MOSFET is turned on until either the inductor current starts to reverse, as indicated by the reverse current comparator  $I_{REV}$ , or the beginning of the next cycle.

### INTV<sub>CC</sub>/EXTV<sub>CC</sub> Power

Power for the top and bottom MOSFET drivers and most other internal circuitry is derived from the INTV<sub>CC</sub> pin. When the EXTV<sub>CC</sub> pin is left open or tied to a voltage less than 4.7V, an internal 5V linear regulator supplies INTV<sub>CC</sub> power from  $V_{IN}$ . If EXTV<sub>CC</sub> is taken above 4.7V, the 5V regulator is turned off and an internal switch is turned on connecting EXTV<sub>CC</sub>. Using the EXTV<sub>CC</sub> pin allows the INTV<sub>CC</sub> power to be derived from a high efficiency external source such as one of the LTC3865/LTC3865-1 switching regulator outputs.

Each top MOSFET driver is biased from the floating bootstrap capacitor,  $C_B$ , which normally recharges during each off cycle through an external diode when the top MOSFET turns off. If the input voltage  $V_{IN}$  decreases to a voltage close to  $V_{OUT}$ , the loop may enter dropout and attempt to turn on the top MOSFET continuously. The dropout detector detects this and forces the top MOSFET off for about one-twelfth of the clock period every third cycle to allow  $C_B$  to recharge. However, it is recommended that a load be present during the drop-out transition to ensure  $C_B$  is recharged.

### Shutdown and Start-Up (RUN1, RUN2 and TK/SS1, TK/SS2 Pins)

The two channels of the LTC3865/LTC3865-1 can be independently shut down using the RUN1 and RUN2 pins. Pulling either of these pins below 1.2V shuts down the main control loop for that controller. Pulling both pins low disables both controllers and most internal circuits, including the INTV<sub>CC</sub> regulator. Releasing either RUN pin allows an internal 1 $\mu$ A current to pull up the pin and enable that controller. Alternatively, the RUN pin may be externally pulled up or driven directly by logic. Be careful not to exceed the absolute maximum rating of 6V on this pin.

The start-up of each controller's output voltage  $V_{OUT}$  is controlled by the voltage on the TK/SS1 and TK/SS2 pins. When the voltage on the TK/SS pin is less than the 0.6V internal reference, the LTC3865 regulates the  $V_{FB}$  voltage to the TK/SS pin voltage instead of the 0.6V reference. This allows the TK/SS pin to be used to program a soft-start by connecting an external capacitor from the TK/SS pin to SGND. An internal 1.3 $\mu$ A pull-up current charges this capacitor, creating a voltage ramp on the TK/SS pin. As the TK/SS voltage rises linearly from 0V to 0.6V (and beyond), the output voltage,  $V_{OUT}$ , rises smoothly from zero to its final value. Alternatively the TK/SS pin can be used to cause the start-up of  $V_{OUT}$  to "track" that of another supply. Typically, this requires connecting to the TK/SS pin an external resistor divider from the other supply to ground (see the Applications Information section). When the corresponding RUN pin is pulled low to disable a controller, or when INTV<sub>CC</sub> drops below its undervoltage lockout threshold of 3.3V, the TK/SS pin is pulled low by an internal MOSFET. When in undervoltage lockout, both controllers are disabled and the external MOSFETs are held off.

### Light Load Current Operation (Burst Mode Operation, Pulse-Skipping or Continuous Conduction)

The LTC3865/LTC3865-1 can be enabled to enter high efficiency Burst Mode operation, constant-frequency pulse-skipping mode, or forced continuous conduction mode. To select forced continuous operation, tie the MODE/PLLIN

## OPERATION

pin to a DC voltage below 0.6V (e.g., SGND). To select pulse-skipping mode of operation, tie the MODE/PLLIN pin to INTV<sub>CC</sub>. To select Burst Mode operation, float the MODE/PLLIN pin. When a controller is enabled for Burst Mode operation, the peak current in the inductor is set to approximately one-third of the maximum sense voltage even though the voltage on the I<sub>TH</sub> pin indicates a lower value. If the average inductor current is higher than the load current, the error amplifier EA will decrease the voltage on the I<sub>TH</sub> pin. When the I<sub>TH</sub> voltage drops below 0.5V, the internal sleep signal goes high (enabling “sleep” mode) and both external MOSFETs are turned off.

In sleep mode, the load current is supplied by the output capacitor. As the output voltage decreases, the EA’s output begins to rise. When the output voltage drops enough, the sleep signal goes low, and the controller resumes normal operation by turning on the top external MOSFET on the next cycle of the internal oscillator. When a controller is enabled for Burst Mode operation, the inductor current is not allowed to reverse. The reverse current comparator (I<sub>REV</sub>) turns off the bottom external MOSFET just before the inductor current reaches zero, preventing it from reversing and going negative. Thus, the controller operates in discontinuous operation. In forced continuous operation, the inductor current is allowed to reverse at light loads or under large transient conditions. The peak inductor current is determined by the voltage on the I<sub>TH</sub> pin, just as in normal operation. In this mode, the efficiency at light loads is lower than in Burst Mode operation. However, continuous mode has the advantages of lower output ripple and less interference with audio circuitry.

When the MODE/PLLIN pin is connected to INTV<sub>CC</sub>, the LTC3865 operates in PWM pulse-skipping mode at light loads. At very light loads, the current comparator, I<sub>CMP</sub>, may remain tripped for several cycles and force the external top MOSFET to stay off for the same number of cycles (i.e., skipping pulses). The inductor current is not allowed to reverse (discontinuous operation). This mode, like forced continuous operation, exhibits low output ripple as well as low audio noise and reduced RF interference as compared to Burst Mode operation. It provides higher low current efficiency than forced continuous mode, but not nearly as high as Burst Mode operation.

### Frequency Selection and Phase-Locked Loop (FREQ and MODE/PLLIN Pins)

The selection of switching frequency is a trade-off between efficiency and component size. Low frequency operation increases efficiency by reducing MOSFET switching losses, but requires larger inductance and/or capacitance to maintain low output ripple voltage. The switching frequency of the LTC3865’s controllers can be selected using the FREQ pin. If the MODE/PLLIN pin is not being driven by an external clock source, the FREQ pin can be used to program the controller’s operating frequency from 250kHz to 770kHz.

There is a precision 7.5μA current flow out of FREQ pin that user can program the controller’s switching frequency with a single resistor to SGND. A curve is provided later in the application section showing the relationship between the voltage on the FREQ pin and switching frequency.

A phase-locked loop (PLL) is integrated on the LTC3865 to synchronize the internal oscillator to an external clock source that is connected to the MODE/PLLIN pin. The controller is operating in forced continuous mode when it is synchronized.

The PLL loop filter network is integrated inside the LTC3865/LTC3865-1. The phase-locked loop is capable of locking any frequency within the range of 250kHz to 770kHz. The frequency setting resistor should always be present to set the controller’s initial switching frequency before locking to the external clock.

### Power Good (PGOOD Pins)

On the LTC3865 (UH32 package), the PGOOD pin is bonded to the open drains of two individual internal N-channel MOSFETs. When either V<sub>OSENSE</sub> voltage is not within ±10% of the programmed voltage, the PGOOD pin is pulled low. The PGOOD pin is also pulled low when either RUN pin is below 1.2V or when the LTC3865 is in the soft-start or tracking phase. The PGOOD pin will flag power good immediately when both V<sub>OSENSE</sub> are within the ±10% of the programmed output voltage window. However, there is an internal 20μs power bad mask when either V<sub>OSENSE</sub> goes out the ±10% window. The internal



## OPERATION

power bad mask is 100 $\mu$ s when there are any VID transitions. On the LTC3865-1 (UH32 package) or the LTC3865 (FE38 package), each channel has its own PGOOD pin. Therefore, the PGOOD pins now only respond to their own channels. The PGOOD pins are allowed to be pulled up by external resistors to sources of up to 6V.

### Output Overvoltage Protection

An overvoltage comparator, OV, guards against transient overshoots (>10%) as well as other more serious conditions that may overvoltage the output. In such cases, the top MOSFET is turned off and the bottom MOSFET is turned on until the reverse current limit for the overvoltage condition is reached. The bottom MOSFET will be turned on again at the next clock and be turned off when the reverse current limit is reached again. This process repeats until the overvoltage condition is cleared.

### Output Voltage Programming

The output voltages of both channels of the LTC3865/LTC3865-1 can be programmed to a preset value. There are two VID pins for each channel and by connecting these pins to INTV<sub>CC</sub>, GND, or by floating them, the output voltages can be set to the values in Table 1.

**Table 1. Programming of Output Voltage**

VID11/VID21	VID12/VID22	V <sub>OUT1</sub> /V <sub>OUT2</sub> (V)
INTV <sub>CC</sub>	INTV <sub>CC</sub>	5.0
INTV <sub>CC</sub>	Float	3.3
INTV <sub>CC</sub>	GND	2.5
Float	INTV <sub>CC</sub>	1.8
Float	Float	0.6 or External Divider
Float	GND	1.5
GND	INTV <sub>CC</sub>	1.2
GND	Float	1.0
GND	GND	1.1

## APPLICATIONS INFORMATION

The Typical Application on the first page is a basic LTC3865 application circuit. The LTC3865 can be configured to use either DCR (inductor resistance) sensing or low value resistor sensing. The choice between the two current sensing schemes is largely a design trade-off between cost, power consumption and accuracy. DCR sensing is becoming popular because it saves expensive current sensing resistors and is more power efficient, especially in high current applications. However, current sensing resistors provide the most accurate current limits for the controller. Other external component selection is driven by the load requirement, and begins with the selection of R<sub>SENSE</sub> (if R<sub>SENSE</sub> is used) and inductor value. Next, the power MOSFETs are selected. Finally, input and output capacitors are selected.

### Current Limit Programming

The I<sub>LIM</sub> pin is a tri-level logic input which sets the maximum current limit of the controller. When I<sub>LIM</sub> is either grounded, floated or tied to INTV<sub>CC</sub>, the typical value for the maximum current sense threshold will be 30mV, 50mV or 75mV, respectively.

Which setting should be used? For the best current limit accuracy, use the 75mV setting. The 30mV setting will allow for the use of very low DCR inductors or sense resistors, but at the expense of current limit accuracy. The 50mV setting is a good balance between the two. For single output dual phase applications, use the 50mV or 75mV setting for optimal current sharing.

### SENSE<sup>+</sup> and SENSE<sup>-</sup> Pins

The SENSE<sup>+</sup> and SENSE<sup>-</sup> pins are the inputs to the current comparators. The common mode input voltage range of the current comparators is 0V to 5V. Both SENSE pins are high impedance inputs with small base currents of less than 1 $\mu$ A. When the SENSE pins ramp up from 0V to 1.4V, the small base currents flow out of the SENSE pins. When the SENSE pins ramp down from 5V to 1.1V, the small base currents flow into the SENSE pins. The high impedance inputs to the current comparators allow accurate DCR sensing. However, care must be taken not to float these pins during normal operation.

## APPLICATIONS INFORMATION

Filter components mutual to the sense lines should be placed close to the LTC3865/LTC3865-1, and the sense lines should run close together to a Kelvin connection underneath the current sense element (shown in Figure 1). Sensing current elsewhere can effectively add parasitic inductance and capacitance to the current sense element, degrading the information at the sense terminals and making the programmed current limit unpredictable. If DCR sensing is used (Figure 2b), sense resistor R1 should be placed close to the switching node, to prevent noise from coupling into sensitive small-signal nodes. The capacitor C1 should be placed close to the IC pins.

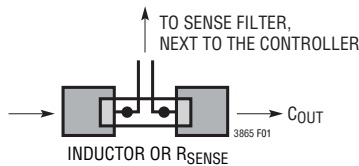

Figure 1. Sense Lines Placement with Inductor or Sense Resistor

### Low Value Resistors Current Sensing

A typical sensing circuit using a discrete resistor is shown in Figure 2a.  $R_{SENSE}$  is chosen based on the required output current.

The current comparator has a maximum threshold  $V_{SENSE(MAX)}$  determined by the  $I_{LIM}$  setting. The input common mode range of the current comparator is 0V to 5V. The current comparator threshold sets the peak of the inductor current, yielding a maximum average output current  $I_{MAX}$  equal to the peak value less half the peak-to-peak ripple current,  $\Delta I_L$ . To calculate the sense resistor value, use the equation:

$$R_{SENSE} = \frac{V_{SENSE(MAX)}}{I_{(MAX)} + \frac{\Delta I_L}{2}}$$

Because of possible PCB noise in the current sensing loop, the AC current sensing ripple of  $\Delta V_{SENSE} = \Delta I_L \cdot R_{SENSE}$  also needs to be checked in the design to get a good signal-to-noise ratio. In general, for a reasonably good PCB layout, a 15mV  $\Delta V_{SENSE}$  voltage is recommended as a conservative number to start with, either for  $R_{SENSE}$  or DCR sensing applications.

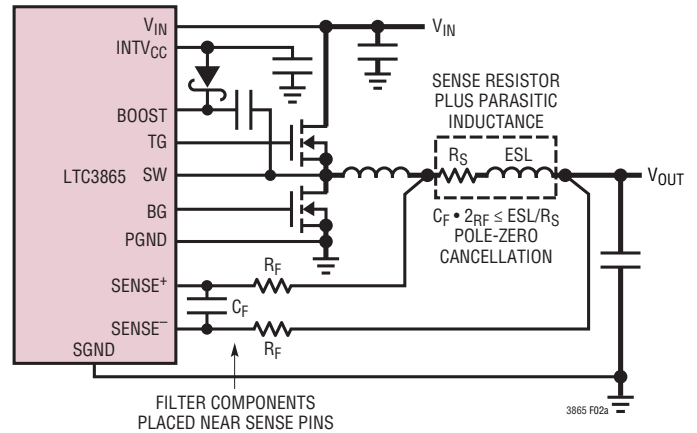

(2a) Using a Resistor to Sense Current

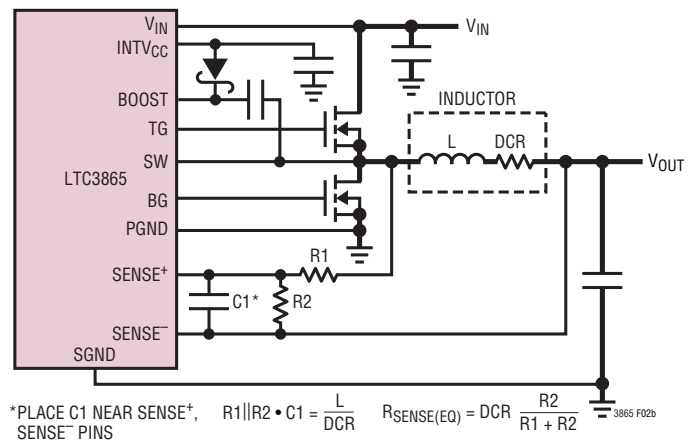

(2b) Using the Inductor DCR to Sense Current

Figure 2. Two Different Methods of Sensing Current

For previous generation current mode controllers, the maximum sense voltage was high enough (e.g., 75mV for the LTC1628/LTC3728 family) that the voltage drop across the parasitic inductance of the sense resistor represented a relatively small error. For today's highest current density solutions, however, the value of the sense resistor can be less than 1mΩ and the peak sense voltage can be as low as 20mV. In addition, inductor ripple currents greater than 50% with operation up to 1MHz are becoming more common. Under these conditions the voltage drop across the sense resistor's parasitic inductance is no longer negligible. A typical sensing circuit using a discrete resistor is shown in Figure 2a. In previous generations of controllers, a small RC filter placed near the IC was commonly used to reduce the effects of capacitive and inductive noise coupled in

## APPLICATIONS INFORMATION

the sense traces on the PCB. A typical filter consists of two series 10Ω resistors connected to a parallel 1000pF capacitor, resulting in a time constant of 20ns.

This same RC filter, with minor modifications, can be used to extract the resistive component of the current sense signal in the presence of parasitic inductance. For example, Figure 3 illustrates the voltage waveform across a 2mΩ sense resistor with a 2010 footprint for the 1.2V/15A converter operating at 100% load. The waveform is the superposition of a purely resistive component and a purely inductive component. It was measured using two scope probes and waveform math to obtain a differential measurement. Based on additional measurements of the inductor ripple current and the on-time and off-time of the top switch, the value of the parasitic inductance was determined to be 0.5nH using the equation:

$$ESL = \frac{V_{ESL(STEP)} \cdot t_{ON} \cdot t_{OFF}}{\Delta I_L \cdot (t_{ON} + t_{OFF})}$$

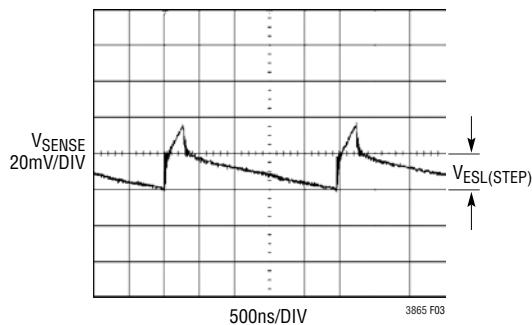

**Figure 3. Voltage Waveform Measured Directly Across the Sense Resistor**

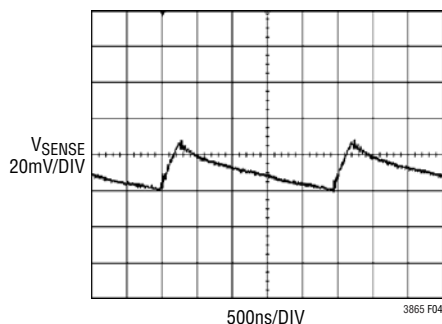

**Figure 4. Voltage Waveform Measured After the Sense Resistor Filter.  $C_F = 1000\text{pF}$ ,  $R_F = 100\Omega$**

If the RC time constant is chosen to be close to the parasitic inductance divided by the sense resistor ( $L/R$ ), the resulting waveform looks resistive again, as shown in Figure 4. For applications using low maximum sense voltages, check the sense resistor manufacturer’s data sheet for information about parasitic inductance. In the absence of data, measure the voltage drop directly across the sense resistor to extract the magnitude of the ESL step and use the equation above to determine the ESL. However, do not over filter. Keep the RC time constant less than or equal to the inductor time constant to maintain a high enough ripple voltage on  $V_{RSENSE}$ .

The above generally applies to high density/high current applications where  $I_{(MAX)} > 10\text{A}$  and low values of inductors are used. For applications where  $I_{(MAX)} < 10\text{A}$ , set  $R_F$  to 10Ω and  $C_F$  to 1000pF. This will provide a good starting point.

The filter components need to be placed close to the IC. The positive and negative sense traces need to be routed as a differential pair and Kelvin connected to the sense resistor.

### Inductor DCR Sensing

For applications requiring the highest possible efficiency at high load currents, the LTC3865/LTC3865-1 are capable of sensing the voltage drop across the inductor DCR, as shown in Figure 2b. The DCR of the inductor represents the small amount of DC winding resistance of the copper, which can be less than 1mΩ for today’s low value, high current inductors. In a high current application requiring such an inductor, conduction loss through a sense resistor would cost several points of efficiency compared to DCR sensing.

If the external  $R1||R2 \cdot C1$  time constant is chosen to be exactly equal to the  $L/DCR$  time constant, the voltage drop across the external capacitor is equal to the drop across the inductor DCR multiplied by  $R2/(R1 + R2)$ .  $R2$  scales the voltage across the sense terminals for applications where the DCR is greater than the target sense resistor value. To properly dimension the external filter components, the DCR of the inductor must be known. It can be measured using a good RLC meter, but the DCR tolerance is not



## APPLICATIONS INFORMATION

always the same and varies with temperature; consult the manufacturers' data sheets for detailed information.

Using the inductor ripple current value from the Inductor Value Calculation section, the target sense resistor value is:

$$R_{\text{SENSE(EQUIV)}} = \frac{V_{\text{SENSE(MAX)}}}{I_{\text{(MAX)}} + \frac{\Delta I_L}{2}}$$

To ensure that the application will deliver full load current over the full operating temperature range, choose the minimum value for the Maximum Current Sense Threshold ( $V_{\text{SENSE(MAX)}}$ ) in the Electrical Characteristics table (24mV, 44mV or 68mV, depending on the state of the  $I_{\text{LIM}}$  pin).

Next, determine the DCR of the inductor. Where provided, use the manufacturer's maximum value, usually given at 20°C. Increase this value to account for the temperature coefficient of resistance, which is approximately 0.4%/°C. A conservative value for  $T_{\text{L(MAX)}}$  is 100°C.

To scale the maximum inductor DCR to the desired sense resistor value, use the divider ratio:

$$R_D = \frac{R_{\text{SENSE(EQUIV)}}}{\text{DCR}_{\text{(MAX)}} \text{ at } T_{\text{L(MAX)}}}$$

$C_1$  is usually selected to be in the range of 0.047μF to 0.47μF. This forces  $R_1||R_2$  to around 2kΩ, reducing error that might have been caused by the SENSE pins' ±1μA current.

The equivalent resistance  $R_1||R_2$  is scaled to the room temperature inductance and maximum DCR:

$$R_1||R_2 = \frac{L}{(\text{DCR at } 20^\circ\text{C}) \cdot C_1}$$

The sense resistor values are:

$$R_1 = \frac{R_1||R_2}{R_D}; \quad R_2 = \frac{R_1 \cdot R_D}{1 - R_D}$$

The maximum power loss in  $R_1$  is related to duty cycle, and will occur in continuous mode at the maximum input voltage:

$$P_{\text{LOSS } R_1} = \frac{(V_{\text{IN(MAX)}} - V_{\text{OUT}}) \cdot V_{\text{OUT}}}{R_1}$$

Ensure that  $R_1$  has a power rating higher than this value. If high efficiency is necessary at light loads, consider this power loss when deciding whether to use DCR sensing or sense resistors. Light load power loss can be modestly higher with a DCR network than with a sense resistor, due to the extra switching losses incurred through  $R_1$ . However, DCR sensing eliminates a sense resistor, reduces conduction losses and provides higher efficiency at heavy loads. Peak efficiency is about the same with either method.

To maintain a good signal to noise ratio for the current sense signal, use a minimum  $\Delta V_{\text{SENSE}}$  of 10mV to 15mV. For a DCR sensing application, the actual ripple voltage will be determined by the equation:

$$\Delta V_{\text{SENSE}} = \frac{V_{\text{IN}} - V_{\text{OUT}}}{R_1 \cdot C_1} \frac{V_{\text{OUT}}}{V_{\text{IN}} \cdot f_{\text{OSC}}}$$

### Slope Compensation and Inductor Peak Current

Slope compensation provides stability in constant-frequency architectures by preventing subharmonic oscillations at high duty cycles. It is accomplished internally by adding a compensating ramp to the inductor current signal at duty cycles in excess of 40%. Normally, this results in a reduction of maximum inductor peak current for duty cycles >40%. However, the LTC3865/LTC3865-1 use a patented scheme that counteracts this compensating ramp, which allows the maximum inductor peak current to remain unaffected throughout all duty cycles.

### Inductor Value Calculation

Given the desired input and output voltages, the inductor value and operating frequency  $f_{\text{OSC}}$  directly determine the inductor's peak-to-peak ripple current:

$$I_{\text{RIPPLE}} = \frac{V_{\text{OUT}}}{V_{\text{IN}}} \left( \frac{V_{\text{IN}} - V_{\text{OUT}}}{f_{\text{OSC}} \cdot L} \right)$$

## APPLICATIONS INFORMATION

Lower ripple current reduces core losses in the inductor, ESR losses in the output capacitors, and output voltage ripple. Thus, highest efficiency operation is obtained at low frequency with a small ripple current. Achieving this, however, requires a large inductor.

A reasonable starting point is to choose a ripple current that is about 40% of  $I_{OUT(MAX)}$ . Note that the largest ripple current occurs at the highest input voltage. To guarantee that ripple current does not exceed a specified maximum, the inductor should be chosen according to:

$$L \geq \frac{V_{IN} - V_{OUT}}{f_{OSC} \cdot I_{RIPPLE}} \cdot \frac{V_{OUT}}{V_{IN}}$$

### Inductor Core Selection

Once the inductance value is determined, the type of inductor must be selected. Core loss is independent of core size for a fixed inductor value, but it is very dependent on inductance selected. As inductance increases, core losses go down. Unfortunately, increased inductance requires more turns of wire and therefore copper losses will increase.

Ferrite designs have very low core loss and are preferred at high switching frequencies, so design goals can concentrate on copper loss and preventing saturation. Ferrite core material saturates “hard,” which means that inductance collapses abruptly when the peak design current is exceeded. This results in an abrupt increase in inductor ripple current and consequent output voltage ripple. Do not allow the core to saturate!

### Power MOSFET and Schottky Diode (Optional) Selection

Two external power MOSFETs must be selected for each controller in the LTC3865/LTC3865-1: one N-channel MOSFET for the top (main) switch, and one N-channel MOSFET for the bottom (synchronous) switch.

The peak-to-peak drive levels are set by the  $INTV_{CC}$  voltage. This voltage is typically 5V during start-up (see  $EXTV_{CC}$  Pin Connection). Consequently, logic-level threshold MOSFETs must be used in most applications. The only exception is if low input voltage is expected

( $V_{IN} < 5V$ ); then, sub-logic level threshold MOSFETs ( $V_{GS(TH)} < 3V$ ) should be used. Pay close attention to the  $BV_{DSS}$  specification for the MOSFETs as well; most of the logic-level MOSFETs are limited to 30V or less.

Selection criteria for the power MOSFETs include the on-resistance,  $R_{DS(ON)}$ , Miller capacitance,  $C_{MILLER}$ , input voltage and maximum output current. Miller capacitance,  $C_{MILLER}$ , can be approximated from the gate charge curve usually provided on the MOSFET manufacturers’ data sheet.  $C_{MILLER}$  is equal to the increase in gate charge along the horizontal axis while the curve is approximately flat divided by the specified change in  $V_{DS}$ . This result is then multiplied by the ratio of the application applied  $V_{DS}$  to the gate charge curve specified  $V_{DS}$ . When the IC is operating in continuous mode the duty cycles for the top and bottom MOSFETs are given by:

$$\text{Main Switch Duty Cycle} = \frac{V_{OUT}}{V_{IN}}$$

$$\text{Synchronous Switch Duty Cycle} = \frac{V_{IN} - V_{OUT}}{V_{IN}}$$

The MOSFET power dissipations at maximum output current are given by:

$$P_{MAIN} = \frac{V_{OUT}}{V_{IN}} (I_{MAX})^2 (1 + \delta) R_{DS(ON)} + (V_{IN})^2 \left( \frac{I_{MAX}}{2} \right) (R_{DR}) (C_{MILLER}) \cdot \left[ \frac{1}{V_{INTVCC} - V_{TH(MIN)}} + \frac{1}{V_{TH(MIN)}} \right] \cdot f_{OSC}$$

$$P_{SYNC} = \frac{V_{IN} - V_{OUT}}{V_{IN}} (I_{MAX})^2 (1 + \delta) R_{DS(ON)}$$

where  $\delta$  is the temperature dependency of  $R_{DS(ON)}$  and  $R_{DR}$  (approximately  $2\Omega$ ) is the effective driver resistance at the MOSFET’s Miller threshold voltage.  $V_{TH(MIN)}$  is the typical MOSFET minimum threshold voltage.

Both MOSFETs have  $I^2R$  losses while the topside N-channel equation includes an additional term for transition losses,

## APPLICATIONS INFORMATION

which are highest at high input voltages. For  $V_{IN} < 20V$  the high current efficiency generally improves with larger MOSFETs, while for  $V_{IN} > 20V$  the transition losses rapidly increase to the point that the use of a higher  $R_{DS(ON)}$  device with lower  $C_{MILLER}$  actually provides higher efficiency. The synchronous MOSFET losses are greatest at high input voltage when the top switch duty factor is low or during a short-circuit when the synchronous switch is on close to 100% of the period.

The term  $(1 + \delta)$  is generally given for a MOSFET in the form of a normalized  $R_{DS(ON)}$  vs Temperature curve, but  $\delta = 0.005/^{\circ}C$  can be used as an approximation for low voltage MOSFETs.

The optional Schottky diodes conduct during the dead time between the conduction of the two power MOSFETs. These prevent the body diodes of the bottom MOSFETs from turning on, storing charge during the dead time and requiring a reverse recovery period that could cost as much as 3% in efficiency at high  $V_{IN}$ . A 1A to 3A Schottky is generally a good compromise for both regions of operation due to the relatively small average current. Larger diodes result in additional transition losses due to their larger junction capacitance.

### Soft-Start and Tracking

The LTC3865/LTC3865-1 have the ability to either soft-start by themselves with a capacitor or track the output of another channel or external supply. When one particular channel is configured to soft-start by itself, a capacitor should be connected to its TK/SS pin. This channel is in the shutdown state if its RUN pin voltage is below 1.2V. Its TK/SS pin is actively pulled to ground in this shutdown state.

Once the RUN pin voltage is above 1.2V, the channel powers up. A soft-start current of  $1.3\mu A$  then starts to charge its soft-start capacitor. Note that soft-start or tracking is achieved not by limiting the maximum output current of the controller but by controlling the output ramp voltage according to the ramp rate on the TK/SS pin. Current foldback is disabled during this phase to ensure smooth soft-start or tracking. The soft-start or tracking range is defined to be the voltage range from 0V to 0.6V on the TK/SS pin. The total soft-start time can be calculated as:

$$t_{SOFTSTART} = 0.6 \cdot \frac{C_{SS}}{1.3\mu A}$$

Regardless of the mode selected by the MODE/PLLIN pin, the regulator will always start in pulse-skipping mode up to  $TK/SS = 0.5V$ . Between  $TK/SS = 0.5V$  and  $0.54V$ , it will operate in forced continuous mode and revert to the selected mode once  $TK/SS > 0.54V$ . The output ripple is minimized during the 40mV forced continuous mode window ensuring a clean PGOOD signal.

When the channel is configured to track another supply, the feedback voltage of the other supply is duplicated by a resistor divider and applied to the TK/SS pin. Therefore, the voltage ramp rate on this pin is determined by the ramp rate of the other supply's voltage. Note that the small soft-start capacitor charging current is always flowing, producing a small offset error. To minimize this error, select the tracking resistive divider value to be small enough to make this error negligible.

In order to track down another channel or supply after the soft-start phase expires, the LTC3865/LTC3865-1 are forced into continuous mode of operation as soon as  $V_{FB}$  is below the undervoltage threshold of 0.54V regardless of the setting on the MODE/PLLIN pin. However, the LTC3865/LTC3865-1 should always be set in force continuous mode tracking down when there is no load. After  $TK/SS$  drops below 0.1V, the corresponding channel will operate in discontinuous mode.

### Output Voltage Tracking

The LTC3865/LTC3865-1 allow the user to program how its output ramps up and down by means of the TK/SS pins. Through these pins, the output can be set up to either coincidentally or ratiometrically track another supply's output, as shown in Figure 5. In the following discussions,  $V_{OUT1}$  refers to the LTC3865/LTC3865-1's output 1 as a master channel and  $V_{OUT2}$  refers to the LTC3865/LTC3865-1's output 2 as a slave channel. In practice, though, either phase can be used as the master. To implement the coincident tracking in Figure 5a, connect an additional resistive divider to  $V_{OUT1}$  and connect its midpoint to the TK/SS pin of the slave channel. The ratio of this divider should be the same as that of the slave channel's internal feedback divider

APPLICATIONS INFORMATION

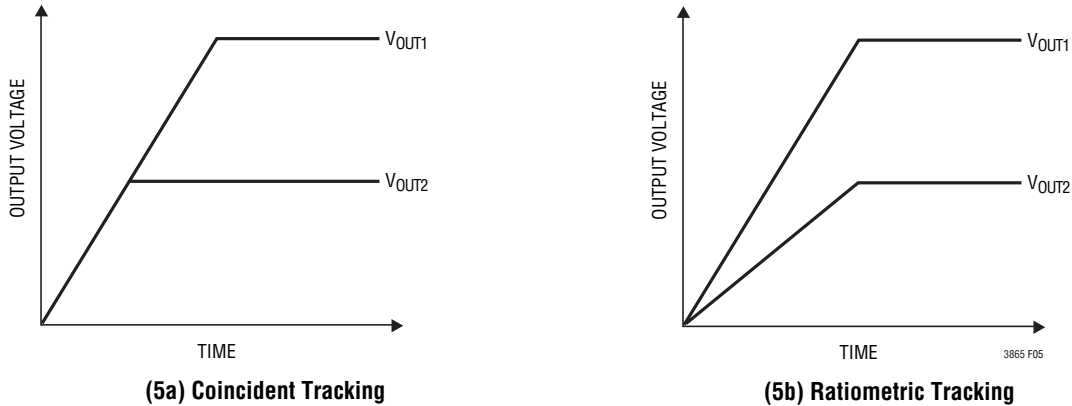

Figure 5. Two Different Modes of Output Voltage Tracking

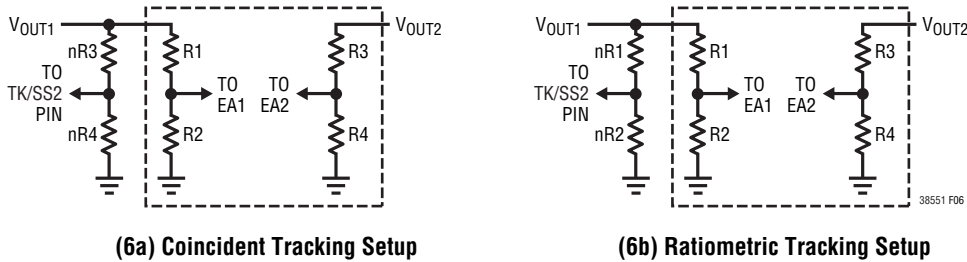

Figure 6. Setup for Coincident and Ratiometric Tracking

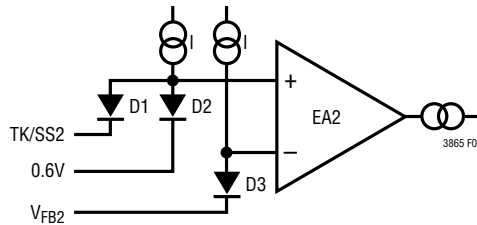

Figure 7. Equivalent Input Circuit of Error Amplifier

shown in Figure 6a. In this tracking mode,  $V_{OUT1}$  must be set higher than  $V_{OUT2}$ . To implement the ratiometric tracking, the ratio of the  $V_{OUT2}$  divider should be exactly the same as the master channel’s internal feedback divider. By selecting different resistors, the LTC3865/LTC3865-1 can achieve different modes of tracking including the two in Figure 5.

So which mode should be programmed? The coincident mode offers better output regulation. This can be better understood with the help of Figure 7. At the input stage of the slave channel’s error amplifier, two common anode diodes are used to clamp the equivalent reference

voltage and an additional diode is used to match the shifted common mode voltage. The top two current sources are of the same magnitude. In coincident mode, the TK/SS voltage is substantially higher than 0.6V at steady state and effectively turns off D1. D2 and D3 will therefore conduct the same current and offer tight matching between  $V_{FB2}$  and the internal precision 0.6V at steady state. In the ratiometric mode, however, TK/SS equals 0.6V at steady state. D1 will divert part of the bias current to make  $V_{FB2}$  slightly lower than 0.6V. Although this error is minimized by the exponential I-V characteristics of the diode, it does impose a finite amount of output voltage deviation.

## APPLICATIONS INFORMATION

When the master channel's output experiences dynamic excursion (under load transient, for example), the slave channel output will be affected as well. For better output regulation, use the coincident tracking mode instead of ratiometric.

### INTV<sub>CC</sub> Regulators and EXTV<sub>CC</sub>

The LTC3865 features a true PMOS LDO that supplies power to INTV<sub>CC</sub> from the V<sub>IN</sub> supply. INTV<sub>CC</sub> powers the gate drivers and much of the LTC3865/LTC3865-1's internal circuitry. The linear regulator regulates the voltage at the INTV<sub>CC</sub> pin to 5V when V<sub>IN</sub> is greater than 5.5V. EXTV<sub>CC</sub> connects to INTV<sub>CC</sub> through a P-channel MOSFET and can supply the needed power when its voltage is higher than 4.7V. Each of these can supply a peak current of 80mA and must be bypassed to ground with a minimum of 4.7μF ceramic capacitor or low ESR electrolytic capacitor. No matter what type of bulk capacitor is used, an additional 0.1μF ceramic capacitor placed directly adjacent to the INTV<sub>CC</sub> and PGND pins is highly recommended. Good bypassing is needed to supply the high transient currents required by the MOSFET gate drivers and to prevent interaction between channels.

High input voltage applications in which large MOSFETs are being driven at high frequencies may cause the maximum junction temperature rating for the LTC3865/LTC3865-1 to be exceeded. The INTV<sub>CC</sub> current, which is dominated by the gate charge current, may be supplied by either the 5V linear regulator or EXTV<sub>CC</sub>. When the voltage on the EXTV<sub>CC</sub> pin is less than 4.7V, the linear regulator is enabled. Power dissipation for the IC in this case is highest and is equal to V<sub>IN</sub> • I<sub>INTVCC</sub>. The gate charge current is dependent on operating frequency as discussed in the Efficiency Considerations section. The junction temperature can be estimated by using the equations given in Note 3 of the Electrical Characteristics. For example, the LTC3865 INTV<sub>CC</sub> current is limited to less than 42mA from a 38V supply in the UH package and not using the EXTV<sub>CC</sub> supply:

$$T_J = 70^\circ\text{C} + (42\text{mA})(38\text{V})(34^\circ\text{C/W}) = 125^\circ\text{C}$$

To prevent the maximum junction temperature from being exceeded, the input supply current must be checked while operating in continuous conduction mode (MODE/PLLIN = SGND) at maximum V<sub>IN</sub>. When the voltage applied to

EXTV<sub>CC</sub> rises above 4.7V, the INTV<sub>CC</sub> linear regulator is turned off and the EXTV<sub>CC</sub> is connected to the INTV<sub>CC</sub>. The EXTV<sub>CC</sub> remains on as long as the voltage applied to EXTV<sub>CC</sub> remains above 4.5V. Using the EXTV<sub>CC</sub> allows the MOSFET driver and control power to be derived from one of the LTC3865/LTC3865-1's switching regulator outputs during normal operation and from the INTV<sub>CC</sub> when the output is out of regulation (e.g., start-up, short-circuit). If more current is required through the EXTV<sub>CC</sub> than is specified, an external Schottky diode can be added between the EXTV<sub>CC</sub> and INTV<sub>CC</sub> pins. Do not apply more than 6V to the EXTV<sub>CC</sub> pin and make sure that EXTV<sub>CC</sub> < V<sub>IN</sub>.

Significant efficiency and thermal gains can be realized by powering INTV<sub>CC</sub> from the output, since the V<sub>IN</sub> current resulting from the driver and control currents will be scaled by a factor of (Duty Cycle)/(Switcher Efficiency).

Tying the EXTV<sub>CC</sub> pin to a 5V supply reduces the junction temperature in the previous example from 125°C to:

$$T_J = 70^\circ\text{C} + (42\text{mA})(5\text{V})(34^\circ\text{C/W}) = 77^\circ\text{C}$$

However, for 3.3V and other low voltage outputs, additional circuitry is required to derive INTV<sub>CC</sub> power from the output.

The following list summarizes the four possible connections for EXTV<sub>CC</sub>:

1. EXTV<sub>CC</sub> left open (or grounded). This will cause INTV<sub>CC</sub> to be powered from the internal 5V regulator resulting in an efficiency penalty of up to 10% at high input voltages.
2. EXTV<sub>CC</sub> connected directly to V<sub>OUT</sub>. This is the normal connection for a 5V regulator and provides the highest efficiency.
3. EXTV<sub>CC</sub> connected to an external supply. If a 5V external supply is available, it may be used to power EXTV<sub>CC</sub> providing it is compatible with the MOSFET gate drive requirements.
4. EXTV<sub>CC</sub> connected to an output-derived boost network. For 3.3V and other low voltage regulators, efficiency gains can still be realized by connecting EXTV<sub>CC</sub> to an output-derived voltage that has been boosted to greater than 4.7V.



## APPLICATIONS INFORMATION

For applications where the main input power is below 5V, tie the  $V_{IN}$  and  $INTV_{CC}$  pins together and tie the combined pins to the 5V input with a  $1\Omega$  or  $2.2\Omega$  resistor as shown in Figure 8 to minimize the voltage drop caused by the gate charge current. This will override the  $INTV_{CC}$  linear regulator and will prevent  $INTV_{CC}$  from dropping too low due to the dropout voltage. Make sure the  $INTV_{CC}$  voltage is at or exceeds the  $R_{DS(ON)}$  test voltage for the MOSFET which is typically 4.5V for logic-level devices.

### Topside MOSFET Driver Supply ( $C_B$ , $D_B$ )

External bootstrap capacitors,  $C_B$ , connected to the BOOST pins supply the gate drive voltages for the topside MOSFETs. Capacitor  $C_B$  in the Functional Diagram is charged through external diode  $D_B$  from  $INTV_{CC}$  when the SW pin is low. When one of the topside MOSFETs is to be turned on, the driver places the  $C_B$  voltage across the gate source of the desired MOSFET. This enhances the MOSFET and turns on the topside switch. The switch node voltage, SW, rises to  $V_{IN}$  and the BOOST pin follows. With the topside MOSFET on, the boost voltage is above the input supply:  $V_{BOOST} = V_{IN} + V_{INTV_{CC}}$ . The value of the boost capacitor,  $C_B$ , needs to be 100 times that of the total input capacitance of the topside MOSFET(s). The reverse breakdown of the external Schottky diode must be greater than  $V_{IN(MAX)}$ . When adjusting the gate drive level, the final arbiter is the total input current for the regulator. If a change is made and the input current decreases, then the efficiency has improved. If there is no change in input current, then there is no change in efficiency.

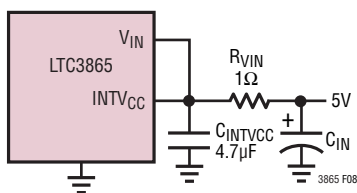

Figure 8. Setup for a 5V Input

### Undervoltage Lockout

The LTC3865/LTC3865-1 have two functions that help protect the controller in case of undervoltage conditions. A precision UVLO comparator constantly monitors the  $INTV_{CC}$  voltage to ensure that an adequate gate-drive voltage is present. It locks out the switching action when  $INTV_{CC}$  is below 3.3V. To prevent oscillation when there is a disturbance on the  $INTV_{CC}$ , the UVLO comparator has 550mV of precision hysteresis.

Another way to detect an undervoltage condition is to monitor the  $V_{IN}$  supply. Because the RUN pins have a precision turn-on reference of 1.2V, one can use a resistor divider to  $V_{IN}$  to turn on the IC when  $V_{IN}$  is high enough. An extra 4.5 $\mu$ A of current flows out of the RUN pin once the RUN pin voltage passes 1.2V. One can program the hysteresis of the run comparator by adjusting the values of the resistive divider. For accurate  $V_{IN}$  undervoltage detection,  $V_{IN}$  needs to be higher than 4.5V.

### $C_{IN}$ and $C_{OUT}$ Selection

The selection of  $C_{IN}$  is simplified by the 2-phase architecture and its impact on the worst-case RMS current drawn through the input network (battery/fuse/capacitor). It can be shown that the worst-case capacitor RMS current occurs when only one controller is operating. The controller with the highest  $(V_{OUT})(I_{OUT})$  product needs to be used in the formula below to determine the maximum RMS capacitor current requirement. Increasing the output current drawn from the other controller will actually decrease the input RMS ripple current from its maximum value. The out-of-phase technique typically reduces the input capacitor's RMS ripple current by a factor of 30% to 70% when compared to a single phase power supply solution.

In continuous mode, the source current of the top MOSFET is a square wave of duty cycle  $(V_{OUT})/(V_{IN})$ . To prevent large voltage transients, a low ESR capacitor sized for the

## APPLICATIONS INFORMATION

maximum RMS current of one channel must be used. The maximum RMS capacitor current is given by:

$$C_{IN} \text{ Required } I_{RMS} \approx \frac{I_{MAX}}{V_{IN}} [(V_{OUT})(V_{IN} - V_{OUT})]^{1/2}$$

This formula has a maximum at  $V_{IN} = 2V_{OUT}$ , where  $I_{RMS} = I_{OUT}/2$ . This simple worst-case condition is commonly used for design because even significant deviations do not offer much relief. Note that capacitor manufacturers' ripple current ratings are often based on only 2000 hours of life. This makes it advisable to further derate the capacitor, or to choose a capacitor rated at a higher temperature than required. Several capacitors may be paralleled to meet size or height requirements in the design. Due to the high operating frequency of the LTC3865, ceramic capacitors can also be used for  $C_{IN}$ . Always consult the manufacturer if there is any question.

The benefit of the LTC3865/LTC3865-1 2-phase operation can be calculated by using the equation above for the higher power controller and then calculating the loss that would have resulted if both controller channels switched on at the same time. The total RMS power lost is lower when both controllers are operating due to the reduced overlap of current pulses required through the input capacitor's ESR. This is why the input capacitor's requirement calculated above for the worst-case controller is adequate for the dual controller design. Also, the input protection fuse resistance, battery resistance, and PC board trace resistance losses are also reduced due to the reduced peak currents in a 2-phase system. The overall benefit of a multiphase design will only be fully realized when the source impedance of the power supply/battery is included in the efficiency testing. The sources of the top MOSFETs should be placed within 1 cm of each other and share a common  $C_{IN}(s)$ . Separating the sources and  $C_{IN}$  may produce undesirable voltage and current resonances at  $V_{IN}$ .

A small (0.1  $\mu$ F to 1  $\mu$ F) bypass capacitor between the chip  $V_{IN}$  pin and ground, placed close to the LTC3865/LTC3865-1, is also suggested. A 2.2  $\Omega$  to 10  $\Omega$  resistor placed between  $C_{IN}$  (C1) and the  $V_{IN}$  pin provides further isolation between the two channels.

The selection of  $C_{OUT}$  is driven by the effective series resistance (ESR). Typically, once the ESR requirement is satisfied, the capacitance is adequate for filtering. The output ripple ( $\Delta V_{OUT}$ ) is approximated by:

$$\Delta V_{OUT} \approx I_{RIPPLE} \left( ESR + \frac{1}{8fC_{OUT}} \right)$$

where  $f$  is the operating frequency,  $C_{OUT}$  is the output capacitance and  $I_{RIPPLE}$  is the ripple current in the inductor. The output ripple is highest at maximum input voltage since  $I_{RIPPLE}$  increases with input voltage.

### Setting Output Voltage

The LTC3865/LTC3865-1 output voltages are each set by the voltages at VID pins. Each of the VID pins can be floated, or  $INTV_{CC}$  or grounded, depending on what preset voltages are needed at the output (Table 1).

If the desired output voltage is not one of the preset values, select 0.6V and use 1% resistors to divide  $V_{OUT}$ , as shown in Figure 9. The regulated output voltage is determined by:

$$V_{OUT} = 0.6V \cdot \left( 1 + \frac{R_B}{R_A} \right)$$

To improve the frequency response, a feed-forward capacitor,  $C_{FF}$ , may be used. Great care should be taken to route the  $V_{OSENSE}$  line away from noise sources, such as the inductor or the SW line.

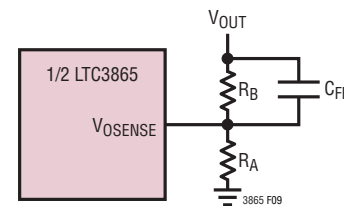

Figure 9. Setting Output Voltage

## APPLICATIONS INFORMATION

### Fault Conditions: Current Limit and Current Foldback

The LTC3865/LTC3865-1 include current foldback to help limit load current when the output is shorted to ground. If the output falls below 50% of its nominal output level, then the maximum sense voltage is progressively lowered from its maximum programmed value to one-third of the maximum value. Foldback current limiting is disabled during the soft-start or tracking up. Under short-circuit conditions with very low duty cycles, the LTC3865 will begin cycle skipping in order to limit the short-circuit current. In this situation the bottom MOSFET will be dissipating most of the power but less than in normal operation. The short-circuit ripple current is determined by the minimum on-time  $t_{ON(MIN)}$  of the LTC3865/LTC3865-1 ( $\approx 90\text{ns}$ ), the input voltage and inductor value:

$$\Delta I_{L(SC)} = t_{ON(MIN)} \cdot \frac{V_{IN}}{L}$$

The resulting short-circuit current is:

$$I_{SC} = \frac{1/3 V_{SENSE(MAX)}}{R_{SENSE}} - \frac{1}{2} \Delta I_{L(SC)}$$

### Phase-Locked Loop and Frequency Synchronization

The LTC3865/LTC3865-1 have a phase-locked loop (PLL) comprised of an internal voltage-controlled oscillator ( $V_{CO}$ ) and a phase detector. This allows the turn-on of the top

MOSFET of controller 1 to be locked to the rising edge of an external clock signal applied to the MODE/PLLIN pin. The turn-on of controller 2's top MOSFET is thus 180 degrees out-of-phase with the external clock. The phase detector is an edge sensitive digital type that provides zero degrees phase shift between the external and internal oscillators. This type of phase detector does not exhibit false lock to harmonics of the external clock.

The output of the phase detector is a pair of complementary current sources that charge or discharge the internal filter network. There is a precision  $7.5\mu\text{A}$  of current flowing out of FREQ pin. This allows the user to use a single resistor to SGND to set the switching frequency when no external clock is applied to the MODE/PLLIN pin. The internal switch between FREQ pin and the integrated PLL filter network is on, allowing the filter network to be at the same voltage potential as of FREQ pin. The relationship between the voltage on the FREQ pin and the operating frequency is shown in Figure 10 and specified in the Electrical Characteristic table. If an external clock is detected on the MODE/PLLIN pin, the internal switch mentioned above will turn off and isolate the influence of FREQ pin. Note that the LTC3865 can only be synchronized to an external clock whose frequency is within range of the LTC3865/LTC3865-1's internal  $V_{CO}$ . This is guaranteed to be between 250kHz and 770kHz. A simplified block diagram is shown in Figure 11.

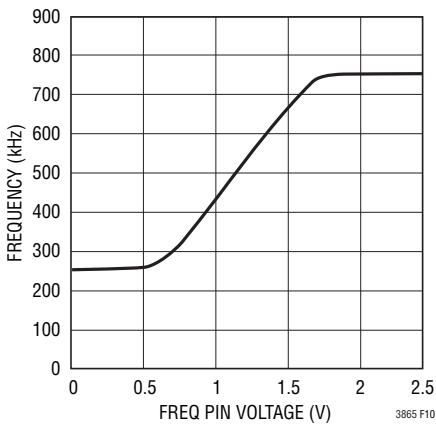

Figure 10. Relationship Between Oscillator Frequency and Voltage at the FREQ Pin

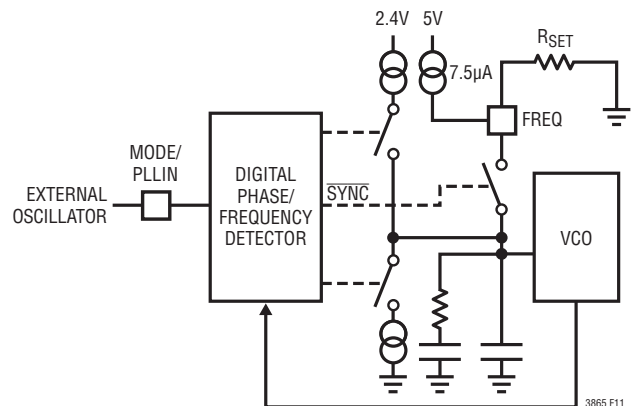

Figure 11. Phase-Locked Loop Block Diagram



## APPLICATIONS INFORMATION

If the external clock frequency is greater than the internal oscillator's frequency,  $f_{OSC}$ , then current is sourced continuously from the phase detector output, pulling up the filter network. When the external clock frequency is less than  $f_{OSC}$ , current is sunk continuously, pulling down the filter network. If the external and internal frequencies are the same but exhibit a phase difference, the current sources turn on for an amount of time corresponding to the phase difference. The voltage on the filter network is adjusted until the phase and frequency of the internal and external oscillators are identical. At the stable operating point, the phase detector output is high impedance and the filter capacitor holds the voltage.

Typically, the external clock (on MODE/PLLIN pin) input high threshold is 1.6V, while the input low threshold is 1V. The external clock should not be applied when the IC is in shutdown.

### Minimum On-Time Considerations

Minimum on-time,  $t_{ON(MIN)}$ , is the smallest time duration that the LTC3865/LTC3865-1 is capable of turning on the top MOSFET. It is determined by internal timing delays and the gate charge required to turn on the top MOSFET. Low duty cycle applications may approach this minimum on-time limit and care should be taken to ensure that

$$t_{ON(MIN)} < \frac{V_{OUT}}{V_{IN}(f)}$$

If the duty cycle falls below what can be accommodated by the minimum on-time, the controller will begin to skip cycles. The output voltage will continue to be regulated, but the ripple voltage and current will increase.

The minimum on-time for the LTC3865/LTC3865-1 is approximately 90ns, with reasonably good PCB layout, minimum 30% inductor current ripple and at least 10mV to 15mV ripple on the current sense signal. The minimum on-time can be affected by PCB switching noise in the voltage and current loop. As the peak sense voltage

decreases the minimum on-time gradually increases to 130ns. This is of particular concern in forced continuous applications with low ripple current at light loads. If the duty cycle drops below the minimum on-time limit in this situation, a significant amount of cycle skipping can occur with correspondingly larger current and voltage ripple.

### Efficiency Considerations

The percent efficiency of a switching regulator is equal to the output power divided by the input power times 100%. It is often useful to analyze individual losses to determine what is limiting the efficiency and which change would produce the most improvement. Percent efficiency can be expressed as:

$$\% \text{Efficiency} = 100\% - (L1 + L2 + L3 + \dots)$$

where L1, L2, etc. are the individual losses as a percentage of input power.

Although all dissipative elements in the circuit produce losses, four main sources usually account for most of the losses in LTC3865/LTC3865-1 circuits: 1) IC  $V_{IN}$  current, 2)  $INTV_{CC}$  regulator current, 3)  $I^2R$  losses, 4) Topside MOSFET transition losses.

1. The  $V_{IN}$  current is the DC supply current given in the Electrical Characteristics table, which excludes MOSFET driver and control currents.  $V_{IN}$  current typically results in a small (<0.1%) loss.
2.  $INTV_{CC}$  current is the sum of the MOSFET driver and control currents. The MOSFET driver current results from switching the gate capacitance of the power MOSFETs. Each time a MOSFET gate is switched from low to high to low again, a packet of charge  $dQ$  moves from  $INTV_{CC}$  to ground. The resulting  $dQ/dt$  is a current out of  $INTV_{CC}$  that is typically much larger than the control circuit current. In continuous mode,  $I_{GATECHG} = f(Q_T + Q_B)$ , where  $Q_T$  and  $Q_B$  are the gate charges of the topside and bottom side MOSFETs.

## APPLICATIONS INFORMATION

Supplying  $INTV_{CC}$  power through  $EXTV_{CC}$  from an output-derived source will scale the  $V_{IN}$  current required for the driver and control circuits by a factor of (Duty Cycle)/(Efficiency). For example, in a 20V to 5V application, 10mA of  $INTV_{CC}$  current results in approximately 2.5mA of  $V_{IN}$  current. This reduces the mid-current loss from 10% or more (if the driver was powered directly from  $V_{IN}$ ) to only a few percent.

- $I^2R$  losses are predicted from the DC resistances of the fuse (if used), MOSFET, inductor, current sense resistor. In continuous mode, the average output current flows through L and  $R_{SENSE}$ , but is “chopped” between the topside MOSFET and the synchronous MOSFET. If the two MOSFETs have approximately the same  $R_{DS(ON)}$ , then the resistance of one MOSFET can simply be summed with the resistances of L and  $R_{SENSE}$  to obtain  $I^2R$  losses. For example, if each  $R_{DS(ON)} = 10m\Omega$ ,  $R_L = 10m\Omega$ ,  $R_{SENSE} = 5m\Omega$ , then the total resistance is  $25m\Omega$ . This results in losses ranging from 2% to 8% as the output current increases from 3A to 15A for a 5V output, or a 3% to 12% loss for a 3.3V output. Efficiency varies as the inverse square of  $V_{OUT}$  for the same external components and output power level. The combined effects of increasingly lower output voltages and higher currents required by high performance digital systems is not doubling but quadrupling the importance of loss terms in the switching regulator system!
- Transition losses apply only to the topside MOSFET(s), and become significant only when operating at high input voltages (typically 15V or greater). Transition losses can be estimated from:

$$\text{Transition Loss} = (1.7) V_{IN}^2 I_{O(MAX)} C_{RSS} f$$

Other “hidden” losses such as copper trace and internal battery resistances can account for an additional 5% to 10% efficiency degradation in portable systems. It is

very important to include these “system” level losses during the design phase. The internal battery and fuse resistance losses can be minimized by making sure that  $C_{IN}$  has adequate charge storage and very low ESR at the switching frequency. A 25W supply will typically require a minimum of 20 $\mu$ F to 40 $\mu$ F of capacitance having a maximum of 20m $\Omega$  to 50m $\Omega$  of ESR. The LTC3865 2-phase architecture typically halves this input capacitance requirement over competing solutions. Other losses including Schottky conduction losses during dead time and inductor core losses generally account for less than 2% total additional loss.

### Checking Transient Response

The regulator loop response can be checked by looking at the load current transient response. Switching regulators take several cycles to respond to a step in DC (resistive) load current. When a load step occurs,  $V_{OUT}$  shifts by an amount equal to  $\Delta I_{LOAD}$  (ESR), where ESR is the effective series resistance of  $C_{OUT}$ .  $\Delta I_{LOAD}$  also begins to charge or discharge  $C_{OUT}$  generating the feedback error signal that forces the regulator to adapt to the current change and return  $V_{OUT}$  to its steady-state value. During this recovery time  $V_{OUT}$  can be monitored for excessive overshoot or ringing, which would indicate a stability problem. The availability of the  $I_{TH}$  pin not only allows optimization of control loop behavior but also provides a DC coupled and AC filtered closed loop response test point. The DC step, rise time and settling at this test point truly reflects the closed loop response. Assuming a predominantly second order system, phase margin and/or damping factor can be estimated using the percentage of overshoot seen at this pin. The bandwidth can also be estimated by examining the rise time at the pin. The  $I_{TH}$  external components shown in the Typical Application circuit will provide an adequate starting point for most applications.

## APPLICATIONS INFORMATION

The  $I_{TH}$  series  $R_C$ - $C_C$  filter sets the dominant pole-zero loop compensation. The values can be modified slightly (from 0.5 to 2 times their suggested values) to optimize transient response once the final PC layout is done and the particular output capacitor type and value have been determined. The output capacitors need to be selected because the various types and values determine the loop gain and phase. An output current pulse of 20% to 80% of full-load current having a rise time of  $1\mu\text{s}$  to  $10\mu\text{s}$  will produce output voltage and  $I_{TH}$  pin waveforms that will give a sense of the overall loop stability without breaking the feedback loop. Placing a power MOSFET directly across the output capacitor and driving the gate with an appropriate signal generator is a practical way to produce a realistic load step condition. The initial output voltage step resulting from the step change in output current may not be within the bandwidth of the feedback loop, so this signal cannot be used to determine phase margin. This is why it is better to look at the  $I_{TH}$  pin signal which is in the feedback loop and is the filtered and compensated control loop response. The gain of the loop will be increased by increasing  $R_C$  and the bandwidth of the loop will be increased by decreasing  $C_C$ . If  $R_C$  is increased by the same factor that  $C_C$  is decreased, the zero frequency will be kept the same, thereby keeping the phase shift the same in the most critical frequency range of the feedback loop. The output voltage settling behavior is related to the stability of the closed-loop system and will demonstrate the actual overall supply performance.

A second, more severe transient is caused by switching in loads with large ( $>1\mu\text{F}$ ) supply bypass capacitors. The discharged bypass capacitors are effectively put in parallel with  $C_{OUT}$ , causing a rapid drop in  $V_{OUT}$ . No regulator can alter its delivery of current quickly enough to prevent this sudden step change in output voltage if the load switch resistance is low and it is driven quickly. If the ratio of  $C_{LOAD}$  to  $C_{OUT}$  is greater than 1:50, the switch rise time should be controlled so that the load rise time is limited to approximately  $25 \cdot C_{LOAD}$ . Thus a  $10\mu\text{F}$  capacitor would require a  $250\mu\text{s}$  rise time, limiting the charging current to about 200mA.

### PC Board Layout Checklist

When laying out the printed circuit board, the following checklist should be used to ensure proper operation of the IC. These items are also illustrated graphically in the layout diagram of Figure 12. Figure 13 illustrates the current waveforms present in the various branches of the 2-phase synchronous regulators operating in the continuous mode. Check the following in your layout:

1. Are the top N-channel MOSFETs M1 and M3 located within 1 cm of each other with a common drain connection at  $C_{IN}$ ? Do not attempt to split the input decoupling for the two channels as it can cause a large resonant loop.
2. Are the signal and power grounds kept separate? The combined IC signal ground pin and the ground return of  $C_{INTVCC}$  must return to the combined  $C_{OUT}$  (-) terminals. The  $V_{OSENSE}$  and  $I_{TH}$  traces should be as short as possible. The path formed by the top N-channel MOSFET, Schottky diode and the  $C_{IN}$  capacitor should have short leads and PC trace lengths. The output capacitor (-) terminals should be connected as close as possible to the (-) terminals of the input capacitor by placing the capacitors next to each other and away from the Schottky loop described above.
3. Do the LTC3865  $V_{OSENSE}$  pins connect to the (+) terminals of  $C_{OUT}$ ? The connections between the  $V_{OSENSE}$  pins and  $C_{OUT}$  should not be along the high current input feeds from the input capacitor(s).
4. Are the  $SENSE^+$  and  $SENSE^-$  leads routed together with minimum PC trace spacing? The filter capacitor between  $SENSE^+$  and  $SENSE^-$  should be as close as possible to the IC. Ensure accurate current sensing with Kelvin connections at the sense resistor or inductor, whichever is used for current sensing.
5. Is the  $INTV_{CC}$  decoupling capacitor connected close to the IC, between the  $INTV_{CC}$  and the power ground pins? This capacitor carries the MOSFET drivers current peaks. An additional  $1\mu\text{F}$  ceramic capacitor placed immediately next to the  $INTV_{CC}$  and PGND pins can help improve noise performance substantially.

## APPLICATIONS INFORMATION

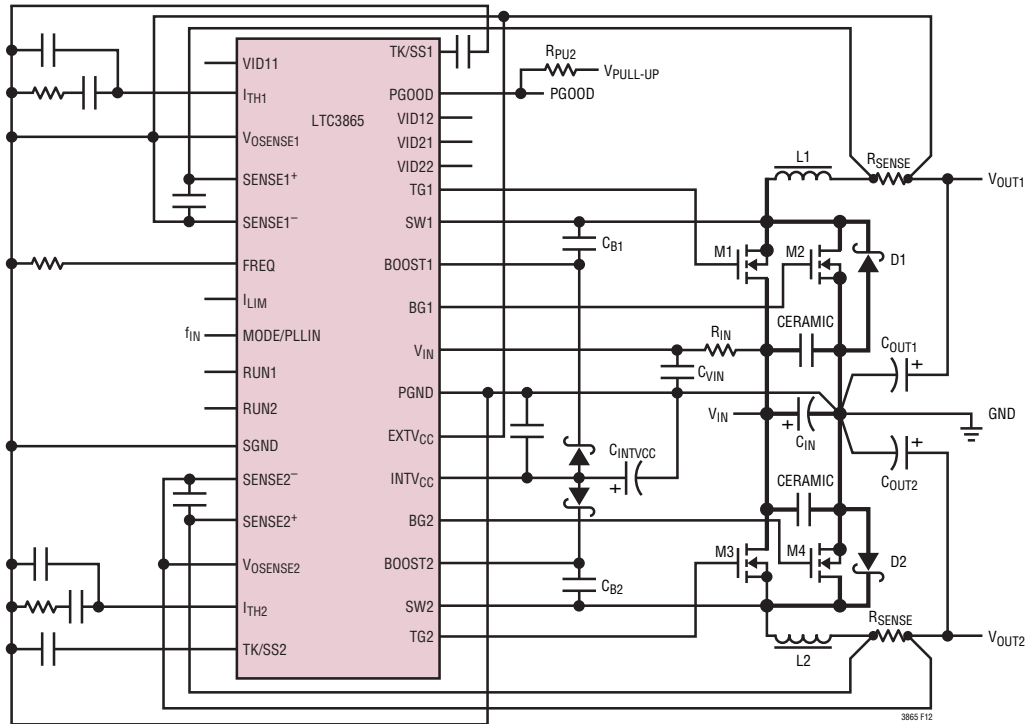

Figure 12. Recommended Printed Circuit Layout Diagram

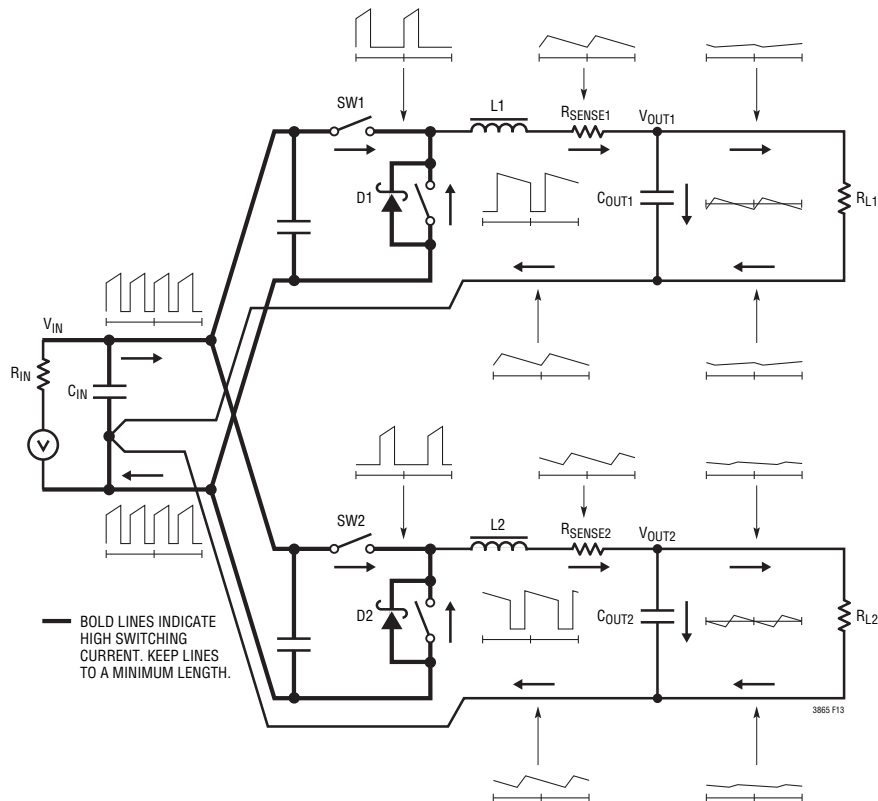

Figure 13. Branch Current Waveforms

## APPLICATIONS INFORMATION

- Keep the switching nodes (SW1, SW2), top gate nodes (TG1, TG2), and boost nodes (BOOST1, BOOST2) away from sensitive small-signal nodes, especially from the opposite channel's voltage and current sensing feedback pins. All of these nodes have very large and fast moving signals and therefore should be kept on the "output side" of the LTC3865/LTC3865-1 and occupy minimum PC trace area. If DCR sensing is used, place the top resistor (Figure 2b, R1) close to the switching node.
- Use a modified "star ground" technique: a low impedance, large copper area central grounding point on the same side of the PC board as the input and output capacitors with tie-ins for the bottom of the INTV<sub>CC</sub> decoupling capacitor, the bottom of the voltage feedback resistive divider and the SGND pin of the IC.

### PC Board Layout Debugging

Start with one controller at a time. It is helpful to use a DC-50MHz current probe to monitor the current in the inductor while testing the circuit. Monitor the output switching node (SW pin) to synchronize the oscilloscope to the internal oscillator and probe the actual output voltage as well. Check for proper performance over the operating voltage and current range expected in the application. The frequency of operation should be maintained over the input voltage range down to dropout and until the output load drops below the low current operation threshold—typically 10% of the maximum designed current level in Burst Mode operation.

The duty cycle percentage should be maintained from cycle to cycle in a well-designed, low noise PCB implementation. Variation in the duty cycle at a subharmonic rate

can suggest noise pickup at the current or voltage sensing inputs or inadequate loop compensation. Overcompensation of the loop can be used to tame a poor PC layout if regulator bandwidth optimization is not required. Only after each controller is checked for its individual performance should both controllers be turned on at the same time. A particularly difficult region of operation is when one controller channel is nearing its current comparator trip point when the other channel is turning on its top MOSFET. This occurs around 50% duty cycle on either channel due to the phasing of the internal clocks and may cause minor duty cycle jitter.

Reduce  $V_{IN}$  from its nominal level to verify operation of the regulator in dropout. Check the operation of the undervoltage lockout circuit by further lowering  $V_{IN}$  while monitoring the outputs to verify operation.

Investigate whether any problems exist only at higher output currents or only at higher input voltages. If problems coincide with high input voltages and low output currents, look for capacitive coupling between the BOOST, SW, TG, and possibly BG connections and the sensitive voltage and current pins. The capacitor placed across the current sensing pins needs to be placed immediately adjacent to the pins of the IC. This capacitor helps to minimize the effects of differential noise injection due to high frequency capacitive coupling. If problems are encountered with high current output loading at lower input voltages, look for inductive coupling between  $C_{IN}$ , Schottky and the top MOSFET components to the sensitive current and voltage sensing traces. In addition, investigate common ground path voltage pickup between these components and the SGND pin of the IC.



## APPLICATIONS INFORMATION

### Design Example

As a design example for a 2-channel medium current regulator, assume  $V_{IN} = 12V$  (nominal),  $V_{IN} = 20V$  (maximum),  $V_{OUT1} = 3.3V$ ,  $V_{OUT2} = 1.8V$ ,  $I_{MAX1,2} = 5A$ , and  $f = 500kHz$  (see Figure 14).

The regulated output voltages are set by connecting VID11 and VID22 to INTV<sub>CC</sub> and floating VID12 and VID21.

The frequency is set by biasing the FREQ pin to 1.2V (see Figure 9).

The inductance values are based on a 35% maximum ripple current assumption (1.75A for each channel). The highest value of ripple current occurs at the maximum input voltage:

$$L = \frac{V_{OUT}}{f \cdot \Delta I_L (MAX)} \left( 1 - \frac{V_{OUT}}{V_{IN (MAX)}} \right)$$

Channel 1 will require 3.2μH, and Channel 2 will require 1.9μH. The next highest standard values are 3.3μH and 2.2μH. At the nominal input voltage (12V), the ripple will be:

$$\Delta I_L (NOM) = \frac{V_{OUT}}{f \cdot L} \left( 1 - \frac{V_{OUT}}{V_{IN (NOM)}} \right)$$

Channel 1 will have 1.45A (29%) ripple, and Channel 2 will have 1.4A (28%) ripple. The peak inductor current will be the maximum DC value plus one-half the ripple current, or 5.725A for Channel 1 and 5.7A for Channel 2.

The minimum on-time occurs on Channel 1 at the maximum  $V_{IN}$ , and should not be less than 90ns:

$$t_{ON (MIN)} = \frac{V_{OUT}}{V_{IN (MAX)} \cdot f} = \frac{1.8V}{20V(500kHz)} = 180ns$$

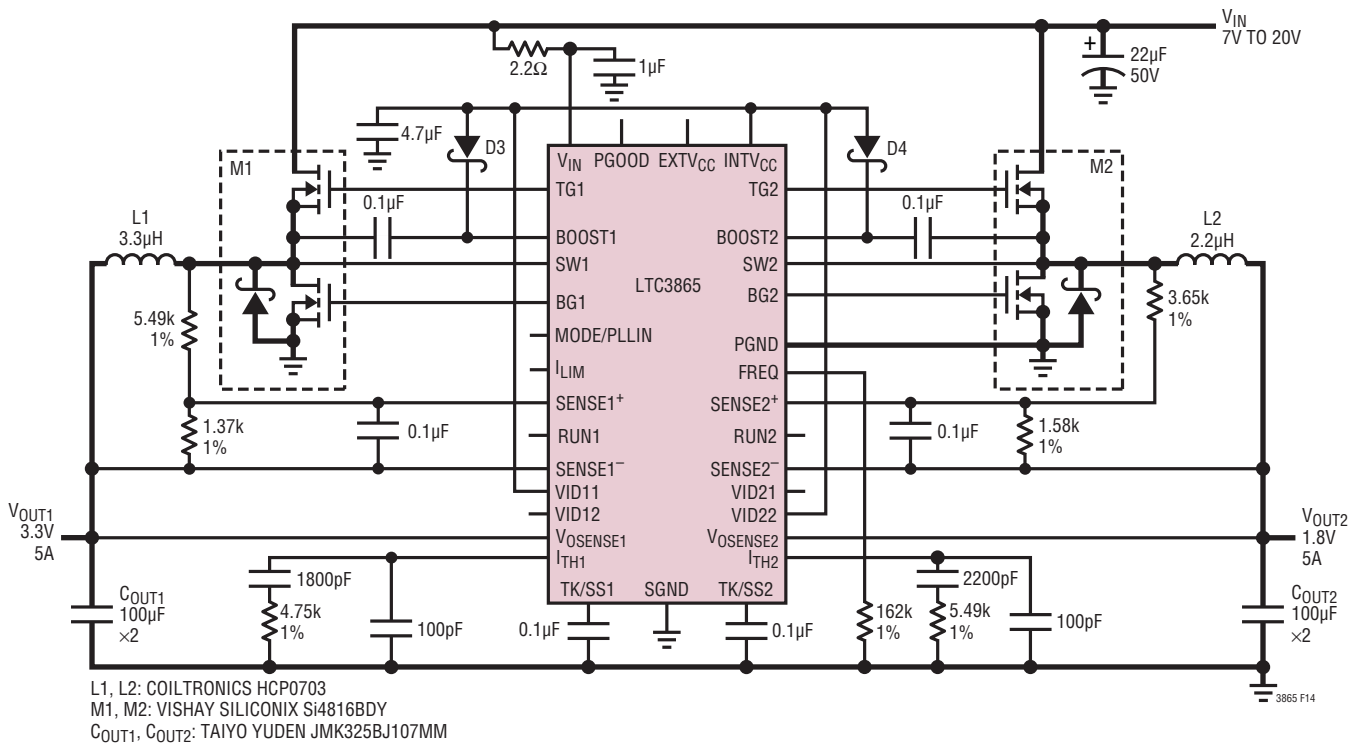

Figure 14. High Efficiency Dual 500kHz 3.3V/1.8V Step-Down Converter

## APPLICATIONS INFORMATION

With  $I_{LIM}$  floating, the equivalent  $R_{SENSE}$  resistor value can be calculated by using the minimum value for the maximum current sense threshold (44mV).

$$R_{SENSE(EQUIV)} = \frac{V_{SENSE(MIN)}}{I_{LOAD(MAX)} + \frac{\Delta I_{L(NOM)}}{2}}$$

$$= \frac{44mV}{5A + \frac{1.5A}{2}} \cong 7.7m\Omega$$

The equivalent  $R_{SENSE}$  is the same for Channel 2.

The Coiltronics (Cooper) HCP0703-2R2 (20m $\Omega$  DCR<sub>MAX</sub> at 20°C) and HCP0703-3R3 (30m $\Omega$  DCR<sub>MAX</sub> at 20°C) are chosen. At 100°C, the estimated maximum DCR values are 26.4m $\Omega$  and 39.6m $\Omega$ . The divider ratios are:

$$R_D = \frac{R_{SENSE(EQUIV)}}{DCR_{MAX} \text{ at } T_{L(MAX)}} = \frac{7.7m\Omega}{26.4m\Omega} = 0.3;$$

$$\text{and } \frac{7.7m\Omega}{39.6m\Omega} \cong 0.2$$

For each channel, 0.1 $\mu$ F is selected for C1.

$$R1||R2 = \frac{L}{(DCR_{MAX} \text{ at } 20^\circ\text{C}) \cdot C1} = \frac{2.2\mu\text{H}}{20m\Omega \cdot 0.1\mu\text{F}}$$

$$= 1.1k; \text{ and } \frac{3.3\mu\text{H}}{30m\Omega \cdot 0.1\mu\text{F}} = 1.1k$$

For channel 1, the DCR<sub>SENSE</sub> filter/divider values are:

$$R1 = \frac{R1||R2}{R_D} = \frac{1.1k}{0.2} \cong 5.5k;$$

$$R2 = \frac{R1 \cdot R_D}{1 - R_D} = \frac{5.5k \cdot 0.2}{1 - 0.2} \cong 1.37k$$

The power loss in R1 at the maximum input voltage is:

$$P_{LOSS R1} = \frac{(V_{IN(MAX)} - V_{OUT}) \cdot V_{OUT}}{R1}$$

$$= \frac{(20V - 3.3V) \cdot 3.3V}{5.5k} = 10mW$$

The respective values for Channel 2 are  $R1 = 3.66k$ ,  $R2 = 1.57k$ ; and  $P_{LOSS R1} = 8mW$ .

Burst Mode operation is chosen for high light load efficiency (Figure 15) by floating the MODE/PLLIN pin. Power loss due to the DCR sensing network is slightly higher at light loads than would have been the case with a suitable sense resistor (8m $\Omega$ ). At heavier loads, DCR sensing provides higher efficiency.

The power dissipation on the topside MOSFET can be easily estimated. Choosing a Siliconix Si4816BDY dual MOSFET results in:  $R_{DS(ON)} = 0.023\Omega/0.016\Omega$ ,  $C_{MILLER} \cong 100pF$ . At maximum input voltage with  $T(\text{estimated}) = 50^\circ\text{C}$ :

$$P_{MAIN} = \frac{3.3V}{20V} (5)^2 [1 + (0.005)(50^\circ\text{C} - 25^\circ\text{C})] \cdot$$

$$(0.023\Omega) + (20V)^2 \left( \frac{5A}{2} \right) (2\Omega) (100pF) \cdot$$

$$\left[ \frac{1}{5 - 2.3} + \frac{1}{2.3} \right] (500kHz) = 186mW$$

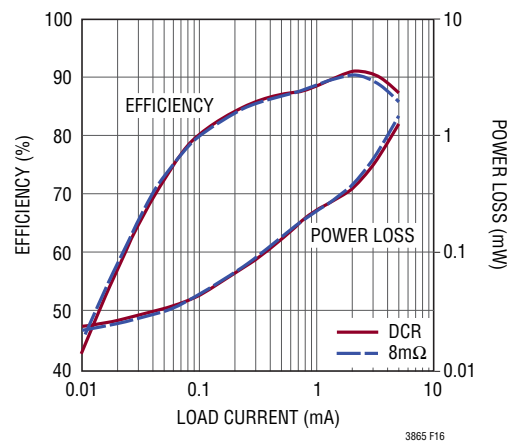

Figure 15. Design Example Efficiency vs Load

## APPLICATIONS INFORMATION

A short-circuit to ground will result in a folded back current of:

$$I_{SC} = \frac{(1/3)50\text{mV}}{0.008\Omega} - \frac{1}{2} \left( \frac{90\text{ns}(20\text{V})}{3.3\mu\text{H}} \right) = 1.8\text{A}$$

with a typical value of  $R_{DS(ON)}$  and  $\delta = (0.005/^\circ\text{C})(20) = 0.1$ . The resulting power dissipated in the bottom MOSFET is:

$$P_{\text{SYNC}} = \frac{20\text{V} - 3.3\text{V}}{20\text{V}} (1.8\text{A})^2 (1.125)(0.016\Omega) = 48\text{mW}$$

which is less than under full-load conditions.

$C_{IN}$  is chosen for an RMS current rating of at least 2A at temperature assuming only channel 1 or 2 is on.  $C_{OUT}$  is chosen with an ESR of  $0.02\Omega$  for low output ripple. The output ripple in continuous mode will be highest at the maximum input voltage. The output voltage ripple due to ESR is approximately:

$$V_{\text{ORIPPLE}} = R_{\text{ESR}} (\Delta I_L) = 0.02\Omega (1.5\text{A}) = 30\text{mV}_{\text{P-P}}$$

## TYPICAL APPLICATIONS

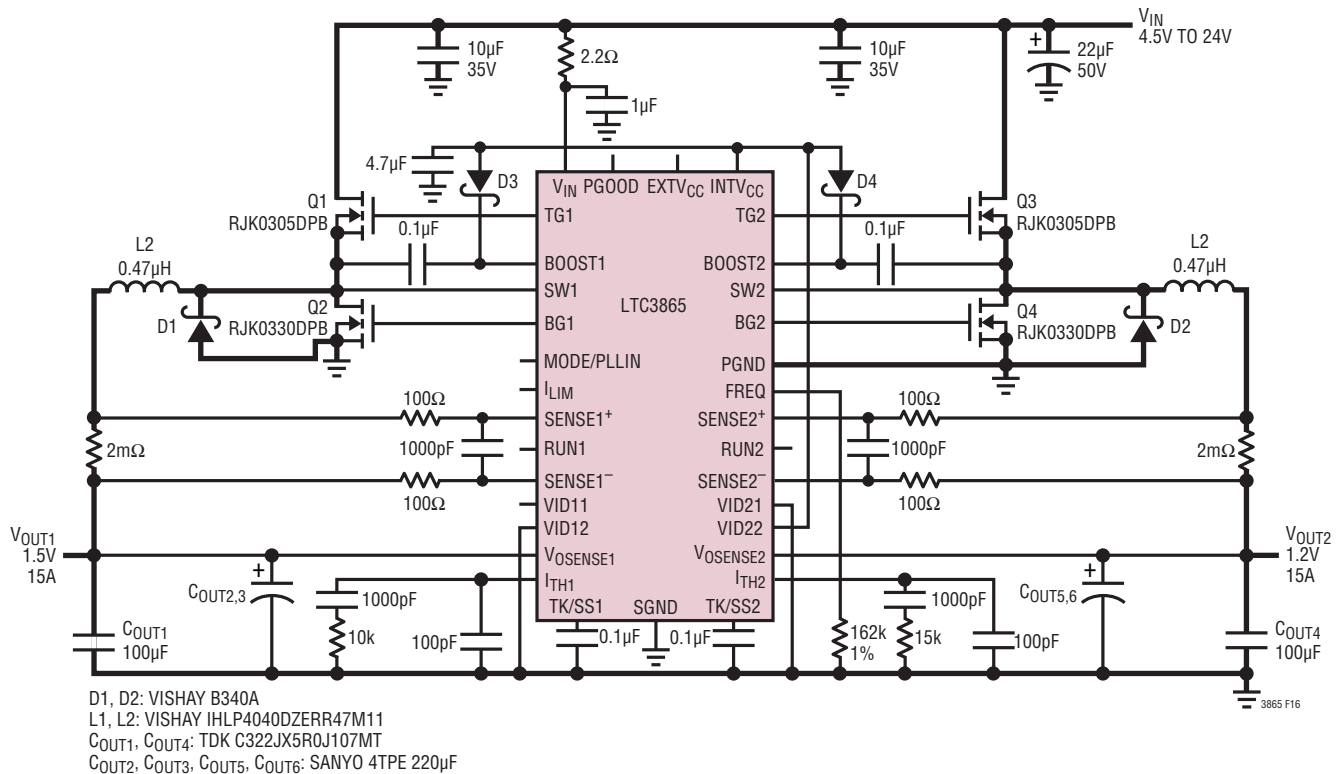

Figure 16. 1.5V/15A, 1.2V/15A Converter Using Sense Resistors



TYPICAL APPLICATIONS

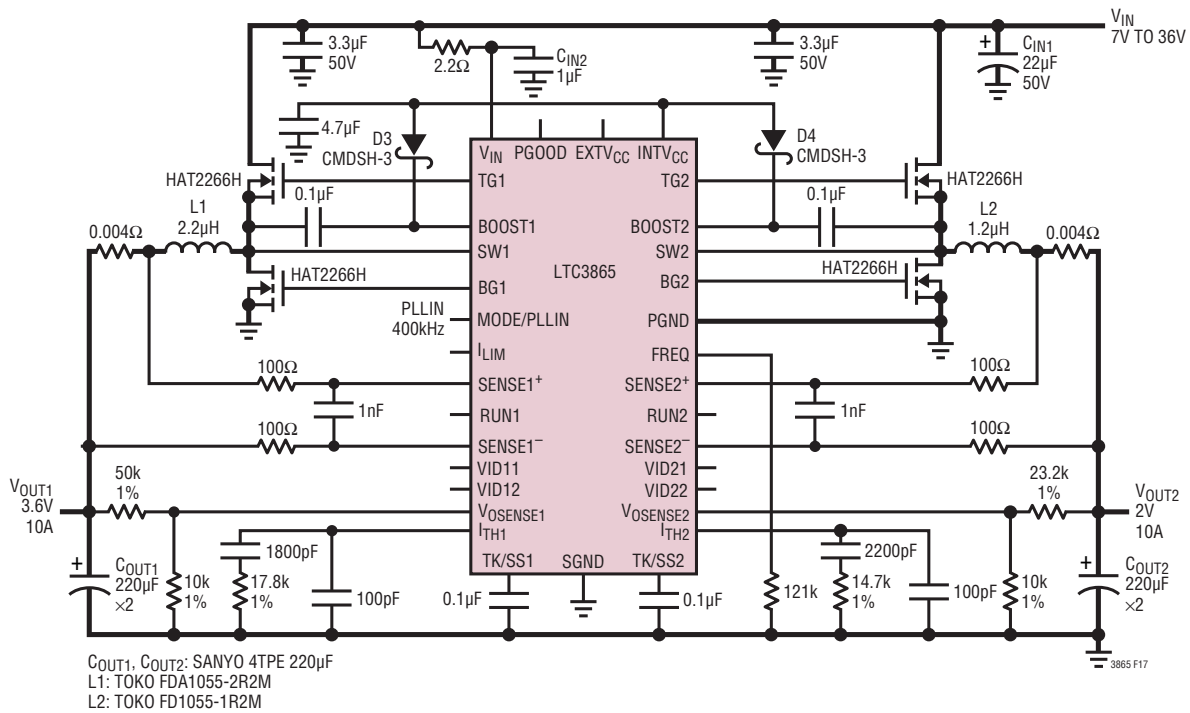

Figure 17. High  $V_{IN}$ , 3.6V/10A, 2V/10A Converter With External Sense Resistors Synchronized at 400kHz

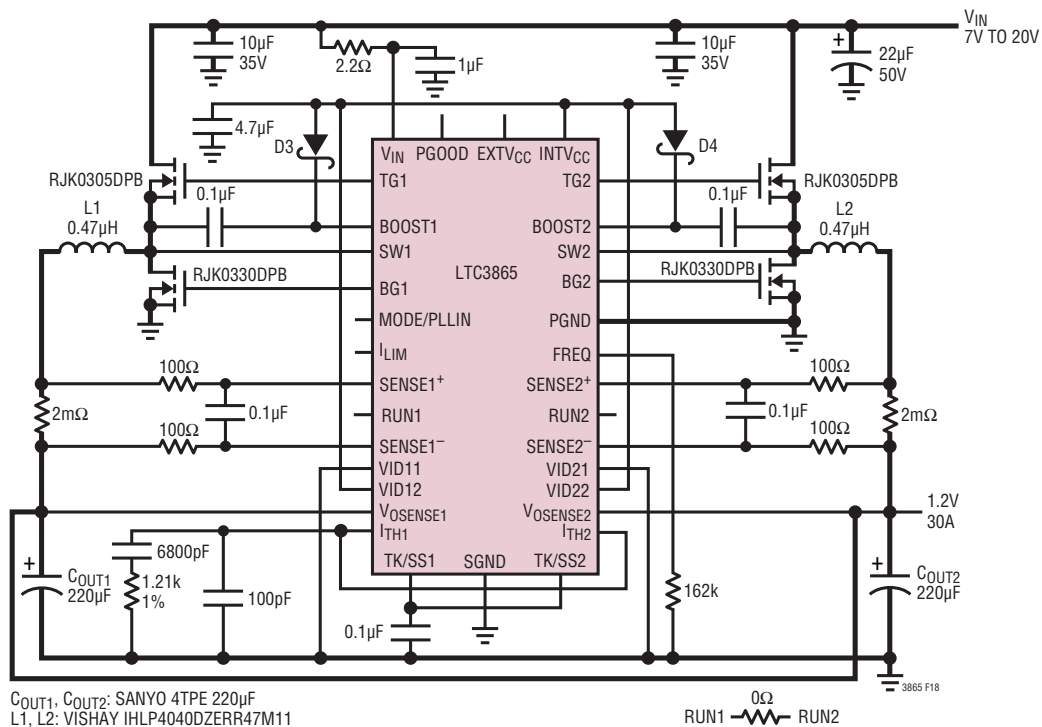
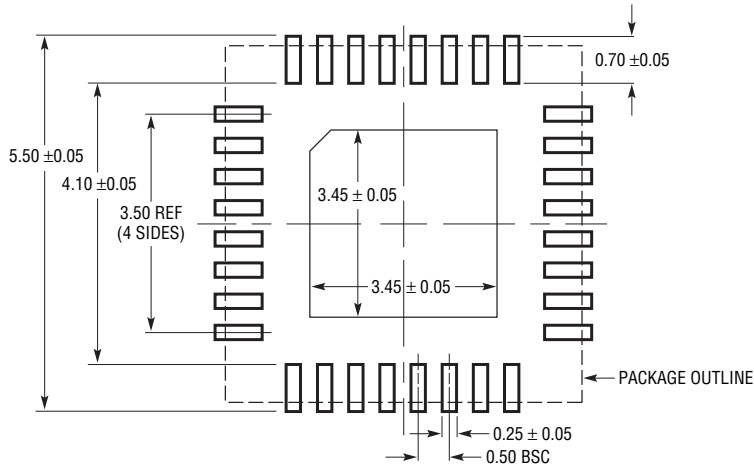

Figure 18. High Current, Single Output, 1.2V/30A Converter Using Sense Resistors

## PACKAGE DESCRIPTION

**UH Package**  
**32-Lead Plastic QFN (5mm × 5mm)**  
 (Reference LTC DWG # 05-08-1693 Rev D)



RECOMMENDED SOLDER PAD LAYOUT  
 APPLY SOLDER MASK TO AREAS THAT ARE NOT SOLDERED

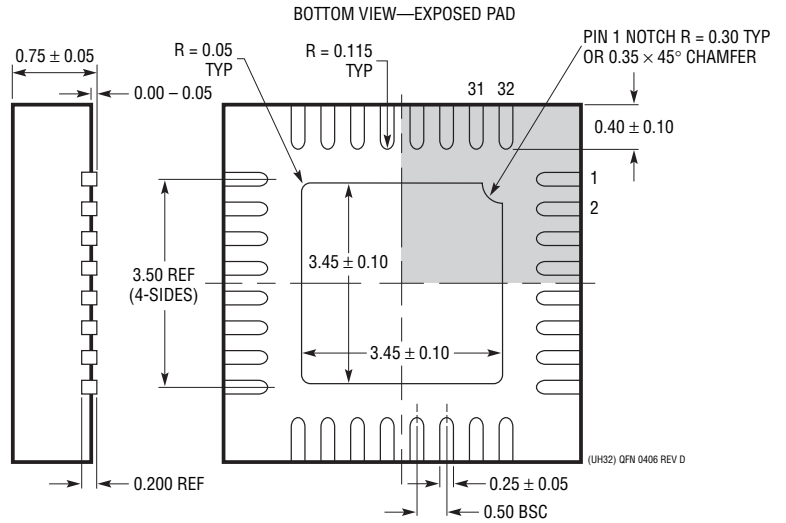
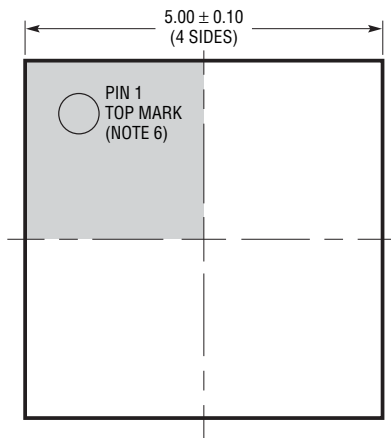

- NOTE:
1. DRAWING PROPOSED TO BE A JEDEC PACKAGE OUTLINE MO-220 VARIATION WHHD-(X) (TO BE APPROVED)
  2. DRAWING NOT TO SCALE
  3. ALL DIMENSIONS ARE IN MILLIMETERS
  4. DIMENSIONS OF EXPOSED PAD ON BOTTOM OF PACKAGE DO NOT INCLUDE MOLD FLASH. MOLD FLASH, IF PRESENT, SHALL NOT EXCEED 0.20mm ON ANY SIDE
  5. EXPOSED PAD SHALL BE SOLDER PLATED
  6. SHADED AREA IS ONLY A REFERENCE FOR PIN 1 LOCATION ON THE TOP AND BOTTOM OF PACKAGE

# PACKAGE DESCRIPTION

**FE Package**  
**38-Lead Plastic TSSOP (4.4mm)**  
 (Reference LTC DWG # 05-08-1772 Rev A)  
**Exposed Pad Variation AA**

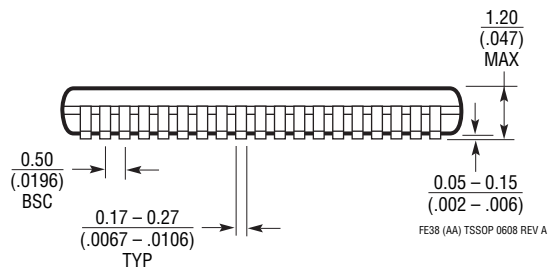
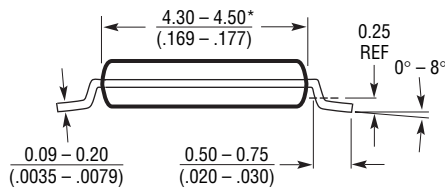
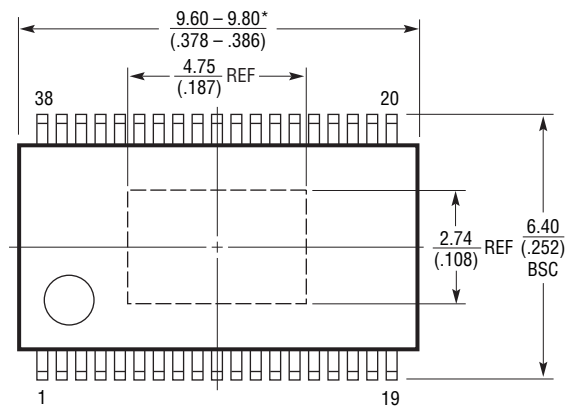
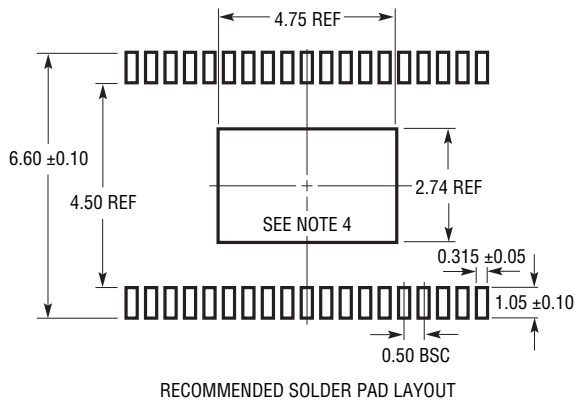

**NOTE:**

1. CONTROLLING DIMENSION: MILLIMETERS
2. DIMENSIONS ARE IN MILLIMETERS (INCHES)
3. DRAWING NOT TO SCALE

4. RECOMMENDED MINIMUM PCB METAL SIZE FOR EXPOSED PAD ATTACHMENT

\*DIMENSIONS DO NOT INCLUDE MOLD FLASH. MOLD FLASH SHALL NOT EXCEED 0.150mm (.006") PER SIDE

# LTC3865/LTC3865-1

## RELATED PARTS

PART NUMBER	DESCRIPTION	COMMENTS
LTC3850/LTC3850-1 LTC3850-2	Dual 2-Phase, High Efficiency Synchronous Step-Down DC/DC Controllers, R <sub>SENSE</sub> or DCR Current Sensing and Tracking	Phase-Lockable Fixed Operating Frequency 250kHz to 780kHz, 4V ≤ V <sub>IN</sub> ≤ 30V, 0.8V ≤ V <sub>OUT</sub> ≤ 5.25V
LTC3855	Dual, Multiphase Synchronous Step-Down DC/DC Controller with Diffamp and DCR Temperature Compensation	Phase-Lockable Fixed Operating Frequency 250kHz to 770kHz, 4.5V ≤ V <sub>IN</sub> ≤ 38V, 0.8V ≤ V <sub>OUT</sub> ≤ 12.5V
LTM <sup>®</sup> 4619	Dual, 4A DC/DC μModule <sup>®</sup> Complete Power Supply	High Efficiency, Compact Size, Fast Transient Response 4.5V ≤ V <sub>IN</sub> ≤ 26.5V, 0.8V ≤ V <sub>OUT</sub> ≤ 5V, 15mm × 15mm × 2.8mm LGA
LTC3868/LTC3868-1	Low I <sub>Q</sub> , Dual Output 2-Phase Synchronous Step-Down DC/DC Controller with 99% Duty Cycle	Phase-Lockable Fixed Operating Frequency 50kHz to 900kHz, 4V ≤ V <sub>IN</sub> ≤ 24V, 0.8V ≤ V <sub>OUT</sub> ≤ 14V, I <sub>Q</sub> = 170μA,
LTC3857/LTC3857-1	Low I <sub>Q</sub> , Dual, 2-Phase Synchronous Step-Down Controllers	50μA I <sub>Q</sub> , 0.8V ≤ V <sub>OUT</sub> ≤ 24V, 4V ≤ V <sub>IN</sub> ≤ 38V, Output Overcurrent Foldback Protection
LTC3858/LTC3858-1	Low I <sub>Q</sub> , Dual, 2-Phase Synchronous Step-Down Controllers	170μA I <sub>Q</sub> , 0.8V ≤ V <sub>OUT</sub> ≤ 24V, 4V ≤ V <sub>IN</sub> ≤ 38V, Output Overcurrent Latchoff Protection
LTC3853	Triple Output, Multiphase Synchronous Step-Down DC/DC Controller, R <sub>SENSE</sub> or DCR Current Sensing and Tracking	Phase-Lockable Fixed Operating Frequency 250kHz to 750kHz, 4V ≤ V <sub>IN</sub> ≤ 24V, V <sub>OUT</sub> Up to 13.5V
LTC3854	Small Footprint Wide V <sub>IN</sub> Range Synchronous Step-Down DC/DC Controller	Fixed 400kHz Operating Frequency 4.5V ≤ V <sub>IN</sub> ≤ 38V, 0.8V ≤ V <sub>OUT</sub> ≤ 5.25V, 2mm × 3mm QFN-12
LTC3851A LTC3851A-1	No R <sub>SENSE</sub> <sup>™</sup> Wide V <sub>IN</sub> Range Synchronous Step-Down DC/DC Controller	Phase-Lockable Fixed Operating Frequency 250kHz to 750kHz, 4V ≤ V <sub>IN</sub> ≤ 38V, 0.8V ≤ V <sub>OUT</sub> ≤ 5.25V, MSOP-16E, 3mm × 3mm QFN-16, SSOP-16
LTC3775	High Frequency, Synchronous Voltage Mode Step-Down DC/DC Controller	Synchronizable Fixed Frequency 250kHz to 1MHz, t <sub>ON(MIN)</sub> = 30ns, 4V ≤ V <sub>IN</sub> ≤ 38V, 0.6V ≤ V <sub>OUT</sub> ≤ 0.8V, MSOP-16E, 3mm × 3mm QFN-16
LTC3878	No R <sub>SENSE</sub> Constant On-Time Synchronous Step-Down DC/DC Controller	Very Fast Transient Response, t <sub>ON(MIN)</sub> = 43ns, 4V ≤ V <sub>IN</sub> ≤ 38V, 0.8V ≤ V <sub>OUT</sub> ≤ 0.9V <sub>IN</sub> , SSOP-16
LTC3879	No R <sub>SENSE</sub> Constant On-Time Synchronous Step-Down DC/DC Controller	Very Fast Transient Response, t <sub>ON(MIN)</sub> = 43ns, 4V ≤ V <sub>IN</sub> ≤ 38V, 0.6V ≤ V <sub>OUT</sub> ≤ 0.9V <sub>IN</sub> , MSOP-16E, 3mm × 3mm QFN-16
LTM4600HV	10A DC/DC μModule Regulator	High Efficiency, Compact Size, Fast Transient Response 4.5V ≤ V <sub>IN</sub> ≤ 28V, 0.8V ≤ V <sub>OUT</sub> ≤ 5V, 15mm × 15mm × 2.8mm LGA
LTM4601AHV	12A DC/DC μModule Regulator	High Efficiency, Compact Size, Fast Transient Response 4.5V ≤ V <sub>IN</sub> ≤ 28V, 0.8V ≤ V <sub>OUT</sub> ≤ 5V, 15mm × 15mm × 2.8mm LGA
LTC3610	12A, 1MHz, Monolithic Synchronous Step-Down DC/DC Converter	High Efficiency, Adjustable Constant On-Time 4V ≤ V <sub>IN</sub> ≤ 24V, V <sub>OUT(MIN)</sub> 0.6V, 9mm × 9mm QFN-64
LTC3611	10A, 1MHz, Monolithic Synchronous Step-Down DC/DC Converter	High Efficiency, Adjustable Constant On-Time 4V ≤ V <sub>IN</sub> ≤ 32V, V <sub>OUT(MIN)</sub> 0.6V, 9mm × 9mm QFN-64