

# 400mA/800mA Synchronous Step-Down DC/DC with Average Input Current Limit

## FEATURES

- **Programmable Average Input Current Limit:  $\pm 5\%$  Accuracy**
- **Dual Step-Down Outputs: Up to 96% Efficiency**
- **Low Noise Pulse-Skipping Operation at Light Loads**
- **Input Voltage Range: 2.5V to 5.5V**
- **Output Voltage Range: 0.6V to 5V**
- **2.25MHz Constant-Frequency Operation**
- **Power Good Output Voltage Monitor for Each Channel**
- **Low Dropout Operation: 100% Duty Cycle**
- **Independent Internal Soft-Start for Each Channel**
- **Current Mode Operation for Excellent Line and Load Transient Response**
- **$\pm 2\%$  Output Voltage Accuracy**
- **Short-Circuit Protected**
- **Shutdown Current  $\leq 1\mu\text{A}$**
- **Available in Small Thermally Enhanced 10-Lead MS and  $3\text{mm} \times 3\text{mm}$  DFN Packages**

## APPLICATIONS

- High Peak Load Current Applications
- USB Powered Devices
- Supercapacitor Charging
- Radio Transmitters and Other Handheld Devices

LT, LT, LTC, LTM, Linear Technology, the Linear logo and Burst Mode are registered trademarks and Hot Swap is a trademark of Linear Technology Corporation. All other trademarks are the property of their respective owners. Protected by U.S. Patents, including 5481178, 6127815, 6304066, 6498466, 6580258, 6611131.

## DESCRIPTION

The LTC<sup>®</sup>3619B is a dual monolithic synchronous buck regulator using a constant frequency current mode architecture.

The input supply voltage range is 2.5V to 5.5V, making it ideal for Li-Ion and USB powered applications. 100% duty cycle capability provides low dropout operation, extending the run time in battery-operated systems. Low output voltages are supported with the 0.6V feedback reference voltage. Channel 1 and channel 2 can supply 400mA and 800mA output current, respectively.

The LTC3619B's programmable average input current limit is ideal for USB applications and for point-of-load power supplies because the LTC3619B's limited input current will still allow its output to deliver high peak load currents without collapsing the input supply. When the sum of both channels' currents exceeds the input current limit, channel 2 is current limited while channel 1 remains regulated. The operating frequency is internally set at 2.25MHz allowing the use of small surface mount inductors. Internal soft-start reduces in-rush current during start-up. The LTC3619B is available in small MSOP and  $3\text{mm} \times 3\text{mm}$  DFN packages. The LTC3619B is also available in a low quiescent current, high efficiency Burst Mode<sup>®</sup> version, LTC3619.

## TYPICAL APPLICATION

Dual Monolithic Buck Regulator in 10-Lead  $3\text{mm} \times 3\text{mm}$  DFN

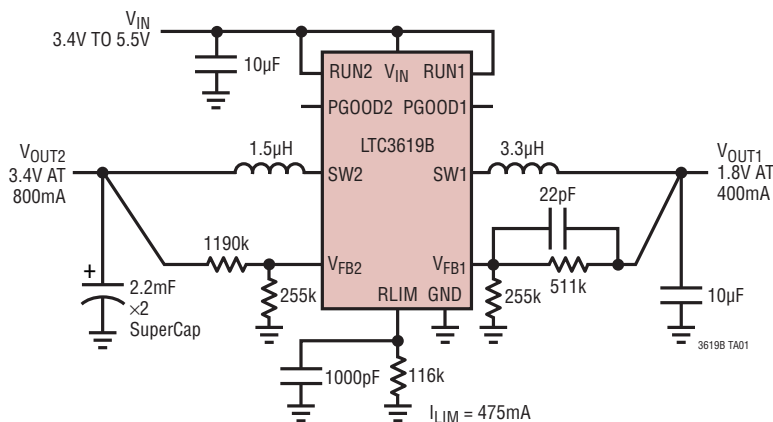

GSM Pulse Load

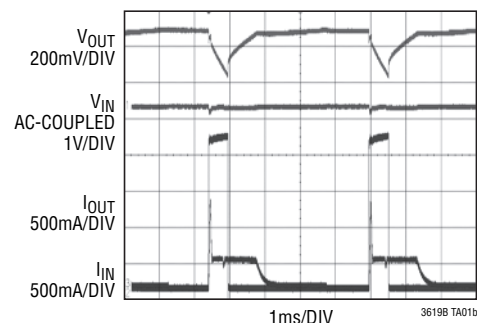

$V_{IN} = 5V$ , 500mA COMPLIANT  
 $I_{LOAD} = 0A$  to 2.2A, CHANNEL 1 UNLOADED

## ABSOLUTE MAXIMUM RATINGS (Note 1)

Input Supply Voltage ( $V_{IN}$ ).....	-0.3 to 6V	Peak SW Source and Sink Current (Note 2)	
$V_{FB1}$ , $V_{FB2}$ .....	-0.3V to $V_{IN} + 0.3V$	Channel 1.....	900mA
RUN1, RUN2, RLIM.....	-0.3V to $V_{IN} + 0.3V$	Channel 2.....	2.7A
SW1, SW2.....	-0.3V to $V_{IN} + 0.3V$	Operating Junction Temperature Range	
PGOOD1, PGOOD2.....	-0.3V to $V_{IN} + 0.3V$	(Notes 3, 6, 8).....	-40 to 125°C
P-channel SW Source Current (DC) (Note 2)		Storage Temperature Range .....	-65°C to 125°C
Channel 1.....	600mA	Lead Temperature (Soldering, 10 sec)	
Channel 2.....	1A	MSOP Package .....	300°C
N-channel SW Source Current (DC) (Note 2)		Reflow Peak Body Temperature .....	260°C
Channel 1.....	600mA		
Channel 2.....	1A		

## PIN CONFIGURATION

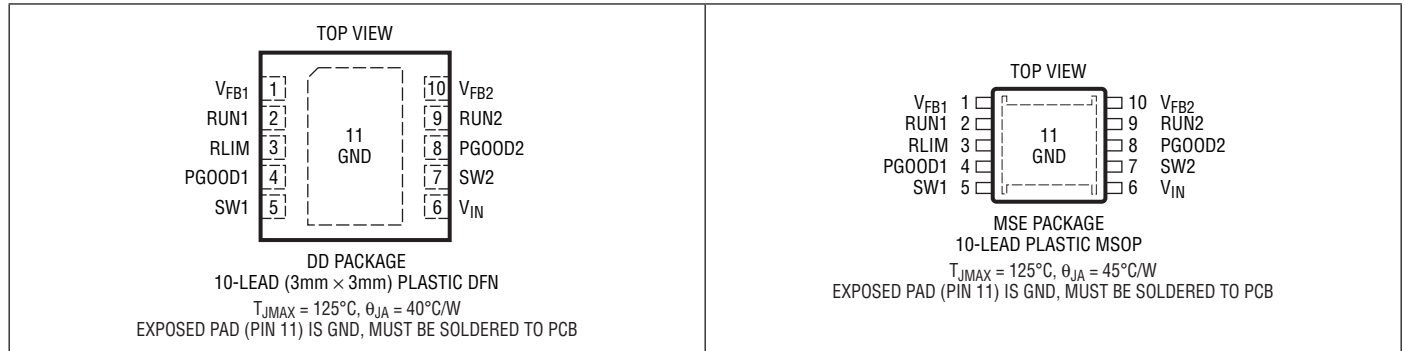

## ORDER INFORMATION

LEAD FREE FINISH	TAPE AND REEL	PART MARKING*	PACKAGE DESCRIPTION	TEMPERATURE RANGE
LTC3619BEDD#PBF	LTC3619BEDD#TRPBF	LFFH	10-Lead (3mm × 3mm) Plastic DFN	-40°C to 125°C
LTC3619BIDD#PBF	LTC3619BIDD#TRPBF	LFFH	10-Lead (3mm × 3mm) Plastic DFN	-40°C to 125°C
LTC3619BEMSE#PBF	LTC3619BEMSE#TRPBF	LTFJ	10-Lead Plastic MSOP	-40°C to 125°C
LTC3619BIMSE#PBF	LTC3619BIMSE#TRPBF	LTFJ	10-Lead Plastic MSOP	-40°C to 125°C

Consult LTC Marketing for parts specified with wider operating temperature ranges. \*The temperature grade is identified by a label on the shipping container. Consult LTC Marketing for information on non-standard lead based finish parts.

For more information on lead free part marking, go to: <http://www.linear.com/leadfree/>

For more information on tape and reel specifications, go to: <http://www.linear.com/tapeandree/>

## ELECTRICAL CHARACTERISTICS

The ● denotes the specifications which apply over the full operating junction temperature range, otherwise specifications are at  $T_A = 25^{\circ}C$  (Note 3)

SYMBOL	PARAMETER	CONDITIONS	MIN	TYP	MAX	UNITS
$V_{IN}$	$V_{IN}$ Operating Voltage Range		● 2.5		5.5	V
$V_{UV}$	$V_{IN}$ Undervoltage Lockout	$V_{IN}$ Low to High	●	2.1	2.5	V

## ELECTRICAL CHARACTERISTICS

The ● denotes the specifications which apply over the full operating junction temperature range, otherwise specifications are at  $T_A = 25^\circ\text{C}$  (Note 3)

SYMBOL	PARAMETER	CONDITIONS	MIN	TYP	MAX	UNITS	
$I_{FB}$	Feedback Pin Input Current		●		±30	nA	
$V_{FBREG}$	Feedback Voltage (Channels 1, 2)	LTC3619BE, $-40^\circ\text{C} < T_J < 85^\circ\text{C}$ (Note 7) LTC3619BI, $-40^\circ\text{C} < T_J < 125^\circ\text{C}$ (Note 7)	● ●	0.588 0.582	0.600 0.600	0.612 0.618	V V
$\Delta V_{LINEREG}$	$V_{FB}$ Line Regulation	$V_{IN} = 2.5\text{V}$ to $5.5\text{V}$ (Note 7)		0.01	0.25	%/V	
$\Delta V_{LOADREG}$	$V_{FB}$ Load Regulation (Channel 1) $V_{FB}$ Load Regulation (Channel 2)	$I_{LOAD} = 0\text{mA}$ to $400\text{mA}$ (Note 7) $I_{LOAD} = 0\text{mA}$ to $800\text{mA}$ (Note 7)		0.5 0.5		% %	
$I_S$	Supply Current Active Mode (Note 4) Shutdown	$V_{FB1} = V_{FB2} = 0.95 \times V_{FBREG}$ $V_{RUN1} = V_{RUN2} = 0\text{V}$ , $V_{IN} = 5.5\text{V}$		600	875 1	$\mu\text{A}$ $\mu\text{A}$	
$f_{OSC}$	Oscillator Frequency	$V_{FB} = V_{FBREG}$	●	1.8	2.25	2.7	MHz
$I_{LIM(PEAK)}$	Peak Switch Current Limit Channel 1 (400mA) Channel 2 (800mA)	$V_{IN} = 5\text{V}$ , $V_{FB} < V_{FBREG}$ , Duty Cycle <35%		550 1800	800 2400		mA mA
$I_{INLIM}$	Input Average Current Limit	$RLIM = 116\text{k}$ $RLIM = 116\text{k}$ , LTC3619BE $RLIM = 116\text{k}$ , LTC3619BI	● ●	450 437 427	475 475 475	500 513 523	mA mA mA
$R_{DS(ON)}$	Channel 1 (Note 5) Top Switch On-Resistance Bottom Switch On-Resistance Channel 2 (Note 5) Top Switch On-Resistance Bottom Switch On-Resistance	$V_{IN} = 5\text{V}$ , $I_{SW} = 100\text{mA}$ $V_{IN} = 5\text{V}$ , $I_{SW} = 100\text{mA}$ $V_{IN} = 5\text{V}$ , $I_{SW} = 100\text{mA}$ $V_{IN} = 5\text{V}$ , $I_{SW} = 100\text{mA}$			0.45 0.35 0.27 0.25		$\Omega$ $\Omega$ $\Omega$ $\Omega$
$I_{SW(LKG)}$	Switch Leakage Current	$V_{IN} = 5\text{V}$ , $V_{RUN} = 0\text{V}$		0.01	1		$\mu\text{A}$
$t_{SOFTSTART}$	Soft-Start Time	$V_{FB}$ from $0.06\text{V}$ to $0.54\text{V}$		0.3	0.95	1.3	ms
$V_{RUN}$	RUN Threshold High		●	0.4	1	1.2	V
$I_{RUN}$	RUN Leakage Current	$0\text{V} \leq V_{RUN} \leq 5\text{V}$	●		0.01	1	$\mu\text{A}$
PGOOD	Power Good Threshold	Entering Window $V_{FB}$ Ramping Up $V_{FB}$ Ramping Down Leaving Window $V_{FB}$ Ramping Up $V_{FB}$ Ramping Down		-5 5	-7 7		% % % %
PGOOD Blanking	Power Good Blanking Time	PGOOD Rising and Falling, $V_{IN} = 5\text{V}$			90		$\mu\text{s}$
$R_{PGOOD}$	Power Good Pull-Down On-Resistance			8	15	30	$\Omega$
$I_{PGOOD}$	PGOOD Leakage Current	$V_{PGOOD} = 5\text{V}$			±1		$\mu\text{A}$

**Note 1:** Stresses beyond those listed under Absolute Maximum Ratings may cause permanent damage to the device. Exposure to any Absolute Maximum Rating condition for extended periods may affect device reliability and lifetime.

**Note 2:** Guaranteed by long term current density limitations.

**Note 3:** The LTC3619B is tested under pulsed load conditions such that  $T_J \approx T_A$ . The LTC3619BE is guaranteed to meet performance specifications from  $0^\circ\text{C}$  to  $85^\circ\text{C}$ . Specifications over the  $-40^\circ\text{C}$  to  $125^\circ\text{C}$  operating junction temperature range are assured by design, characterization and correlation with statistical process controls. The LTC3619BI is guaranteed to meet specified performance over the full  $-40^\circ\text{C}$  to  $125^\circ\text{C}$  operating junction temperature range. Note that the maximum ambient temperature is determined by specific operating conditions in conjunction with board layout, the rated package thermal resistance and other environmental factors.

**Note 4:** Dynamic supply current is higher due to the internal gate charge being delivered at the switching frequency.

**Note 5:** The switch on-resistance is guaranteed by correlation to wafer level measurements.

**Note 6:** This IC includes overtemperature protection that is intended to protect the device during momentary overload conditions. Junction temperature will exceed  $125^\circ\text{C}$  when overtemperature protection is active. Continuous operation above the specified maximum operating junction temperature may impair device reliability.

**Note 7:** The converter is tested in a proprietary test mode that connects the output of the error amplifier to the SW pin, which is connected to an external servo loop.

**Note 8:**  $T_J$  is calculated from the ambient temperature  $T_A$  and the power dissipation as follows:  $T_J = T_A + (P_D)(\theta_{JA}^\circ\text{C/W})$

## TYPICAL PERFORMANCE CHARACTERISTICS $T_A = 25^\circ\text{C}$ , $V_{IN} = 5\text{V}$ , unless otherwise noted.

### Pulse-Skipping Mode Operation

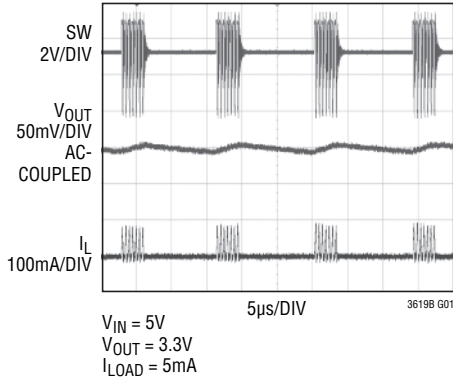

### Supply Current vs Temperature

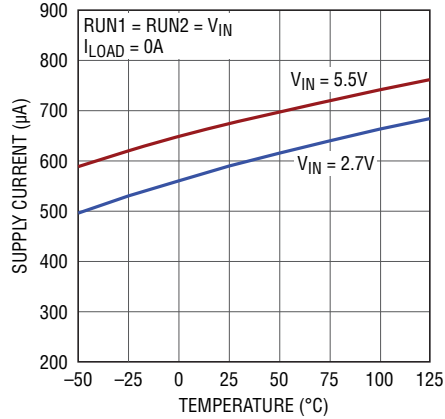

### Efficiency vs Input Voltage

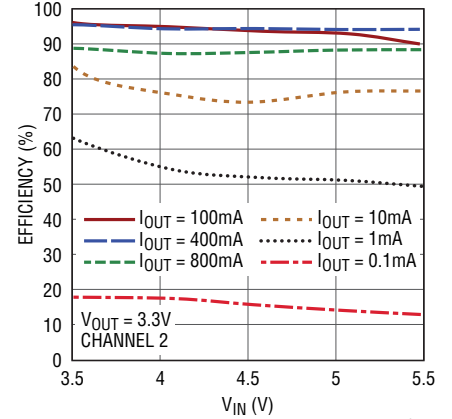

### Regulated Voltage vs Temperature

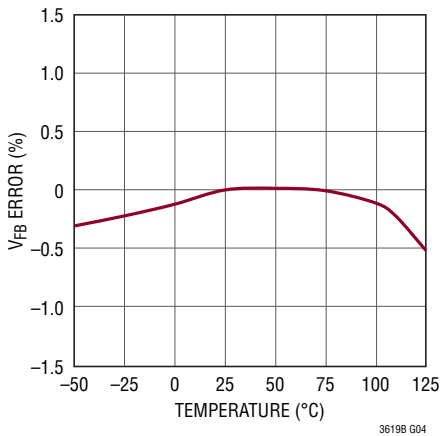

### Oscillator Frequency vs Temperature

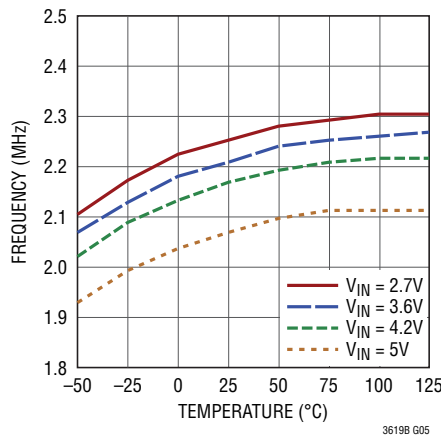

### Switch Leakage vs Input Voltage

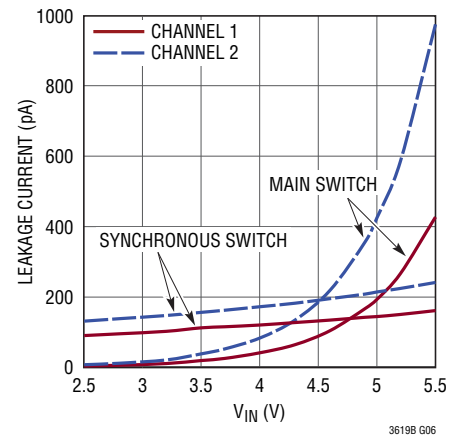

### Switch On-Resistance vs Input Voltage

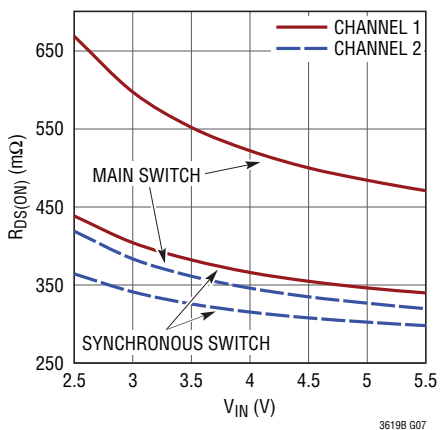

### Switch On-Resistance vs Temperature, Channel 1

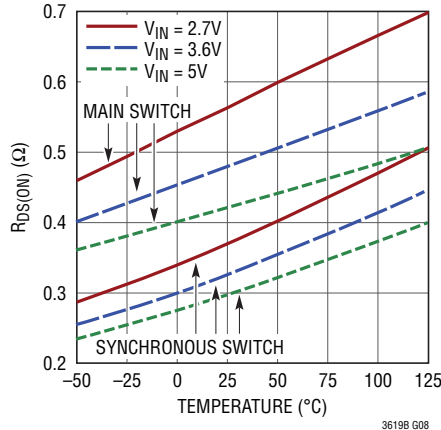

### Switch On-Resistance vs Temperature, Channel 2

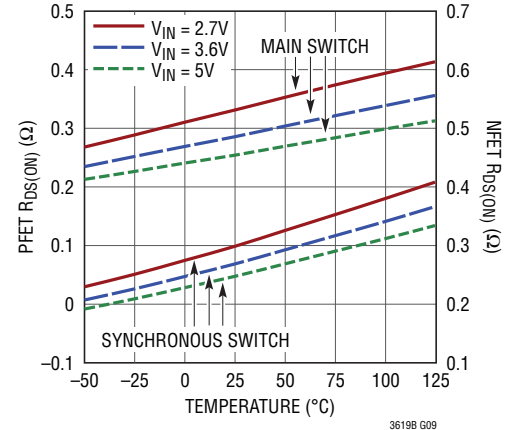

**TYPICAL PERFORMANCE CHARACTERISTICS**  $T_A = 25^\circ\text{C}$ ,  $V_{IN} = 5\text{V}$ , unless otherwise noted.

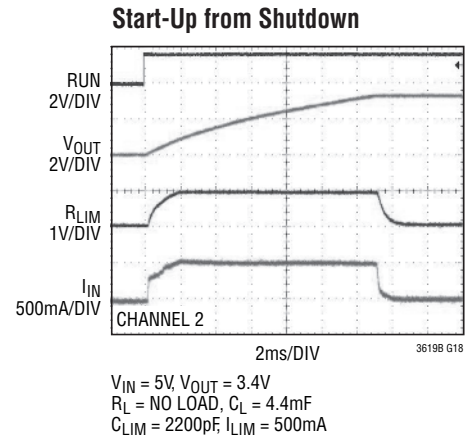
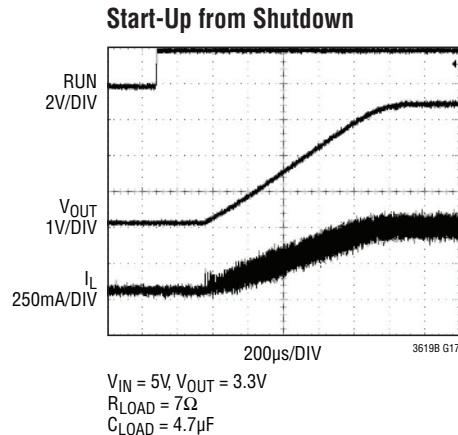
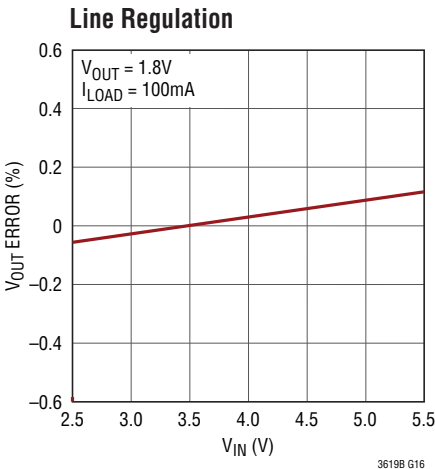
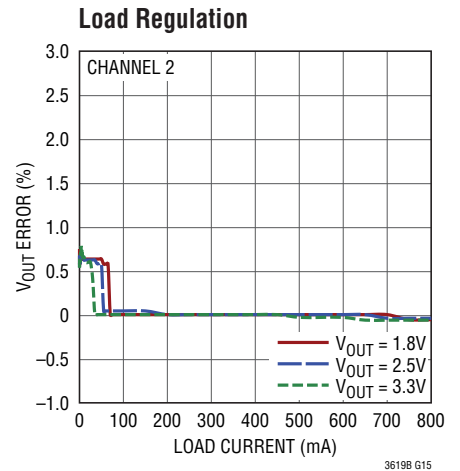
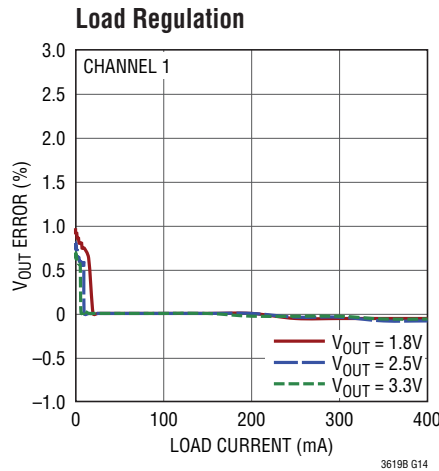
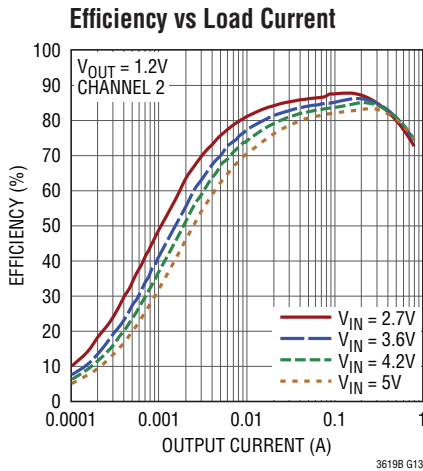
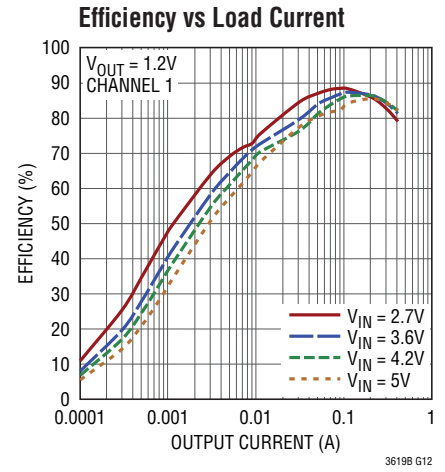
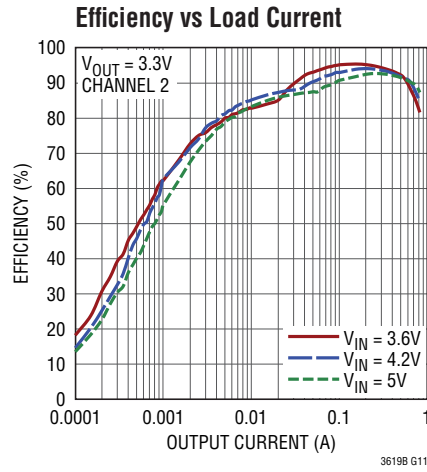
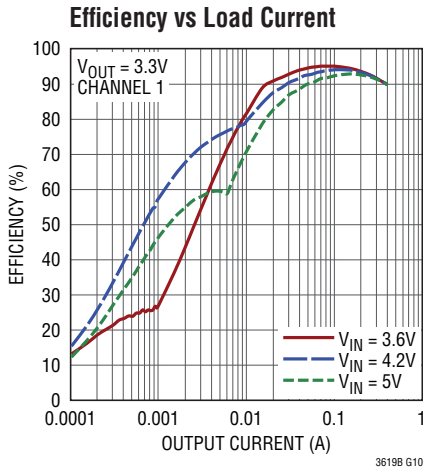

## TYPICAL PERFORMANCE CHARACTERISTICS $T_A = 25^\circ\text{C}$ , $V_{IN} = 5\text{V}$ , unless otherwise noted.

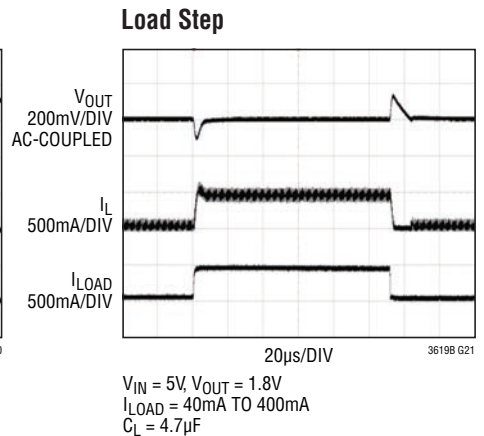
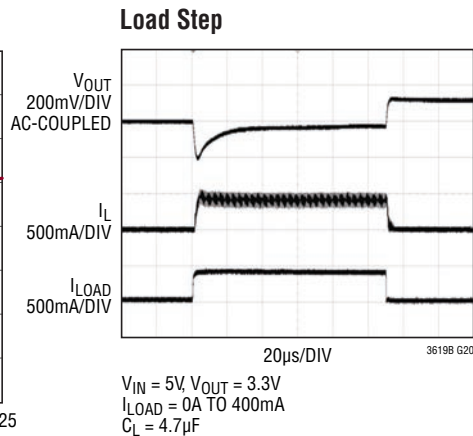
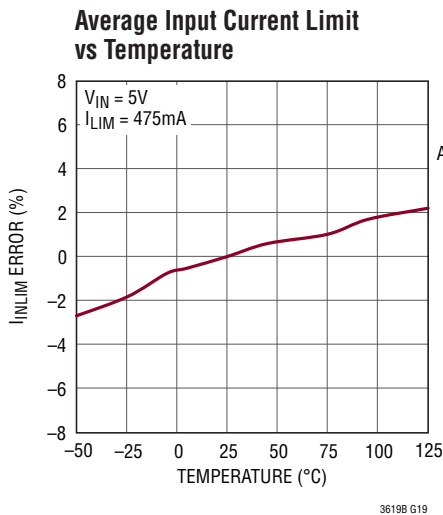

## PIN FUNCTIONS (DD/MSE)

**$V_{FB1}$  (Pin 1/Pin 1):** Regulator 1 Output Feedback. Receives the feedback voltage from the external resistive divider across the regulator 1 output. Nominal voltage for this pin is 0.6V.

**$RUN1$  (Pin 2/Pin 2):** Regulator 1 Enable. Forcing this pin to  $V_{IN}$  enables regulator 1, while forcing it to GND causes regulator 1 to shut down.

**$RLIM$  (Pin 3/Pin 3):** Average Input Current Limit Program Pin. Place a resistor and capacitor in parallel from this pin to ground.

**$PGOOD1$  (Pin 4/Pin 4):** Open-Drain Logic Output.  $PGOOD1$  is pulled to ground if the voltage on the  $V_{FB1}$  pin is not within power good threshold.

**$SW1$  (Pin 5/Pin 5):** Regulator 1 Switch Node Connection to the Inductor. This pin swings from  $V_{IN}$  to GND.

**$V_{IN}$  (Pin 6/Pin 6):** Main Power Supply. Must be closely de-coupled to GND.

**$SW2$  (Pin 7/Pin 7):** Regulator 2 Switch Node Connection to the Inductor. This pin swings from  $V_{IN}$  to GND.

**$PGOOD2$  (Pin 8/Pin 8):** Open-Drain Logic Output.  $PGOOD2$  is pulled to ground if the voltage on the  $V_{FB2}$  pin is not within power good threshold.

**$RUN2$  (Pin 9/Pin 9):** Regulator 2 Enable. Forcing this pin to  $V_{IN}$  enables regulator 2, while forcing it to GND causes regulator 2 to shut down.

**$V_{FB2}$  (Pin 10/Pin 10):** Regulator 2 Output Feedback. Receives the feedback voltage from the external resistive divider across the regulator 2 output. Nominal voltage for this pin is 0.6V.

**GND (Pin 11/Pin 11):** Ground. Bottom Exposed Pad. Connect to the (-) terminal of  $C_{OUT}$ , and the (-) terminal of  $C_{IN}$ . The Exposed Pad must be soldered to PCB.

FUNCTIONAL DIAGRAM

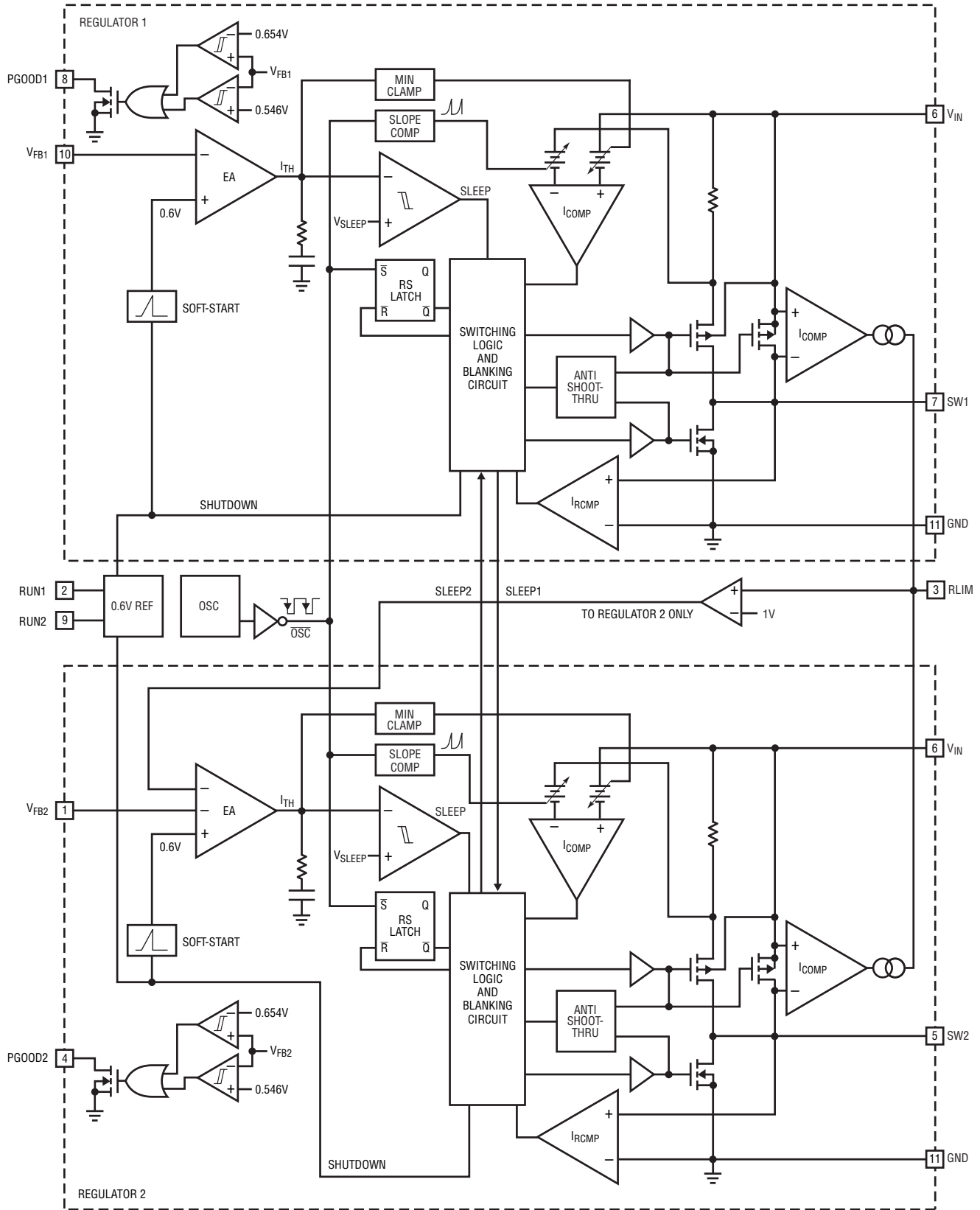

3619B FD



## OPERATION

The LTC3619B uses a constant-frequency, current mode architecture. The operating frequency is set at 2.25MHz. Both channels share the same clock and run in-phase.

The output voltage is set by an external resistor divider returned to the  $V_{FB}$  pins. An error amplifier compares the divided output voltage with a reference voltage of 0.6V and regulates the peak inductor current accordingly.

The LTC3619B continuously monitors the input current of both channels. When the sum of the currents of both channels exceeds the programmed input current limit set by an external resistor,  $R_{LIM}$ , channel 2 is current limited while channel 1 remains regulated.

### Main Control Loop

During normal operation, the top power switch (P-channel MOSFET) is turned on at the beginning of a clock cycle when the  $V_{FB}$  voltage is below the reference voltage. The current into the inductor and the load increases until the peak inductor current (controlled by  $I_{TH}$ ) is reached. The RS latch turns off the synchronous switch and energy stored in the inductor is discharged through the bottom switch (N-channel MOSFET) into the load until the next clock cycle begins, or until the inductor current begins to reverse (sensed by the  $I_{RCMP}$  comparator).

The peak inductor current is controlled by the internally compensated  $I_{TH}$  voltage, which is the output of the error amplifier. This amplifier regulates the  $V_{FB}$  pin to the internal 0.6V reference by adjusting the peak inductor current accordingly.

When the input current limit is engaged, the peak inductor current will be lowered, which then reduces the switching duty cycle and  $V_{OUT}$ . This allows the input voltage to stay regulated when its programmed current output capability is met.

### Light Load Operation

The LTC3619B will automatically transition from continuous operation to the pulse-skipping operation when the load current is low. The inductor current is not fixed during the pulse-skipping mode which allows the LTC3619B to switch at constant-frequency down to very low currents, where it

will begin skipping pulses to maintain output regulation. This mode of operation exhibits low output ripple as well as low audio noise and reduced RF interference while providing reasonable low current efficiency.

### Dropout Operation

When the input supply voltage decreases toward the output voltage the duty cycle increases to 100%, which is the dropout condition. In dropout, the PMOS switch is turned on continuously with the output voltage being equal to the input voltage minus the voltage drops across the internal P-channel MOSFET and the inductor.

An important design consideration is that the  $R_{DS(ON)}$  of the P-channel switch increases with decreasing input supply voltage (see the Typical Performance Characteristics section). Therefore, the user should calculate the worst-case power dissipation when the LTC3619B is used at 100% duty cycle with low input voltage (see Thermal Considerations in the Applications Information section).

### Soft-Start

In order to minimize the inrush current on the input bypass capacitor, the LTC3619B slowly ramps up the output voltage during start-up. Whenever the RUN1 or RUN2 pin is pulled high, the corresponding output will ramp from zero to full-scale over a time period of approximately 750 $\mu$ s. This prevents the LTC3619B from having to quickly charge the output capacitor and thus supplying an excessive amount of instantaneous current.

When the output is loaded heavily, for example, with millifarad of capacitance, it may take longer than 750 $\mu$ s to charge the output to regulation. If the output is still low after the soft-start time, the LTC3619B will try to quickly charge the output capacitor. In this case, the input current limit (after it engages) can prevent excessive amount of instantaneous current that is required to quickly charge the output. See the Channel 2 Start-Up from Shutdown curve in the Typical Performance Characteristics section. After input current limit is engaged, the output slowly ramps up to regulation while limited by its 500mA of input current.



## OPERATION

### Short-Circuit Protection

When either regulator output is shorted to ground, the corresponding internal N-channel switch is forced on for a longer time period for each cycle in order to allow the inductor to discharge, thus preventing inductor current runaway. This technique has the effect of decreasing switching frequency. Once the short is removed, normal operation resumes and the regulator output will return to its nominal voltage.

### Input Current Limit

Internal current sense circuitry in each channel measures the inductor current through the voltage drop across the power PFET switch and forces the same voltage across the small sense PFET. The voltage across the small sense PFET generates a current representing 1/55,000th of the inductor current during the on-cycle. The current out of RLIM pin is the summed representation of the inductor currents from both channels, which can be expressed in the following equation.

$$I_{RLIM} = I_{OUT1} \cdot D1 \cdot K1 + I_{OUT2} \cdot D2 \cdot K2,$$

where  $D1 = V_{OUT1}/V_{IN}$  and  $D2 = V_{OUT2}/V_{IN}$  are the duty cycle of channel 1 and 2, respectively.

$K1$  is the ratio  $R_{DS(ON)}$  (power PFET)/ $R_{DS(ON)}$  (sense PFET) of channel 1, and  $K2$  is the ratio  $R_{DS(ON)}$  (power PFET)/ $R_{DS(ON)}$  (sense PFET) of channel 2. The ratio of the power PFET to the sense PFET is trimmed to within 2%.

Given that both PFETs are carefully laid out and matched, their temperature and voltage coefficient effects will be similar and their terms be canceled out in the equation. In that case, the constants  $K1$  and  $K2$  will only be dependent on area scaling, which is trimmed to within 2%. Thus, the  $I_{RLIM}$  current will track the input current very well over varying temperature and  $V_{IN}$ .

The RLIM pin can be grounded to disable input current limit function.

### Programming Input Current Limit

Selection of one external  $R_{LIM}$  resistor will program the input current limit. The current limit can be programmed from 200mA up to  $I_{PEAK}$  current. As the input current increases,  $R_{LIM}$  voltage will follow. When  $R_{LIM}$  reaches the internal comparator threshold of 1V, channel 2's power PFET on-time will be shortened, thereby, limiting the input current.

Use the following equation to select the  $R_{LIM}$  resistance that corresponds to the input current limit.

$$R_{LIM} = \frac{55k\Omega - A}{I_{DC}(A)}$$

$I_{DC}$  is the input current (at  $V_{IN}$ ) to be limited. The following are some  $R_{LIM}$  values with the corresponding current limit.

$R_{LIM}$	$I_{DC}$
91.6k	600mA
110k	500mA
137.5k	400mA

### Selection of $C_{LIM}$ Capacitance

Since  $I_{RLIM}$  current is a function of the inductor current, its dependency on the duty cycle cannot be ignored. Thus, a  $C_{LIM}$  capacitor is needed to integrate the  $I_{RLIM}$  current and smooth out transient currents. The LTC3619B is stable with any size capacitance  $>100\text{pF}$  at the RLIM pin.

Each application input current limit will call for different  $C_{LIM}$  value to optimize its response time. Using a large  $C_{LIM}$  capacitor requires longer time for the RLIM pin voltage to charge. For example, consider the application 500mA input current limit, 5V input and 1A, 2.5V output with a 50% duty cycle. When an instantaneous 1A output pulse is applied, the current out of the RLIM pin becomes  $1A/55k = 18.2\mu\text{A}$  during the 50% on-time or  $9.1\mu\text{A}$  full duty cycle. With a  $C_{LIM}$  capacitor of  $1\mu\text{F}$ ,  $R_{LIM}$  of 116k, and using  $I = Cdv/dt$ , it will take 110ms for  $C_{LIM}$  to charge from 0V to 1V. This is the time after which the LTC3619B will start input current

## OPERATION

limiting. Any current within this time must be considered in each application to determine if it is tolerable.

Figure 1a shows  $V_{IN}$  ( $I_{IN}$ ) current below input current limit with a  $C_{LIM}$  capacitor of  $0.1\mu F$ . Channel 1 is unloaded to simplify calculations. When the load pulse is applied, under the specified condition,  $I_{LIM}$  current is  $1.1A/55k \cdot 0.66 = 13.2\mu A$ , where 0.66 is the duty cycle. It will take a little more than 7.5ms to charge the  $C_{LIM}$  capacitor from 0V to 1V, after which the LTC3619B begins to limit input current. The  $I_{IN}$  current is not limited during this 7.5ms time and is more than 725mA. This current transient may cause the input supply to temporarily droop if the supply current compliance is exceeded, but recovers after the input current limit engages. The output will continue to deliver the required current load while the output voltage droops to allow the input voltage to remain regulated during input current limit.

For applications with short load pulse duration, a smaller  $C_{LIM}$  capacitor may be the better choice as in the example shown in Figure 1b. Channel 1 is unloaded for simplification. In this example, a  $577\mu s$ , 0A to 2A output pulse

is applied once every 4.7ms. A  $C_{LIM}$  capacitor of  $2.2nF$  requires  $92\mu s$  for  $V_{RLIM}$  to charge from 0V to 1V. During this  $92\mu s$ , the input current limit is not yet engaged and the output must deliver the required current load. This may cause the input voltage to droop if the current compliance is exceeded. Depending on how long this time is, the  $V_{IN}$  supply decoupling capacitor can provide some of this current before  $V_{IN}$  droops too much. In applications with a bigger  $V_{IN}$  supply decoupling capacitor and where  $V_{IN}$  supply is allow to droop closer to dropout, the  $C_{LIM}$  capacitor can be increased slightly. This will delay the start of input current limit and artificially regulated  $V_{OUT}$  before input current limit is engaged. In this case, within the  $577\mu s$  load pulse, the  $V_{OUT}$  voltage will stay artificially regulated for  $92\mu s$  out of the total  $577\mu s$  before the input current limit activates. This approach may be used if a faster recovery on the output is desired.

Selecting a very small  $C_{LIM}$  will speed up response time but it can put the device within threshold of interfering with normal operation and input current limit in every few switching cycles. This may be undesirable in terms of noise. Use  $2\pi RC \gg 100/\text{clock frequency}$  ( $2.25\text{MHz}$ ) as

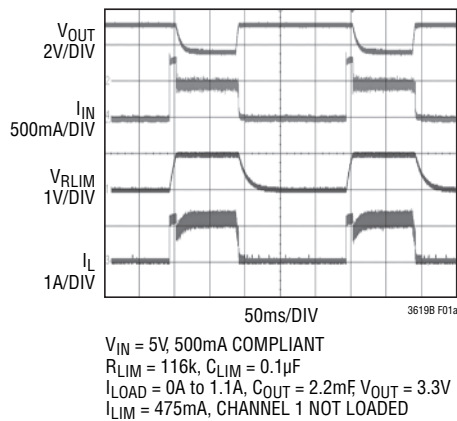

Figure 1a. Input Current Limit Within 100ms Load Pulses

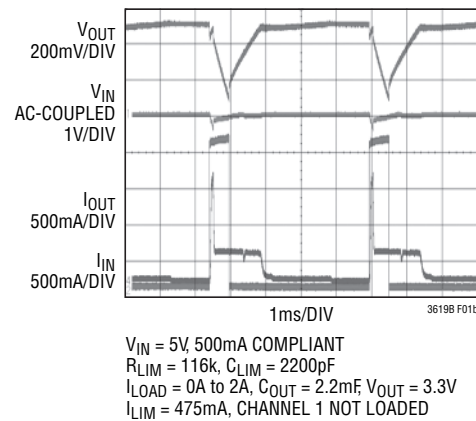

Figure 1b. Input Current Limit Within  $577\mu s$ , 2A Repeating Load Pulses

## APPLICATIONS INFORMATION

A general LTC3619B application circuit is shown in Figure 2. External component selection is driven by the load requirement, and begins with the selection of the inductor L. Once the inductor is chosen, C<sub>IN</sub> and C<sub>OUT</sub> can be selected.

### Inductor Selection

Although the inductor does not influence the operating frequency, the inductor value has a direct effect on ripple current. The inductor ripple current  $\Delta I_L$  decreases with higher inductance and increases with higher V<sub>IN</sub> or V<sub>OUT</sub>:

$$\Delta I_L = \frac{V_{OUT}}{f_0 \cdot L} \cdot \left(1 - \frac{V_{OUT}}{V_{IN}}\right) \quad (1)$$

Accepting larger values of  $\Delta I_L$  allows the use of low inductances, but results in higher output voltage ripple, greater core losses, and lower output current capability. A reasonable starting point for setting ripple current is 40% of the maximum output load current. So, for a 800mA regulator,  $\Delta I_L = 320\text{mA}$  (40% of 800mA).

The inductor value will also have an effect on Burst Mode operation. The transition to low current operation begins when the peak inductor current falls below a level set by the internal burst clamp. Lower inductor values result in higher ripple current which causes the transition to occur at lower load currents. This causes a dip in efficiency in the upper range of low current operation. Furthermore, lower inductance values will cause the bursts to occur with increased frequency.

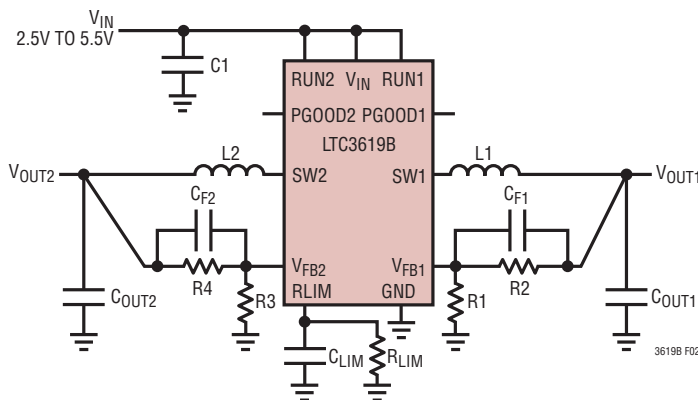

Figure 2. LTC3619B General Schematic

### Inductor Core Selection

Different core materials and shapes will change the size/current and price/current relationship of an inductor. Toroid or shielded pot cores in ferrite or permalloy materials are small and do not radiate much energy, but generally cost more than powdered iron core inductors with similar electrical characteristics. The choice of which style inductor to use often depends more on the price versus size requirements, and any radiated field/EMI requirements, than on what the LTC3619B requires to operate. Table 1 shows some typical surface mount inductors that work well in LTC3619B applications.

Table 1. Representative Surface Mount Inductors

MANUFACTURER	PART NUMBER	VALUE	MAX DC CURRENT	DCR	HEIGHT
Coilcraft	LPS4012-152ML	1.5 $\mu\text{H}$	2200mA	0.070 $\Omega$	1.2mm
	LPS4012-222ML	2.2 $\mu\text{H}$	1750mA	0.100 $\Omega$	1.2mm
	LPS4012-332ML	3.3 $\mu\text{H}$	1450mA	0.100 $\Omega$	1.2mm
	LPS4012-472ML	4.7 $\mu\text{H}$	1450mA	0.170 $\Omega$	1.2mm
	LPS4018-222ML	2.2 $\mu\text{H}$	2300mA	0.070 $\Omega$	1.8mm
	LPS4018-332ML	3.3 $\mu\text{H}$	2000mA	0.080 $\Omega$	1.8mm
	LPS4018-472ML	4.7 $\mu\text{H}$	1800mA	0.125 $\Omega$	1.8mm
FDK	FDKMIPF2520D	4.7 $\mu\text{H}$	1100mA	0.11 $\Omega$	1mm
	FDKMIPF2520D	3.3 $\mu\text{H}$	1200mA	0.1 $\Omega$	1mm
	FDKMIPF2520D	2.2 $\mu\text{H}$	1300mA	0.08 $\Omega$	1mm
Murata	LQH32CN4R7M23	4.7 $\mu\text{H}$	450mA	0.2 $\Omega$	2mm
Panasonic	ELT5KT4R7M	4.7 $\mu\text{H}$	950mA	0.2 $\Omega$	1.2mm
Sumida	CDRH2D18/LD	4.7 $\mu\text{H}$	630mA	0.086 $\Omega$	2mm
	CDH38D11SNP-3R3M	3.3 $\mu\text{H}$	1560mA	0.115 $\Omega$	1.2mm
	CDH38D11SNP-2R2M	2.2 $\mu\text{H}$	1900mA	0.082 $\Omega$	1.2mm
Taiyo Yuden	CB2016T2R2M	2.2 $\mu\text{H}$	510mA	0.13 $\Omega$	1.6mm
	CB2012T2R2M	2.2 $\mu\text{H}$	530mA	0.33 $\Omega$	1.25mm
	CB2016T3R3M	3.3 $\mu\text{H}$	410mA	0.27 $\Omega$	1.6mm
	NR30102R2M	2.2 $\mu\text{H}$	1100mA	0.1 $\Omega$	1mm
	NR30104R7M	4.7 $\mu\text{H}$	750mA	0.19 $\Omega$	1mm
TDK	VLF3010AT4R7-MR70	4.7 $\mu\text{H}$	700mA	0.28 $\Omega$	1mm
	VLF3010AT3R3-MR87	3.3 $\mu\text{H}$	870mA	0.17 $\Omega$	1mm
	VLF3010AT2R2-M1R0	2.2 $\mu\text{H}$	1000mA	0.12 $\Omega$	1mm
	VLF4012AT-2R2 M1R5	2.2 $\mu\text{H}$	1500mA	0.076 $\Omega$	1.2mm
	VLF5012ST-3R3 M1R7	3.3 $\mu\text{H}$	1700mA	0.095 $\Omega$	1.2mm
	VLF5014ST-2R2 M2R3	2.2 $\mu\text{H}$	2300mA	0.059 $\Omega$	1.4mm

## APPLICATIONS INFORMATION

### Input Capacitor ( $C_{IN}$ ) Selection

In continuous mode, the input current of the converter is a square wave with a duty cycle of approximately  $V_{OUT}/V_{IN}$ . To prevent large voltage transients, a low equivalent series resistance (ESR) input capacitor sized for the maximum RMS current must be used. The maximum RMS capacitor current is given by:

$$I_{RMS} \approx I_{MAX} \frac{\sqrt{V_{OUT}(V_{IN} - V_{OUT})}}{V_{IN}}$$

Where the maximum average output current  $I_{MAX}$  equals the peak current minus half the peak-to-peak ripple current,  $I_{MAX} = I_{LIM} - \Delta I_L / 2$ . This formula has a maximum at  $V_{IN} = 2V_{OUT}$ , where  $I_{RMS} = I_{OUT} / 2$ . This simple worst-case is commonly used to design because even significant deviations do not offer much relief. Note that capacitor manufacturer's ripple current ratings are often based on only 2000 hours lifetime. This makes it advisable to further derate the capacitor, or choose a capacitor rated at a higher temperature than required. Several capacitors may also be paralleled to meet the size or height requirements of the design. An additional 0.1 $\mu$ F to 1 $\mu$ F ceramic capacitor is also recommended on  $V_{IN}$  for high frequency decoupling when not using an all-ceramic capacitor solution.

### Output Capacitor ( $C_{OUT}$ ) Selection

The selection of  $C_{OUT}$  is driven by the required effective series resistance (ESR). Typically, once the ESR requirement for  $C_{OUT}$  has been met, the RMS current rating generally far exceeds the  $I_{RIPPLE(P-P)}$  requirement. The output ripple  $\Delta V_{OUT}$  is determined by:

$$\Delta V_{OUT} \approx \Delta I_L \left( ESR + \frac{1}{8f_0 C_{OUT}} \right)$$

where  $f_0$  = operating frequency,  $C_{OUT}$  = output capacitance and  $\Delta I_L$  = ripple current in the inductor. For a fixed output voltage, the output ripple is highest at maximum input voltage since  $\Delta I_L$  increases with input voltage.

If tantalum capacitors are used, it is critical that the capacitors are surge tested for use in switching power supplies. An excellent choice is the AVX TPS series of surface mount tantalum. These are specially constructed and tested for low ESR so they give the lowest ESR for a given volume. Other

capacitor types include Sanyo POSCAP, Kemet T510 and T495 series, and Sprague 593D and 595D series. Consult the manufacturer for other specific recommendations.

### Using Ceramic Input and Output Capacitors

Higher values, lower cost ceramic capacitors are now becoming available in smaller case sizes. Their high ripple current, high voltage rating and low ESR make them ideal for switching regulator applications. Because the LTC3619B control loop does not depend on the output capacitor's ESR for stable operation, ceramic capacitors can be used freely to achieve very low output ripple and small circuit size.

However, care must be taken when ceramic capacitors are used at the input. When a ceramic capacitor is used at the input and the power is supplied by a wall adapter through long wires, a load step at the output can induce ringing at the input,  $V_{IN}$ . At best, this ringing can couple to the output and be mistaken as loop instability. At worst, a sudden inrush of current through the long wires can potentially cause a voltage spike at  $V_{IN}$ , large enough to damage the part. For more information, see Application Note 88.

When choosing the input and output ceramic capacitors, choose the X5R or X7R dielectric formulations. These dielectrics have the best temperature and voltage characteristics of all the ceramics for a given value and size.

### Setting the Output Voltage

The LTC3619B regulates the  $V_{FB1}$  and  $V_{FB2}$  pins to 0.6V during regulation. Thus, the output voltage is set by a resistive divider, Figure 2, according to the following formula:

$$V_{OUT} = 0.6V \left( 1 + \frac{R2}{R1} \right) \quad (2)$$

Keeping the current small (<10 $\mu$ A) in these resistors maximizes efficiency, but making it too small may allow stray capacitance to cause noise problems or reduce the phase margin of the error amp loop.

To improve the frequency response of the main control loop, a feedback capacitor ( $C_F$ ) may also be used. Great care should be taken to route the  $V_{FB}$  line away from noise sources, such as the inductor or the SW line.

## APPLICATIONS INFORMATION

### Checking Transient Response

The regulator loop response can be checked by looking at the load transient response. Switching regulators take several cycles to respond to a step in load current. When a load step occurs,  $V_{OUT}$  immediately shifts by an amount equal to  $\Delta I_{LOAD} \cdot ESR$ , where ESR is the effective series resistance of  $C_{OUT}$ .  $\Delta I_{LOAD}$  also begins to charge or discharge  $C_{OUT}$  generating a feedback error signal used by the regulator to return  $V_{OUT}$  to its steady-state value. During this recovery time,  $V_{OUT}$  can be monitored for overshoot or ringing that would indicate a stability problem.

The initial output voltage step may not be within the bandwidth of the feedback loop, so the standard second order overshoot/DC ratio cannot be used to determine the phase margin. In addition, feedback capacitors ( $C_{F1}$  and  $C_{F2}$ ) can be added to improve the high frequency response, as shown in Figure 2. Capacitor  $C_F$  provides phase lead by creating a high frequency zero with R2 which improves the phase margin.

The output voltage settling behavior is related to the stability of the closed-loop system and will demonstrate the actual overall supply performance. For a detailed explanation of optimizing the compensation components, including a review of control loop theory, refer to Application Note 76.

In some applications, a more severe transient can be caused by switching in loads with large ( $>1\mu F$ ) input capacitors. The discharged input capacitors are effectively put in parallel with  $C_{OUT}$ , causing a rapid drop in  $V_{OUT}$ . No regulator can deliver enough current to prevent this problem if the switch connecting the load has low resistance and is driven quickly. The solution is to limit the turn-on speed of the load switch driver. A Hot Swap™ controller is designed specifically for this purpose and usually incorporates current limiting, short-circuit protection, and soft-starting.

### Efficiency Considerations

The percent efficiency of a switching regulator is equal to the output power divided by the input power times 100%. It is often useful to analyze individual losses to determine what is limiting the efficiency and which change would

produce the most improvement. Percent efficiency can be expressed as:

$$\% \text{ Efficiency} = 100\% - (L1 + L2 + L3 + \dots)$$

where L1, L2, etc., are the individual losses as a percentage of input power.

Although all dissipative elements in the circuit produce losses, four sources usually account for the losses in LTC3619B circuits: 1)  $V_{IN}$  quiescent current, 2) switching losses, 3)  $I^2R$  losses, 4) other system losses.

1. The  $V_{IN}$  current is the DC supply current given in the Electrical Characteristics which excludes MOSFET driver and control currents.  $V_{IN}$  current results in a small ( $<0.1\%$ ) loss that increases with  $V_{IN}$ , even at no load.
2. The switching current is the sum of the MOSFET driver and control currents. The MOSFET driver current results from switching the gate capacitance of the power MOSFETs. Each time a MOSFET gate is switched from low to high to low again, a packet of charge  $dQ$  moves from  $V_{IN}$  to ground. The resulting  $dQ/dt$  is a current out of  $V_{IN}$  that is typically much larger than the DC bias current. In continuous mode,  $I_{GATECHG} = f_O(Q_T + Q_B)$ , where  $Q_T$  and  $Q_B$  are the gate charges of the internal top and bottom MOSFET switches. The gate charge losses are proportional to  $V_{IN}$  and thus their effects will be more pronounced at higher supply voltages.
3.  $I^2R$  losses are calculated from the DC resistances of the internal switches,  $R_{SW}$ , and external inductor,  $R_L$ . In continuous mode, the average output current flows through inductor L, but is “chopped” between the internal top and bottom switches. Thus, the series resistance looking into the SW pin is a function of both top and bottom MOSFET  $R_{DS(ON)}$  and the duty cycle (DC) as follows:

$$R_{SW} = (R_{DS(ON)TOP}) \cdot (DC) + (R_{DS(ON)BOT}) \cdot (1 - DC)$$

The  $R_{DS(ON)}$  for both the top and bottom MOSFETs can be obtained from the Typical Performance Characteristics curves. Thus, to obtain  $I^2R$  losses:

$$I^2R \text{ losses} = I_{OUT}^2 \cdot (R_{SW} + R_L)$$



## APPLICATIONS INFORMATION

4. Other “hidden” losses, such as copper trace and internal battery resistances, can account for additional efficiency degradations in portable systems. It is very important to include these “system” level losses in the design of a system. The internal battery and fuse resistance losses can be minimized by making sure that  $C_{IN}$  has adequate charge storage and very low ESR at the switching frequency. Other losses, including diode conduction losses during dead-time, and inductor core losses, generally account for less than 2% total additional loss.

### Thermal Considerations

In a majority of applications, the LTC3619B does not dissipate much heat due to its high efficiency. In the unlikely event that the junction temperature somehow reaches approximately 150°C, both power switches will be turned off and the SW node will become high impedance. The goal of the following thermal analysis is to determine whether the power dissipated causes enough temperature rise to exceed the maximum junction temperature (125°C) of the part. The temperature rise is given by:

$$T_{RISE} = P_D \cdot \theta_{JA}$$

where  $P_D$  is the power dissipated by the regulator and  $\theta_{JA}$  is the thermal resistance from the junction of the die to the ambient temperature. The junction temperature,  $T_J$ , is given by:

$$T_J = T_{RISE} + T_{AMBIENT}$$

As a worst-case example, consider the case when the LTC3619B is in dropout on both channels at an input voltage of 2.7V with a load current of 400mA and 800mA and an ambient temperature of 70°C. From the Typical Performance Characteristics graph of Switch Resistance, the  $R_{DS(ON)}$  of the switch is 0.56Ω and 0.33Ω. Therefore, power dissipated by each channel is:

$$P_{D1} = I_{OUT}^2 \cdot R_{DS(ON)} = 90mW$$

$$P_{D2} = I_{OUT}^2 \cdot R_{DS(ON)} = 212mW$$

Given that the thermal resistance of a properly soldered DFN package is approximately 40°C/W, the junction temperature of an LTC3619B device operating in a 70°C ambient temperature is approximately:

$$T_J = (0.302W \cdot 40°C/W) + 70°C = 82.1°C$$

which is well below the absolute maximum junction temperature of 125°C.

### PC Board Layout Considerations

When laying out the printed circuit board, the following checklist should be used to ensure proper operation of the LTC3619B. These items are also illustrated graphically in the layout diagrams of Figures 3a and 3b. Check the following in your layout:

1. Does the capacitor  $C_{IN}$  connect to the power  $V_{IN}$  (Pin 6) and GND (Pin 11) as closely as possible? This capacitor provides the AC current of the internal power MOSFETs and their drivers.
2. Are the respective  $C_{OUT}$  and L closely connected? The (–) plate of  $C_{OUT}$  returns current to GND and the (–) plate of  $C_{IN}$ .
3. The resistor divider, R1 and R2, must be connected between the (+) plate of  $C_{OUT1}$  and a ground sense line terminated near GND (Pin 11). The feedback signals  $V_{FB1}$  and  $V_{FB2}$  should be routed away from noisy components and traces, such as the SW lines (Pins 5 and 7), and their trace length should be minimized.
4. Keep sensitive components away from the SW pins, if possible. The input capacitor  $C_{IN}$ ,  $C_{LIM}$  and the resistors R1, R2, R3 and R4 and  $R_{LIM}$  should be routed away from the SW traces and the inductors.
5. A ground plane is preferred, but if not available, keep the signal and power grounds segregated with small signal components returning to the GND pin at a single point. These ground traces should not share the high current path of  $C_{IN}$  or  $C_{OUT}$ .
6. Flood all unused areas on all layers with copper. Flooding with copper will reduce the temperature rise of power components. These copper areas should be connected to  $V_{IN}$  or GND.



APPLICATIONS INFORMATION

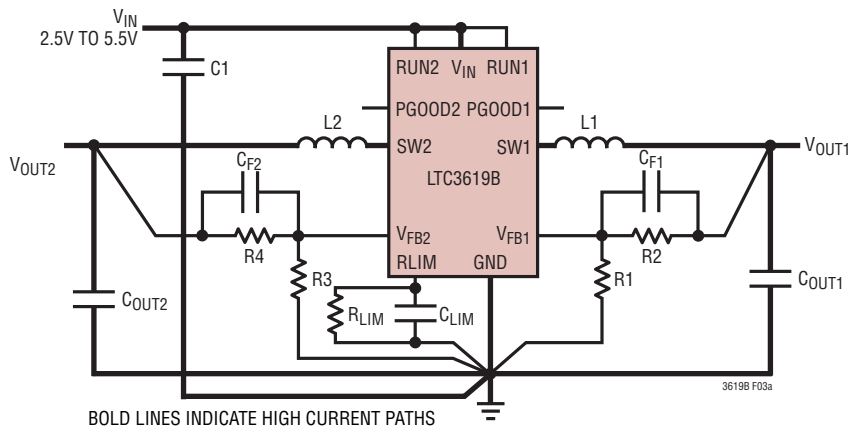

Figure 3a. LTC3619B Layout Diagram (See Board Layout Checklist)

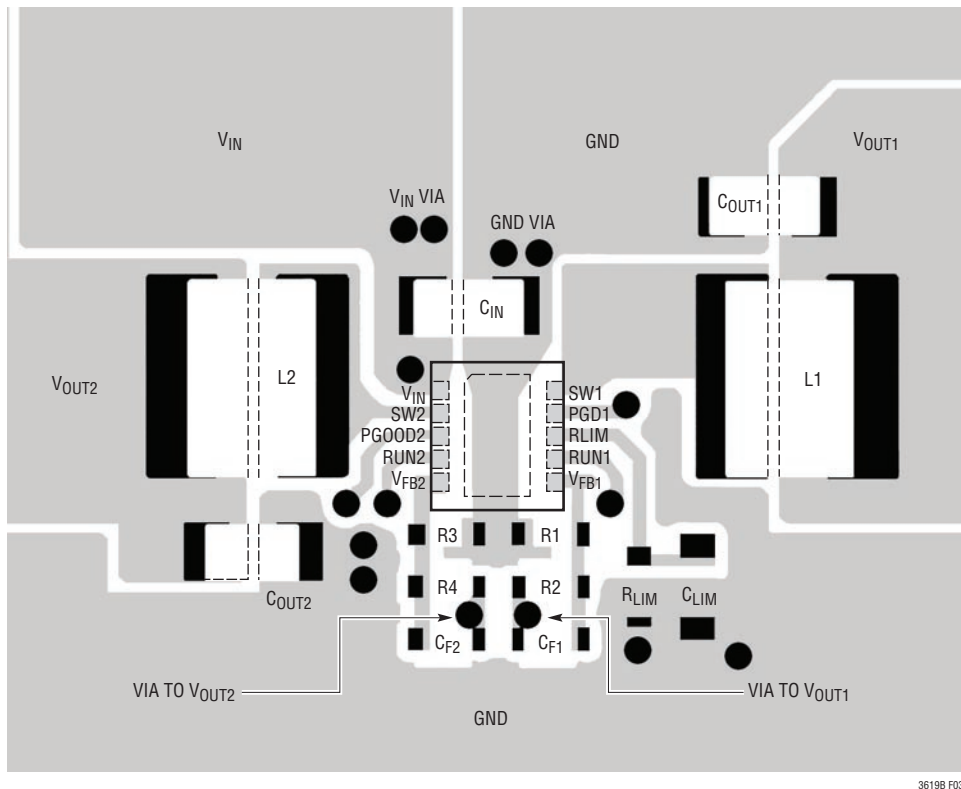

Figure 3b. LTC3619B Suggested Layout

## APPLICATIONS INFORMATION

### Design Example

As a design example, consider using the LTC3619B in a USB-GSM application, with  $V_{IN} = 5V$ ,  $I_{INMAX} = 500mA$ , with the output of channel 2 charging a SuperCap of 4.4mF. The load on each channel requires a maximum of 400mA and 800mA in active mode and 2mA in standby mode. The output voltages are  $V_{OUT1} = 1.8V$  and  $V_{OUT2} = 3.4V$ .

Start with channel 1. First, calculate the inductor value for about 40% ripple current (160mA in this example) at maximum  $V_{IN}$ . Using a derivation of Equation 1:

$$L1 = \frac{1.8V}{2.25MHz \cdot (160mA)} \cdot \left(1 - \frac{1.8V}{5V}\right) = 3.2\mu H$$

For the inductor, use the closest standard value of 3.3 $\mu H$ .

A 10 $\mu F$  ceramic capacitor should be more than sufficient for this output capacitor. As for the input capacitor, a typical value of  $C_{IN} = 10\mu F$  should suffice, if the source impedance is very low.

The feedback resistors program the output voltage. To maintain high efficiency at light loads, the current in these

resistors should be kept small. Choosing 10 $\mu A$  with the 0.6V feedback voltage makes  $R1 \sim 60k$ . A close standard 1% resistor is 59k. Using Equation 2.

$$R2 = \left(\frac{V_{OUT}}{0.6} - 1\right) \cdot R1 = 118k$$

An optional 22pF feedback capacitor ( $C_{F1}$ ) may be used to improve transient response.

Using the same analysis for channel 2 ( $V_{OUT2} = 3.4V$ ), the results are:

$$L2 = 1.5\mu H$$

$$R3 = 59k$$

$$R4 = 276k$$

A feed forward capacitor is not used on channel 2 since the 4.4mF SuperCap will inhibit any fast output voltage transients. Figure 4 shows the complete schematic for this example, along with the efficiency curve and transient response. Input current limit is set at 475mA average current,  $R_{LIM} = 116k$ ,  $C_{LIM} = 2200pF$ . See Programming Input Current Limit section for selecting  $R_{LIM}$  and Selection of  $C_{LIM}$  Capacitance section for  $C_{LIM}$ .

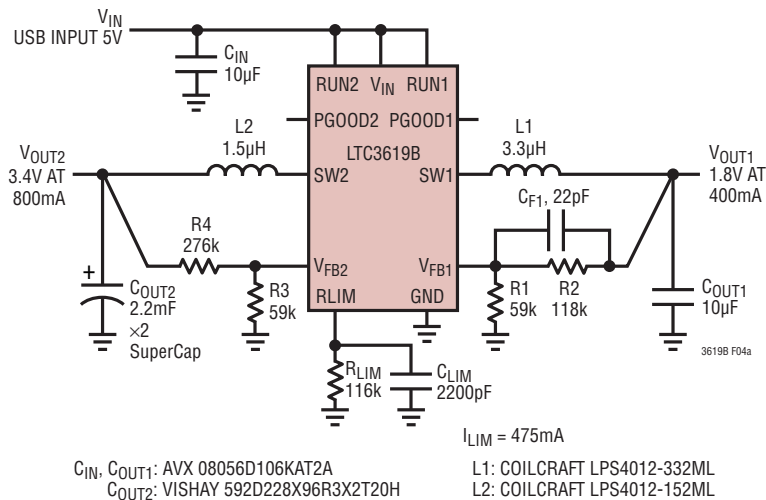

Figure 4a. Design Example Circuit

# APPLICATIONS INFORMATION

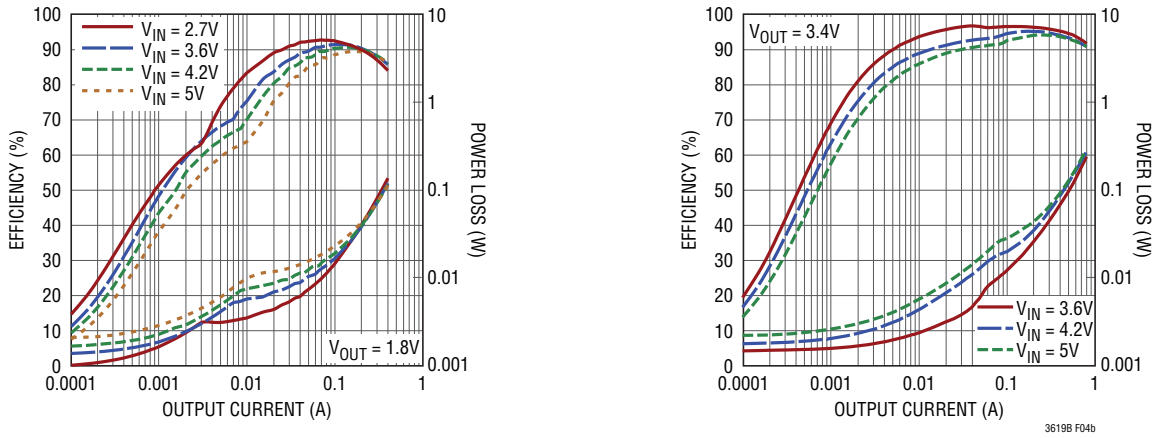

Figure 4b. Efficiency vs Output Current

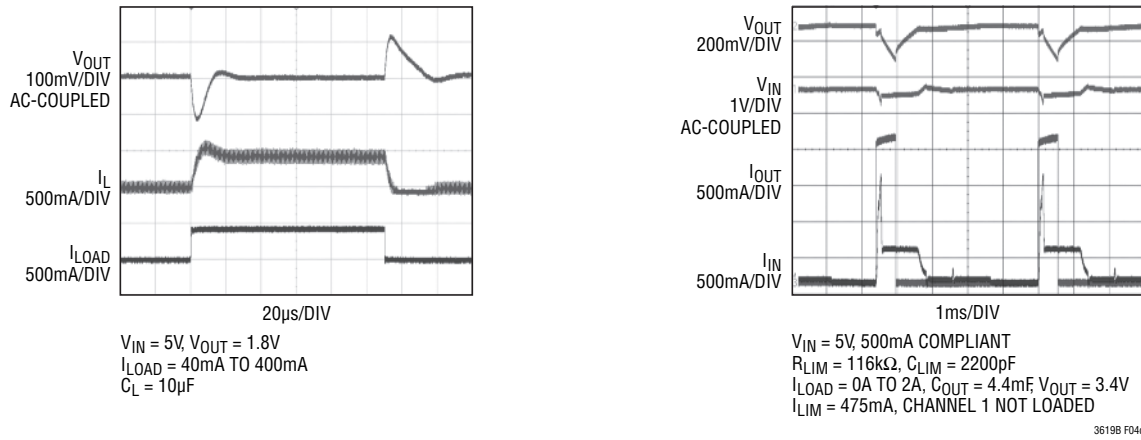
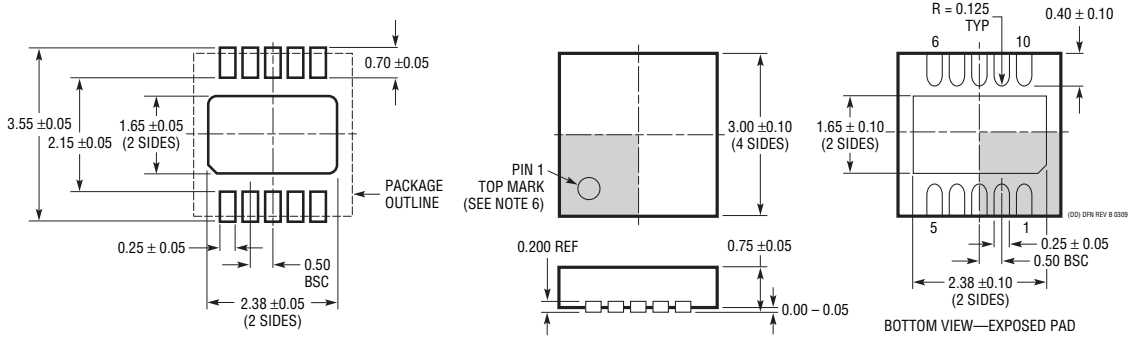

Figure 4c. Transient Response

**PACKAGE DESCRIPTION**

**DD Package**  
**10-Lead Plastic DFN (3mm × 3mm)**  
 (Reference LTC DWG # 05-08-1699 Rev B)



RECOMMENDED SOLDER PAD PITCH AND DIMENSIONS

NOTE:

1. DRAWING TO BE MADE A JEDEC PACKAGE OUTLINE M0-229 VARIATION OF (WEED-2). CHECK THE LTC WEBSITE DATA SHEET FOR CURRENT STATUS OF VARIATION ASSIGNMENT
2. DRAWING NOT TO SCALE
3. ALL DIMENSIONS ARE IN MILLIMETERS
4. DIMENSIONS OF EXPOSED PAD ON BOTTOM OF PACKAGE DO NOT INCLUDE MOLD FLASH. MOLD FLASH, IF PRESENT, SHALL NOT EXCEED 0.15mm ON ANY SIDE
5. EXPOSED PAD SHALL BE SOLDER PLATED
6. SHADED AREA IS ONLY A REFERENCE FOR PIN 1 LOCATION ON THE TOP AND BOTTOM OF PACKAGE

**MSE Package**  
**10-Lead Plastic MSOP, Exposed Die Pad**  
 (Reference LTC DWG # 05-08-1664 Rev C)

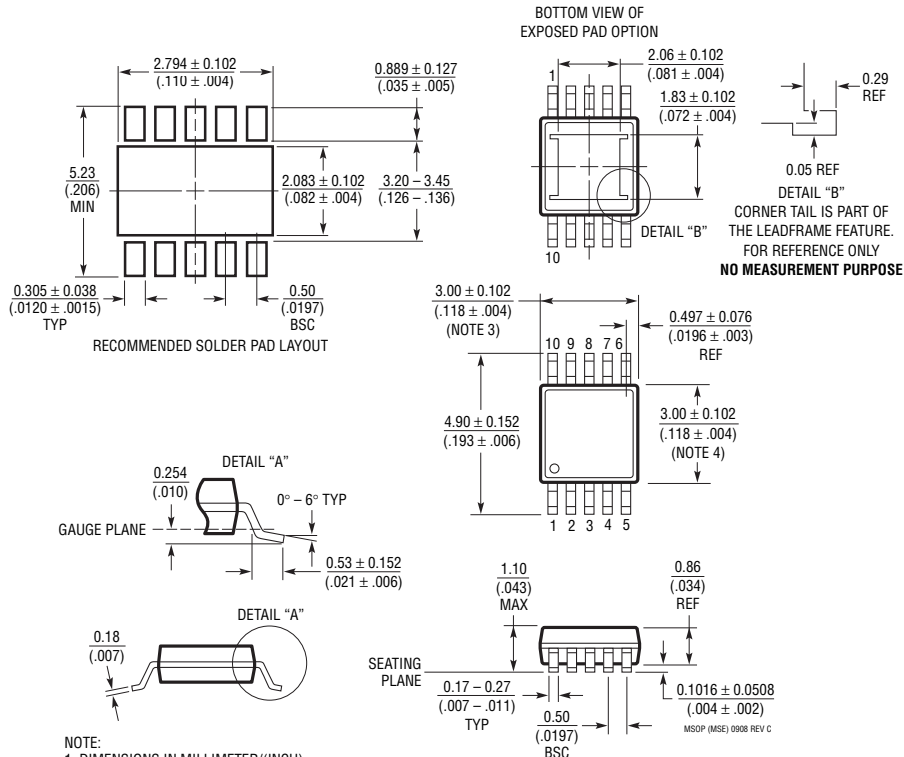

NOTE:

1. DIMENSIONS IN MILLIMETER/(INCH)
2. DRAWING NOT TO SCALE
3. DIMENSION DOES NOT INCLUDE MOLD FLASH, PROTRUSIONS OR GATE BURRS. MOLD FLASH, PROTRUSIONS OR GATE BURRS SHALL NOT EXCEED 0.152mm (.006") PER SIDE
4. DIMENSION DOES NOT INCLUDE INTERLEAD FLASH OR PROTRUSIONS. INTERLEAD FLASH OR PROTRUSIONS SHALL NOT EXCEED 0.152mm (.006") PER SIDE
5. LEAD COPLANARITY (BOTTOM OF LEADS AFTER FORMING) SHALL BE 0.102mm (.004") MAX

## REVISION HISTORY

REV	DATE	DESCRIPTION	PAGE NUMBER
A	4/10	Changes to Temperature Range in Order Information Section	2
		Updates in the Electrical Characteristics Table	3
		Edit on Y-Axis on Graph G18	5
		Updated DD Package Drawing	18

## TYPICAL APPLICATIONS

### Dual 400mA/800mA Buck Converter, $I_{LIM} = 500mA$

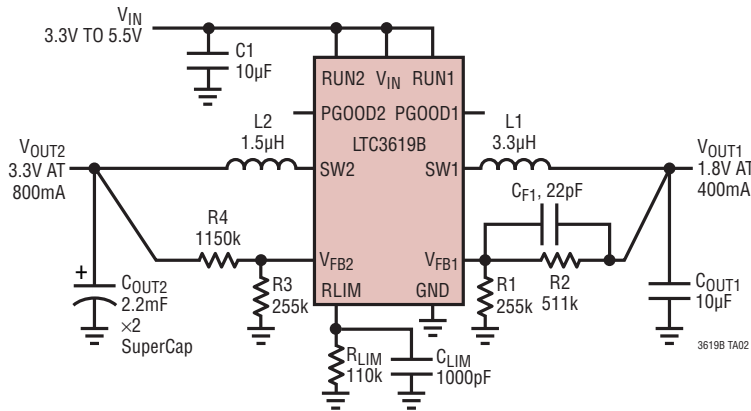

C1, C<sub>OUT1</sub>: AVX 08056D106KAT2A  
 C<sub>OUT2</sub>: VISHAY 592D228X96R3X2T20H  
 L1: COILCRAFT LPS4012-332ML  
 L2: COILCRAFT LPS4012-152ML

### Dual 400mA/800mA Buck Converter, $I_{LIM} = 475mA$ or Disabled

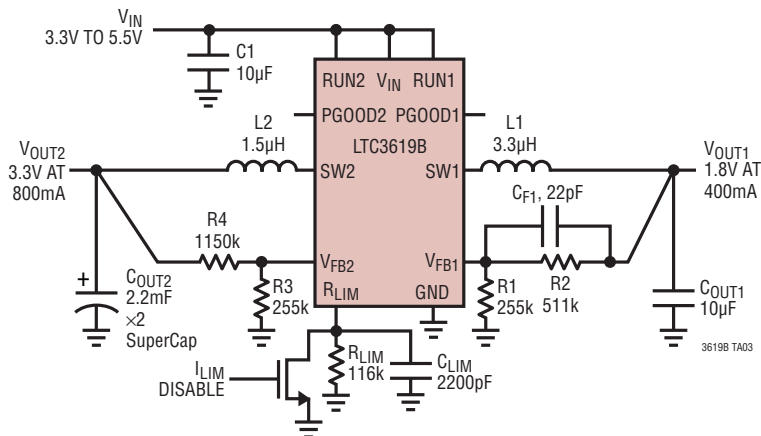

C1, C<sub>OUT1</sub>: AVX 08056D106KAT2A  
 C<sub>OUT2</sub>: VISHAY 592D228X96R3X2T20H  
 L1: COILCRAFT LPS4012-332ML  
 L2: COILCRAFT LPS4012-152ML

## RELATED PARTS

PART NUMBER	DESCRIPTION	COMMENTS
LTC3619	Dual 400mA and 800mA $I_{OUT}$ , 2.25MHz, Synchronous Step-Down DC/DC Converter	95% Efficiency, $V_{IN(MIN)} = 2.5V$ , $V_{IN(MAX)} = 5.5V$ , $V_{OUT(MIN)} = 0.6V$ , $I_Q = 50\mu A$ , $I_{SD} < 1\mu A$ , MS10E, 3mm × 3mm DFN-10
LTC3127	1.2A $I_{OUT}$ , 1.6MHz, Synchronous Buck-Boost DC/DC Converter with Adjustable Input Current Limit	94% Efficiency, $V_{IN(MIN)} = 1.8V$ , $V_{IN(MAX)} = 5.5V$ , $V_{OUT(MAX)} = 5.25V$ , $I_Q = 18\mu A$ , $I_{SD} < 1\mu A$ , 3mm × 3mm DFN-MSOP10E
LTC3125	1.2A $I_{OUT}$ , 1.6MHz, Synchronous Boost DC/DC Converter with Adjustable Input Current Limit	94% Efficiency, $V_{IN(MIN)} = 1.8V$ , $V_{IN(MAX)} = 5.5V$ , $V_{OUT(MAX)} = 5.25V$ , $I_Q = 15\mu A$ , $I_{SD} < 1\mu A$ , 2mm × 3mm DFN-8
LTC3417A/ LTC3417A-2	Dual 1.5A/1A, 4MHz, Synchronous Step-Down DC/DC Converter	95% Efficiency, $V_{IN(MIN)} = 2.3V$ , $V_{IN(MAX)} = 5.5V$ , $V_{OUT(MIN)} = 0.8V$ , $I_Q = 125\mu A$ , $I_{SD} < 1\mu A$ , TSSOP-16E, 3mm × 5mm DFN-16
LTC3407A/ LTC3407A-2	Dual 600mA/600mA, 1.5MHz, Synchronous Step-Down DC/DC Converter	95% Efficiency, $V_{IN(MIN)} = 2.5V$ , $V_{IN(MAX)} = 5.5V$ , $V_{OUT(MIN)} = 0.6V$ , $I_Q = 40\mu A$ , $I_{SD} < 1\mu A$ , MS10E, 3mm × 3mm DFN-10
LTC3548/LTC3548-1/ LTC3548-2	Dual 400mA and 800mA $I_{OUT}$ , 2.25MHz, Synchronous Step-Down DC/DC Converter	95% Efficiency, $V_{IN(MIN)} = 2.5V$ , $V_{IN(MAX)} = 5.5V$ , $V_{OUT(MIN)} = 0.6V$ , $I_Q = 40\mu A$ , $I_{SD} < 1\mu A$ , MS10E, 3mm × 3mm DFN-10
LTC3546	Dual 3A/1A, 4MHz, Synchronous Step-Down DC/DC Converter	95% Efficiency, $V_{IN(MIN)} = 2.3V$ , $V_{IN(MAX)} = 5.5V$ , $V_{OUT(MIN)} = 0.6V$ , $I_Q = 160\mu A$ , $I_{SD} < 1\mu A$ , 4mm × 5mm QFN-28

3619bfa