

FEATURES

- **Dual High Efficiency DC/DC Converters:**
 Step-Up ($V_{OUT} = 1.8V$ to $5.25V$, $I_{SW} = 600mA$)
 Step-Down ($V_{OUT} = 0.615V$ to $5.5V$, $I_{OUT} = 400mA$)
- **1.8V to 5.5V Input Voltage Range**
- **Up to 94% Efficiency**
- **Pin Selectable Burst Mode® Operation**
- **45 μ A Quiescent Current in Burst Mode Operation**
- **1.2MHz (LTC3523) or 2.4MHz (LTC3523-2) Switching Frequency**
- **Independent Power Good Indicator Outputs**
- **Integrated Soft-Start**
- **Thermal and Overcurrent Protection**
- **<3 μ A Quiescent Current in Shutdown**
- **Small 16-Lead 3mm \times 3mm \times 0.75mm QFN Package**

APPLICATIONS

- Digital Cameras
- Medical Instruments
- Industrial Handhelds
- GPS Navigators

DESCRIPTION

The LTC[®]3523/LTC3523-2 combine a 600mA step-up DC/DC converter with a 400mA synchronous step-down DC/DC converter in a tiny 3mm \times 3mm package. The 1.2MHz/2.4MHz switching frequencies minimize the solution footprint while maintaining high efficiency. Both converters feature soft-start and internal compensation, simplifying the design.

Both the step-up and step-down converters are current mode controlled and utilize an internal synchronous rectifier for high efficiency. The step-up supports 0% duty cycle operation and the step-down converter supports 100% duty cycle operation to extend battery run time. If the MODE pin is held high, both converters automatically transition between Burst Mode operation and PWM operation improving light load efficiency. Fixed, low noise 1.2MHz/2.4MHz PWM operation is selected when MODE is grounded.

The LTC3523/LTC3523-2 provide a sub-3 μ A shutdown mode, overtemperature shutdown and current limit protection on both converters. The LTC3523/LTC3523-2 are housed in a 16-lead 3mm \times 3mm \times 0.75mm QFN package.

LT, LTC, LTM and Burst Mode are registered trademarks of Linear Technology Corporation. All other trademarks are the property of their respective owners.

TYPICAL APPLICATION

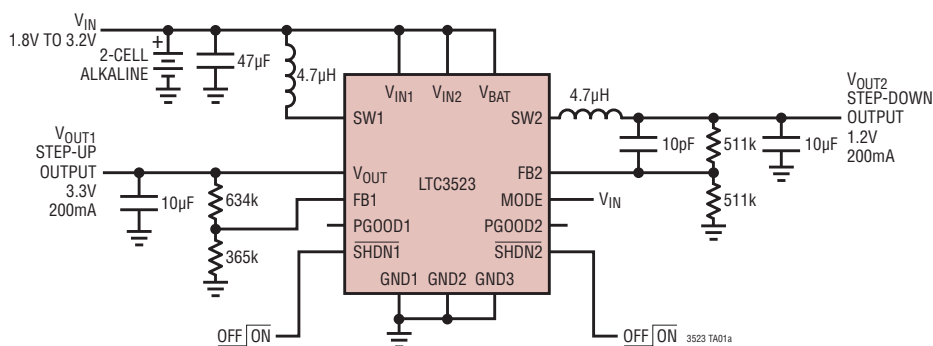

LTC3523 Efficiency and Power Loss vs Load Current

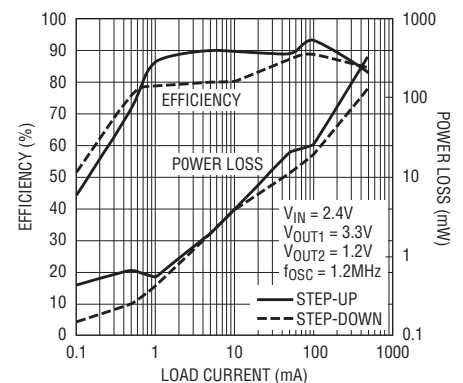

3523 TA01b

3523fb

LTC3523/LTC3523-2

ABSOLUTE MAXIMUM RATINGS

(Note 1)

V_{IN1} , V_{IN2} , V_{BAT} , V_{OUT} Voltages	-0.3V to 6V
$\overline{SHDN1}$, $PGOOD1$, $PGOOD2$, $FB1$ Voltages ..	-0.3V to 6V
$\overline{SHDN2}$, $FB2$, $MODE$ Voltages	-0.3V to ($V_{IN2} + 0.3V$)
$SW1$ Voltage	
DC	0.3V to 6V
Pulse < 100ns	-0.3V to 7V
$SW2$ Voltage Pulse < 100ns	-0.3V to ($V_{IN2} + 0.3V$)
Operating Temperature Range	
(Notes 2, 3)	-40°C to 85°C
Storage Temperature Range	-65°C to 125°C

PIN CONFIGURATION

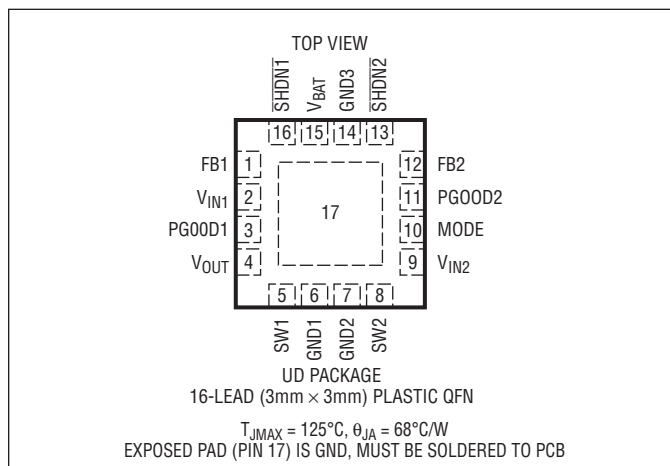

ORDER INFORMATION

LEAD FREE FINISH	TAPE AND REEL	PART MARKING	PACKAGE DESCRIPTION	TEMPERATURE RANGE
LTC3523EUD#PBF	LTC3523EUD#TRPBF	LCYC	16-Lead (3mm × 3mm) Plastic DFN	-40°C to 85°C
LTC3523EUD-2#PBF	LTC3523EUD-2#TRPBF	LDDR	16-Lead (3mm × 3mm) Plastic DFN	-40°C to 85°C

Consult LTC Marketing for parts specified with wider operating temperature ranges.

Consult LTC Marketing for information on non-standard lead based finish parts.

For more information on lead free part marking, go to: <http://www.linear.com/leadfree/>

For more information on tape and reel specifications, go to: <http://www.linear.com/tapeandree/>

ELECTRICAL CHARACTERISTICS

The ● denotes the specifications which apply over the full operating temperature range, otherwise specifications are at $T_A = 25^{\circ}C$. $V_{IN1} = V_{IN2} = V_{BAT} = 2.4V$, $V_{OUT} = 3.3V$, unless otherwise specified.

PARAMETER	CONDITIONS	MIN	TYP	MAX	UNITS	
Minimum Start-Up Voltage	●		1.6	1.8	V	
Frequency	LTC3523	●	0.9	1.2	1.5	MHz
	LTC3523-2	●	1.8	2.4	2.65	MHz
Quiescent Current—Shutdown	$V_{\overline{SHDN1}} = V_{\overline{SHDN2}} = 0V$, $V_{OUT} = 0V$, $V_{IN1} = V_{IN2} = V_{BAT}$		0.5	3	μA	
Quiescent Current—Sleep	Measured from V_{SUPPLY} , $V_{IN1} = V_{IN2} = V_{BAT} = 2.4V$		45		μA	
Quiescent Current V_{OUT} —Sleep	Measured from $V_{OUT} = 3.3V$ (Note 4)		15		μA	
$\overline{SHDN1}$, $\overline{SHDN2}$ Input High		1			V	
$\overline{SHDN1}$, $\overline{SHDN2}$ Input Low				0.35	V	
$\overline{SHDN1}$, $\overline{SHDN2}$ Input Current	$V_{\overline{SHDN}} = 5.5V$		1.4	2	μA	
$PGOOD1$, $PGOOD2$ Threshold	Referenced to the Feedback Voltage	-6	-9	-14	%	
$PGOOD1$, $PGOOD2$ Low Voltage	$I_{PGOOD} = 1mA$		0.35		V	
$PGOOD1$, $PGOOD2$ Leakage	$V_{PGOOD} = 5.25V$		0.01	1	μA	
$MODE$ Input High		1.0			V	
$MODE$ Input Low				0.35	V	

3523fb

ELECTRICAL CHARACTERISTICS

The ● denotes the specifications which apply over the full operating temperature range, otherwise specifications are at $T_A = 25^\circ\text{C}$. $V_{IN1} = V_{IN2} = V_{BAT} = 2.4\text{V}$, $V_{OUT} = 3.3\text{V}$, unless otherwise specified.

PARAMETER	CONDITIONS		MIN	TYP	MAX	UNITS
MODE Leakage Current	$V_{MODE} = 5.5\text{V}$			0.01	1	μA
Soft-Start Time				500		μs
Step-Up Converter						
Input Voltage Range		●	1.8		5.25	V
Output Voltage Adjust Range	(Note 6)	●	1.8		5.25	V
Feedback Voltage FB1		●	1.16	1.20	1.23	V
Feedback Input Current FB1	$V_{FB1} = 1.25\text{V}$			0	50	nA
N-Channel Switch Leakage	$V_{SW} = 5.5\text{V}$			0.20	2	μA
P-Channel Switch Leakage	$V_{SW} = 5.5\text{V}$, $V_{OUT} = 0\text{V}$			0.20	2	μA
N-Channel Switch On Resistance	$V_{OUT} = 3.3\text{V}$ $V_{OUT} = 5\text{V}$			0.36 0.22		Ω Ω
P-Channel Switch On Resistance	$V_{OUT} = 3.3\text{V}$, $I_{SW} = 100\text{mA}$ $V_{OUT} = 5\text{V}$, $I_{SW} = 100\text{mA}$			0.33 0.31		Ω Ω
Peak Inductor Current	(Note 7)	●	600	1000		mA
Current Limit Delay to Output	(Note 6)			40		ns
Maximum Duty Cycle	$V_{FB} = 1\text{V}$	●	80	87		%
Minimum Duty Cycle	$V_{FB} = 1.5\text{V}$	●			0	%
Step-Down Converter						
Input Voltage Range		●	1.8		5.5	V
Output Voltage Range	(Note 6)	●	0.615		5.5	V
Feedback Voltage FB2		●	585	600	615	mV
Feedback Input Current FB2	$V_{FB2} = 0.625\text{V}$			0	50	nA
Reference Voltage Line Regulation	$I_{OUT} = 100\text{mA}$ (Notes 5, 6)			0.04		%/V
Output Voltage Line Regulation	$I_{OUT} = 100\text{mA}$, $1.6\text{V} < V_{IN} < 5.5\text{V}$ (Note 6)			0.04		%/V
Output Voltage Load Regulation	$I_{OUT} = 0\text{mA}$ to 600mA (Note 6)			1.0		%
Maximum Duty Cycle				100		%
Peak Inductor Current	(Note 7)	●	400	650		mA
N-Channel Switch On Resistance	$V_{IN2} = 2.4\text{V}$			0.33		Ω
P-Channel Switch On Resistance	$V_{IN2} = 2.4\text{V}$			0.58		Ω
SW Leakage	$V_{SHDN2} = 0\text{V}$, $V_{SW2} = 0\text{V}$ or 5V , $V_{IN2} = 5.5\text{V}$			0.20	2	μA

Note 1: Stresses beyond those listed under Absolute Maximum Ratings may cause permanent damage to the device. Exposure to any Absolute Maximum Rating condition for extended periods may affect device reliability and lifetime.

Note 2: The LTC3523/LTC3523-2 are guaranteed to meet performance specifications from 0°C to 85°C . Specifications over the -40°C to 85°C operating temperature range are assured by design, characterization and correlation with statistical process control.

Note 3: The LTC3523/LTC3523-2 include an overtemperature shutdown that is intended to protect the device during momentary overload conditions. Junction temperature will exceed 125°C when the overtemperature shutdown is active. Continuous operation above the specified maximum operating junction temperature may impair device reliability.

Note 4: Current is measured into the V_{OUT} pin since the supply is bootstrapped to the output for the step-up. The current will reflect to the input supply by: $(V_{OUT}/V_{IN}) \cdot \text{Efficiency}$. The outputs are not switching in sleep.

Note 5: The LTC3523/LTC3523-2 are tested in a propriety test mode that connects FB2 to the output of the error amplifier.

Note 6: Specification is guaranteed by design and not 100% tested in production.

Note 7: Current measurements are performed when the LTC3523/LTC3523-2 are not switching. The current limit values in operation will be somewhat higher due to the propagation delay of the comparator.

TYPICAL PERFORMANCE CHARACTERISTICS (T_A = 25°C unless otherwise noted)

Normalized FBx Reference vs Temperature

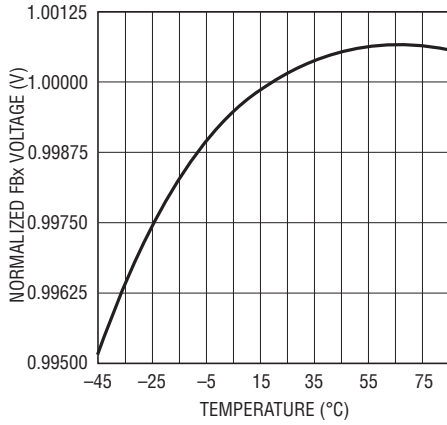

3523 G01

Normalized Oscillator Frequency vs Temperature

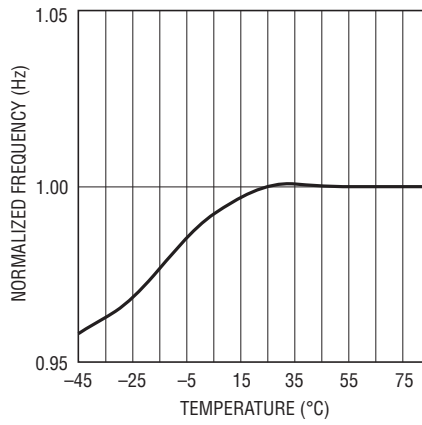

3523 G02

Inrush Current Control for the Step-Up Converter

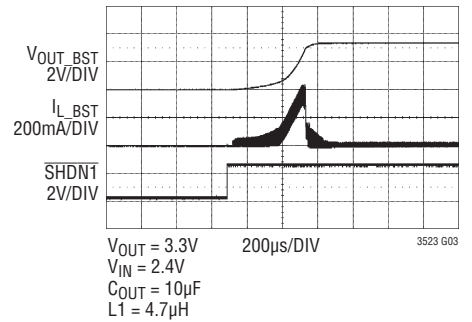

Inrush Current Control for the Step-Down Converter

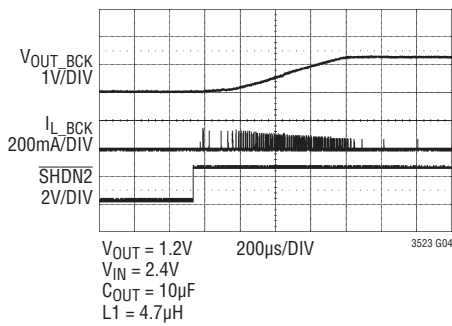

3523 G04

Load Transient Response Step-Up

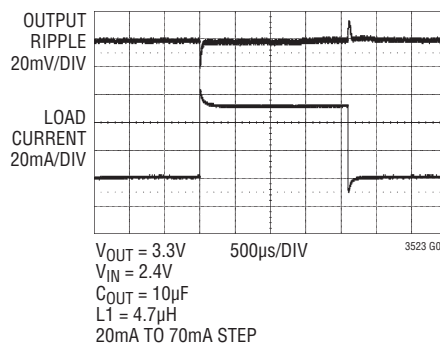

3523 G05

Load Transient Response Step-Down

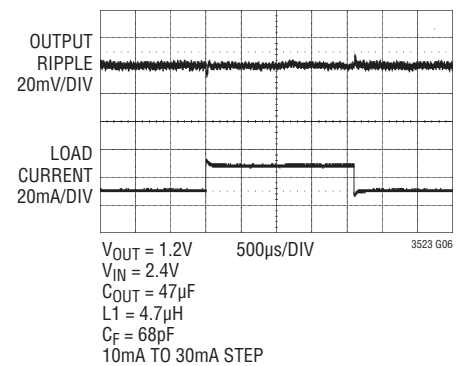

3523 G06

Current Limit vs Temperature

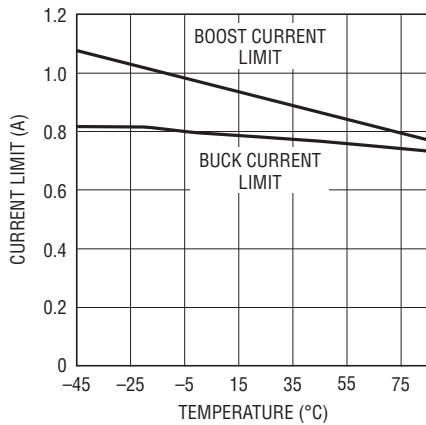

3523 G07

R_{DS(ON)} vs Input Voltage for the Step-Down Converter

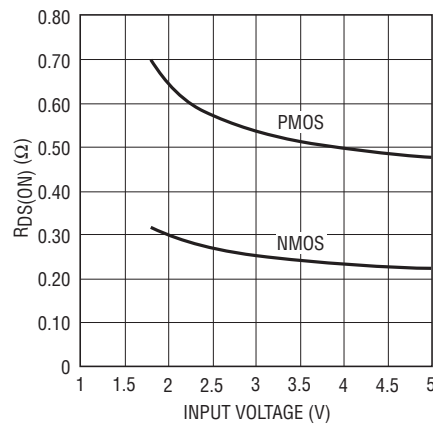

3523 G08

R_{DS(ON)} vs Output Voltage for the Step-Up Converter

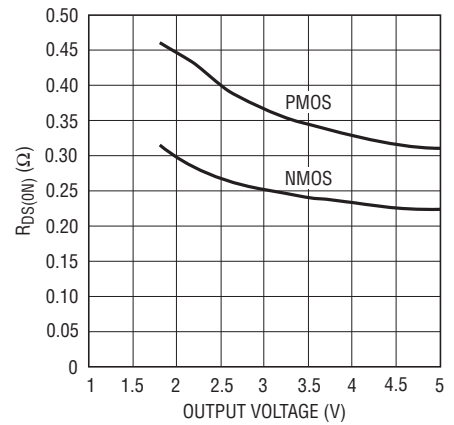

3523 G09

TYPICAL PERFORMANCE CHARACTERISTICS ($T_A = 25^\circ\text{C}$ unless otherwise noted)

Normalized $R_{DS(ON)}$ vs Temperature

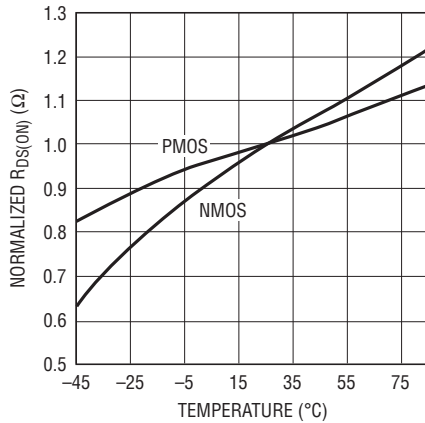

3523 G10

Step-Up No-Load Input Current vs V_{IN}

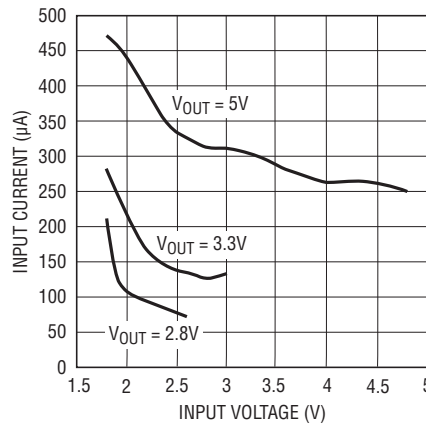

3523 G11

Mode Transition Response

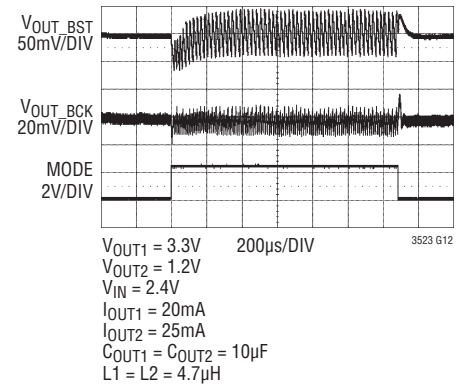

3523 G12

Maximum I_{OUT} vs V_{IN} for the Step-Up Converter

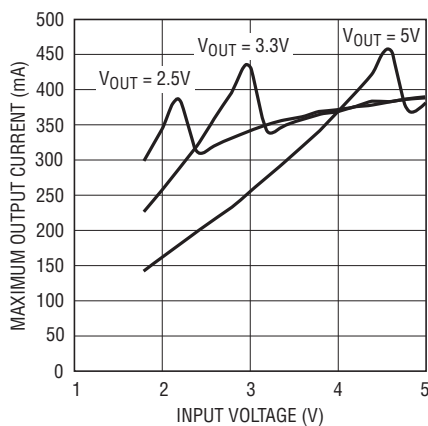

3523 G13

Maximum I_{OUT} vs V_{IN} for the Step-Down Converter

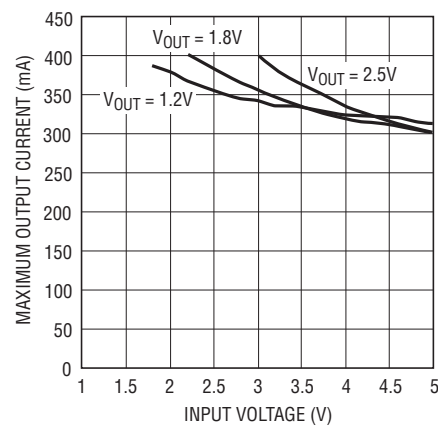

3523 G14

PIN FUNCTIONS

FB1 (Pin 1): Step-Up Converter Feedback Input to the Error Amplifier. Connect resistor divider tap to this pin. The output voltage can be adjusted from 1.8V to 5.25V by:

$$V_{OUT(STEP-UP)} = 1.2V \cdot \left(1 + \frac{R1}{R2}\right)$$

See Block Diagram.

V_{IN1} (Pin 2): Step-Up Converter Power Voltage Input. This pin can be connected to a different supply than V_{IN2} . This pin must be connected to a valid supply voltage.

PGOOD1 (Pin 3): Step-Up Converter Power Good Comparator Output. This open-drain output is pulled low when $V_{FB1} < -9\%$ of its regulation voltage.

V_{OUT} (Pin 4): Step-Up Converter Output Voltage Sense Input and Drain of the Internal Synchronous Rectifier MOSFET. Driver bias is derived from V_{OUT} . PCB trace length from V_{OUT} to the output filter capacitor(s) should be as short and wide as possible.

3523fb

PIN FUNCTIONS

SW1 (Pin 5): Step-Up Converter Switch Pin. Connect the inductor between SW1 and V_{IN1} . Keep these PCB trace lengths as short and wide as possible to reduce EMI and voltage overshoot. If the inductor current falls to zero or $\overline{\text{SHDN1}}$ is low, an internal 150Ω anti-ringing resistor is connected from SW1 to V_{IN1} to minimize EMI.

GND1 (Pin 6): Step-Up Converter Power Ground. Connect this pin to the ground plane.

GND2 (Pin 7): Step-Down Converter Power Ground. Connect this pin to the ground plane.

SW2 (Pin 8): Step-Down Converter Switch Pin. Connect one end of the inductor to SW2. Keep these PCB trace lengths as short and wide as possible to reduce EMI and voltage overshoot.

V_{IN2} (Pin 9): Step-Down Converter Power Voltage Input. This pin can be connected to a different supply than V_{IN1} . This pin must be connected to a valid supply voltage.

MODE (Pin 10): Step-Up and Step-Down Converter Mode Selection Pin. Do not leave this pin floating.

- MODE = Low: PWM mode
- MODE = High: Automatic Burst Mode operation

PGOOD2 (Pin 11): Step-Down Converter Power Good Comparator Output. This open-drain output is pulled low when $V_{FB2} < -9\%$ of its regulation voltage.

FB2 (Pin 12): Step-Down Converter Feedback Input to the Error amplifier. Connect resistor divider tap to this pin. The output voltage can be adjusted from 0.6V to 5.5V by:

$$V_{\text{OUT(STEP-DOWN)}} = 0.6\text{V} \cdot \left(1 + \frac{R3}{R4}\right)$$

See Block Diagram.

If large feedback resistors, above 500k are used, then it will be necessary to use a lead capacitor connected to the output voltage and FB2.

$\overline{\text{SHDN2}}$ (Pin 13): Step-Down Converter Logic Controlled Shutdown Input. Do not leave this pin floating.

- $\overline{\text{SHDN2}}$ = High: Normal free-running operation, 1.2MHz/2.4MHz typical operating frequency.
- $\overline{\text{SHDN2}}$ = Low: Shutdown, quiescent current $< 1\mu\text{A}$.

This pin cannot exceed the voltage on V_{IN2} .

GND3 (Pin 14): Analog Ground. The feedback voltage dividers for each converter must be returned to GND3 for best performance.

Note: When laying out your PCB provide a short direct path between GND1 and the (–) side of the step-up output capacitor(s) and GND2 and the step-down output capacitor. These pins are not connected together internally.

V_{BAT} (Pin 15): Analog Voltage Input. Connect this pin to the higher of V_{IN1} or V_{IN2} .

$\overline{\text{SHDN1}}$ (Pin 16): Step-Up Converter Logic Controlled Shutdown Input.

- $\overline{\text{SHDN1}}$ = High: Normal free-running operation, 1.2MHz/2.4MHz typical operating frequency.
- $\overline{\text{SHDN1}}$ = Low: Shutdown, quiescent current $< 1\mu\text{A}$.

This pin cannot exceed the voltage on V_{IN1} .

Exposed Pad (Pin 17): Die attach pad must be soldered to PCB ground for electrical contact and optimum thermal performance.

BLOCK DIAGRAM

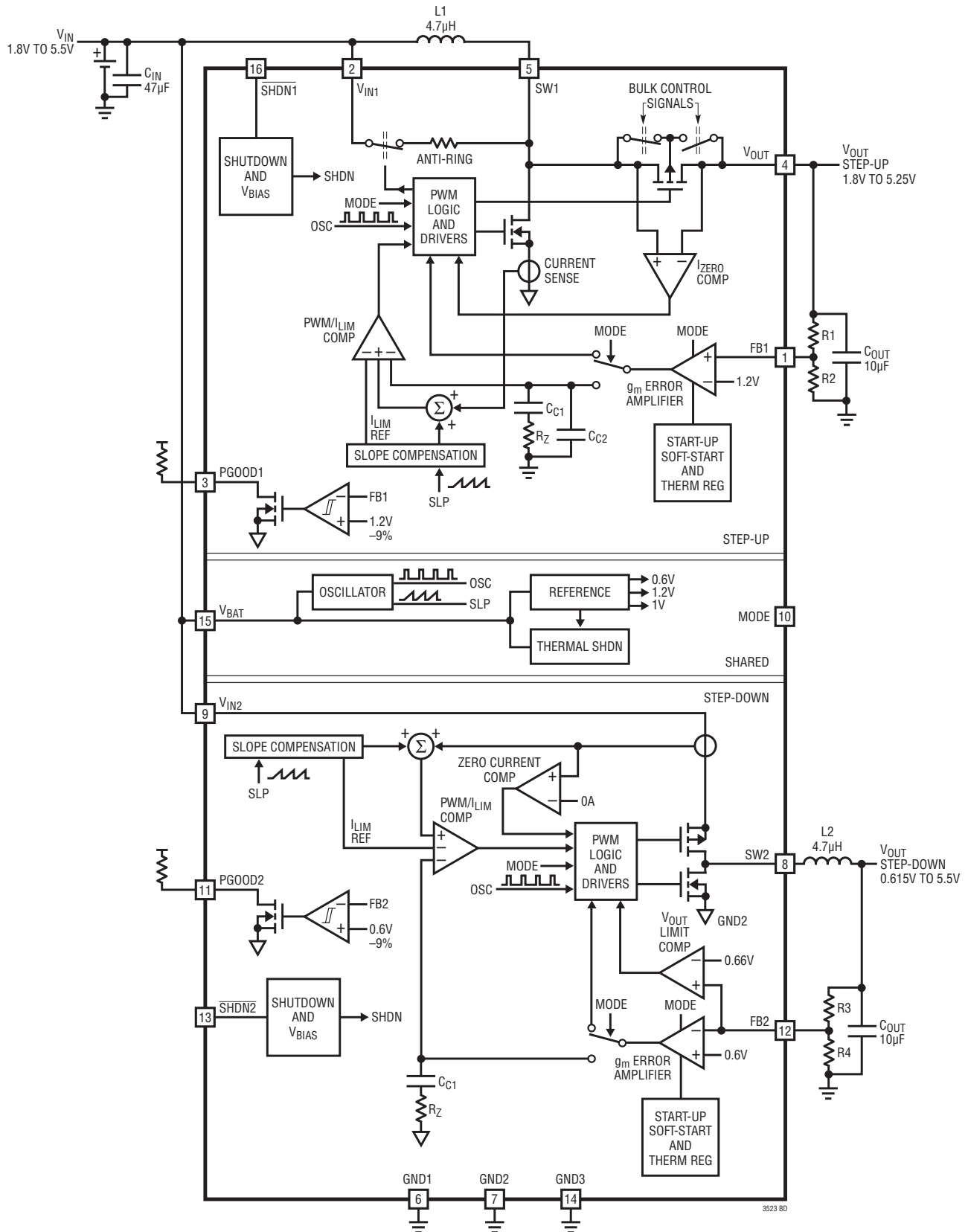

3523 BD

OPERATION

The LTC3523 and LTC3523-2 are synchronous step-up and step-down converters housed in a 16-pin QFN package. Operating from inputs down to 1.8V, the devices feature fixed frequency, current mode PWM control for exceptional line and load regulation and transient response. With low $R_{DS(ON)}$ and internal MOSFET switches, the devices maintain high efficiency over a wide range of load current. Operation can be best understood by referring to the Block Diagram.

Soft-Start

Both the step-up and step-down converters on the LTC3523/LTC3523-2 provide soft-start. The soft-start time is typically 500 μ s. The soft-start function resets in the event of a commanded shutdown or thermal shutdown.

Oscillator

The frequency of operation is set by an internal oscillator to a nominal 1.2MHz for the LTC3523 and nominal 2.4MHz for the LTC3523-2. The oscillator is shared by both converters.

Shutdown

The step-up and the step-down converters have independent shutdown pins. To shut down a converter, pull \overline{SHDNx} below 0.35V. To enable a converter, pull \overline{SHDNx} above 1.0V.

Error Amplifiers

Power converter control loop compensation is provided internally for each converter. The noninverting input is internally connected to the 1.2V reference for the step-up and 0.6V for the step-down. The inverting input is connected to the respective FBx for both converters. Internal clamps limit the minimum and maximum error amp output voltage for improved large signal transient response. A voltage divider from V_{OUT} to ground programs the output voltage via the respective FBx pins from 1.8V to 5.25V for the step-up and 0.615V to 5.5V for the step-down. From the Block Diagram the design equation for programming the output voltages is $V_{OUT} = 1.2V \cdot [1 + (R1/R2)]$ for the step-up and $V_{OUT} = 0.6V \cdot [1 + (R3/R4)]$ for the step-down.

PWM Comparators

The PWM comparators are used to compare the converters external inductor current to the current commanded by the error amplifiers. When the inductor current reaches the current commanded by the error amplifier the inductor charging cycle is terminated and the rectification cycle commences.

Current Limit

The current limit comparator shuts off the N-channel switch for the step-up and P-channel switch for the step-down once its current limit threshold is reached. The current limit comparator delay to output is typically 40ns. Peak switch current is limited to approximately 1000mA for the step-up and 650mA for the step-down independent of input or output voltage.

Zero Current Comparator

The zero current comparator monitors the inductor current to the output and shuts off the synchronous rectifier once this current reduces to approximately 20mA. This prevents the inductor current from reversing in polarity improving efficiency at light loads.

Power Good Comparator

Both converters have independent open drain power good comparators which monitor the output voltage via their respective FBx pins. The comparator output will allow the PGOODx to be pulled up high when the output voltage (V_{OUT}) has exceeded 91% of its final value. If the output voltage decreases below 91%, the comparator will pull the PGOODx pin to ground. The step-up comparator has 3.3% of hysteresis and the step-down has 6.6% relative to FBx voltage for added noise immunity.

Step-Down Overvoltage Comparator

The step-down overvoltage comparator guards against transient overshoots greater than 10% of the output voltage by turning the P-channel switch off until the transient has subsided.

OPERATION

Step-Up Anti-Ringing Control

The anti-ring circuitry connects a resistor across the inductor to prevent high frequency ringing on the SW1 pin during discontinuous current mode operation. The ringing of the resonant circuit formed by L and C_{SW} (capacitance on SW pin) is low energy, but can cause EMI radiation.

Step-Up Output Disconnect

The LTC3523/LTC3523-2 step-up is designed to provide true output disconnect by eliminating body diode conduction of the internal P-channel MOSFET rectifier. This allows for V_{OUT} to go to zero volts during shutdown, drawing no current from the input source. Controlling the P-channel

MOSFET body diode also enables inrush current limiting at turn-on, minimizing surge currents seen by the input supply. Note that to obtain the advantages of output disconnect, an external Schottky diode cannot be connected between SW1 and V_{OUT} .

Thermal Shutdown

If the die temperature reaches 160°C, the part will go into thermal shutdown. All switches will be turned off and the soft-start capacitor will be discharged. The device will be enabled again when the die temperature drops by approximately 15°C.

APPLICATIONS INFORMATION

PCB LAYOUT GUIDELINES

The high speed operation of the LTC3523/LTC3523-2 demands careful attention to board layout. You will not get advertised performance with careless layout. Figure 1 shows the recommended component placement. A large ground pin copper area will help to lower the chip temperature. A multilayer board with a separate ground plane is ideal, but not absolutely necessary.

COMPONENT SELECTION

Inductor Selection

The LTC3523/LTC3523-2 can utilize small surface mount and chip inductors due to its fast 1.2MHz switching frequency and for the 2.4MHz version, the values are halved. The Inductor current ripple is typically set for 20% to 40% of the peak inductor current (I_P). High

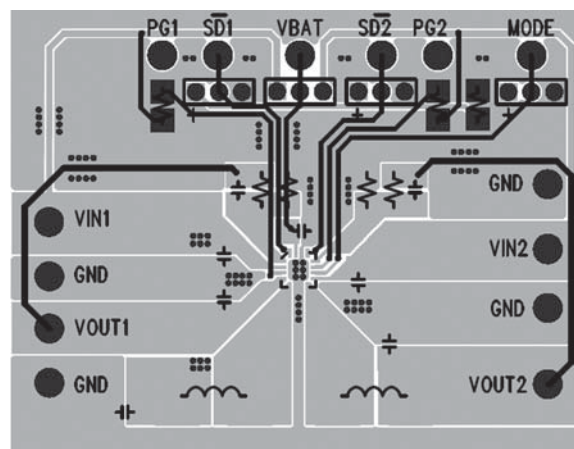

Figure 1. Recommended Component Placement for Double Layer Board

APPLICATIONS INFORMATION

frequency ferrite core inductor materials reduce frequency dependent power losses compared to cheaper powdered iron types, improving efficiency. The inductor should have low ESR (series resistance of the windings) to reduce the I^2R power losses, and must be able to handle the peak inductor current without saturating. Molded chokes and some chip inductors usually do not have enough core to support the peak inductor currents of 1000mA seen on the LTC3523/LTC3523-2. To minimize radiated noise, use a toroid, pot core or shielded bobbin inductor. See Table 1 for suggested inductors and suppliers.

Step-Up: For the step-up converter a minimum inductance value of $3.3\mu\text{H}$ is recommended for 3.6V and lower output voltage applications, and a $4.7\mu\text{H}$ for output voltages greater than 3.6V. Larger values of inductance will allow greater output current capability by reducing the inductor ripple current. Increasing the inductance above $10\mu\text{H}$ will increase size while providing little improvement in output current capability.

Step-Down: For most applications, the value of the inductor will fall in the range of $3.3\mu\text{H}$ to $10\mu\text{H}$, depending upon the amount of current ripple desired. A reasonable point to start is to set the current ripple at 30% of the output current.

Note that larger values of inductance will allow greater output current capability by reducing the inductor ripple

current. Increasing the inductance above $10\mu\text{H}$ will increase size while providing little improvement in output current capability. A $4.7\mu\text{H}$ inductor will work well for most Li-Ion or 2-cell alkaline/NiMH cell applications

Output and Input Capacitor Selection

Low ESR (equivalent series resistance) capacitors should be used to minimize the output voltage ripple. Multilayer ceramic capacitors are an excellent choice as they have extremely low ESR and are available in small footprints.

Step-Up: A $2.2\mu\text{F}$ to $10\mu\text{F}$ output capacitor is sufficient for most applications. Larger values up to $22\mu\text{F}$ may be used to obtain extremely low output voltage ripple and improve transient response. An additional phase lead capacitor connected between V_{OUT} and FB1 may be required with output capacitors larger than $10\mu\text{F}$ to maintain acceptable phase margin. X5R and X7R dielectric materials are preferred for their ability to maintain capacitance over wide voltage and temperature ranges.

Step-Down: Low ESR input capacitors reduce input switching noise and reduce the peak current drawn from the battery. It follows that ceramic capacitors are also a good choice for input decoupling and should be located as close as possible to the device. Table 2 shows the range of acceptable capacitors for a given programmed output voltage. Minimum capacitance values in the table

Table 1. Recommended Inductors

PART	L (μH)	MAXIMUM CURRENT (mA)	DCR (Ω)	DIMENSIONS (mm) (L \times W \times H)	MANUFACTURER
ME3220	4.7 to 15	1200 to 700	0.19 to 0.52	$3.2 \times 2.5 \times 2.0$	Coil Craft www.coilcraft.com
LPS3010	4.7 to 10	720 to 510	0.3 to 0.54	$3.0 \times 3.0 \times 1.0$	
DO2010	4.7 to 15	800 to 510	0.8 to 1.84	$2.0 \times 2.0 \times 1.0$	
SD3112	4.7 to 15	740 to 405	0.25 to 0.65	$3.1 \times 3.1 \times 1.2$	Cooper www.cooperet.com
MIP3226D	4.7 to 10	600 to 200	0.1 to 0.16	$3.2 \times 2.6 \times 1.0$	FDK www.fdk.com
LQH32CN	4.7 to 15	650 to 300	0.15 to 0.58	$3.2 \times 2.5 \times 1.5$	Murata www.murata.com
LQH2MC	4.7 to 15	300 to 200	0.8 to 1.6	$2 \times 1.6 \times 0.9$	
CDRH3D16	4.7 to 15	900 to 450	0.11 to 0.29	$3.8 \times 3.8 \times 1.8$	Sumida www.sumida.com
CDRH2D14	4.7 to 12	680 to 420	0.12 to 0.32	$3.2 \times 3.2 \times 1.5$	
NR3010	4.7 to 15	750 to 400	0.19 to 0.74	$3.0 \times 3.0 \times 1.0$	Taiyo Yuden www.t-yuden.com
NR3015	4.7 to 15	1000 to 560	0.12 to 0.36	$3.0 \times 3.0 \times 1.5$	

APPLICATIONS INFORMATION

will increase loop bandwidth resulting in a faster transient response. Maximum capacitance values will produce lower ripple. Table 3 shows a list of several ceramic capacitor manufacturers. Consult the manufacturers directly for detailed information on their entire selection of ceramic parts.

Table 2. Step-Down Output Capacitor Range vs Programmed Output Voltage

V _{OUT}	MINIMUM CAPACITANCE (μF)	MAXIMUM CAPACITANCE (μF)
0.8	8.4	33.6
1.2	5.6	22.4
1.5	4.5	17.9
1.8	3.7	14.9
2.5	2.7	10.7
5	1.3	5.4

Table 3. Capacitor Vendor Information

SUPPLIER	PHONE	WEBSITE
AVX	(803) 448-9411	www.avxcorp.com
Murata	(714) 852-2001	www.murata.com
Taiyo-Yuden	(408) 573-4150	www.t-yuden.com

STEP-UP V_{IN} > V_{OUT} OPERATION

The LTC3523/LTC3523-2 step-up converters will maintain voltage regulation when the input voltage is above the output voltage. Since this mode will dissipate more power, the maximum output current is limited in order to maintain an acceptable junction temperature and is given by:

$$I_{OUT(MAX)} = \frac{250 - T_A}{136 \cdot [(V_{IN} + 1.5) - V_{OUT}]} T$$

where T_A = ambient temperature.

For example, at V_{IN} = 4.5V, V_{OUT} = 3.3V and T_A = 85°C, the maximum output current is limited to 449mA.

SHORT-CIRCUIT PROTECTION

The LTC3523/LTC3523-2's step-up output disconnect feature allows output short circuit while maintaining a maximum internally set current limit. However, the LTC3523/LTC3523-2 also incorporate internal features such as current limit foldback and thermal shutdown for protection from an excessive overload or short circuit. During a prolonged short circuit of V_{OUT} less than 950mV, the current limit folds back to 2/3 the normal current limit. This 2/3 current limit remains in effect until V_{OUT} exceeds 1V, at which time the normal internal set current limit is restored.

When the LTC3523/LTC3523-2 step-down converters output is shorted to ground, the step-down uses a comparator to limit the current through the synchronous rectifying N-channel switch to 650mA. If this limit is exceeded, the P-channel switch is inhibited from turning on until the current through the synchronous rectifying N-channel switch falls below 650mA.

THERMAL CONSIDERATIONS

To deliver the LTC3523/LTC3523-2's full-rated power, it is imperative that a good thermal path be provided to dissipate the heat generated within the package. This can be accomplished by taking advantage of the large thermal pad on the underside of the LTC3523/LTC3523-2. It is recommended that multiple vias in the printed circuit board be used to conduct heat away from the LTC3523/LTC3523-2 and into the copper plane with as much area as possible. In the event that the junction temperature gets too high, the LTC3523/LTC3523-2 will go into thermal shutdown and all switching will cease until the internal temperature drops to a safe level at which point the soft-start cycle will be initiated.

APPLICATIONS INFORMATION

DUAL BUCK-BOOST AND STEP-UP CONVERTER OPERATION

The LTC3523/LTC3523-2 can be operated in a cascaded configuration as shown in Figure 2, allowing buck-boost and step-up converter operation. Supply rail sequencing is achieved by feeding the step-up converter PGOOD1

into the step-down's $\overline{\text{SHDN2}}$ pin. Note that the overall 3.3V converter efficiency is the product of the individual efficiencies.

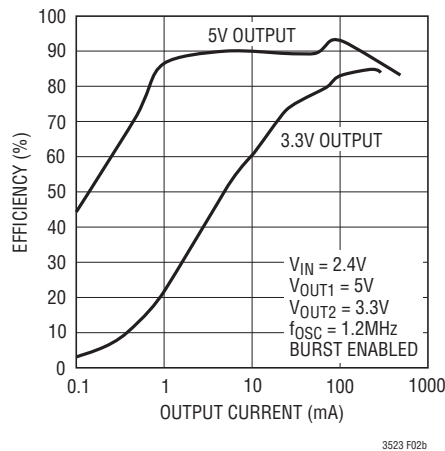
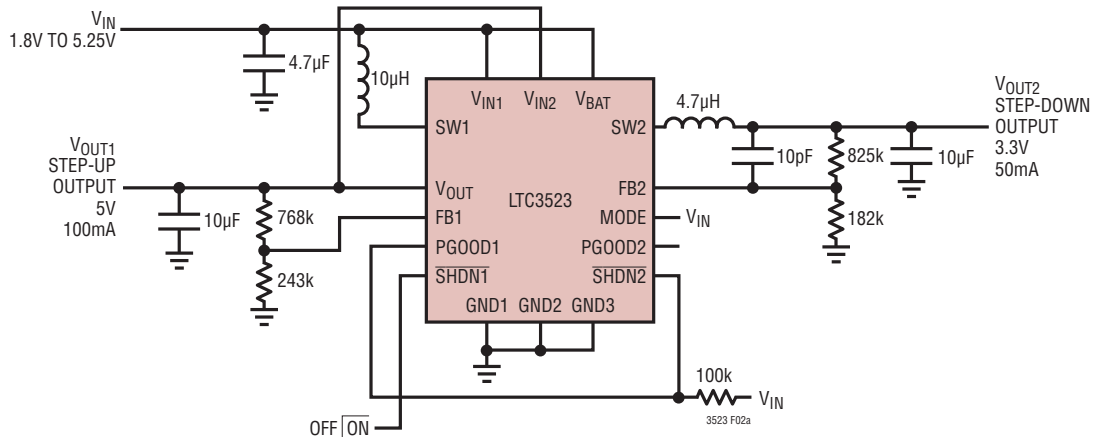
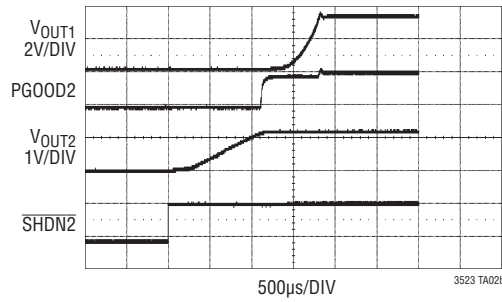
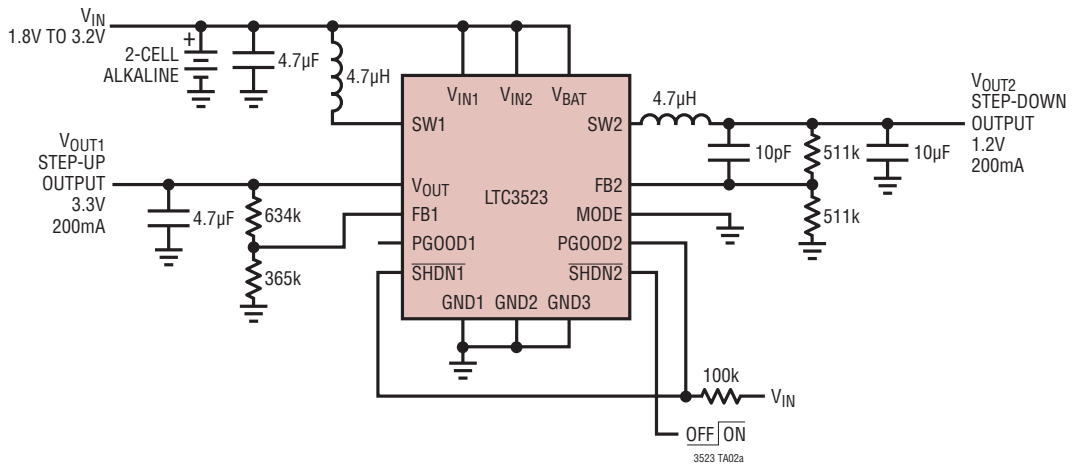

Figure 2. Dual Converter Efficiency (Load Applied to Step-Down Output)

TYPICAL APPLICATIONS

Power Sequence Operation



TYPICAL APPLICATIONS

Li-Ion to 5V/150mA, 2.5V/200mA

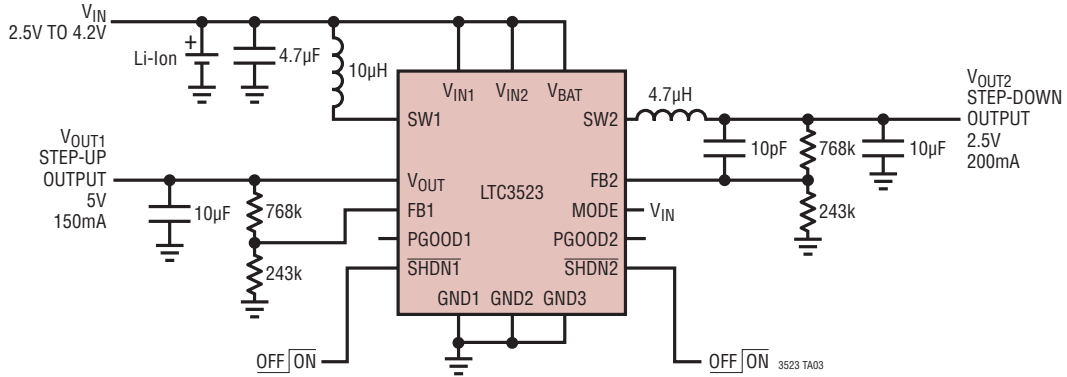

Efficiency and Power Loss vs Load Current

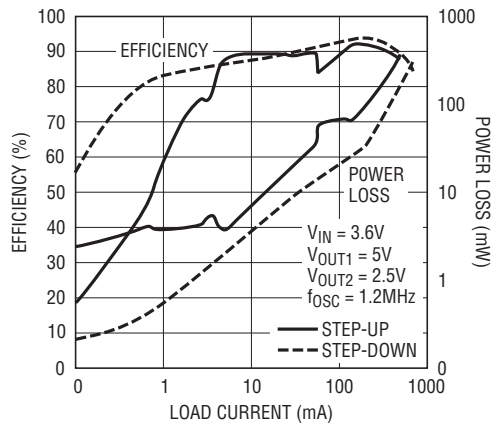

3523 TA03b

LTC3523/LTC3523-2

RELATED PARTS

PART NUMBER	DESCRIPTION	COMMENTS
LTC3400/LTC3400B	600mA (I_{SW}), 1.2MHz, Synchronous Step-Up DC/DC Converters	92% Efficiency, V_{IN} : 0.85V to 5V, $V_{OUT(MAX)}$ = 5V, I_Q = 19 μ A/300 μ A, I_{SD} < 1 μ A, ThinSOT™ Package
LTC3401	1A (I_{SW}), 3MHz, Synchronous Step-Up DC/DC Converter	97% Efficiency, V_{IN} : 0.85V to 5V, $V_{OUT(MAX)}$ = 5.5V, I_Q = 38 μ A, I_{SD} < 1 μ A, 10-Pin MS Package
LTC3402	2A (I_{SW}), 3MHz, Synchronous Step-Up DC/DC Converter	97% Efficiency, V_{IN} : 0.85V to 5V, $V_{OUT(MAX)}$ = 5.5V, I_Q = 38 μ A, I_{SD} < 1 μ A, 10-Pin MS Package
LTC3421	3A (I_{SW}), 3MHz, Synchronous Step-Up DC/DC Converter with Output Disconnect Converter	94% Efficiency, V_{IN} : 0.85V to 4.5V, $V_{OUT(MAX)}$ = 5.25V, I_Q = 12 μ A, I_{SD} < 1 μ A, 24-Pin (4mm × 4mm) QFN Package
LTC3422	1.5A (I_{SW}), 3MHz, Synchronous Step-Up DC/DC with Output Disconnect Converter	94% Efficiency, V_{IN} : 0.85V to 4.5V, $V_{OUT(MAX)}$ = 5.25V, I_Q = 25 μ A, I_{SD} < 1 μ A, 10-Pin (3mm × 3mm) DFN Package
LTC3426	2A (I_{SW}), 1.5MHz, Step-Up DC/DC Converter	92% Efficiency, V_{IN} : 1.6V to 5.5V, $V_{OUT(MAX)}$ = 5V, I_Q = 600 μ A, I_{SD} < 1 μ A, ThinSOT Package
LTC3427	500mA (I_{SW}), 1.25MHz, Synchronous Step-Up DC/DC with Output Disconnect Converter	94% Efficiency, V_{IN} : 1.8V to 5V, $V_{OUT(MAX)}$ = 5.25V, I_Q = 350 μ A, I_{SD} < 1 μ A, 6-Pin (2mm × 2mm) DFN Package
LTC3429/LTC3429B	600mA (I_{SW}), 550kHz, Synchronous Step-Up DC/DC Converters Soft-Start/Output Disconnect	96% Efficiency, V_{IN} : 0.85V to 4.3V, $V_{OUT(MAX)}$ = 5V, I_Q = 20 μ A, I_{SD} < 1 μ A, ThinSOT Package
LTC3459	80mA (I_{SW}), Synchronous Step-Up DC/DC Converter	92% Efficiency, V_{IN} : 1.5V to 5.5V, $V_{OUT(MAX)}$ = 10V, I_Q = 10 μ A, I_{SD} < 1 μ A, ThinSOT Package
LTC3525-3 LTC3525-3.3 LTC3525-5	400mA (I_{SW}), Synchronous Step-Up DC/DC Converters with Output Disconnect	94% Efficiency, V_{IN} : 0.85V to 4V, $V_{OUT(MAX)}$ = 5V, I_Q = 7 μ A, I_{SD} < 1 μ A, SC-70 Package
LTC3526/LTC3526L LTC3526B	500mA (I_{SW}), 1MHz Synchronous Step-Up DC/DC Converters with Output Disconnect	94% Efficiency, V_{IN} : 0.85V to 5V, $V_{OUT(MAX)}$ = 5.25V, I_Q = 9 μ A, I_{SD} < 1 μ A, 6-Pin (2mm × 2mm) DFN Package
LTC3528/LTC3528B	1A (I_{SW}), 1MHz Synchronous Step-Up DC/DC Converters with Output Disconnect	94% Efficiency, V_{IN} : 0.85V to 5V, $V_{OUT(MAX)}$ = 5.25V, I_Q = 10 μ A, I_{SD} < 1 μ A, 8-Pin (2mm × 3mm) DFN Package

ThinSOT is a trademark of Linear Technology Corporation.