

1.75A Synchronous Step-Down Regulator in 1.6mm × 1mm WLCSP

FEATURES

- **V_{OUT} Range: 0.5V to 3.65V**
- **2MHz Switching Frequency**
- **Low Ripple Burst Mode® or Forced Continuous Mode of Operation**
- **High Efficiency: 30mΩ NMOS, 100mΩ PMOS**
- **Peak Current Mode Control**
- **22ns Minimum On-Time**
- **Wide Bandwidth, Fast Transient Response**
- **Safely Tolerates Inductor Saturation in Overload**
- **V_{IN} Range: 2.25V to 5.5V**
- **V_{OUT} Accuracy: ±1.0%**
- **Precision 400mV Enable Threshold**
- **Low Shutdown Current (1μA)**
- **Internal Compensation**
- **Internal Soft-Start**
- **Power Good Output**
- **Tiny WLCSP Package and Few Tiny External Components Yield a Complete Solution Size of 9mm²**

APPLICATIONS

- General Purpose, Industrial, GSM Supplies
- Distributed DC Power Systems (POL)
- FPGA, ASIC, μP Core Supplies

DESCRIPTION

The LTC3306 is a very small, high efficiency, low noise, monolithic synchronous step-down DC/DC converter capable of providing as much as 1.75A average output current from a 2.25V to 5.5V input supply. Using constant frequency, peak current mode control at 2MHz switching frequency, and with a minimum on-time of 22ns, this regulator achieves fast transient response and precise regulation in an extremely small solution size.

The LTC3306 is available in forced continuous mode for lower noise, or low-ripple Burst Mode operation for higher efficiency at light load.

The LTC3306 is available with an external resistor programmable output or with fixed output voltages from 500mV to 3.65V in 50mV increments, and 100% duty cycle operation delivers very low drop out voltage.

Other features include a high precision PGOOD output, a precision enable threshold, output overvoltage protection, thermal shutdown, and output short-circuit protection. This device is available in a 6-pin 1.6mm × 1mm, 0.5mm pitch WLCSP package.

All registered trademarks and trademarks are the property of their respective owners.

TYPICAL APPLICATION

High Efficiency, 2MHz, 1.2V/1.75A Step-Down Converter

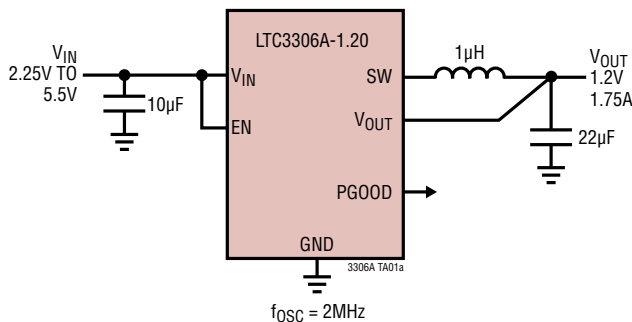

Efficiency vs Load Current

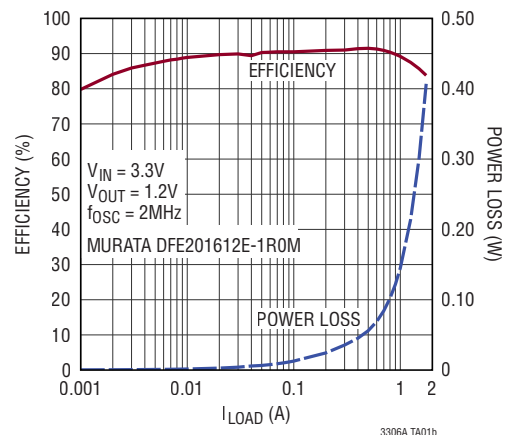

LTC3306

ABSOLUTE MAXIMUM RATINGS

(Note 1)

V_{IN}	-0.3V to 6V
EN	-0.3V to Lesser of ($V_{IN} + 0.3V$) or 6V
V_{OUT}	-0.3V to Lesser of ($V_{IN} + 0.3V$) or 6V
PGOOD.....	-0.3V to 6V
I_{PGOOD}	5mA
Operating Junction Temperature Range (Note 2):	
LTC3306AA/LTC3306CA	-40°C to +125°C
Storage Temperature Range	-65°C to +150°C

PIN CONFIGURATION

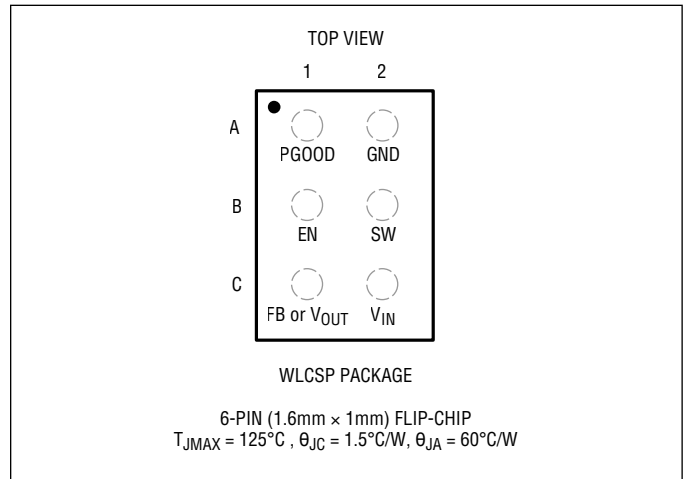

PART NUMBER CONSTRUCTION

LTC3306 OPTION	PARAMETER		FB or V_{OUT}
	SWITCHING FREQUENCY***	OPERATIONAL MODE	
A	2MHz	Discontinuous Mode (DCM)/Burst Mode	0.5V*
C	2MHz	Forced Continuous Mode (FCM)	1.2V**

*0.5V version is the adjustable version with FB pin. Connect an external resistor divider on this pin to set the output voltage.

**Other fixed output voltages from 500mV to 3.65V in 50mV increments are available; contact Marketing for availability.

***Contact Marketing regarding the availability of 6MHz versions of the above devices.

ORDER INFORMATION

DEVICE	PART MARKING	PACKAGE DESCRIPTION	TEMPERATURE RANGE
LTC3306AACBZ-R7	HRM	6-Pin (1.6mm × 1mm) WLCSP	-40°C to 125°C
LTC3306CACBZ-R7	HRP	6-Pin (1.6mm × 1mm) WLCSP	-40°C to 125°C
LTC3306AACBZ-1.2-R7	HRR	6-Pin (1.6mm × 1mm) WLCSP	-40°C to 125°C
LTC3306CACBZ-1.2-R7	HRT	6-Pin (1.6mm × 1mm) WLCSP	-40°C to 125°C

DEVICE NAME CONSTRUCTION

GENERIC	OPTION	TEMP GRADE*	PACKAGE CODE	LEAD FREE	TAPE AND REEL
LTC3306	A, C	A	CB	Z	R7 (3000)

Contact the factory for parts specified with wider operating temperature ranges. *The temperature grade is identified by a label on the shipping container.

[Tape and reel specifications.](#)

ELECTRICAL CHARACTERISTICS

The ● denotes the specifications which apply over the full operating temperature range (Note 2), otherwise specifications are at $T_A = 25^\circ\text{C}$. $V_{\text{IN}} = 4\text{V}$, $V_{\text{EN}} = V_{\text{IN}}$ unless otherwise noted.

PARAMETER	CONDITIONS		MIN	TYP	MAX	UNITS
Input Supply						
Operating Supply Voltage (V_{IN})		●	2.25		5.5	V
V_{IN} Undervoltage Lockout Hysteresis	V_{IN} Rising	●	2.0	2.1 150	2.2	V mV
V_{IN} Quiescent Current in Shutdown	$V_{\text{EN}} = 0.1\text{V}$			1	2	μA
V_{IN} Quiescent Current (Note 3)	Burst Mode Operation, Sleeping All Modes, Not Sleeping			40 1.2	60 2	μA mA
Enable Threshold Hysteresis	V_{EN} Rising	●	0.375	0.400 50	0.425	V mV
EN Pin Leakage	$V_{\text{EN}} = 0.5\text{V}$				± 20	nA
Voltage Regulation						
Regulated FB or Output Voltage (FB or V_{OUT})	% of Selected FB or V_{OUT} $0.5\text{V} \leq (\text{FB or } V_{\text{OUT}}) \leq 3.65\text{V}$	●	99	100	101	%
Feedback Voltage Line Regulation	$V_{\text{IN}} = \text{MAX}(2.25\text{V}, V_{\text{OUT}} + 150\text{mV})$ to 5.5V			0.02	0.1	%/V
Feedback Voltage Load Regulation				0.01	0.1	%/A
Minimum On-Time ($t_{\text{ON,MIN}}$)	$V_{\text{IN}} = 5.5\text{V}$	●		22	42	ns
Maximum Duty Cycle		●	100			%
Top Switch ON-Resistance				100		m Ω
Bottom Switch ON-Resistance				30		m Ω
Top Switch Current Limit (I_{PEAKMAX})			2.5	2.75	3.0	A
Bottom Switch Current Limit ($I_{\text{VALLEYMAX}}$)			2	2.3	2.6	A
Bottom Switch Reverse Current Limit (I_{REVMAX})	LTC3306C		-1.35	-0.9	-0.4	A
SW Leakage Current					± 100	nA
Power Good and Soft-Start						
PGOOD Threshold (Rising) Hysteresis	Percentage of Regulated V_{OUT}	● ●	97 0.7	98 1.2	99 1.7	% %
V_{OUT} Overvoltage Threshold (Rising) Hysteresis	Percentage of Regulated V_{OUT}	● ●	107 1	110 2.2	114 3.5	% %
PGOOD Delay				100		μs
PGOOD Pull-Down Resistance	$V_{\text{PGOOD}} = 0.1\text{V}$			10	20	Ω
PGOOD Leakage	$V_{\text{PGOOD}} = 5.5\text{V}$				20	nA
Soft-Start Duration	V_{OUT} Rising from 0V to PGOOD Threshold	●	0.25	1	3	ms
Oscillator						
Default Oscillator Frequency	LTC3306A, LTC3306C		1.9	2	2.1	MHz

Note 1: Stresses beyond those listed under Absolute Maximum Ratings may cause permanent damage to the device. Exposure to any Absolute Maximum Rating condition for extended periods may affect device reliability and lifetime.

Note 2: The LTC3306AA is tested under pulsed load conditions such that $T_J \approx T_A$. The LTC3306CA is guaranteed to meet specifications from 0°C to 85°C junction temperature. Specifications over the -40°C to 125°C operating junction temperature range are assured by design,

characterization, and correlation with statistical process controls. The LTC3306CA is guaranteed over the -40°C to 125°C operating junction temperature range.

High junction temperatures degrade operating lifetimes; operating lifetime is derated for junction temperatures above 125°C . Note that the maximum ambient temperature consistent with these specifications is determined by specific operating conditions in conjunction with board layout, the rated package thermal impedance, and other environmental factors. The junction

ELECTRICAL CHARACTERISTICS

temperature (T_J in $^{\circ}\text{C}$) is calculated from ambient temperature (T_A in $^{\circ}\text{C}$) and power dissipation (PD in Watts) according to the formula: $T_J = T_A + (PD \cdot \theta_{JA})$, where θ_{JA} (in $^{\circ}\text{C}/\text{W}$) is the package thermal impedance.

The LTC3306 includes overtemperature protection that protects the device during momentary overload conditions. Junction temperatures will exceed

150 $^{\circ}\text{C}$ when overtemperature protection is engaged. Continuous operation above the specified maximum operating junction temperature may impair device reliability.

Note 3: Supply current specification does not include switching currents. Actual supply currents will be higher.

TYPICAL PERFORMANCE CHARACTERISTICS $V_{IN} = 3.3\text{V}$, $T_A = 25^{\circ}\text{C}$, unless otherwise noted.

LTC3306C-1.2 Regulation Voltage vs Temperature

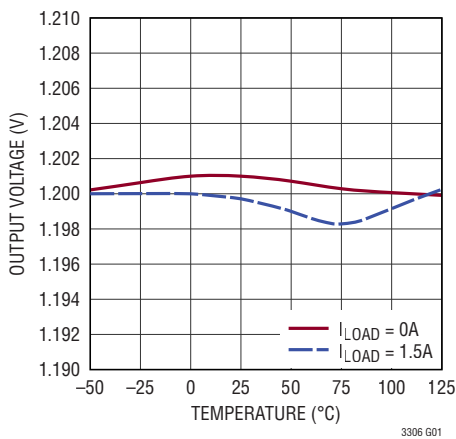

Minimum On-Time vs Input Voltage

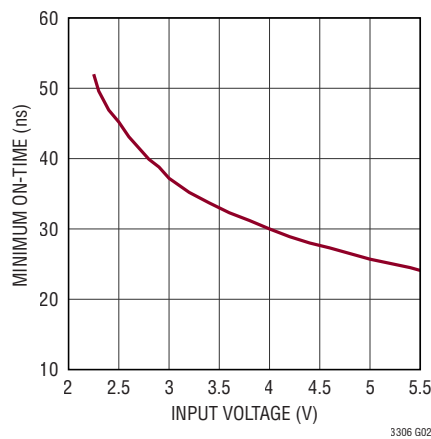

Minimum On-Time vs Temperature

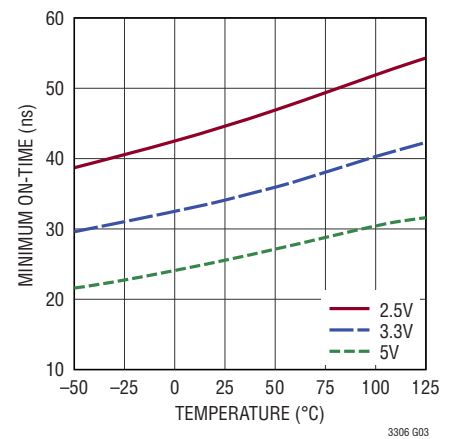

Switch On-Resistance vs Input Voltage

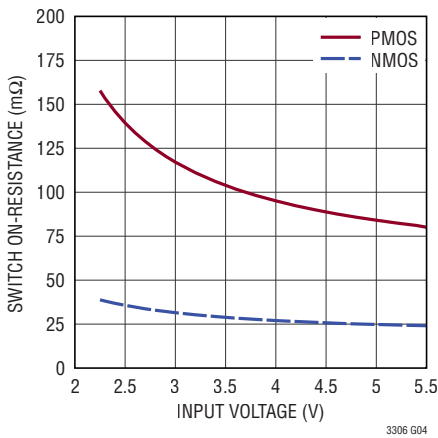

Switch On-Resistance vs Temperature

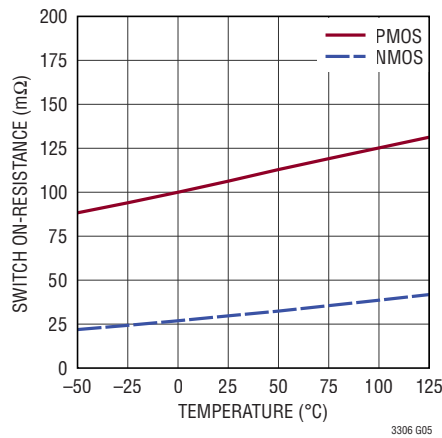

Switching Frequency vs Input Voltage

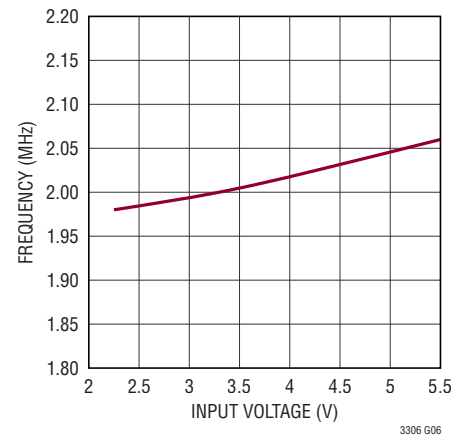

TYPICAL PERFORMANCE CHARACTERISTICS

$V_{IN} = 3.3V$, $T_A = 25^\circ C$, unless otherwise noted.

Switching Frequency vs Temperature

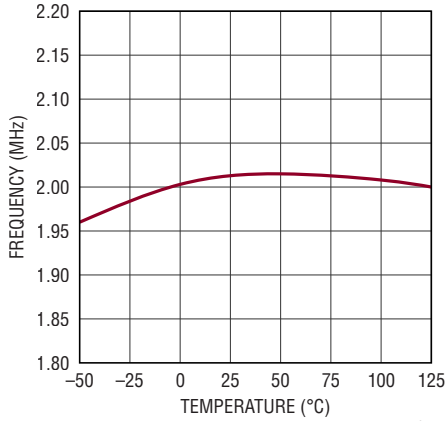

3306 G07

Switch Current Limits vs Temperature

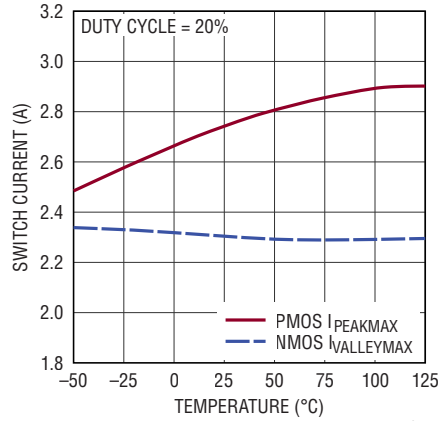

3306 G08

PMOS Current Limit vs Input Voltage

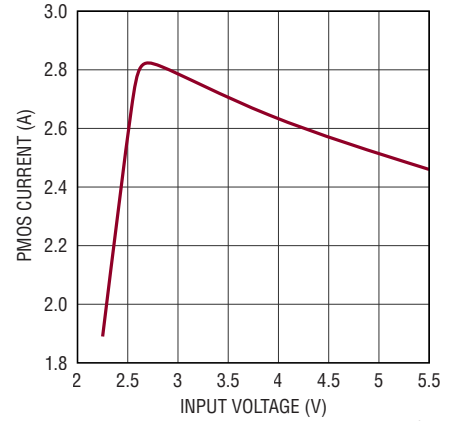

3306 G09

PMOS Current Limit vs Duty Cycle

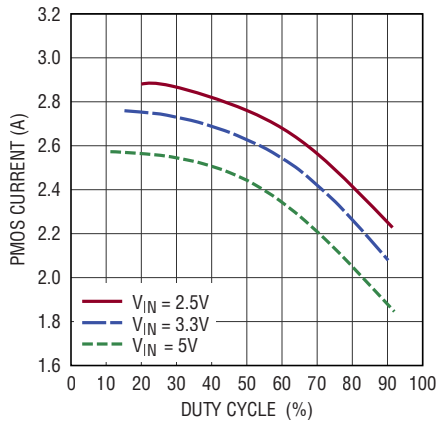

3306 G10

V_{IN} Shutdown Current vs Temperature

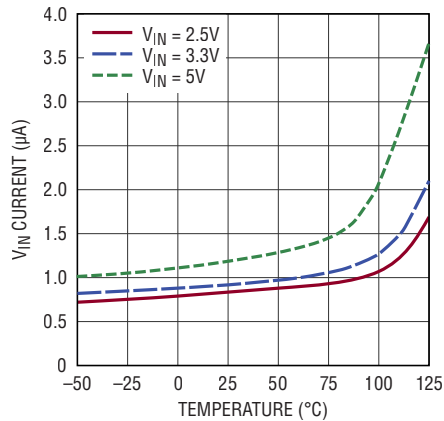

3306 G11

V_{IN} Quiescent Current, Burst Mode Operation, Sleeping vs Temperature

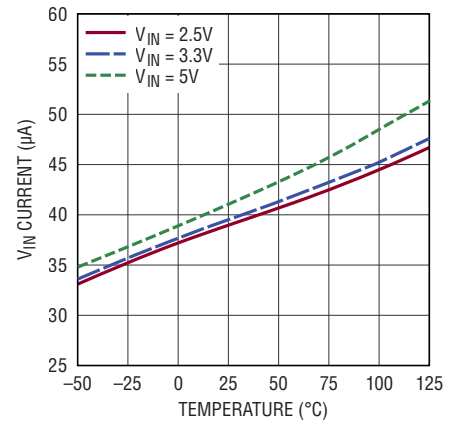

3306 G12

V_{IN} Quiescent Current All Modes, Not Sleeping vs Temperature

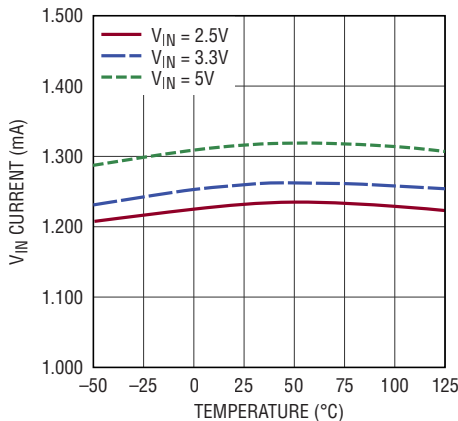

3306 G13

Switch Leakage vs Temperature

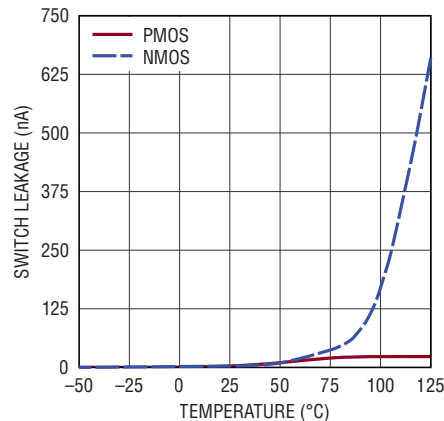

3306 G14

Enable Thresholds vs Temperature

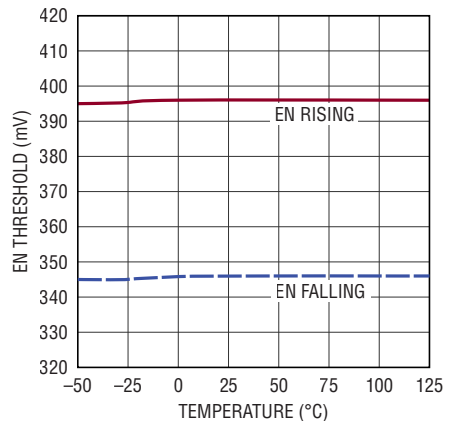

3306 G15

TYPICAL PERFORMANCE CHARACTERISTICS $V_{IN} = 3.3V$, $T_A = 25^\circ C$, unless otherwise noted.

V_{IN} UVLO Thresholds vs Temperature

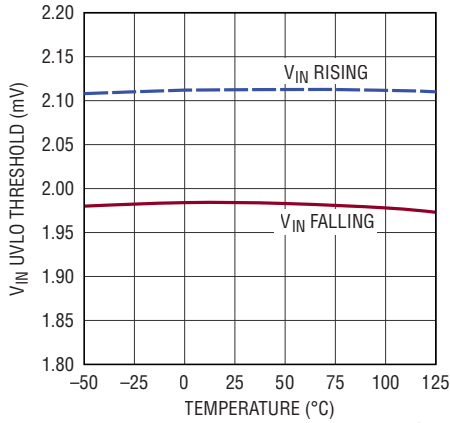

UV, OV PGOOD Thresholds vs Temperature

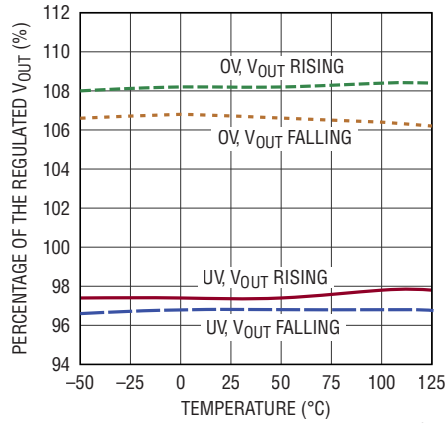

V_{OUT} Load Regulation, $V_{OUT} = 1.2V$

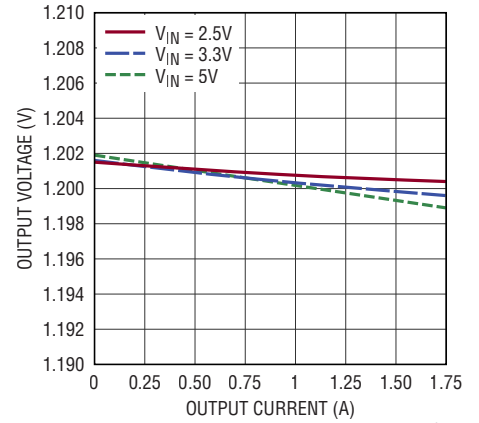

V_{OUT} Line Regulation, $V_{OUT} = 1.2V$

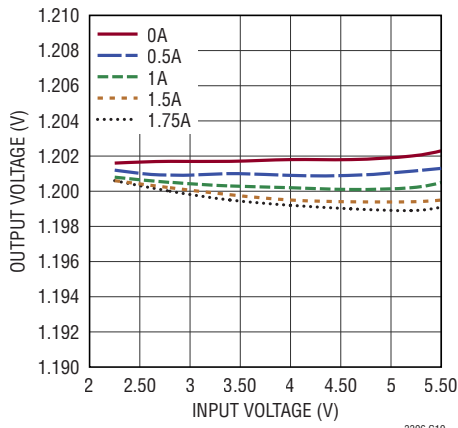

Efficiency vs Load, $V_{OUT} = 1.2V$, LTC3306A

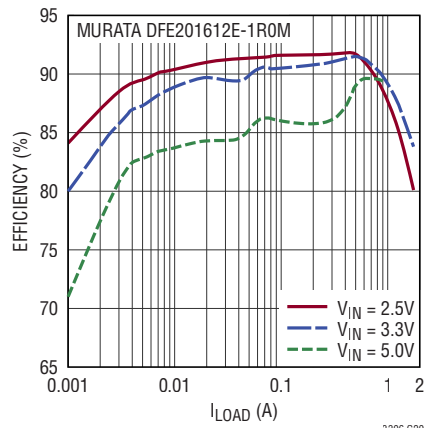

Efficiency vs Load, $V_{OUT} = 1.2V$, LTC3306C

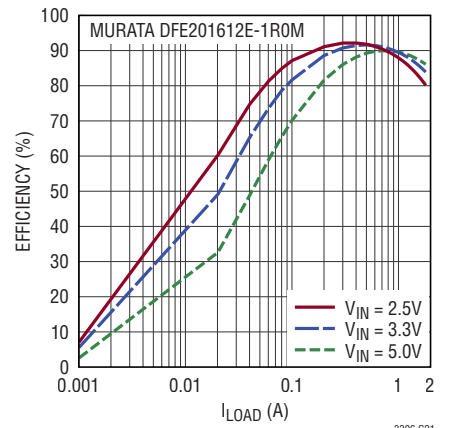

PIN FUNCTIONS

PGOOD (A1): PGOOD is the open-drain output of an internal power good comparator. When the regulated output voltage falls below the PGOOD threshold or rises above the overvoltage threshold, PGOOD is pulled low. When V_{IN} is above 2.25V and the part is in shutdown, this pin is also pulled low.

GND (A2): GND is the output voltage remote ground sense and the return path of the internal bottom side power switch. Connect the negative terminals of the input and output capacitors as close to the IC as possible.

EN (B1): EN has a precision enable threshold with hysteresis. An external resistor divider, from V_{IN} or from another supply, can be used to program the threshold below which the LTC3306 will shut down. If the precision threshold is not required, tie EN directly to V_{IN} . When the EN pin is low,

the LTC3306 enters a low current shutdown mode where all internal circuitry is disabled. Do not float this pin.

SW (B2): SW is the switching output of the internal power switches. Connect SW to the inductor with a short, wide trace.

FB (C1): FB is the output voltage feedback pin for the LTC3306 adjustable version. The FB pin is regulated to 500mV. Connect an external resistor divider on this pin to set the output voltage.

V_{OUT} (C1): V_{OUT} is the regulated output voltage pin for the LTC3306 fixed voltage versions. Connect a low-ESR capacitor from this node to GND.

V_{IN} (C2): V_{IN} supplies current to the internal circuitry and topside power switch. Connect a low-ESR capacitor from this node to GND.

BLOCK DIAGRAM

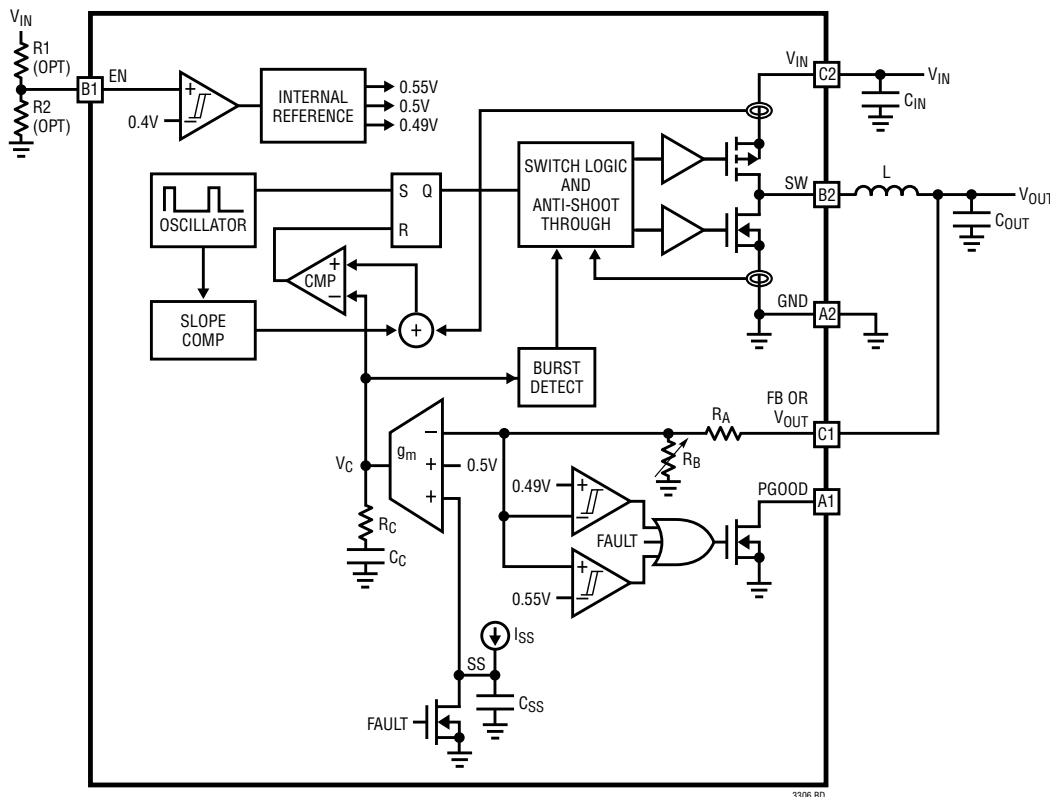

NOTES:

- FOR THE LTC3306 ADJUSTABLE VERSION, PIN C1 IS FB. FB IS HIGH IMPEDANCE AND R_B RESISTANCE IS INFINITE.
- FOR THE LTC3306 FIXED OUTPUT VOLTAGE VERSIONS, PIN C1 IS V_{OUT} . R_B IS INTERNALLY SET FOR THE REGULATION TARGET. V_{OUT} PIN IS NOT HIGH IMPEDANCE AND WILL REGULATE TO THE OUTPUT VOLTAGE TARGET.

OPERATION

Voltage Regulation

The LTC3306 is a monolithic, constant frequency, peak current mode, step-down DC/DC converter. The synchronous buck switching regulator is factory programmed and requires only input and output capacitors and an inductor for a complete solution. A factory-programmed oscillator turns on the internal top power switch at the beginning of each clock cycle. Current in the inductor then increases until the top switch current comparator trips and turns off the top power switch. The peak inductor current at which the top switch turns off is controlled by an internal control voltage (V_C). The error amplifier regulates V_C by comparing the voltage on the FB or V_{OUT} node with an internal reference. When the load current increases, it causes a reduction in the output voltage relative to the reference, leading the error amplifier to raise the V_C voltage until the average inductor current matches the new load current. When the top power switch turns off, the synchronous power switch turns on and ramps down the inductor current for the remainder of the clock cycle or, if configured for Burst Mode operation, until the inductor current falls to zero. If overload conditions result in excessive current flowing through the bottom switch, the next clock cycle will be skipped until switch current returns to a safe level.

The enable pin has a precision 400mV threshold that may be used to provide event-based power-up sequencing by connecting the EN pin to the output of another regulator through a resistor divider. If the EN pin is low, the device is shut down and in a low quiescent current state. When the EN pin is above its threshold, the switching regulator will be enabled.

The LTC3306 has forward and reverse-current limiting, short-circuit protection, output overvoltage protection, and soft-start to limit inrush current during start-up or recovery from a short-circuit.

Mode Selection

The LTC3306 is available in two operational modes: forced continuous mode, and Burst Mode operation.

In forced continuous mode, the switches turn on every cycle, maintaining regulation by allowing the inductor current to reverse at light load. This mode allows the buck

to run at a fixed frequency with a consistent amount of current ripple, generating minimal output voltage ripple.

In Burst Mode operation, reverse current is prevented on a cycle-by-cycle basis, allowing discontinuous switching operation at lower average load currents. While operating at light loads, the output voltage charges to a slightly higher voltage than its normal regulation voltage. The regulator then suspends switching and disables most of the internal circuitry, minimizing input power. The output capacitor provides required load current until the output voltage drops below its programmed value, when the circuitry is powered on and switching cycles commence.

Output Power Good

When the LTC3306 output voltage is above 98% of the regulation voltage, the output is considered good and the open-drain PGOOD pin becomes high impedance and can be pulled high using an external resistor. When the output voltage falls below 96.8%, the internal pull-down device will pull the PGOOD pin low. The PGOOD pin is also pulled low during the following fault conditions: EN pin is low, V_{IN} is too low, V_{OUT} is above 110% of the nominal voltage, or during thermal shutdown. To filter noise and short duration output voltage transients, the lower threshold has a hysteresis of 1%, the upper threshold has a hysteresis of 2%, and both have a built-in 100 μ s time delay to report a PGOOD change of state.

Output Overvoltage Protection

During an output overvoltage event, when V_{OUT} is greater than 110% of the nominal regulated voltage, the LTC3306 top power switch will be turned off. If the output remains out of regulation for more than 100 μ s, the PGOOD pin will be pulled low. An output overvoltage event should not happen under normal operating conditions.

Overtemperature Protection

To prevent thermal damage to the LTC3306 and its surrounding components, the device incorporates an overtemperature (OT) function. When the die temperature reaches 160°C (typical), the switcher is disabled until the die temperature falls to 155°C (typical).

OPERATION

Output Voltage Soft-Start

Soft-starting the output is needed to prevent current surge from the input supply and output voltage overshoot during initial start-up or after a fault condition. During soft-start, the output voltage will proportionally track an internal voltage ramp. This ramp voltage is reset if the EN pin transitions low (into shutdown), or during a fault condition, allowing for graceful fault recovery. Fault conditions that reset the soft-start ramp are V_{IN} UVLO, output short-circuit, and thermal shutdown.

Dropout Operation

As the input supply voltage approaches the output voltage, the duty cycle increases toward 100%. Further reduction of the supply voltage forces the main switch to remain on for more than one cycle, eventually reaching 100% duty cycle. The output voltage during dropout will then be determined by the input voltage minus the DC voltage drop across the internal P-channel MOSFET and the inductor.

Low Supply Operation

The LTC3306 is designed to operate down to an input supply voltage of 2.25V. One important consideration at low input supply voltages is that the $R_{DS(ON)}$ s of the internal power switches increase. Calculate the worst-case LTC3306 power dissipation and die junction temperature at the lowest applicable input voltages.

Output Short-Circuit Protection and Recovery

When the output is shorted to ground, the inductor current decays very slowly when the bottom power switch is on, because the voltage across the inductor is low. To keep the inductor current in control, a secondary limit is imposed on the valley of the inductor current. If the inductor current measured through the bottom power switch is greater than $I_{VALLEYMAX}$, the top power switch will be held off, preventing a further increase in current. Subsequent switching cycles will be skipped until the inductor current is reduced below $I_{VALLEYMAX}$.

Recovery from an output short-circuit initiates a soft-start cycle. When V_{OUT} falls below regulation, as defined by the PGOOD threshold, the V_{OUT} voltage will not be allowed to rise faster than the internal soft-start ramp.

APPLICATIONS INFORMATION

Refer to the Block Diagram for reference.

Inductor Selection and Maximum Output Current

Considerations in choosing an inductor are inductance, RMS current rating, saturation current rating, DCR, and core loss.

If the duty cycle of operation is 50% or less choose the inductor based on Equation 1.

$$L \approx \frac{V_{OUT}}{0.3 \cdot I_{MAX} \cdot f_{SW}} \cdot \left(1 - \frac{V_{OUT}}{V_{IN(MAX)}} \right) \quad (1)$$

where f_{SW} is the switching frequency and I_{MAX} is 1.75A, the maximum rated load current for the LTC3306. For operation at duty cycles higher than 50%, use Equation 2 to select the inductor.

$$L \approx \frac{V_{IN(MAX)}}{0.3 \cdot I_{MAX} \cdot 4 \cdot f_{SW}} \quad (2)$$

To avoid overheating of the inductor, choose an inductor with an RMS current rating that is greater than the maximum expected output load of the application. Overload and short-circuit conditions may need to be taken into consideration.

The saturation current rating (typically labeled I_{SAT}) of the inductor must be higher than the maximum expected load current plus half the inductor ripple current (see Equation 3).

$$I_{SAT} > I_{LOAD(MAX)} + \frac{1}{2} \Delta I_L \quad (3)$$

where $I_{LOAD(MAX)}$ is the maximum output load current for a given application and ΔI_L is the inductor ripple current calculated using Equation 4.

$$\Delta I_L = \frac{V_{OUT}}{L \cdot f_{SW}} \cdot \left(1 - \frac{V_{OUT}}{V_{IN}} \right) \quad (4)$$

A more conservative choice would be to use an inductor with an I_{SAT} rating higher than the maximum current limit of the LTC3306.

To keep the efficiency high, choose an inductor with low series resistance (DCR). The core material should be intended for high frequency applications. Table 1 shows recommended inductors from several manufacturers.

Table 1. Recommended Inductors

MANUFACTURER	FAMILY	L (nH)	MAX I _{DC} (A)	MAX DCR (mΩ)	SIZE IN mm (L × W × H)
Murata	DFE18SAN_E0	470 to 1000	2 to 3.1	64 to 144	1.6 × 0.8 × 0.8
Murata	DFE18SAN_G0	470 to 1000	2.1 to 3.3	54 to 128	1.6 × 0.8 × 1.0
Murata	DFE201210U	470 to 1000	3.1 to 4.4	42 to 95	2.0 × 1.2 × 1.0
Murata	DFE201612E	470 to 1000	4.0 to 5.5	26 to 48	2.0 × 1.6 × 1.2
TDK	TFM160808ALC	470	2.9	62	1.6 × 0.8 × 0.8
Taiyo Yuden	MCHK1608	470 to 1000	2.2 to 3.3	43 to 110	1.6 × 0.8 × 0.8
Taiyo Yuden	MCHK2012	470 to 1000	2.26 to 3.21	36 to 111	2.0 × 1.2 × 0.8
Taiyo Yuden	MCKK2012	470 to 1000	3.6 to 4.5	39 to 90	2.0 × 1.2 × 1.0
Littlefuse	LPW1608	470 to 1000	2.0 to 3.4	45 to 150	1.6 × 0.8 × 0.8
Littlefuse	LPW1201208	470 to 1000	3.4 to 5.0	35 to 65	2.0 × 1.2 × 0.8
Littlefuse	LPW1201210	470 to 1000	3.5 to 5.4	28 to 60	2.0 × 1.2 × 1.0
Würth Elektronik	74479262147	470	1.5	87	1.6 × 0.8 × 0.8

APPLICATIONS INFORMATION

Input Capacitors

Bypass the input of the LTC3306 with a ceramic capacitor close to the part from V_{IN} to GND. See Output Capacitor, Output Ripple, and Transient Response for more detail. X7R or X5R capacitors are recommended for best performance across temperature and input voltage variations. Note that larger input capacitance is required when a lower switching frequency is used. If the input power source has high impedance, or if there is significant inductance due to long wires or cables, additional bulk capacitance may be necessary. This can be provided with a low performance electrolytic capacitor.

A ceramic input capacitor combined with trace or cable inductance forms a high quality (underdamped) tank circuit. If a LTC3306 circuit is plugged into a live supply, the input voltage can ring to twice its nominal value, possibly exceeding the maximum input voltage rating. This situation is easily avoided (see [Application Note AN88](#)).

Table 2. Ceramic Capacitor Manufacturers

VENDOR	URL
Kyocera AVX	www.kyocera-avx.com
Murata	www.murata.com
TDK	www.tdk.com
Taiyo Yuden	www.t-yuden.com

Output Capacitor, Output Ripple, and Transient Response

The output capacitor has two essential functions. Along with the inductor, it filters the square wave generated by the LTC3306 to produce a DC output. In this role, it determines the output ripple, thus low impedance at the switching frequency is important. The second function is to store energy in order to satisfy transient loads and stabilize the LTC3306's control loop. The LTC3306 is internally compensated and has been designed to operate at a high bandwidth for fast transient response capability. The selection of C_{OUT} will affect the bandwidth of the system, but the transient response is also affected by V_{OUT} , V_{IN} , f_{SW} , and other factors. A good place to start is with the output capacitor shown in typical application circuits.

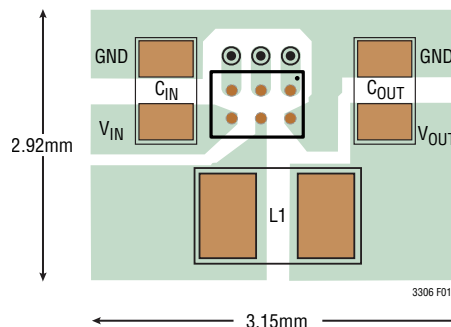

Figure 1. Recommended PCB Layout for the LTC3306

A lower value of output capacitor can be used to save space and cost, but transient performance will suffer and may cause loop instability.

Ceramic capacitors have very low equivalent series resistance (ESR) and provide the best output ripple and transient performance. Use X5R or X7R ceramic capacitors.

During a load step, the output capacitor must instantaneously supply the current to support the load until the feedback loop raises the switch current enough to support the load. The time required for the feedback loop to respond is dependent on the compensation components and the output capacitor size. Typically, 3 to 4 cycles are required to respond to a load step, but only in the first cycle does the output drop linearly. Although affected by V_{OUT} , V_{IN} , V_{SW} , $t_{ON(MIN)}$, and other factors, the output droop, V_{DROOP} , is usually about 2 to 4 times the linear droop of the first cycle (Equation 5).

$$V_{DROOP} = \frac{3 \cdot \Delta I_{OUT}}{C_{OUT} \cdot f_{SW}} \quad (5)$$

where ΔI_{OUT} is the load step.

Transient performance and control loop stability can be improved with a higher C_{OUT} . The values used in the typical application circuits are good starting points. **LTpowerCAD**® is a useful tool to help optimize C_{OUT} for a desired transient performance.

Applying a load transient and monitoring the response of the system or using a network analyzer to measure loop response are two ways to experimentally verify transient performance and control loop stability and optimize C_{OUT} .

APPLICATIONS INFORMATION

Enable Threshold Programming

The LTC3306 has a precision threshold enable pin to enable or disable the switching. When forced low, the enable pin puts the device into a low current shutdown mode.

The rising threshold of the EN comparator is 400mV, with 50mV of hysteresis. The EN pin can be tied to V_{IN} if the shutdown feature is not used. Adding a resistor divider from V_{IN} to EN programs the LTC3306 to regulate the output only when V_{IN} is above a desired voltage (see the Block Diagram). Typically, this threshold, $V_{IN(EN)}$, is used in situations where the input supply is current limited, or has a relatively high source impedance. The $V_{IN(EN)}$ threshold prevents the regulator from operating at source voltages where low input voltage problems may occur. This threshold can be adjusted by setting the values R_1 and R_2 such that they satisfy Equation 6.

$$V_{IN(EN)} = \left(\frac{R_1}{R_2} + 1 \right) \cdot 400\text{mV} \quad (6)$$

The LTC3306 will remain in shutdown until V_{IN} is above $V_{IN(EN)}$. Due to the comparator's hysteresis, switching will not stop until the input falls 12.5% below $V_{IN(EN)}$.

FB Resistor Network (LTC3306 Adjustable Version)

The output voltage of the LTC3306 adjustable version is programmed with a resistor divider between the output and the FB pin. Choose the resistor values according to Equation 7.

$$R_A = R_B \left(\frac{V_{OUT}}{500\text{mV}} - 1 \right) \quad (7)$$

as shown in Figure 2:

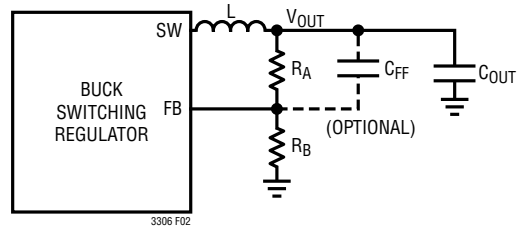
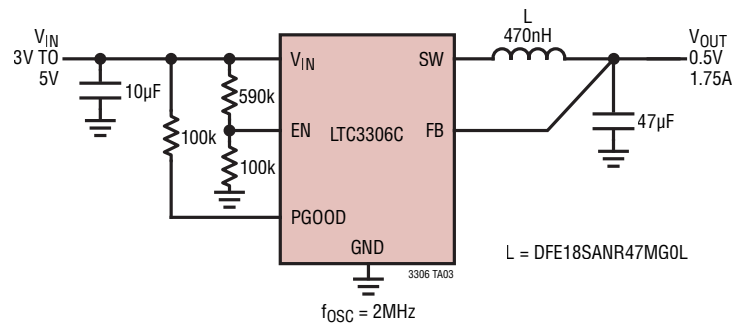

Figure 2. Feedback Resistor Network for the LTC3306 Adjustable Version

1% or 0.1% resistors are recommended to maintain output voltage accuracy. When optimizing the control loop for high bandwidth and optimal transient response, add a phase-lead capacitor connected from V_{OUT} to FB.

TYPICAL APPLICATIONS

V_{IN} UVLO at 3.0V, 2MHz, 0.5V, 1.75A, Forced Continuous Mode Step-Down Converter



2.25V to 5.5V, 2MHz, Resistor-Programmed 1V, 1.75A, Burst Mode Step-Down Converter

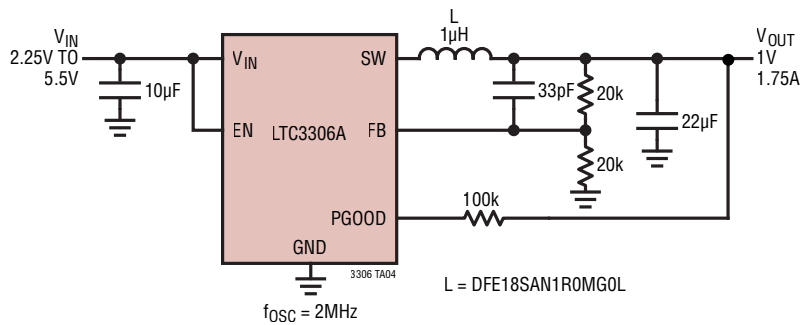

TYPICAL APPLICATIONS

V_{IN} UVLO at 4.5V, 2MHz, 1.2V, 1.75A and 3.3V, 1.75A, Forced Continuous Mode Step-Down Converters with Power-Up Sequencing

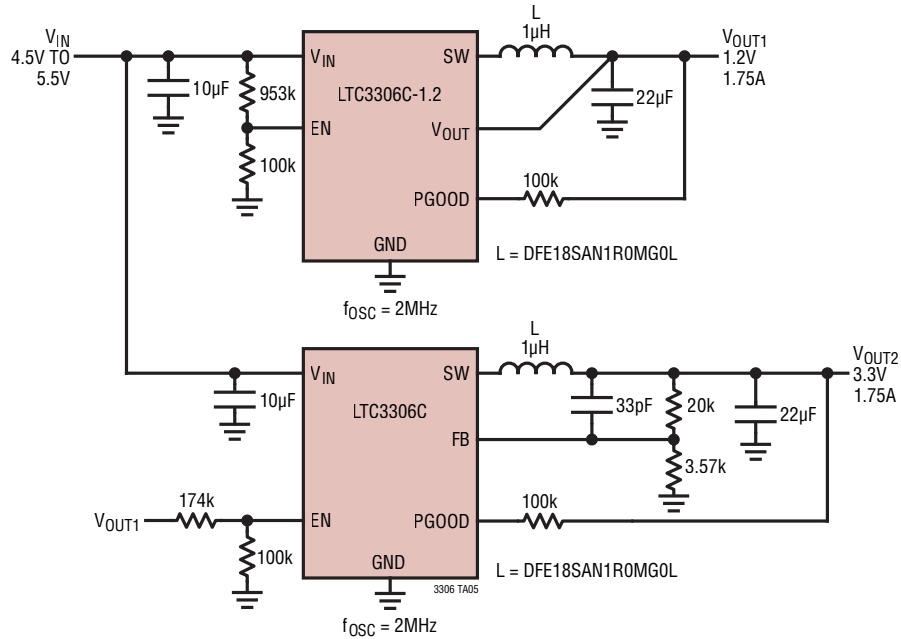

V_{IN} UVLO 2.8V, 2MHz, 1.8V, 1.75A Burst Mode Step-Down Converter Powered from Lithium-Ion Battery

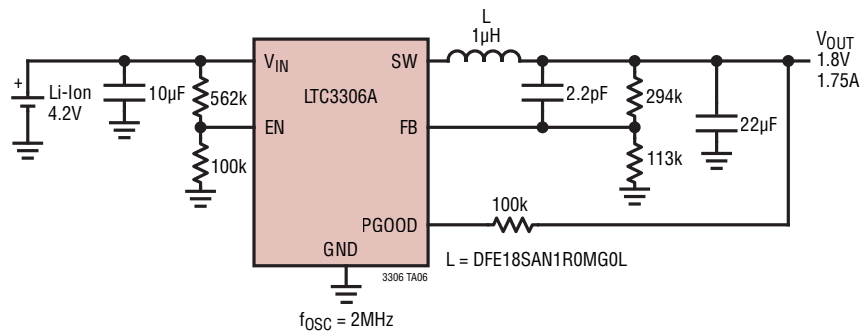

PACKAGE DESCRIPTION



6-Ball Wafer Level Chip Scale Package [WLCSP]
(CB-6-19)
Dimensions shown in millimeters

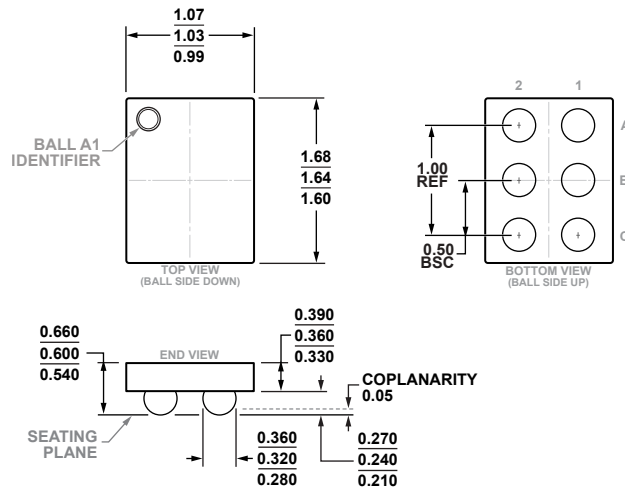

PKG-000008

09-12-2019-A

TYPICAL APPLICATION

V_{IN} UVLO at 2.25V, 2MHz, 1.2V, 1.75A, Forced Continuous Mode Step-Down Converter

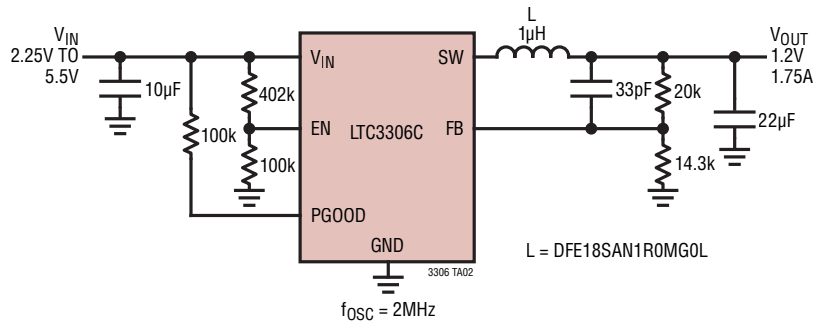

RELATED PARTS

PART NUMBER	DESCRIPTION	COMMENTS
LTC3307A/ LTC3307B	5V, 3A Synchronous Step-Down Silent Switcher	Monolithic Synchronous Step-Down DC/DC Capable of Supplying 3A at Switching Frequencies Up to 3MHz/10MHz, Silent Switcher Architecture for Ultralow EMI Emissions, 2.25V to 5.5V Input Operating Range, 0.5V to V_{IN} Output Voltage Range with $\pm 1\%$ Accuracy, PGOOD Indication, RT Programming, SYNC Input, 2mm \times 2mm LQFN
LTC3308A/ LTC3308B	5V, 4A Synchronous Step-Down Silent Switcher	Monolithic Synchronous Step-Down DC/DC Capable of Supplying 4A at Switching Frequencies Up to 3MHz/10MHz, Silent Switcher Architecture for Ultralow EMI Emissions, 2.25V to 5.5V Input Operating Range, 0.5V to V_{IN} Output Voltage Range with $\pm 1\%$ Accuracy, PGOOD Indication, RT Programming, SYNC Input, 2mm \times 2mm LQFN
LTC3309A/ LTC3309B	5V, 6A Synchronous Step-Down Silent Switcher	Monolithic Synchronous Step-Down DC/DC Capable of Supplying 6A at Switching Frequencies Up to 3MHz/10MHz, Silent Switcher Architecture for Ultralow EMI Emissions, 2.25V to 5.5V Input Operating Range, 0.5V to V_{IN} Output Voltage Range with $\pm 1\%$ Accuracy, PGOOD Indication, RT Programming, SYNC Input, 2mm \times 2mm LQFN
LTC3310S	5V, 10A Synchronous Step-Down Silent Switcher 2	Monolithic Synchronous Step-Down DC/DC Capable of Supplying 10A at Switching Frequencies Up to 5MHz, Silent Switcher Architecture for Ultralow EMI Emissions, 2.25V to 5.5V Input Operating Range, 0.5V to V_{IN} Output Voltage Range with $\pm 1\%$ Accuracy, PGOOD Indication, RT Programming, SYNC Input, Configurable for Paralleling Power Stages, 3mm \times 3mm LQFN
LTC3315A/ LTC3315B	Dual 5V, 2A Synchronous Step-Down DC/DCs	Dual Monolithic Synchronous Step-Down Voltage Regulators each Capable of Supplying 2A at Switching Frequencies up to 3MHz/10MHz, 2.25V to 5.5V Input Operating Range, 0.5V to V_{IN} Output Voltage Range with $\pm 1\%$ Accuracy, PGOOD Indication, SYNC Input, 2mm \times 2mm LQFN
LTC3370/ LTC3371	4-Channel 8A Configurable 1A Buck DC/DCs	Four Synchronous Buck Regulators with 8 \times 1A Power Stages, Can Connect Up to Four Power Stages in Parallel to Make a High Current Output (4A Maximum) with a Single Inductor, 8 Output Configurations Possible, Precision PGOOD Indication, LTC3371 Has a Watchdog Timer, LTC3370: 32-Lead 5mm \times 5mm QFN, LTC3371: 38-Lead 5mm \times 7mm QFN and TSSOP
LTC3374A	8-Channel Parallelable 1A Buck DC/DCs	Eight 1A Synchronous Buck Regulators, Can Connect Up to Four Power Stages in Parallel to Make a High Current Output (4A Maximum) with a Single Inductor, 15 Output Configurations Possible, Precision Enable inputs and PGOOD_ALL Reporting, 38-Lead 5mm \times 7mm QFN and TSSOP
LTC3375	8-Channel Parallelable 1A Buck DC/DCs	Eight 1A Synchronous Buck Regulators, Can Connect Up to Four Power Stages in Parallel to Make a High Current Output (4A Maximum) with a Single Inductor, 15 Output Configurations Possible, Precision Enable Inputs and PGOOD_ALL Reporting, I ² C Programming with a Watchdog Timer and Pushbutton, 48-Lead 7mm \times 7mm QFN
LTC3412A	3A, 4MHz, Monolithic Synchronous Step-Down Regulator	95% Efficiency, V_{IN} : 2.25V to 5.5V, $V_{OUT(MIN)} = 0.8V$, $I_Q = 64\mu A$, $I_{SD} < 1\mu A$, 4mm \times 4mm QFN-16 Package
LTC3616	5.5V, 6A, 4MHz, Synchronous Step-Down DC/DC Converter	95% Efficiency, V_{IN} : 2.25V to 5.5V, $V_{OUT(MIN)} = 0.6V$, $I_Q = 75\mu A$, $I_{SD} < 1\mu A$, 3mm \times 5mm QFN-24 Package