

# LTC3375EUK

## 8-Channel Programmable, Parallelable, 1A Buck DC/DCs

### DESCRIPTION

Demonstration circuit 1921A is a digitally programmable 8-output power supply with a pushbutton controller and watchdog timer, featuring the [LTC<sup>®</sup>3375](#). The LTC3375 has eight synchronous buck regulators, each with an independent  $V_{IN}$  supply. The buck regulators may be paralleled together to create a higher power buck regulator with a single inductor. The input range of the LTC3375 is ideal for single cell Li-Ion/Polymer battery applications.

The switching regulator settings, such as enables, feedback voltages, operating modes, phasing and other functions, can be controlled via I<sup>2</sup>C. The buck regulators can also be enabled via external precision threshold enable pins to allow hardwired power-up sequences.

The LTC3375 has a default operating frequency of 2MHz, or can be set between 1MHz to 3MHz using an external resistor. The LTC3375 also has a SYNC pin which allows the internal oscillator to synchronize to an external clock from 1MHz to 3MHz.

Refer to the LTC3375 data sheet for more details on the electrical and timing specifications.

**Design files for this circuit board are available at <http://www.linear.com/demo>**

LT, LT, LTC, LTM, Linear Technology and the Linear logo are registered trademarks and QuikEval is a trademark of Linear Technology Corporation. All other trademarks are the property of their respective owners.

### PERFORMANCE SUMMARY Specifications are at $T_A = 25^\circ\text{C}$

PARAMETER	CONDITIONS	MIN	TYP	MAX	UNITS
Input Supply Range (VIN1 to VIN8)		2.25		5.5	V
HV <sub>IN</sub> Operating Voltage		6		40	V
V <sub>CC</sub>	0mA to 0.5mA (HV <sub>IN</sub> > 7V)		3.3		V
V <sub>OUT1</sub>	0A to 1A		3.3		V
V <sub>OUT2</sub>	0A to 1A		3		V
V <sub>OUT3</sub>	0A to 1A		2.5		V
V <sub>OUT4</sub>	0A to 1A		2		V
V <sub>OUT5</sub>	0A to 1A		1.8		V
V <sub>OUT6</sub>	0A to 1A		1.5		V
V <sub>OUT7</sub>	0A to 1A		1.2		V
V <sub>OUT8</sub>	0A to 1A		1		V

## QUICK START PROCEDURE

Demo Circuit 1921A utilizes the DC590B USB to I<sup>2</sup>C interface board to control the switching regulators functions, to program the PGOOD and UVLO warnings, and to read the contents of the command and status registers.

The DC1921A is easy to set up to evaluate the performance of the LTC3375. Refer to Figure 1 and Figure 2 for proper measurement equipment setup, and follow the evaluation procedure below using the DC590B board.

NOTE: When measuring the input or output voltage ripple, care must be taken to avoid a long ground lead on the oscilloscope probe. Measure the input or output voltage ripple by touching the probe tip directly across the V<sub>IN</sub> or V<sub>OUT</sub> and GND terminals. See Figure 2 for the proper scope probe technique.

1. Refer to the DC590B Quick Start Guide for QuikEval™ setup and software installation details.
2. Set the VCCIO jumper, JP6, on the DC590B board to the 3.3V position.
3. Make sure the USB cable is connected between the computer and the DC590B controller board.
4. Set the JP1-JP8 jumpers on the DC1921A board to the OFF position.
5. Set JP9 to the SCL position to observe how the watchdog timer operates using SCL when the program is running.
6. Set JP10 to the +12V position to power HV<sub>IN</sub> from the DC590B board.
7. Set JP12 to the DC590 position to operate  $\overline{\text{KILL}}$  from software or to EXT to operate  $\overline{\text{KILL}}$  from hardware.  
  
NOTE: If JP12 is in the DC590 position and the LTC3375 GUI is not running, or the DC590 is not plugged in, then the  $\overline{\text{KILL}}$  pin will be low, preventing the regulators from enabling.
8. Connect the DC1921A to the DC590B USB serial controller using the supplied 14-conductor ribbon cable, as shown in Figure 1.
9. With the power off, connect a 0V to 6V, 3A power supply to each V<sub>IN</sub> and GND with a series ammeter and a voltmeter, as shown in Figure 1. A single 0V to 6V, 10A supply can be used instead to supply all V<sub>IN</sub> inputs simultaneously.
10. Turn on and set the VIN1 input power supply to 5V. The DC590B board gets its power from the USB cable.  
  
NOTE: Make sure that the input voltage does not exceed 6V.
11. Start the Linear Technology QuikEval program. This program should automatically detect the presence of the LTC3375 demo board (DC1921A) and activate the appropriate GUI, as seen in Figure 3.
12. On the LTC3375 control window, select the *Buck1 Enabled/Disabled* button. Enabled is displayed, and the button background color changes to yellow, but the Buck1 regulator is not yet enabled. The Buck1 Write text box indicates the new value to be written to the register, and the background color of the Write and Read text boxes turn yellow indicating that the controls have changed, but the part has not been written to or read from.
13. On the LTC3375 control window, select the *Write without Stop* button on the LTC3375 control window. The Buck1 register is updated via the I<sup>2</sup>C, but the Buck1 regulator has not yet been enabled. The Write text box background color changes to orange, indicating that the Buck1 holding register has been updated, but a stop bit was not received. The data in the command registers will not be latched or acted upon until a stop bit is received.
14. On the LTC3375 control window, select the *Read Selected* button. The Buck1 Read text box is updated with the data in the Buck1 command register.
15. On the LTC3375 control window, select the *Write with Stop* button. A stop bit is sent latching the Buck1 data and enabling the regulator. If the status register's *Auto Read Enabled* button is selected, then PG1 HI is displayed in the PG1 bit in the status register indicators.  
  
NOTE: If an  $\overline{\text{IRQ}}$  fault was latched in the PGOOD or UVLO status registers, then the *Clear Interrupt* button on the LTC3375 control window needs to be selected in order to update the status registers.
16. With the power off, connect a 0V to 3A load to each V<sub>OUT</sub> and GND with a series ammeter and a voltmeter, as shown in Figure 1.

QUICK START PROCEDURE

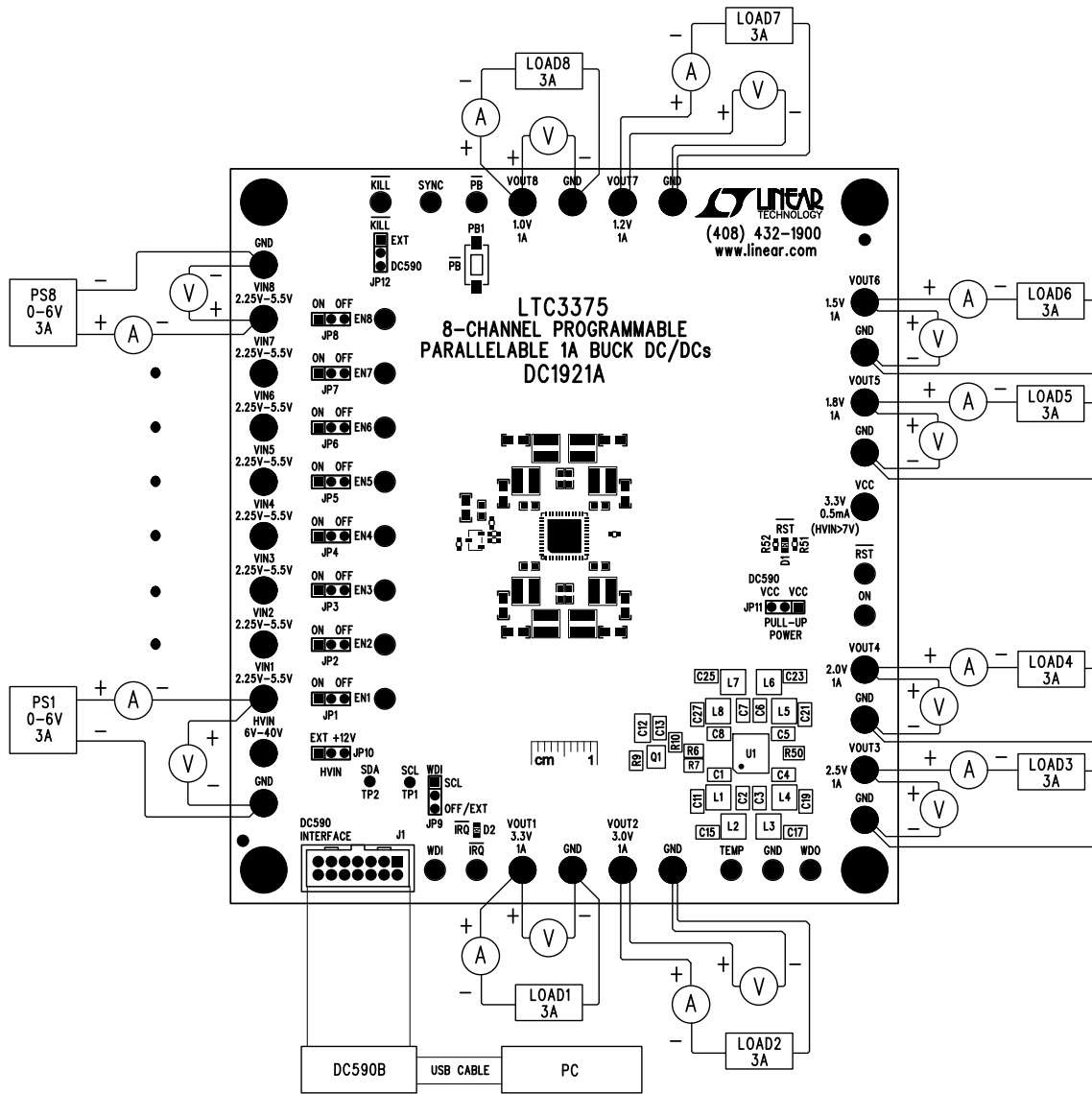

Figure 1. Proper Measurement Equipment Setup

17. Slowly increase the load from 0A to 1A and observe the output voltage. The output ripple may also be observed using an oscilloscope with the probe connected, as shown in Figure 2.
18. On the LTC3375 control window, select the *Reset All* button and observe that HI is displayed on the button. Then select the *Write with Stop* button and observe that LO is displayed on the button and Buck1 shuts off. The *Enable* button on the LTC3375 control window still displays Enabled. The Reset All bit clears the

Enable bits in the registers, clears itself and disables any pin-enabled regulator for 1 second.

19. On the DC1921A, set JP1 to the ON position and observe that Buck 1 turns on.

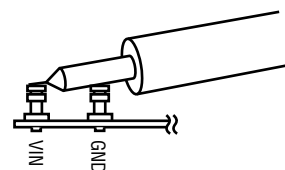

Figure 2. Measuring Input or Output Ripple

## QUICK START PROCEDURE

20. On the LTC3375 control window, select the *Enable USE/IGNORE* button and then select the *Write with Stop* button. Observe that IGNORE is displayed on the *USE/IGNORE* button and Buck1 turns off.
21. Select the *Update All* button on the LTC3375 control window and observe that Buck1 turns on.
22. Momentarily short VOUT1 to ground with a clip lead. Observe that the  $\overline{RST}$  LED, D13, on the demo board illuminates, and that the PG1 indicators display LO after a small delay. The LED shuts off and PG1 displays HI when the short is removed.  
  
NOTE: The delay in changing the status indicators on the LTC3375 control window is caused by the polling intervals between reading the status indicators.
23. Select the  $\overline{RST}$  Mask PG1 button, then select the *Write with Stop* button. The  $\overline{RST}$  Mask PG1 button changes from HI to LO.
24. Momentarily short VOUT1 to ground with a clip lead and observe that the  $\overline{RST}$  LED remains off, but the status PG1 indicator displays PG1 LO while VOUT1 is shorted.
25. Select the  $\overline{IRQ}$  Mask PG1 button and then select the *Write with Stop* button on the LTC3375 control window. The  $\overline{IRQ}$  Mask PG1 button changes from LO to HI.
26. Momentarily short VOUT1 to ground with a clip lead and observe that the  $\overline{IRQ}$  LED on the demo board illuminates and the status PG1 indicator displays PG1 LO after the short is removed.
27. Select the *Clear Interrupt* button on the LTC3375 control window and observe the  $\overline{IRQ}$  LED extinguishes and the PGOOD fault is cleared.
28. Depress and hold the  $\overline{PB}$  pushbutton for less than 10 seconds. Observe that the voltage on the ON terminal goes high and the  $\overline{IRQ}$  LED illuminates while the button is depressed.
29. Depress and hold the  $\overline{PB}$  pushbutton for more than 10 seconds until the voltage on the ON terminal goes low. Observe that the  $\overline{IRQ}$  LED stays illuminated.  
  
NOTE: Holding the  $\overline{PB}$  pushbutton depressed for greater than 10 seconds creates a hard reset. The *Clear Interrupt* button on the LTC3375 control window will need to be selected to clear the interrupt.
30. Change the EN1 jumper, JP1, from the ON to the OFF position and make sure the  $\overline{KILL}$  jumper, JP12, is in the DC590 position.
31. On the LTC3375 control window, select the  $\overline{KILL}$  HI/LO button.  $\overline{KILL}$  LO is displayed on the button and VOUT1 shuts down.
32. Refer to the Using the LTC3375 Software section for more information on how to control the device using the LTC3375 control window.
33. Refer to the LTC3375 data sheet for more details on how the LTC3375 operates.
34. When done, turn off all loads and power supplies and close the LTC3375 control window.

## USING THE LTC3375 SOFTWARE

The LTC3375 program provides control of the operating mode, switch node slew rate, phasing and reference voltage of the buck regulators. It also allows the user to monitor the contents of the PGOOD and UVLO status registers. Refer to Figure 3 for an illustration of the LTC3375 control window.

**VIEW LTC3375 PRODUCT PAGE** button opens an Internet browser and searches the Linear Technology Corporation website for information on the LTC3375 when an Internet connection is available.

**Reset All** button controls the RESET\_ALL bit in the global register. The RESET\_ALL bit is a self clearing bit that will clear the enable bits of all regulators shutting them down. It will also shutdown all pin-enabled regulators for one second and reset the pushbutton to the powered-down state.

**Enables USE/IGNORE** button controls the IGNORE\_EN bit in the global register. When this button is in the USE state, the IGNORE\_EN bit is low and each regulator can be

enabled via the EN pins. When this button is in the IGNORE state, the IGNORE\_EN is high and the enable pin for each regulator will be ignored. Each regulator will need to be enabled via I<sup>2</sup>C when in the ignore state.

**Temp Warning** option buttons control the DT bits in the global register. The DT bits adjust the die temperature warning threshold to 110°C, 125°C, 140°C or no warning (None). The DT warning causes the  $\overline{\text{IRQ}}$  pin to pull low and latches the DT\_WARN bit in the temp monitor register.

**1k Pull-Down** button controls the 1KPD bit in the global register. When this button is in the OFF state, the 1KPD bit is low and the SW nodes of all of the disabled regulators are high impedance. When this button is in the ON state, the 1KPD bit is high, and the SW nodes of all of the disabled regulators have 1kΩ impedance to ground.

**Edge** button controls the slow edge bit in the global register. When this button is in the FAST state, the slow edge bit is low and all of the regulators slew at a higher switch rate than when the bit is in the high, SLOW state.

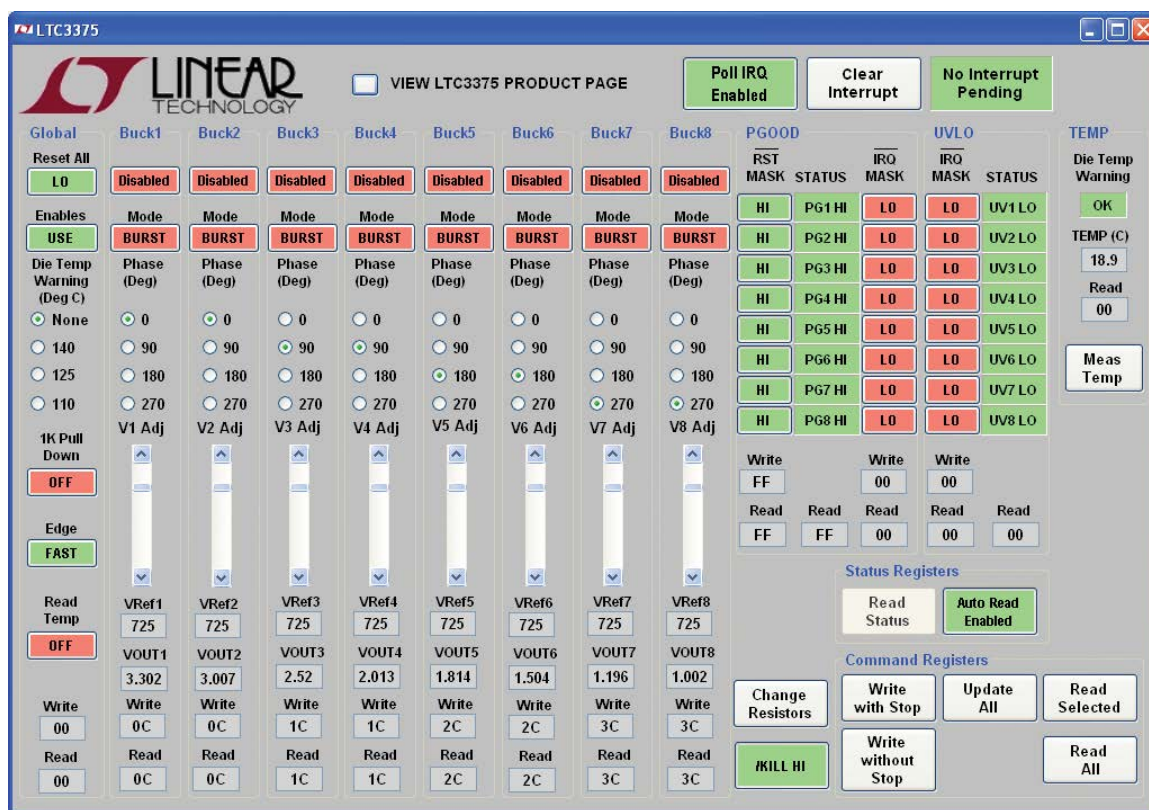

Figure 3. LTC3375 Control Window



## USING THE LTC3375 SOFTWARE

**Read Temp On/Off** button controls the RD\_TEMP bit in the global register. When this button is in the ON state, the RD\_TEMP bit is high and commands the temperature A/D to sample the voltage on the TEMP pin. This bit clears itself when done.

**Write** text box windows display the hexadecimal value that will be, or has been, written to the associated command register when the *Write without Stop* or *Write with Stop* button is selected.

**Read** text box windows display the hexadecimal value that was last read from the LTC3375 status register.

**Buck1-Buck8 Enabled/Disabled** buttons control the enable bit for each of the switching regulator registers.

NOTE: The *Write with Stop* button needs to be selected in order to write to and update the LTC3375 demo board.

**Buck1-Buck8 Phase** option buttons control the phase relationship from the oscillator to the SW node in 0°, 90°, 180° and 270° phase shifts.

**Buck1-Buck8 V Adj** sliders control the DAC bits which adjust the feedback reference from 0.425V to 0.8V in 25mV increments for the associated regulator. When any of these sliders are changed, the associated VOUT and VRef text boxes are also updated.

**VRef1-VRef8** text box windows display the feedback reference voltages of the associated switching regulator.

**VOUT1-VOUT8** text box windows display the calculated output voltages of the associated switching regulator based on the selected resistor divider network. See the *Change Resistors* button for more details.

**RST Mask PG1-PG8** buttons control the PGOOD bits in the RST Mask register. When a PGOOD bit is HI, an associated PG fault will cause the RST pin to pull low.

**IRQ Mask PG1-PG8** buttons control the PGOOD bits in the IRQ Mask register. When a PGOOD bit is HI, an associated PGOOD fault will cause the IRQ pin to pull low and will latch the fault in the PGOOD status register.

NOTE: When the status register is latched, the interrupt must be cleared using the *Clear Interrupt* button in order to allow a new fault to be latched.

**PG STATUS** indicators display the PGOOD status for each regulator. If the status register's *Auto Read Enabled* button is selected, the contents of this register will be periodically updated, otherwise the *Read Status* button will need to be selected.

**UVLO STATUS** indicators display the UVLO warnings for each VIN. If the status register's *Auto Read Enabled* button is selected, the contents of this register will be periodically updated, otherwise the *Read Status* button will need to be selected.

**Die Temperature Warning** indicator displays when the die temperature exceeds the die temperature warning threshold.

NOTE: When a die temperature fault occurs, the fault must be cleared using the *Clear Interrupt* button in order to allow a new fault to be latched.

**Temp** textbox displays the calculated die temperature in °C last read from the temperature A/D. The temperature reading is updated after the internal A/D has been polled using the RD\_Temp bit in the global register. If the status register's *Auto Read Enabled* button is selected, the temperature monitor register will be periodically read, otherwise the *Meas Temp* button will need to be selected.

**Poll IRQ Enabled/Disabled** button allows the program to poll the IRQ pin when enabled.

**Clear Interrupt** button clears any IRQ faults by writing the subaddress 0x0F and then reads back the status registers.

**Interrupt Pending** displays when an interrupt has been detected.

**Auto Read Enabled/Disabled** button is used to automatically update the status register periodically when enabled. When disabled the status registers may be updated by selecting the *Read Status* button.

**Read Status** button is used to update the status and temperature register.

**Meas Temp** button sets the RD\_TEMP bit in the global register, then reads the temp monitor A/D.

NOTE: At least one buck needs to be active in order for the temp monitor A/D to sample the temp monitor voltage and perform a conversion.

## USING THE LTC3375 SOFTWARE

**Write with Stop** button is used to write to all of the selected command registers followed by a stop bit. The stop bit will latch the data in the command registers and cause the LTC3375 to act upon the new commands. A Write text box with a white background color is not selected.

**Write without Stop** button is used to write to all of the selected command registers without sending a stop bit. This will allow the user to read back the contents of the command register prior to sending a stop bit and causing the LTC3375 to take action on the new commands. A selected register to write will be displayed by the color of the Write text box on the control window. A Write text box with a white background color is not selected.

**Update All** button is used to update all of the LTC3375 command registers to the current LTC3375 control window configuration.

**Read Selected** button is used to read all of the selected command registers. A selected register to read will be distinguished by the color of the Read text box on the control window. A Read text box with a white background color is not selected.

**Read All** button is used to read all of the command registers.

**Change Resistors** button opens up a pop-up window, as shown in Figure 4, with eight tabs allowing the user to change the resistor divider network or for each switching regulator. The resistor values will be used to calculate the values displayed in the VOUT1-VOUT8 text boxes on the LTC3375 control window. The tabs for Buck2 through Buck8 have a slave check box to allow the user to indicate when a regulator is used as a slave. These values are stored in a file when the LTC3375 program is closed so the user will not have to enter the new values each time the program is run.

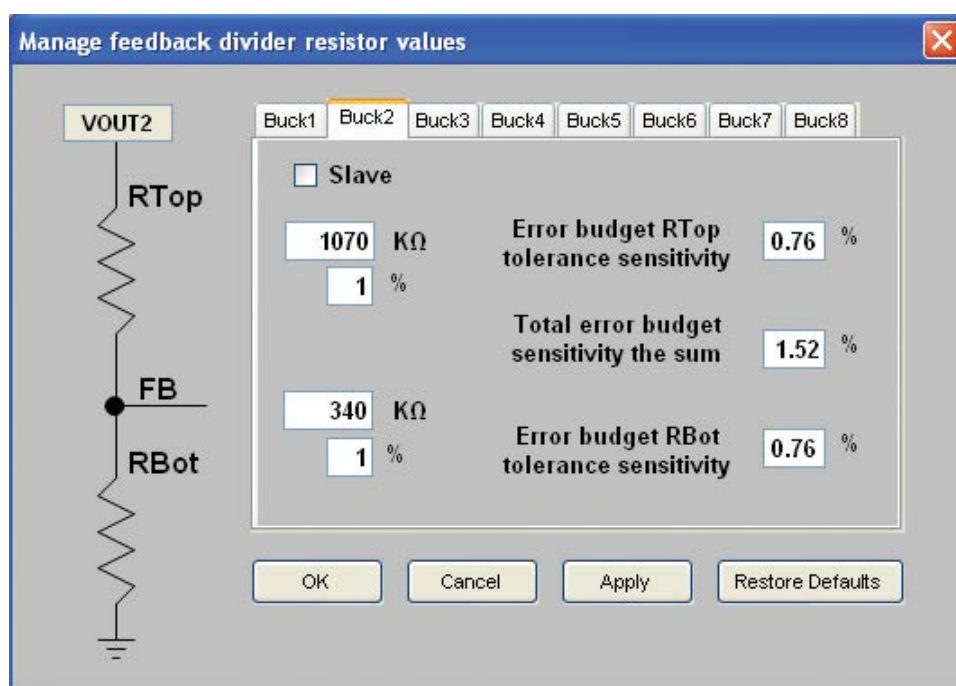

Figure 4. Change Resistor Divider Networks Window

## COMBINING BUCK REGULATORS WITH MULTIPLE OUTPUT FILTERS

The LTC3375 has the ability to combine up to four consecutively numbered bucks to achieve output currents of 1A, 2A, 3A or 4A. The easiest way to configure the DC1921A with combined outputs is to use an output inductor and output capacitor on each switch node. While combining stages with multiple filters is not ideal for performance or minimization of components, it does provide the easiest way to prototype with the desired current levels. Use the following steps to make an output a slave to the adjacent regulator:

1. Remove the desired slave regulator's associated FB resistors and feedforward capacitor.
2. Add the associated 0Ω resistor to tie the FB pin to its VIN pin.
3. Connect the outputs together at the output capacitors.
4. Connect the VIN of the slave regulator to the VIN of the master regulator.

For example, to make regulator 2 a slave of regulator 1:

1. Remove R17, R18 and C14.
2. Add a 0Ω resistor to R64.
3. Connect VIN1 to VIN2 at the VIN terminals and VOUT1 to VOUT2 at the output capacitors C11 and C15. Regulator 3 can also be combined to the regulator 1 and regulator 2 combination to create a 3A output by removing the FB3 components, R22, R25 and C16.
4. Solder a 0Ω resistor to R63.
5. Lastly, connect VOUT3 to VOUT2 and VOUT1 at the output capacitors, and VIN3 to VIN2 and VIN1 at the VIN terminals. Regulator 4 can also be added to this combination by following the same steps with regulator 4's associated components.

The higher number regulator is always a slave to the adjacent lower number regulator, therefore, regulator 1 can never be a slave and regulator 8 can never be a master.

## COMBINING BUCK REGULATORS WITH A SINGLE OUTPUT FILTER

In most applications it is more practical to use a single output filter on a combined regulator. To do this, the switch nodes of the combined regulators need to be shorted together, and the output inductor and capacitor need to be sized correctly. Please refer to the Combined Buck Regulator section in the LTC3375 data sheet for more information on sizing the output capacitor and inductor.

NOTE: The DC1921A layout was optimized for eight 1A outputs. For applications with combined regulators, the

layout should be optimized for the components used, the lowest and equal impedance on the combined switch nodes and the shortest possible AC current paths.

To combine regulators 1 and 2 for a 2A output, perform the following steps and refer to Figure 1:

1. Remove L2, R17, R18 and C14.
2. Add a 0Ω resistor to R64.

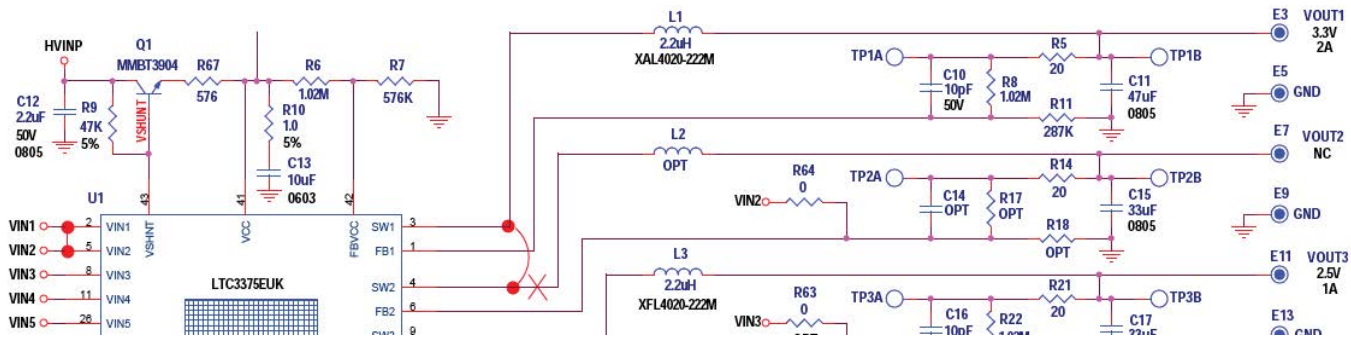

Figure 5. Combined 2A Output, Regulators 1 and 2



## COMBINING BUCK REGULATORS WITH A SINGLE OUTPUT FILTER

3. Replace L1 with an inductor that can handle the 2A output at current limit.
4. Replace C11 with at least a 47 $\mu$ F ceramic capacitor.
5. Short SW1 and SW2 together. To reduce the impedance on the SW node, cut the excess trace from SW2 to L2 close to the short as possible.
6. Short VIN1 and VIN2 together near the VIN terminals.

To combine regulators 2, 3 and 4 for a 3A output, perform the following steps and refer to Figure 6:

1. Remove L2, L3 and L4.
2. Add copper foil between the L2 and L3 pads. Refer to Figure 7 for steps 2 through 5.

NOTE: Copper foil does not provide as low a thermal or electrical impedance as PCB copper traces. An optimized

layout should be fabricated to accurately evaluate a 3A output.

3. Add copper foil between the VOUT2 and VOUT3 nodes at the location needed for the  $V_{OUT}$  side of the inductor pad. The solder mask may need to be scraped away to do this.
4. Short SW3 and SW4 together.
5. Cut the excess SW4 node between the short and L4.
6. Remove R22, R25, R29, R30, C22 and C29.
7. Add 0 $\Omega$  resistors to R62 and R63.
8. C15 and C17 must have at least 33 $\mu$ F ceramic capacitors.
9. Connect VIN2, VIN3 and VIN4 together at the VIN terminals.

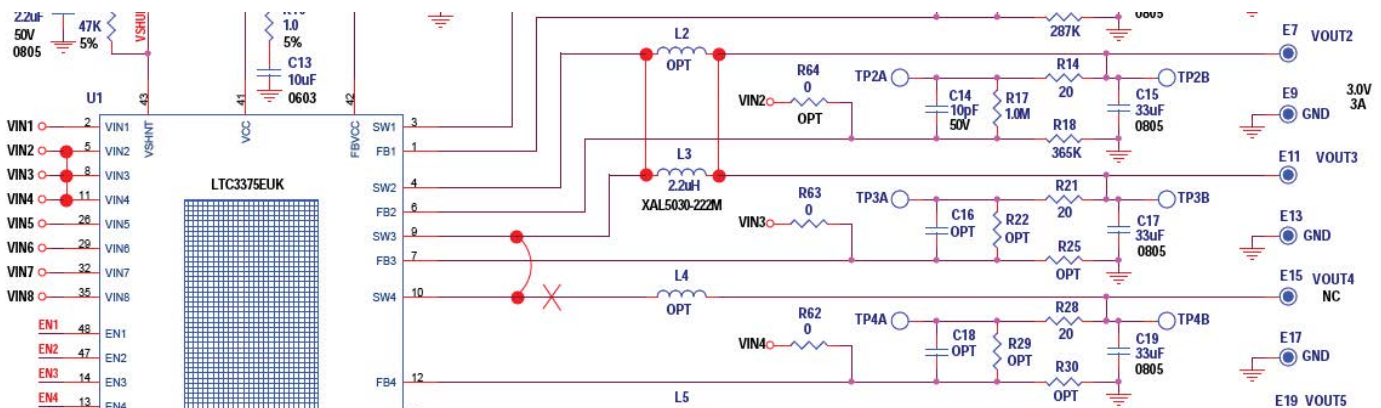

Figure 6. Combined 3A Output, Regulators 2, 3, 4

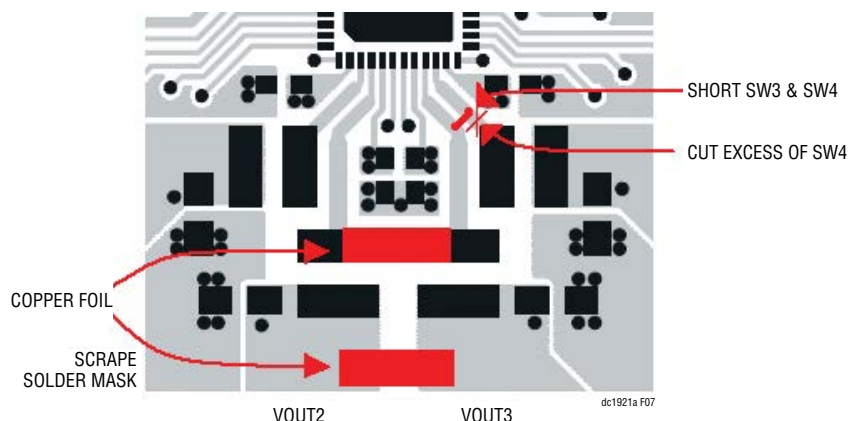

Figure 7. Copper Foil Between L2 and L3; Modified SW4 Trace

## COMBINING BUCK REGULATORS WITH A SINGLE OUTPUT FILTER

To combine regulators 1, 2, 3 and 4 for a 4A output, perform the following steps and refer to Figure 8:

1. Remove L1, L2, L3 and L4.
2. Add copper foil between the L2 and L3 pads. Refer to Figure 7 and Figure 9 for steps 2 through 5.  
  
NOTE: Copper foil does not provide as low a thermal or electrical impedance as PCB copper traces. An optimized layout should be fabricated to accurately evaluate a 4A output.
3. Add copper foil between the VOUT2 and VOUT3 nodes at the location needed for the V<sub>OUT</sub> side of the inductor pad. The solder mask may need to be scraped away to do this.
4. Short SW1 and SW2 together, then short SW3 and SW4 together.

5. Cut the excess SW1 node between the short and L1, then cut the excess SW4 node between the short and L4.
6. Remove R17, R18, R22, R25, R29, R30, C14, C22 and C29.
7. Add 0Ω resistors to R62, R63 and R64.
8. Replace C15 and C17 with at least 47μF ceramic capacitors.
9. Connect TP1B with TP2B with a 26AWG wire. This connects the 4A output voltage to the FB1 network.  
  
NOTE: Do not connect the load on the VOUT1 terminal. The 4A output will be observed on the VOUT1 terminal, however, it is only connected via the 26AWG wire and 10mil FB traces.
10. Connect VIN1, VIN2, VIN3 and VIN4 together at the VIN terminals.

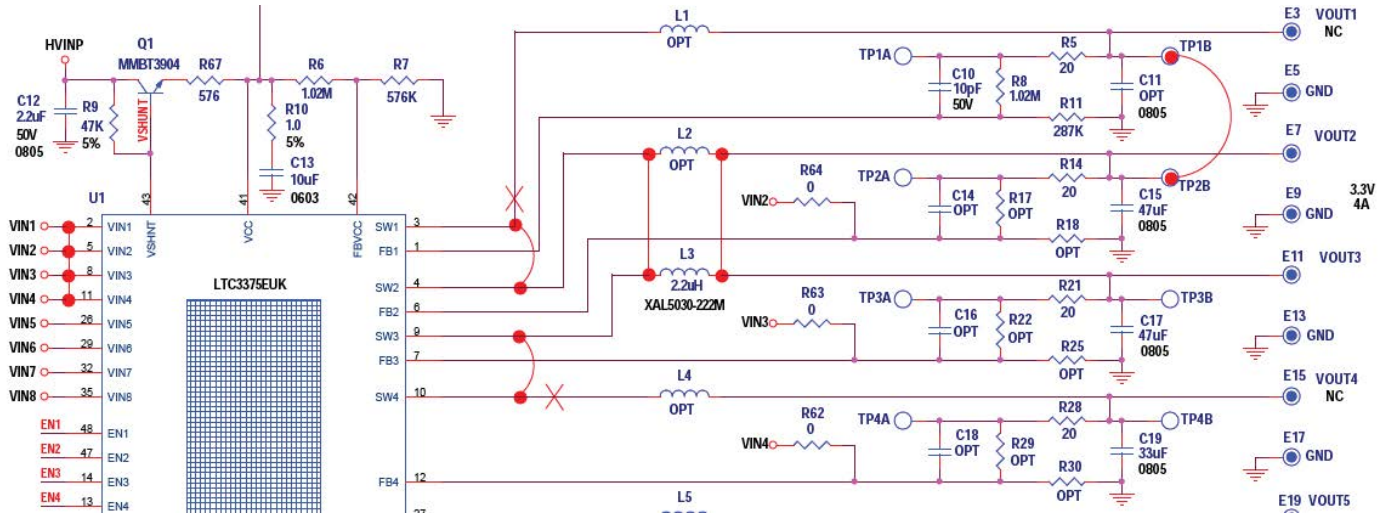

Figure 8. Combined 4A Output, Regulators 1, 2, 3 and 4

## COMBINING BUCK REGULATORS WITH A SINGLE OUTPUT FILTER

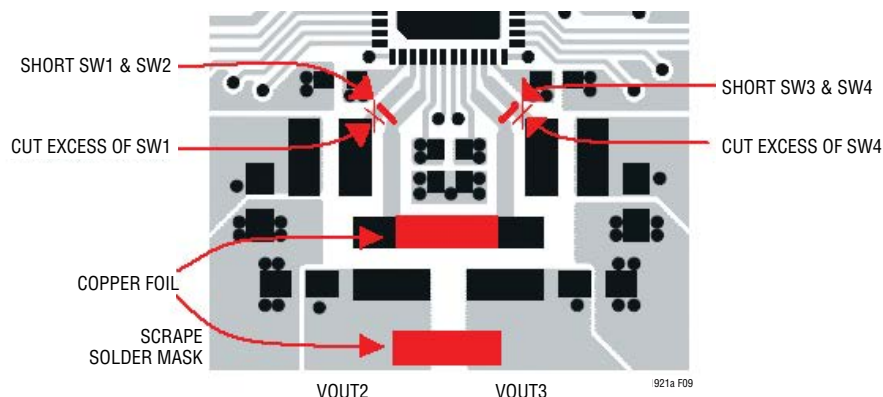

Figure 9. Copper Foil Between L2 and L3; Modified SW1 and SW4 Traces

### PARTS LIST

ITEM	QTY	REFERENCE	PART DESCRIPTION	MANUFACTURER/PART NUMBER
<b>Required Circuit Components</b>				
1	9	C1, C2, C3, C4, C5, C6, C7, C8, C13	CAP, CHIP, X5R, 10µF, ±20%, 6.3V, 0603	TDK, C1608X5R0J106M
2	8	C11, C15, C17, C19, C21, C23, C25, C27	CAP, CHIP, X5R, 33µF, ±20%, 6.3V, 0805	TDK, C2012X5R0J336M
3	1	C12	CAP, CHIP, X7R, 2.2µF, ±10%, 50V, 0805	TDK, C2012X5R1H225M
4	1	C28	CAP, CHIP, X7R, 0.01µF, ±10%, 25V, 0402	MURATA, GRM155R71E103KA01D
5	8	L1-L8	IND, SMT, 2.2µH, 21mΩ, ±20%, 3.7A, 4mm × 4mm	COILCRAFT, XFL4020-222MEB
6	1	Q1	TRANSISTOR, GP, SS, NPN, 40V, SOT23	ON-SEMI, MMBT3904
7	3	R6, R8, R22	RES, CHIP, 1.02MΩ, ±1%, 1/16W, 0402	VISHAY, CRCW04021M02FKED
8	1	R7	RES, CHIP, 576kΩ, ±1%, 1/16W, 0402	VISHAY, CRCW0402576KFKED
9	1	R9	RES, CHIP, 47kΩ, ±5%, 1/16W, 0402	VISHAY, CRCW040247K0JNED
10	1	R10	RES, CHIP, 1Ω, ±5%, 1/16W, 0402	VISHAY, CRCW04021R00JNED
11	1	R11	RES, CHIP, 287kΩ, ±1%, 1/16W, 0402	VISHAY, CRCW0402287KFKED
12	1	R17	RES, CHIP, 1.07MΩ, ±1%, 1/16W, 0402	VISHAY, CRCW04021M07FKED
13	1	R18	RES, CHIP, 340kΩ, ±1%, 1/10W, 0402	VISHAY, CRCW0402340KFKED
14	2	R25, R30	RES, CHIP, 412kΩ, ±1%, 1/10W, 0402	VISHAY, CRCW0402412KFKED
15	2	R29, R49	RES, CHIP, 732kΩ, ±1%, 1/10W, 0402	VISHAY, CRCW0402732KFKED
16	2	R34, R45	RES, CHIP, 649kΩ, ±1%, 1/16W, 0402	VISHAY, CRCW0402649KFKED
17	2	R35, R41	RES, CHIP, 432kΩ, ±1%, 1/16W, 0402	VISHAY, CRCW0402432KFKED
18	1	R40	RES, CHIP, 464kΩ, ±1%, 1/16W, 0402	VISHAY, CRCW0402464KFKED
19	1	R43	RES, CHIP, 422kΩ, ±1%, 1/16W, 0402	VISHAY, CRCW0402422KFKED
20	1	R48	RES, CHIP, 280kΩ, ±1%, 1/16W, 0402	VISHAY, CRCW0402280KFKED
21	1	U1	8-CHANNEL PROGRAMMABLE 1A BUCK DC/DCs	LINEAR TECHNOLOGY, LTC3375EUK

# DEMO MANUAL DC1921A

## PARTS LIST

ITEM	QTY	REFERENCE	PART DESCRIPTION	MANUFACTURER/PART NUMBER
<b>Additional Demo Board Circuit Components</b>				
1	8	C9, C30-C36	CAP, CHIP, X5R, 22 $\mu$ F, $\pm$ 20%, 6.3V, 0805	TAIYO YUDEN, JMK212ABJ226MG
2	8	C10, C14, C16, C18, C20, C22, C24, C26	CAP, CER, 10pF, 50V, 5%, NP0, 0402	MURATA, GRM1555C1H100JA01D
3	1	C29	CAP, CHIP, X5R, 0.1 $\mu$ F, $\pm$ 10%, 16V, 0402	MURATA, GRM155R71C104KA88
4	1	C37 (OPT)	CAP, CHIP, 0402	
5	2	D1, D2	LED, 660NM, SUPER RED DIFF, 0603, SMD	LUMEX, SML-LX0603SRW-TR
6	12	R1, R3, R12, R15, R19, R23, R26, R31, R36, R44, R51, R55	RES, CHIP, 1k $\Omega$ , $\pm$ 5%, 1/16W, 0402	VISHAY, CRCW04021K00JNED
7	10	R2, R4, R13, R16, R20, R24, R27, R32, R37, R46	RES, CHIP, 2.40M $\Omega$ , $\pm$ 5%, 1/16W, 0402	VISHAY, CRCW04022M40JNED
8	8	R5, R14, R21, R28, R33, R38, R42, R47	RES, CHIP, 20 $\Omega$ , $\pm$ 1%, 1/16W, 0402	VISHAY, CRCW040220R0FKED
9	3	R39, R52, R53	RES, CHIP, 1.00M $\Omega$ , $\pm$ 5%, 1/16W, 0402	VISHAY, CRCW04021M00JNED
10	0	R50 (OPT)	RES, CHIP, 0402	
11	3	R54, R56, R57	RES, CHIP, 5.1k $\Omega$ , $\pm$ 5%, 1/16W, 0402	VISHAY, CRCW04025K10JNED
12	0	R58-R64 (OPT)	RES, CHIP, 0 $\Omega$ JUMPER, 1/16W, 0402	VISHAY, CRCW04020000Z0ED
13	0	R65	RES, CHIP, 0 $\Omega$ JUMPER, 1/16W, 0402	VISHAY, CRCW04020000Z0ED
14	0	R66 (OPT)	RES, CHIP, 1206	
15	1	R67	RES, CHIP, 576 $\Omega$ , $\pm$ 1%, 1/10W, 0402	PANASONIC, ERJ-2RKF5760X
16	0	Q2 (OPT)	SOT223	VISHAY, CRCW040201R0FKED
17	1	U2	IC, EEPROM 2kb, 400kHz, 8TSSOP	MICROCHIP, 24LC025-I/ST
<b>Hardware: For Demo Board Only</b>				
1	28	E1-E19, E21, E23, E25, E26, E28, E30, E31, E33, E36	TURRET, 0.09" DIA	MILL-MAX, 2501-2-00-80-00-00-07-0
2	18	E20, E22, E24, E27, E29, E32, E34, E35, E37, E38-E46	TURRET, 0.061" DIA	MILL-MAX, 2308-2-00-80-00-00-07-0
3	1	J1	CONN HEADER, 14POS, 2mm VERT GOLD	MOLEX, 87831-1420
4	12	JP1-JP12	HEADER, 3-PIN, 0.079", SINGLE ROW	SULLINS, NRPN031PAEN-RC
5	12	JP1-JP12	SHUNT, 2mm	SAMTEC, 2SN-BK-G
6	1	PB1	SWITCH, PUSHBUTTON, SMT	C & K, PTS635SL25SMTRLFS
7	4		STAND-OFF NYLON, 0.375" TALL (SNAP-ON)	KEYSTONE, 8832 (SNAP-ON)
8	1		FAB, PRINTED CIRCUIT BOARD	DEMO CIRCUIT 1921A-3

**SCHEMATIC DIAGRAM**

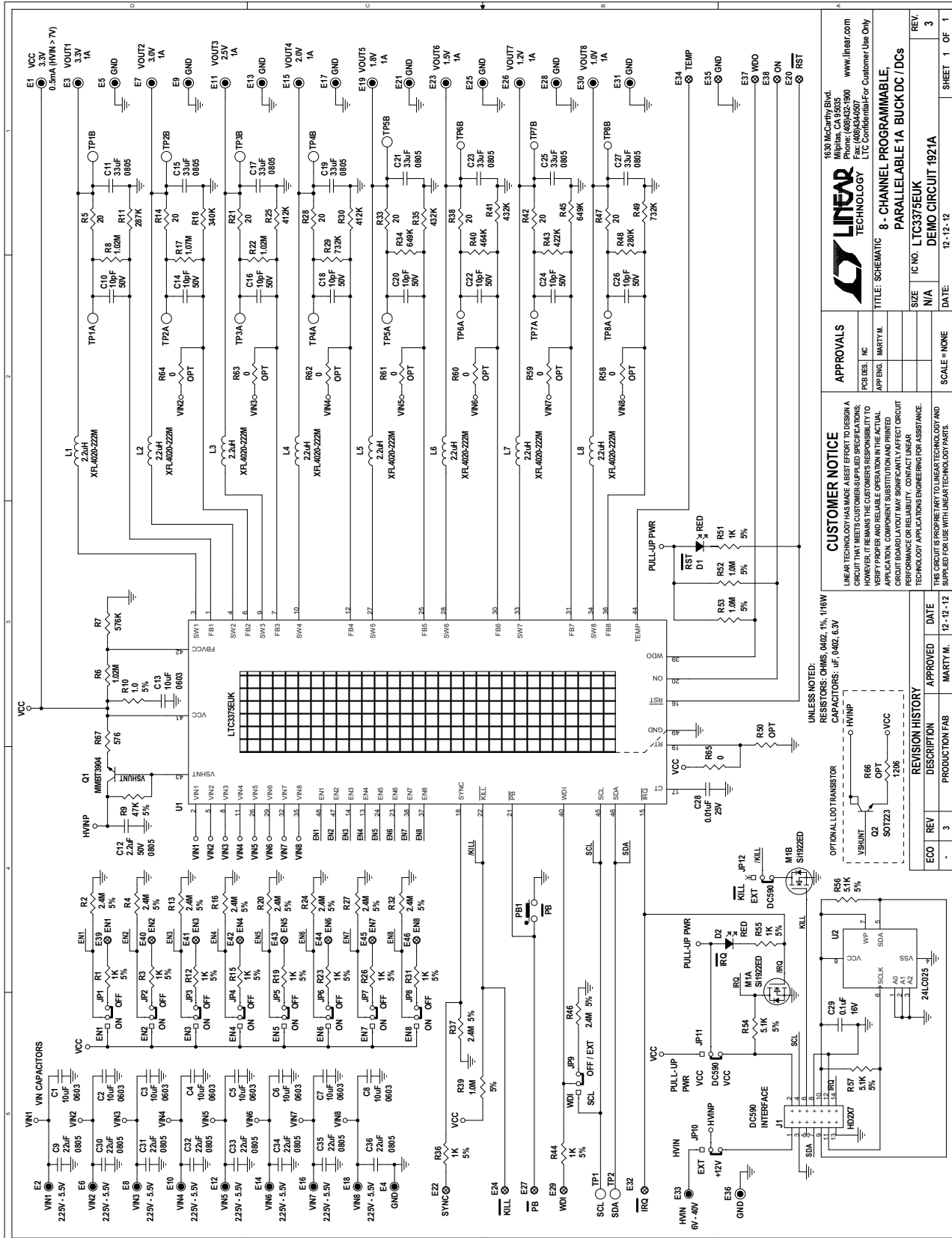



# DEMO MANUAL DC1921A

---

## DEMONSTRATION BOARD IMPORTANT NOTICE

Linear Technology Corporation (LTC) provides the enclosed product(s) under the following **AS IS** conditions:

This demonstration board (DEMO BOARD) kit being sold or provided by Linear Technology is intended for use for **ENGINEERING DEVELOPMENT OR EVALUATION PURPOSES ONLY** and is not provided by LTC for commercial use. As such, the DEMO BOARD herein may not be complete in terms of required design-, marketing-, and/or manufacturing-related protective considerations, including but not limited to product safety measures typically found in finished commercial goods. As a prototype, this product does not fall within the scope of the European Union directive on electromagnetic compatibility and therefore may or may not meet the technical requirements of the directive, or other regulations.

If this evaluation kit does not meet the specifications recited in the DEMO BOARD manual the kit may be returned within 30 days from the date of delivery for a full refund. **THE FOREGOING WARRANTY IS THE EXCLUSIVE WARRANTY MADE BY THE SELLER TO BUYER AND IS IN LIEU OF ALL OTHER WARRANTIES, EXPRESSED, IMPLIED, OR STATUTORY, INCLUDING ANY WARRANTY OF MERCHANTABILITY OR FITNESS FOR ANY PARTICULAR PURPOSE. EXCEPT TO THE EXTENT OF THIS INDEMNITY, NEITHER PARTY SHALL BE LIABLE TO THE OTHER FOR ANY INDIRECT, SPECIAL, INCIDENTAL, OR CONSEQUENTIAL DAMAGES.**

The user assumes all responsibility and liability for proper and safe handling of the goods. Further, the user releases LTC from all claims arising from the handling or use of the goods. Due to the open construction of the product, it is the user's responsibility to take any and all appropriate precautions with regard to electrostatic discharge. Also be aware that the products herein may not be regulatory compliant or agency certified (FCC, UL, CE, etc.).

No License is granted under any patent right or other intellectual property whatsoever. **LTC assumes no liability for applications assistance, customer product design, software performance, or infringement of patents or any other intellectual property rights of any kind.**

LTC currently services a variety of customers for products around the world, and therefore this transaction **is not exclusive**.

**Please read the DEMO BOARD manual prior to handling the product.** Persons handling this product must have electronics training and observe good laboratory practice standards. **Common sense is encouraged.**

This notice contains important safety information about temperatures and voltages. For further safety concerns, please contact a LTC application engineer.

Mailing Address:

Linear Technology  
1630 McCarthy Blvd.  
Milpitas, CA 95035

Copyright © 2004, Linear Technology Corporation