

FEATURES

- **Low Noise Constant Frequency Operation***
- **High Efficiency: Up to 94%**
- **Multi-Mode Operation: 1x, 1.5x or 2x Boost Modes**
- **Automatic Mode Switching**
- **High Output Current: Up to 500mA**
- Tiny Application Circuit (3mm × 3mm DFN Package, All Components <1mm High)
- Automatic Soft-Start
- Output Disconnect
- Open, Shorted LED Protection
- No Inductors
- Internal 110mΩ LED Current Sense Resistor
- 3mm × 3mm 10-Lead DFN Package

APPLICATIONS

- LED Torch/Camera Light Supply for Cell Phones, PDAs and Digital Cameras
- General Lighting and/or Flash/Strobe Applications

DESCRIPTION

The LTC[®]3214 is a low noise, high current charge pump DC/DC converter capable of driving high current LEDs at up to 500mA from a 2.9V to 4.5V input. Low external parts count (two flying capacitors, one programming resistor and two bypass capacitors at V_{IN} and CPO) make the LTC3214 ideally suited for small, battery-powered applications.

Built-in soft-start circuitry prevents excessive inrush current during start-up. High switching frequency enables the use of small external capacitors.

Output current level is programmed by an external resistor. LED current is regulated using an internal 110mΩ sense resistor. Automatic mode switching optimizes efficiency by monitoring the voltage across the charge pump and switching modes only when dropout is detected. The part is available in a low profile 3mm x 3mm 10-lead DFN package.

LT, LT, LTC and LTM are registered trademarks of Linear Technology Corporation. All other trademarks are the property of their respective owners.
*Protected by U.S. Patents including 6411531.

TYPICAL APPLICATION

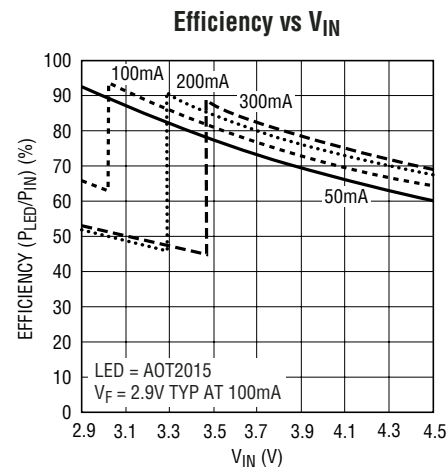
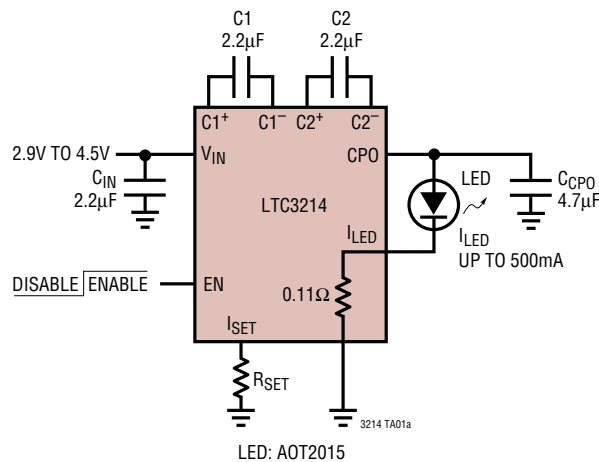

ABSOLUTE MAXIMUM RATINGS

(Note 1)

V_{IN} to GND	-0.3V to 5.5V
CPO to GND	-0.3V to 5.5V
EN	-0.3V to $V_{IN} + 0.3V$
I_{CPO} , I_{ILED} (Note 2)	600mA
CPO Short-Circuit Duration	Indefinite
Storage Temperature Range	-65°C to 125°C
Operating Temperature Range (Note 3) ..	-40°C to 85°C

PACKAGE/ORDER INFORMATION

TOP VIEW

DD PACKAGE
10-LEAD (3mm × 3mm) PLASTIC DFN
 $T_{JMAX} = 125^{\circ}C$, $\theta_{JA} = 43^{\circ}C/W$
EXPOSED PAD (PIN 11) IS GND, MUST BE SOLDERED TO PCB GND

ORDER PART NUMBER	DD PART MARKING
LTC3214EDD	LBVQ

Order Options Tape and Reel: Add #TR
Lead Free: Add #PBF Lead Free Tape and Reel: Add #TRPBF
Lead Free Part Marking: <http://www.linear.com/leadfree/>

Consult LTC Marketing for parts specified with wider operating temperature ranges.

ELECTRICAL CHARACTERISTICS

The ● denotes the specifications which apply over the full operating temperature range, otherwise specifications are at $T_A = 25^{\circ}C$. $V_{IN} = 3.6V$, $C_{IN} = C1 = C2 = 2.2\mu F$, $C_{CPO} = 4.7\mu F$.

PARAMETER	CONDITIONS	MIN	TYP	MAX	UNITS
Input Power Supply					
V_{IN} Operating Voltage		●	2.9	4.5	V
I_{VIN} Operating Current	$I_{CPO} = 0mA$, 1x Mode $I_{CPO} = 0mA$, 1.5x $I_{CPO} = 0mA$, 2x Mode		980 4.8 6.7		μA mA mA
I_{VIN} Shutdown Current	EN = LOW		2.5	7.5	μA
LED Current					
LED Current Ratio (I_{LED}/I_{SET})	$I_{LED} = 150mA$ to $500mA$		2715	2950	3190
I_{LED} Dropout Voltage (V_{ILED})	Mode Switch Threshold, $I_{LED} = 200mA$			40	mV
Mode Switching Delay (LED Warmup Time)				2.5	ms
LED Current On Time	EN \uparrow to LED Current On			100	μs
Charge Pump (CPO)					
Charge Pump Output Clamp Voltage				5	V
1x Mode Output Impedance				0.70	Ω
1.5x Mode Output Impedance				3.2	Ω
2x Mode Output Impedance				3.5	Ω
CLK Frequency	$V_{IN} = 3V$	●	0.6	0.9	1.2
EN					
High Level Input Voltage (V_{IH})		●	1.4		V
Low Level Input Voltage (V_{IL})		●		0.4	V
Input Current (I_{IH})	$V_{EN} = 3.6V$	●		14.4	20
Input Current (I_{IL})		●	-1	1	μA

ELECTRICAL CHARACTERISTICS The ● denotes the specifications which apply over the full operating temperature range, otherwise specifications are at $T_A = 25^\circ\text{C}$. $V_{IN} = 3.6\text{V}$, $C_{IN} = C_1 = C_2 = 2.2\mu\text{F}$, $C_{CPO} = 4.7\mu\text{F}$.

PARAMETER	CONDITIONS	MIN	TYP	MAX	UNITS
I_{SET}					
V _{ISET}	I _{SET} = 50μA	● 1.18	1.21	1.24	V
I _{ISET}		●		184	μA

Note 1: Stresses beyond those listed under Absolute Maximum Ratings may cause permanent damage to the device. Exposure to any Absolute Maximum Rating condition for extended periods may affect device reliability and lifetime.

Note 2: Based on long-term current density limitations. Assumes an operating duty cycle of ≤ 10% under absolute maximum conditions for

durations less than 10 seconds. Max current for continuous operation is 300mA.

Note 3: The LTC3214E is guaranteed to meet performance specifications from 0°C to 70°C. Specifications over the -40°C to 85°C ambient operating temperature range are assured by design, characterization and correlation with statistical process controls.

TYPICAL PERFORMANCE CHARACTERISTICS ($T_A = 25^\circ\text{C}$ unless otherwise specified)

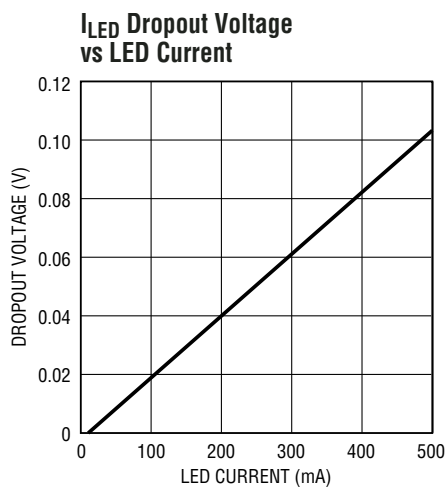

3216 G01

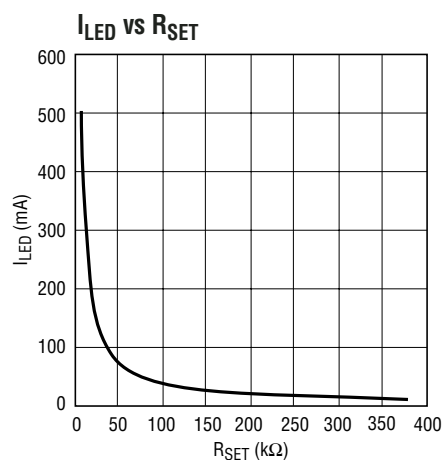

1573 G02

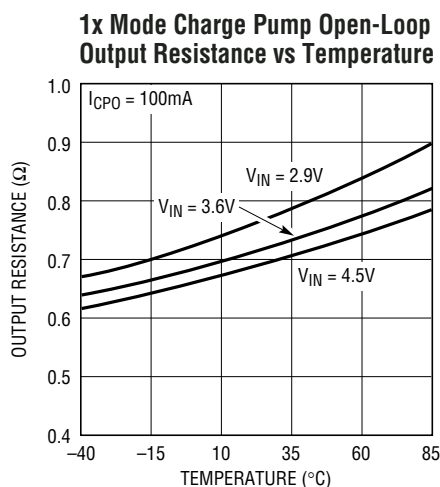

3216 G03

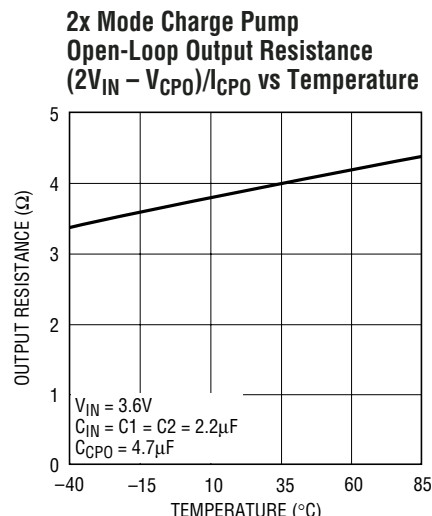

3216 G05

TYPICAL PERFORMANCE CHARACTERISTICS ($T_A = 25^\circ\text{C}$ unless otherwise specified)

Input Shutdown Current vs Input Voltage

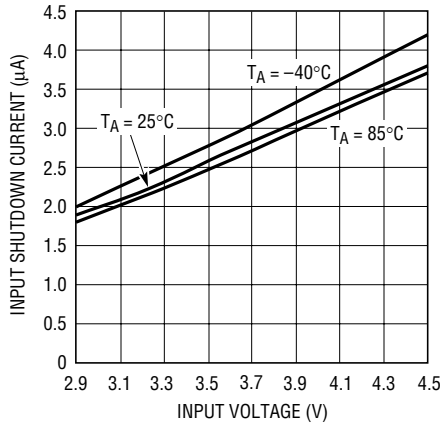

Oscillator Frequency vs Supply Voltage

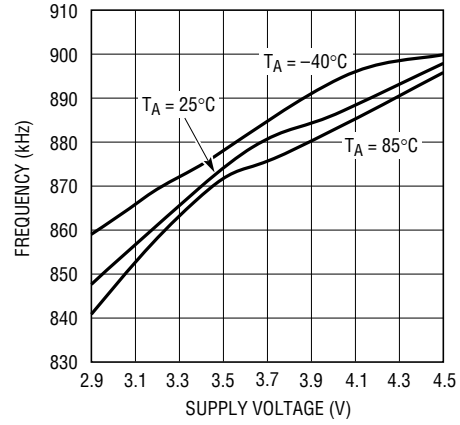

Efficiency vs V_{IN}

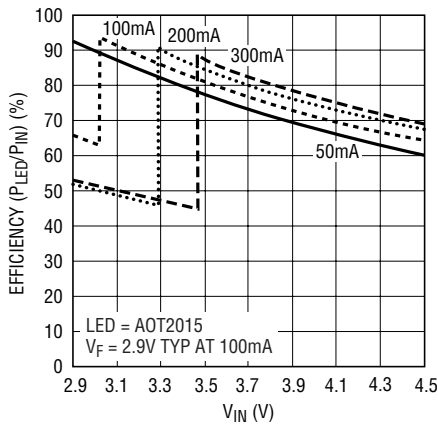

I_{SET}/I_{LED} Current Ratio vs I_{LED} Current

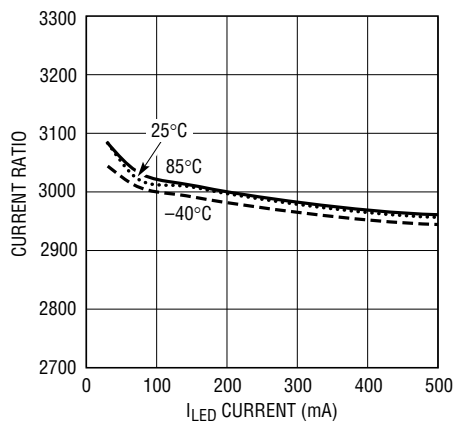

I_{LED} Current vs Input Voltage

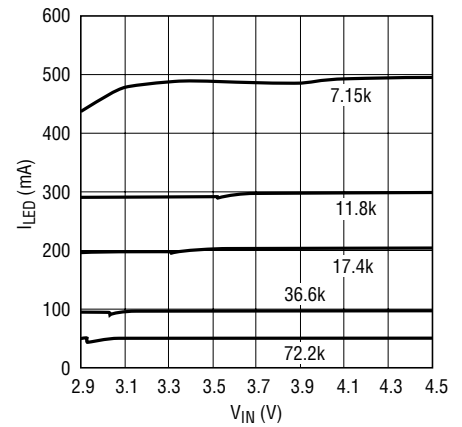

1.5x Mode CPO Output Ripple

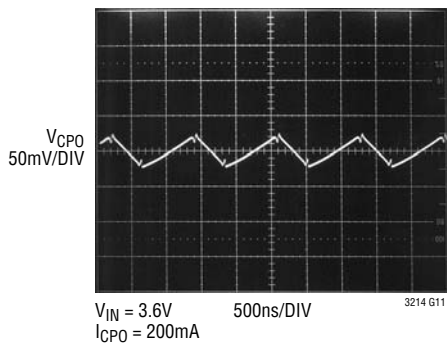

2x Mode CPO Output Ripple

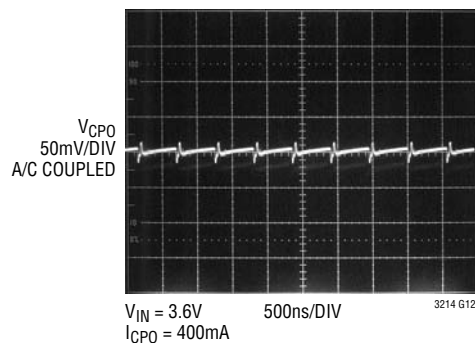

PIN FUNCTIONS

C2⁺, C1⁺, C2⁻, C1⁻ (Pins 1, 2, 8, 10): Charge Pump Flying Capacitor Pins. A 2.2 μ F X5R or X7R ceramic capacitor should be connected from C1⁺ to C1⁻ and from C2⁺ to C2⁻.

CPO (Pin 3): Output. CPO is the output of the charge pump. This pin may be enabled or disabled using the EN input. A 4.7 μ F X5R or X7R ceramic capacitor is required from CPO to GND.

I_{LED} (Pin 4): Input. I_{LED} is the LED current sense pin. The LED is connected between CPO (anode) and I_{LED} (cathode). The current into the I_{LED} pin is set by a resistor connected to the I_{SET} pin and regulated internally.

I_{SET} (Pin 5): LED Current Programming Resistor Pin. A resistor connected between this pin and GND is used to set the LED current level.

EN (Pin 6): Input. The EN pin is used to enable the part and bring it into shutdown mode. An internal 250k Ω resistor pulls this pin to GND when left floating.

V_{IN} (Pin 7): Power. Supply voltage for the LTC3214. V_{IN} should be bypassed with a 2.2 μ F to 4.7 μ F low impedance ceramic capacitor to GND.

GND (Pin 9): Charge Pump Ground. This pin should be connected directly to a low impedance ground plane.

Exposed Pad (Pin 11): Control Signal Ground. This pad must be soldered to a low impedance ground plane for optimum thermal and electrical performance.

BLOCK DIAGRAM

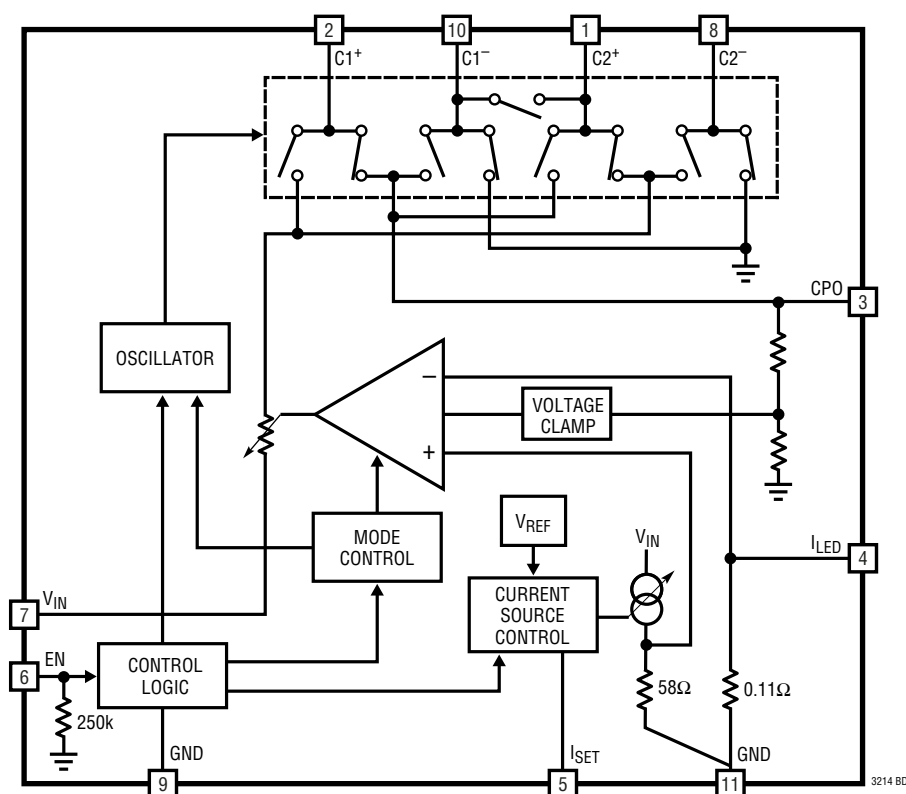

OPERATION

The LTC3214 uses a fractional switched capacitor charge pump to power a high current LED with a programmed regulated current. The part starts up into the 1x mode. In this mode, V_{IN} is directly connected to CPO. This mode provides maximum efficiency and minimum noise. The LTC3214 will remain in this mode until the forward voltage (V_F) approaches the maximum CPO voltage possible in this mode. When this dropout condition occurs, the LTC3214 will switch to 1.5x mode after a soft-start period. Any subsequent dropout detected will cause the part to enter 2x mode.

A two phase nonoverlapping clock activates the charge pump switches. In the 2x mode, the flying capacitors are charged on alternate clock phases from V_{IN} . While one capacitor is being charged from V_{IN} , the other is stacked on top of V_{IN} and connected to the output. Alternatively, in the 1.5x mode the flying capacitors are charged in series during the first clock phase, and stacked in parallel on top of V_{IN} on the second clock phase. This sequence of charging and discharging the flying capacitors continues at a free running frequency of 900kHz (typ).

The current delivered to the LED load is controlled by the internal programmable current source. The current is programmed by a resistor connected between the I_{SET} pin and GND. The resistor value needed to attain the desired current level can be determined by Equation 1.

$$R_{SET} = 3570/I_{LED} \quad (1)$$

Overcurrent shutdown mode will prevent damage to the part by shutting down the high power sections of the chip. Choosing an R_{SET} value of 5k or greater will ensure that the part stays out of this mode.

Regulation is achieved by sensing the voltage at the I_{LED} pin and modulating the charge pump strength based on the error signal.

In shutdown mode all circuitry is turned off and the LTC3214 draws a very low current from the V_{IN} supply. The output is disconnected from V_{IN} and is pulled down by a resistance of approximately 43k Ω . The LTC3214 enters shutdown mode when the EN pin is brought low.

Thermal Protection

The LTC3214 has built-in overtemperature protection. Thermal shutdown circuitry will shut down the part when the junction temperature exceeds approximately 165°C. It will re-enable the part once the junction temperature drops back to approximately 150°C. The LTC3214 will cycle in and out of thermal shutdown indefinitely without latch up or damage until the heat source is removed.

Short-Circuit Protection

When EN is brought high, the part will connect V_{IN} and CPO through a weak pull-up. If the CPO capacitor fails to charge up to over 1V (i.e. CPO is shorted), the chip will not be enabled. Similarly, during operation if CPO is pulled down below 1V, the part will be disabled.

Soft-Start

To prevent excessive inrush current during start-up and mode switching, the LTC3214 employs built-in soft-start circuitry. Soft-start is achieved by increasing the amount of current available to the output charge storage capacitor linearly over a period of approximately 150 μ s.

Charge Pump Strength

When the LTC3214 operates in either the 1.5x mode or 2x mode, the charge pump can be modeled as a Thevenin equivalent circuit to determine the amount of current available from the effective input voltage and effective open-loop output resistance, R_{OL} (Figure 1).

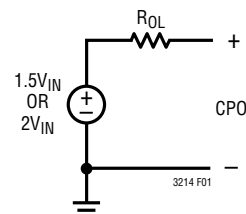

Figure 1. Charge Pump Open-Loop Thevenin-Equivalent Circuit

OPERATION

R_{OL} is dependent on a number of factors including the oscillator frequency, flying capacitor values and switch resistances. From Figure 1, we can see that the output current is proportional to:

$$\frac{1.5V_{IN} - CPO}{R_{OL}} \text{ OR } \frac{2V_{IN} - CPO}{R_{OL}}$$

in the 1.5x mode or 2x mode respectively.

LED Current Programming

The LTC3214 includes an accurate, programmable current source that is capable of driving LED currents up to 300mA continuously and up to 500mA for pulsed operation. Pulsed operation may be achieved by toggling the EN pin. In either continuous or pulsed operation, proper board layout is required for effective heat sinking.

The current may be programmed using a single external resistor. Equation 1, used to calculate the resistor value from the desired current level is repeated below:

$$R_{SET} = 3570/I_{LED}$$

For applications requiring multiple current levels, several schemes may be used to change the resistance for the R_{SET} resistor. Figure 2 shows one such scheme. The circuit in Figure 2 uses the I/O output of a microcontroller to switch a second resistor (R_2) in parallel or series with R_1 , changing the effective I_{SET} current.

Mode Switching

The LTC3214 will automatically switch from 1x mode to 1.5x mode, and subsequently from 1.5x mode to 2x mode whenever the LED forward voltage approaches the maximum CPO voltage for that mode. The part will wait approximately 2.5ms before switching to the next mode. This delay allows the LED to warm up and reduce its forward voltage which may remove the dropout condition. The part may be reset to 1X mode by bringing the part into shutdown by setting the EN pin low. Once the EN pin is low, it may be immediately brought high to re-enable the part.

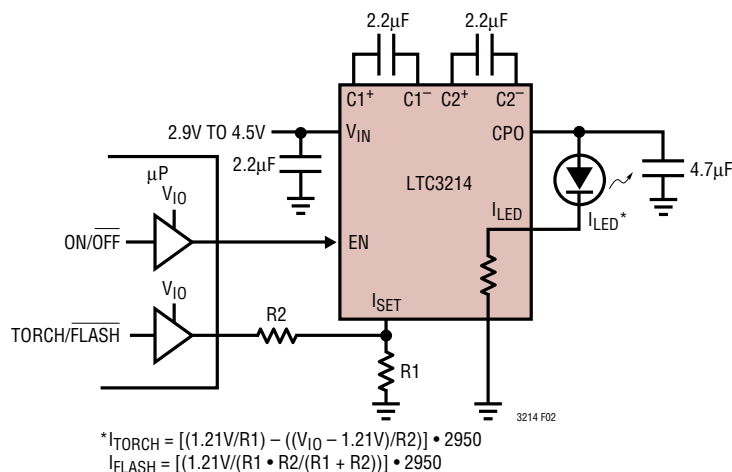

Figure 2. Recommended Circuit for Attaining Two Current Levels (Torch and Flash Modes)

APPLICATIONS INFORMATION

V_{IN} , CPO Capacitor Selection

The value and type of capacitors used with the LTC3214 determine several important parameters such as regulator control loop stability, output ripple, charge pump strength and minimum start-up time.

To reduce noise and ripple, it is recommended that low equivalent series resistance (ESR) ceramic capacitors be used for both C_{VIN} and C_{CPO} . Tantalum and aluminum capacitors are not recommended because of their high ESR.

The value of C_{CPO} directly controls the amount of output ripple for a given load current. Increasing the size of C_{CPO} will reduce the output ripple at the expense of higher start-up current. The peak-to-peak output ripple for 1.5x mode is approximately given by the expression:

$$V_{RIPPLE(P-P)} = I_{OUT} / (3f_{OSC} \cdot C_{CPO})$$

Where f_{OSC} is the LTC3214's oscillator frequency (typically 900kHz) and C_{CPO} is the output storage capacitor.

Both the style and value of the output capacitor can significantly affect the stability of the LTC3214. As shown in the Block Diagram, the LTC3214 uses a control loop to adjust the strength of the charge pump to match the current required at the output. The error signal of this loop is stored directly on the output charge storage capacitor. The charge storage capacitor also serves as the dominant pole for the control loop. To prevent ringing or instability, it is important for the output capacitor to maintain at least 3 μ F of actual capacitance over all conditions.

Likewise, excessive ESR on the output capacitor will tend to degrade the loop stability of the LTC3214. To prevent poor load transient response and instability, the ESR of the output capacitor should be kept below 50m Ω . Multilayer ceramic chip capacitors typically have exceptional ESR performance. MLCCs combined with a tight board layout will yield very good stability. As the value of C_{CPO} controls the amount of output ripple, the value of C_{VIN} controls the amount of ripple present at the input pin (V_{IN}). The input current to the LTC3214 will be relatively constant while the charge pump is on either the input charging phase or the output charging phase but will drop to zero during the clock nonoverlap times. Since the nonoverlap time is

small (~15ns), these missing “notches” will result in only a small perturbation on the input power supply line. Note that a higher ESR capacitor such as tantalum will have higher input noise due to the input current change times the ESR. Therefore, ceramic capacitors are again recommended for their exceptional ESR performance. Input noise can be further reduced by powering the LTC3214 through a very small series inductor as shown in Figure 3. A 10nH inductor will reject the fast current notches, thereby presenting a nearly constant current load to the input power supply. For economy, the 10nH inductor can be fabricated on the PC board with about 1cm (0.4") of PC board trace.

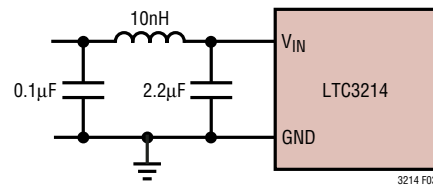

Figure 3. 10nH Inductor Used for Input Noise Reduction (Approximately 1cm of Wire)

Flying Capacitor Selection

Warning: Polarized capacitors such as tantalum or aluminum should never be used for the flying capacitors since their voltage can reverse upon start-up of the LTC3214. Ceramic capacitors should always be used for the flying capacitors.

The flying capacitors control the strength of the charge pump. In order to achieve the rated output current it is necessary to have at least 1.6 μ F of actual capacitance for each of the flying capacitors. Capacitors of different materials lose their capacitance with higher temperature and voltage at different rates. For example, a ceramic capacitor made of X7R material will retain most of its capacitance from -40°C to 85°C whereas a Z5U or Y5V style capacitor will lose considerable capacitance over that range. Z5U and Y5V capacitors may also have a very poor voltage coefficient causing them to lose 60% or more of their capacitance when the rated voltage is applied. Therefore, when comparing different capacitors, it is often more appropriate to

APPLICATIONS INFORMATION

compare the amount of achievable capacitance for a given case size rather than comparing the specified capacitance value. For example, over rated voltage and temperature conditions, a 1 μ F, 10V, Y5V ceramic capacitor in a 0603 case may not provide any more capacitance than a 0.22 μ F, 10V, X7R available in the same case. The capacitor manufacturer's data sheet should be consulted to determine what value of capacitor is needed to ensure minimum capacitances at all temperatures and voltages.

Table 1 shows a list of ceramic capacitor manufacturers and how to contact them.

Table 1. Recommended Capacitor Vendors

AVX	www.avxcorp.com
Kemet	www.kemet.com
Murata	www.murata.com
Taiyo Yuden	www.t-yuden.com
Vishay	www.vishay.com
TDK	www.tdk.com

Layout Considerations and Noise

Due to the high switching frequency and the transient currents produced by the LTC3214, careful board layout is necessary. A true ground plane and short connections to all capacitors will improve performance and ensure proper regulation under all conditions. An example of such a layout is shown in Figure 4.

The flying capacitor pins C1⁺, C2⁺, C1⁻ and C2⁻ will have very high edge rate waveforms. The large dv/dt on these

pins can couple energy capacitively to adjacent PCB runs. Magnetic fields can also be generated if the flying capacitors are not close to the LTC3214 (i.e., the loop area is large). To decouple capacitive energy transfer, a Faraday shield may be used. This is a grounded PCB trace between the sensitive node and the LTC3214 pins. For a high quality AC ground, it should be returned to a solid ground plane that extends all the way to the LTC3214.

The following guidelines should be followed when designing a PCB layout for the LTC3214.

- The Exposed Pad should be soldered to a large copper plane that is connected to a solid, low impedance ground plane using plated, through-hole vias for proper heat sinking and noise protection.
- Input and output capacitors (C_{IN} and C_{CPO}) must also be placed as close to the part as possible.
- The flying capacitors must also be placed as close to the part as possible. The traces running from the pins to the capacitor pads should be as wide as possible.
- V_{IN}, CPO and I_{LED} traces must be made as wide as possible. This is necessary to minimize inductance, as well as provide sufficient area for high current applications.
- LED pads must be large and should be connected to as much solid metal as possible to ensure proper heat sinking.

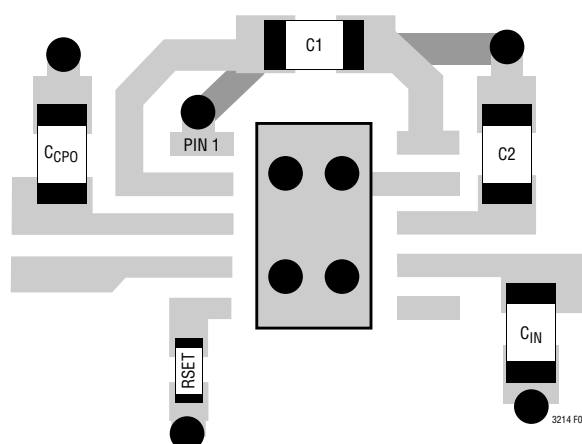

Figure 4. Example Board Layout

APPLICATIONS INFORMATION

Power Efficiency

To calculate the power efficiency (η) of a white LED driver chip, the LED power should be compared to the input power. The difference between these two numbers represents lost power whether it is in the charge pump or the current sources. Stated mathematically, the power efficiency is given by:

$$\eta \equiv \frac{P_{LED}}{P_{IN}}$$

The efficiency of the LTC3214 depends upon the mode in which it is operating. Recall that the LTC3214 operates as a pass switch, connecting V_{IN} to CPO, until dropout is detected at the I_{LED} pin. This feature provides the optimum efficiency available for a given input voltage and LED forward voltage. When it is operating as a switch, the efficiency is approximated by:

$$\eta \equiv \frac{P_{LED}}{P_{IN}} = \frac{V_{LED} \cdot I_{LED}}{V_{IN} \cdot I_{IN}} \approx \frac{V_{LED}}{V_{IN}}$$

since the input current will be very close to the LED current.

At moderate to high output power, the quiescent current of the LTC3214 is negligible and the expression above is valid.

Once dropout is detected at the I_{LED} pin, the LTC3214 enables the charge pump in 1.5x mode.

In 1.5x boost mode, the efficiency is similar to that of a linear regulator with an effective input voltage of 1.5 times the actual input voltage. This is because the input current for a 1.5x charge pump is approximately 1.5 times the load current. In an ideal 1.5x charge pump, the power efficiency would be given by:

$$\eta_{IDEAL} \equiv \frac{P_{LED}}{P_{IN}} = \frac{V_{LED} \cdot I_{LED}}{V_{IN} \cdot 1.5I_{LED}} \approx \frac{V_{LED}}{1.5V_{IN}}$$

Similarly, in 2x boost mode, the efficiency is similar to that of a linear regulator with an effective input voltage of 2 times the actual input voltage. In an ideal 2x charge pump, the power efficiency would be given by:

$$\eta_{IDEAL} \equiv \frac{P_{LED}}{P_{IN}} = \frac{V_{LED} \cdot I_{LED}}{V_{IN} \cdot 2 \cdot I_{LED}} \approx \frac{V_{LED}}{2V_{IN}}$$

Thermal Management

For higher input voltages and maximum output current, there can be substantial power dissipation in the LTC3214. If the junction temperature increases above approximately 165°C, the thermal shutdown circuitry will automatically deactivate the output. To reduce maximum junction temperature, a good thermal connection to the PC board is recommended. Connecting the Exposed Pad to a ground plane and maintaining a solid ground plane under the device can reduce the thermal resistance of the package and PC board considerably.

TYPICAL APPLICATION

High Power Camera Light and Flash

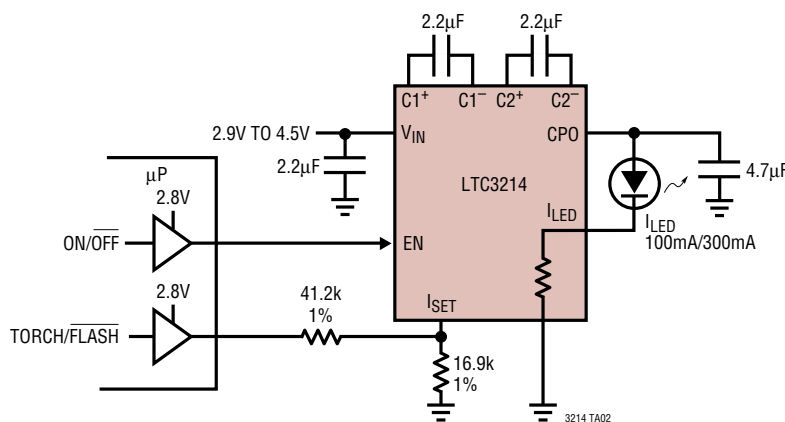

RELATED PARTS

PART NUMBER	DESCRIPTION	COMMENTS
LT1618	Constant Current, 1.4MHz, 1.5A Boost Converter	V_{IN} : 1.6V to 18V, $V_{OUT(MAX)}$ = 36V, I_Q = 1.8mA, I_{SD} < 1µA MS Package
LT1961	1.5A (I_{SW}), 1.25MHz, High Efficiency Step-Up DC/DC Converter	V_{IN} : 3V to 25V, $V_{OUT(MAX)}$ = 35V, I_Q = 0.9mA, I_{SD} < 6µA MS8E Package
LTC3205	250mA, 1MHz, Multi-Display LED Controller	V_{IN} : 2.8V to 4.5V, $V_{OUT(MAX)}$ = 5.5V, I_Q = 50µA, I_{SD} < 1µA DFN Package
LTC3206	400mA, 800kHz, Multi-Display LED Controller	V_{IN} : 2.8V to 4.5V, $V_{OUT(MAX)}$ = 5.5V, I_Q = 50µA, I_{SD} < 1µA DFN Package
LTC3208	High Current Software Configurable Multidisplay LED Controller	95% Efficiency, V_{IN} : 2.9V to 4.5V, $V_{OUT(MAX)}$: 5.5V, I_Q = 280µA, I_{SD} < 1µA, (5mm × 5mm) QFN-32 Package
LTC3215	700mA Low Noise High Current LED Charge Pump	V_{IN} : 2.9V to 4.4V, $V_{OUT(MAX)}$ = 5.5V, I_Q = 300µA, I_{SD} < 2.5µA (3mm × 3mm) DFN Package
LTC3216	1A Low Noise High Current LED Charge Pump with Independent Flash/Torch Current Control	V_{IN} : 2.9V to 4.4V, $V_{OUT(MAX)}$ = 5.5V, I_Q = 300µA, I_{SD} < 2.5µA (3mm × 4mm) DFN Package
LTC3440/LTC3441	600mA/1.2A I_{OUT} , 2MHz/1MHz, Synchronous Buck-Boost DC/DC Converter	V_{IN} : 2.4V to 5.5V, $V_{OUT(MAX)}$ = 5.25V, I_Q = 25µA/50µA, I_{SD} < 1µA MS, DFN Packages
LTC3443	600mA/1.2A I_{OUT} , 600kHz, Synchronous Buck-Boost DC/DC Converter	V_{IN} : 2.4V to 5.5V, $V_{OUT(MAX)}$ = 5.25V, I_Q = 28µA, I_{SD} < 1µA DFN Package
LTC3453	1MHz, 800mA Synchronous Buck-Boost High Power LED Driver	V_{IN} : 2.7V to 5.5V, V_{OUT} : 2.7V to 4.5V, I_Q = 2.5mA, I_{SD} < 6µA QFN Package
LT3467/LT3467A	1.1A (I_{SW}), 1.3/2.1MHz, High Efficiency Step-Up DC/DC Converters with Integrated Soft-Start	V_{IN} : 2.4V to 16V, $V_{OUT(MAX)}$ = 40V, I_Q = 1.2mA, I_{SD} < 1µA ThinSOT Package
LT3479	3A, 42V, 3.5MHz Boost Converter	V_{IN} : 2.5V to 24V, $V_{OUT(MAX)}$ = 40V, I_Q = 2µA, I_{SD} < 1µA DFN, TSSOP Packages