

LTC3115EDHD-2 40V, 2A Synchronous Buck-Boost DC/DC Converter

DESCRIPTION

Demonstration circuit 2119A features the [LTC[®]3115-2](#), a high voltage monolithic synchronous buck-boost converter optimized for applications with fast input voltage transients.

The DC2119A demo board has two user selectable operating modes: Burst Mode[®] and Forced Continuous Operation (Fixed Frequency PWM) (JP1). There is also an accurate programmable RUN pin which is used to ENABLE the converter (JP2).

The DC2119A operates with a 2.7V to 40V input voltage range. The demo board has been designed with the output voltage set to 5.0V. The LTC3115-2 incorporates a proprietary low noise switching algorithm which optimizes efficiency with input voltages above, below or equal to the output voltage and ensures seamless transitions between operating modes.

The demo board has been programmed to operate at 750kHz in PWM mode to optimize small size with high efficiency operation.

The demo board also has optional provisions to back-feed V_{CC} in order to increase efficiency in some 5V output applications. There is also a provision for an optional Schottky diode from SW2 to V_{OUT} for applications where V_{OUT} is greater than 20V and short-circuit protection is desired. Consult the data sheet for more information on these options.

Figures 1 and 2 show typical demo board efficiency. Figure 3 shows the response to an input voltage step.

The LTC3115-2 data sheet has detailed information about the operation, specifications, and applications of the part. The data sheet should be read in conjunction with this Quick Start Guide.

Design files for this circuit board are available at <http://www.linear.com/demo/DC2119A>

LT, LT, LTC, LTM, Burst Mode, Linear Technology and the Linear logo are registered trademarks of Linear Technology Corporation. All other trademarks are the property of their respective owners.

PERFORMANCE SUMMARY

Input Voltage Range	2.7V to 40V
V_{OUT}	5.0V
I_{OUT} (see Note 1)	0.8A for $V_{IN} > 3.6V$, 2A for $V_{IN} > 6V$
Efficiency	See Figures 1 & 2

NOTE 1: The demo board output current is a function of V_{IN} . Please refer to the data sheet for more information.

QUICK START PROCEDURE

Using short twisted pair leads for any power connections and with all loads and power supplies off, refer to Figure 4 for the proper measurement and equipment setup. The Battery/Power Supply (PS1) should not be connected to the circuit until told to do so in the procedure below.

When measuring the input or output voltage ripple, care must be taken to avoid a long ground lead on the oscilloscope probe. Measure the input or output voltage ripple by touching the probe tip directly across the V_{IN} or V_{OUT} and GND terminals (see Figure 5), or by using an oscilloscope probe tip jack.

1. Jumper and PS1 settings to start:

PS1 = OFF

JP1 (PWM) = FIXED FREQUENCY

JP2 (RUN) = ON

2. With power OFF connect the power supply (PS1) as shown in Figure 4. If accurate current measurements are desired (for efficiency calculation for example) then connect an ammeter in series with the supply as shown. The ammeter is not required however.

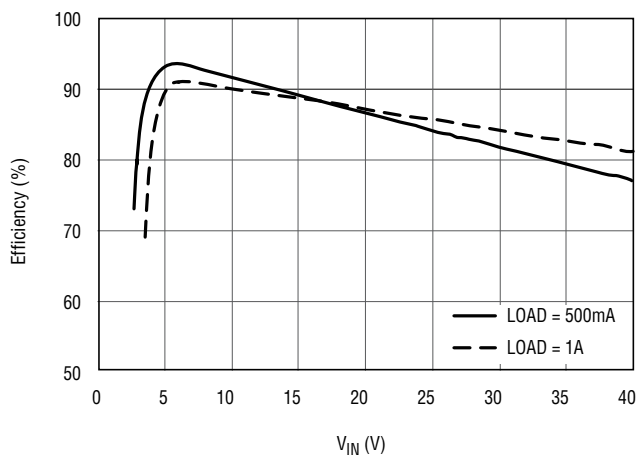

Figure 1. DC2119A Efficiency in PWM Mode

3. Connect a 500mA load to V_{OUT} as shown in Figure 2 (10Ω for $V_{OUT} = 5V$). Connect an ammeter if accurate current measurement or monitoring is desired.
4. Turn on PS1 and slowly increase voltage until the voltage at V_{IN} is 4.0V.
5. Verify V_{OUT} is $\sim 5.0V$.
6. V_{IN} can now be varied between 2.7V and 40.0V. V_{OUT} should remain in regulation.
7. Load current (I_{OUT}) can also be varied. The maximum I_{OUT} is a function of V_{IN} and the current limit. Consult the datasheet for more information on I_{OUT} vs V_{IN} . In general for $V_{IN} > 3.6V$ I_{OUT} can be increased to 0.8A. For $V_{IN} > 6V$ I_{OUT} can be increased to 2A.
8. For operation in Burst Mode move Jumper JP1 to BURST. I_{OUT} is limited in Burst Mode. See the data sheet for more information.
9. NOTE: If V_{OUT} drops out of regulation, check to be sure the maximum load has not been exceeded, or that V_{IN} is not below the minimum value for regulation (see data sheet)

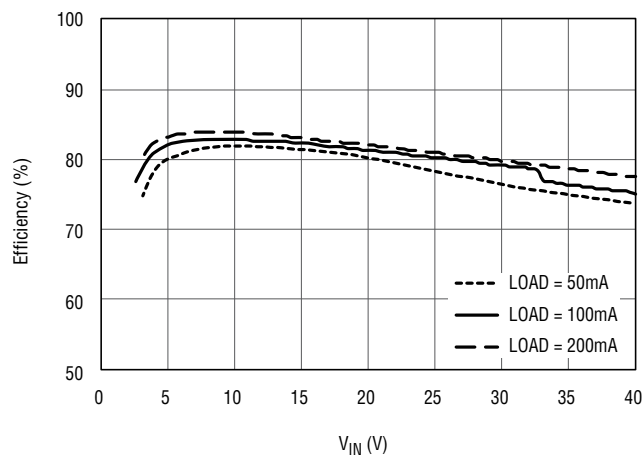

Figure 2. DC2119A Efficiency in Burst Mode

QUICK START PROCEDURE

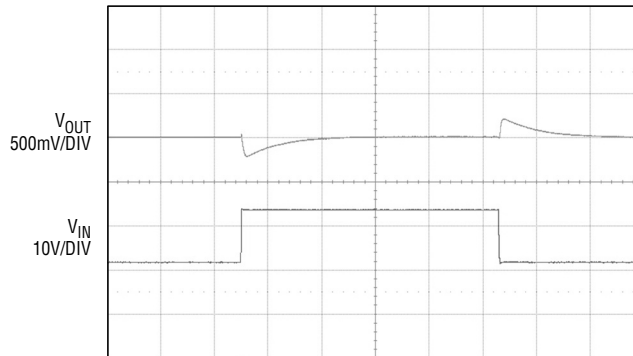

Figure 3. DC2119A Step Input Response

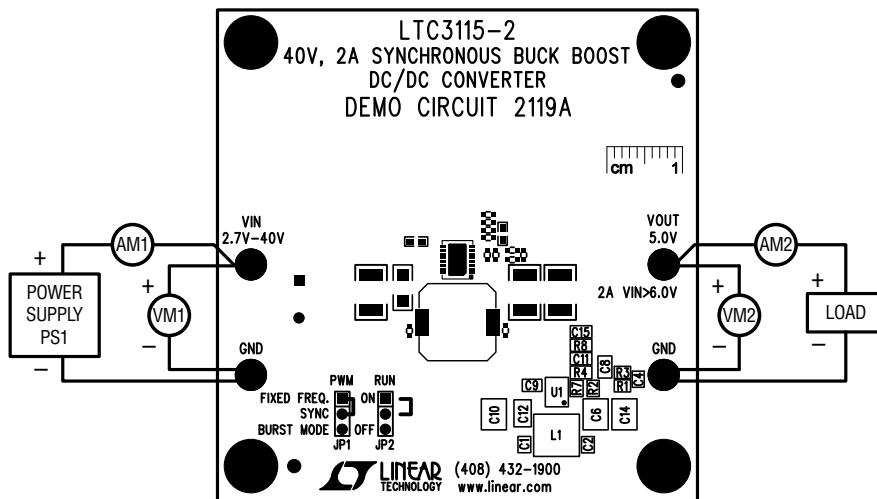

Figure 4. Proper Measurement Equipment Setup

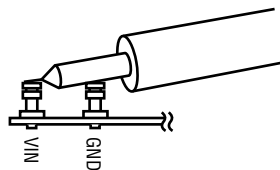

Figure 5. Measuring Input or Output Ripple

DEMO MANUAL DC2119A

PARTS LIST

ITEM	QTY	REFERENCE	PART DESCRIPTION	MANUFACTURER/PART NUMBER
Required Circuit Components				
1	2	C1, C2	CAP CER 0.10µF, 16V, X7R, ±20%, 0402	TDK, C1005X7R1C104M
2	1	C4	CAP CER, 33pF, 50V, C0G, 5%, 0402	TDK, C1005C0G1H330J
3	2	C6, C14	CAP CER, 47µF, 10V, 20%, X5R, 1812	TDK, C4532X5R1A476M
4	1	C7	CAP CER, 1.0µF, 25V, X5R, 0603	TDK, C1608X5R1E105M
5	1	C8	CAP CER, 3300pF, 50V, 5%, NP0, 0603	TDK, C1608C0G1H332J
6	1	C9	CAP CER, 4.7µF, 6.3V, X5R, 20%, 0603	TDK, C1608X5R0J475M
7	1	C10	CAP CER, 4.7µF, 50V, 20%, X7R, 1812	TDK, C4532X7R1H475M/2.00
8	1	C11	CAP CER, 10pF, 50V, C0G, 0402	TDK, C1005C0G1H100D
9	1	C12	CAP CER, 1.0µF, 50V, X7R, 20%, 1206	TDK, C3216X7R1H105M
10	1	C13	CAP CER, 0.1µF, 50V, 20%, X7R, 0805	TDK, C2012X7R1H104M/0.85
11	1	L1	INDUCTOR, 10µH, ±20%	COILCRAFT, MSS1048-103MLB
12	2	R1, R6	RES, 1.00MΩ, 1/16W, 1%, 0402, SMD	VISHAY, CRCW04021M00FKED
13	1	R2	RES, 249kΩ, 1/16W, 1%, 0402, SMD	VISHAY, CRCW0402249KFED
14	1	R3	RES, 15.0kΩ, 1/10W, 1%, 0402, SMD	PANASONIC, ERJ-2RKF1502X
15	1	R4	RES 137KΩ, 1/10W, 1%, 0402, SMD	PANASONIC, ERJ-2RKF1373X
16	1	R7	RES, 47.5kΩ, 1/16W, 1%, 0402, SMD	VISHAY, CRCW040247K5FKED
17		R8	RES 0.0Ω, 1/10W, JUMP 0402 SMD	PANASONIC, ERJ-2GE0R00X
18	1	U1	40V, 2A BUCK BOOST DC/DC CONVERTER	LINEAR TECHNOLOGY, LTC3115EDHD-2
Additional Demo Board Circuit Components				
1	0	C3, C15	0402 (OPT)	
2	0	C5	CAP ALUM 150µF, 50V, 20%, RADIAL (OPT)	PANASONIC, EEU-FM1H151
3	0	D1	DIODE SCHOTTKY, 20V, 1A, SOD323 (OPT)	NXP SEMI, PMEG2010EA
4	0	D2	DIODE SCHOTTKY 60V, 3A, SMA (OPT)	DIODES INC., B360A-13
5	0	R5	RES, 0402 (OPT)	
Hardware: For Demo Board Only				
1	4	E1-E4	TP, TURRET, 0.094", PBF	MILL-MAX, 2501-2-00-80-00-00-07-0
2	2	JP1, JP2	JMP, 3-PIN, 1 ROW .079CC	SAMTEC, TMM-103-02-L-S
3	2	XJP1, XJP2	SHUNT, .079" CENTER	SAMTEC, 2SN-BK-G
4	4		SPACER STACKING #4 SCREW NYLON .500"	KEYSTONE, 8833

SCHEMATIC DIAGRAM

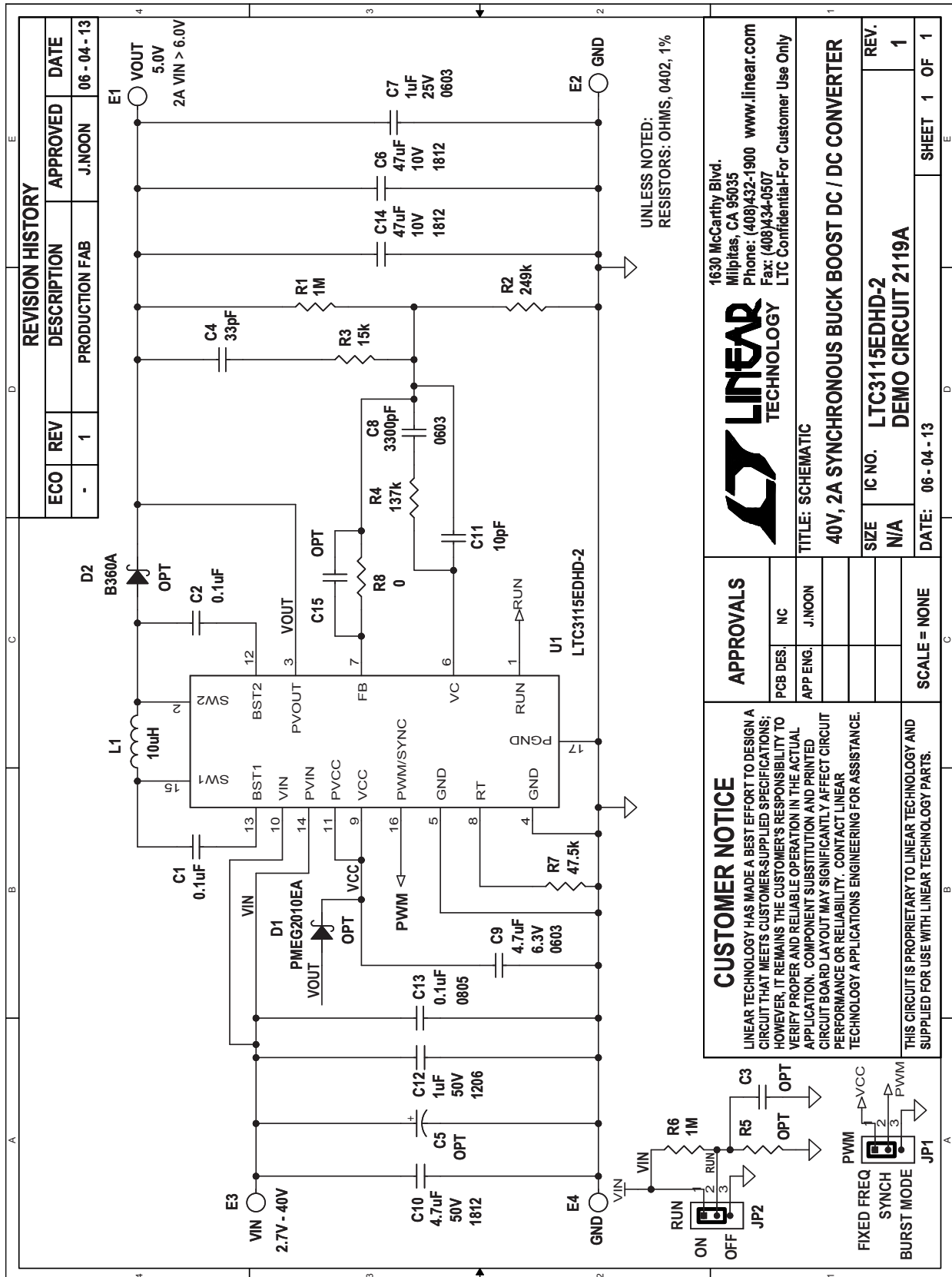

dc2119af

DEMO MANUAL DC2119A

DEMONSTRATION BOARD IMPORTANT NOTICE

Linear Technology Corporation (LTC) provides the enclosed product(s) under the following **AS IS** conditions:

This demonstration board (DEMO BOARD) kit being sold or provided by Linear Technology is intended for use for **ENGINEERING DEVELOPMENT OR EVALUATION PURPOSES ONLY** and is not provided by LTC for commercial use. As such, the DEMO BOARD herein may not be complete in terms of required design-, marketing-, and/or manufacturing-related protective considerations, including but not limited to product safety measures typically found in finished commercial goods. As a prototype, this product does not fall within the scope of the European Union directive on electromagnetic compatibility and therefore may or may not meet the technical requirements of the directive, or other regulations.

If this evaluation kit does not meet the specifications recited in the DEMO BOARD manual the kit may be returned within 30 days from the date of delivery for a full refund. **THE FOREGOING WARRANTY IS THE EXCLUSIVE WARRANTY MADE BY THE SELLER TO BUYER AND IS IN LIEU OF ALL OTHER WARRANTIES, EXPRESSED, IMPLIED, OR STATUTORY, INCLUDING ANY WARRANTY OF MERCHANTABILITY OR FITNESS FOR ANY PARTICULAR PURPOSE. EXCEPT TO THE EXTENT OF THIS INDEMNITY, NEITHER PARTY SHALL BE LIABLE TO THE OTHER FOR ANY INDIRECT, SPECIAL, INCIDENTAL, OR CONSEQUENTIAL DAMAGES.**

The user assumes all responsibility and liability for proper and safe handling of the goods. Further, the user releases LTC from all claims arising from the handling or use of the goods. Due to the open construction of the product, it is the user's responsibility to take any and all appropriate precautions with regard to electrostatic discharge. Also be aware that the products herein may not be regulatory compliant or agency certified (FCC, UL, CE, etc.).

No License is granted under any patent right or other intellectual property whatsoever. **LTC assumes no liability for applications assistance, customer product design, software performance, or infringement of patents or any other intellectual property rights of any kind.**

LTC currently services a variety of customers for products around the world, and therefore this transaction **is not exclusive**.

Please read the DEMO BOARD manual prior to handling the product. Persons handling this product must have electronics training and observe good laboratory practice standards. **Common sense is encouraged.**

This notice contains important safety information about temperatures and voltages. For further safety concerns, please contact a LTC application engineer.

Mailing Address:

Linear Technology
1630 McCarthy Blvd.
Milpitas, CA 95035

Copyright © 2004, Linear Technology Corporation