

## FEATURES

- 73.1dB SNR
- 88dB SFDR
- Low Power: 89mW
- Single 1.8V Supply
- CMOS, DDR CMOS or DDR LVDS Outputs
- Selectable Input Ranges: 1V<sub>P-P</sub> to 2V<sub>P-P</sub>
- 800MHz Full-Power Bandwidth S/H
- Optional Data Output Randomizer
- Optional Clock Duty Cycle Stabilizer
- Shutdown and Nap Modes
- Serial SPI Port for Configuration
- 40-Pin (6mm × 6mm) QFN Package

## APPLICATIONS

- Communications
- Cellular Base Stations
- Software Defined Radios
- Portable Medical Imaging
- Multi-Channel Data Acquisition
- Nondestructive Testing

## DESCRIPTION

The LTC<sup>®</sup>2259-16 is a sampling 16-bit A/D converter designed for digitizing high frequency, wide dynamic range signals. It is perfect for demanding communications applications with AC performance that includes 73.1dB SNR and 88dB spurious free dynamic range (SFDR). Ultralow jitter of 0.17ps<sub>RMS</sub> allows undersampling of IF frequencies with excellent noise performance.

DC specs include ±4LSB INL (typical) and ±0.5LSB DNL (typical).

The digital outputs can be either full-rate CMOS, double-data rate CMOS, or double-data rate LVDS. A separate output power supply allows the CMOS output swing to range from 1.2V to 1.8V.

The ENC<sup>+</sup> and ENC<sup>-</sup> inputs may be driven differentially or single ended with a sine wave, PECL, LVDS, TTL or CMOS inputs. An optional clock duty cycle stabilizer allows high performance at full speed for a wide range of clock duty cycles.

LT, LTC, LTM, Linear Technology and the Linear logo are registered trademarks of Linear Technology Corporation. All other trademarks are the property of their respective owners.

## TYPICAL APPLICATION

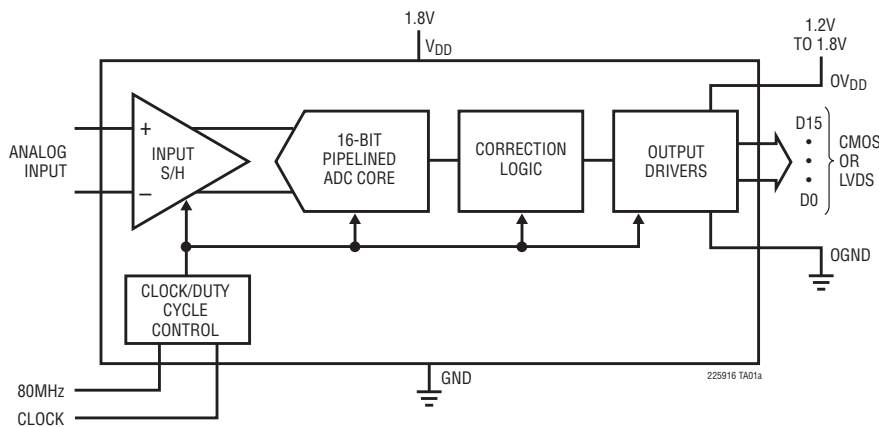

**2-Tone FFT,  $f_{IN} = 70\text{MHz}$  and  $75\text{MHz}$**

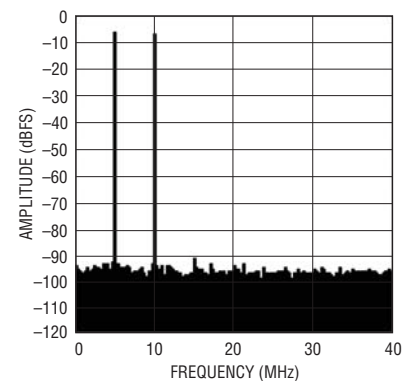

225916 TA01b

**ABSOLUTE MAXIMUM RATINGS** (Notes 1, 2)

Supply Voltages ( $V_{DD}$ , $OV_{DD}$ ).....	-0.3V to 2V	Digital Output Voltage.....	-0.3V to ( $OV_{DD} + 0.3V$ )
Analog Input Voltage ( $A_{IN}^+$ , $A_{IN}^-$ , PAR/SER, SENSE) (Note 3).....	-0.3V to ( $V_{DD} + 0.2V$ )	Operating Temperature Range:	
Digital Input Voltage ( $ENC^+$ , $ENC^-$ , CS, SDI, SCK) (Note 4).....	-0.3V to 3.9V	LTC2259C.....	0°C to 70°C
SDO (Note 4).....	-0.3V to 3.9V	LTC2259I.....	-40°C to 85°C
		Storage Temperature Range.....	-65°C to 150°C

**PIN CONFIGURATION**

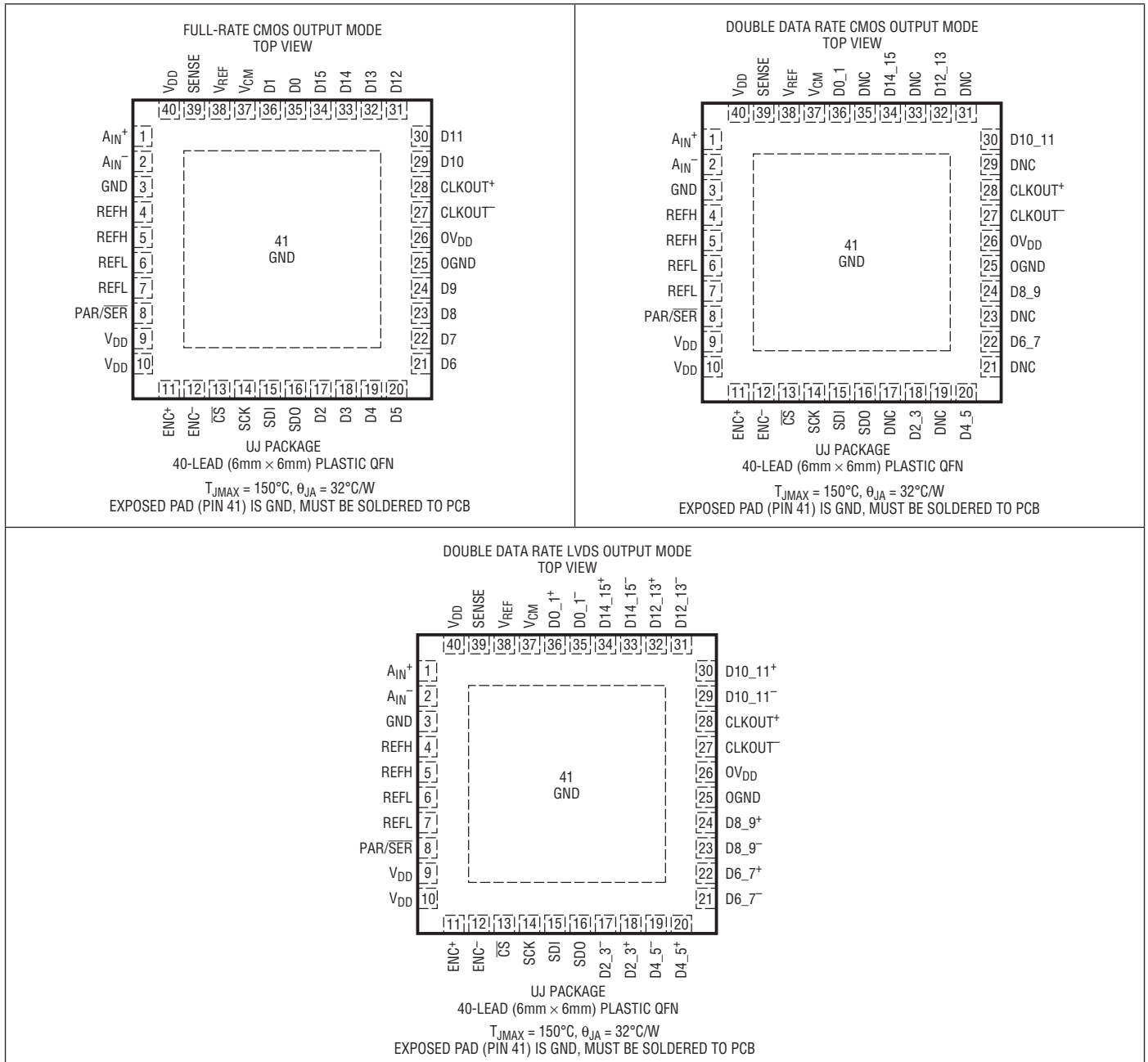

## ORDER INFORMATION

LEAD FREE FINISH	TAPE AND REEL	PART MARKING*	PACKAGE DESCRIPTION	TEMPERATURE RANGE
LTC2259CUJ-16#PBF	LTC2259CUJ-16#TRPBF	LTC2259UJ-16	40-Lead (6mm × 6mm) Plastic QFN	0°C to 70°C
LTC2259IUJ-16#PBF	LTC2259IUJ-16#TRPBF	LTC2259UJ-16	40-Lead (6mm × 6mm) Plastic QFN	-40°C to 85°C

Consult LTC Marketing for parts specified with wider operating temperature ranges. \*The temperature grade is identified by a label on the shipping container. Consult LTC Marketing for information on non-standard lead based finish parts.

For more information on lead free part marking, go to: <http://www.linear.com/leadfree/>

For more information on tape and reel specifications, go to: <http://www.linear.com/tapeandreel/>

## CONVERTER CHARACTERISTICS

The ● denotes the specifications which apply over the full operating temperature range, otherwise specifications are at  $T_A = 25^\circ\text{C}$ . (Note 5)

PARAMETER	CONDITIONS	MIN	TYP	MAX	UNITS	
Resolution (No Missing Codes)		●	16		Bits	
Integral Linearity Error	Differential Analog Input (Note 6)	●	-12	±4	12	LSB
Differential Linearity Error	Differential Analog Input	●	-1	±0.5	1.2	LSB
Offset Error	(Note 7)	●	-9	±1.5	9	mV
Gain Error	Internal Reference External Reference	●	-1.5	±1.5 ±0.4	1.5	%FS %FS
Offset Drift			±20		μV/°C	
Full-Scale Drift	Internal Reference External Reference		±30 ±10		ppm/°C ppm/°C	
Transition Noise	External Reference		5		LSB <sub>RMS</sub>	

## ANALOG INPUT

The ● denotes the specifications which apply over the full operating temperature range, otherwise specifications are at  $T_A = 25^\circ\text{C}$ . (Note 5)

SYMBOL	PARAMETER	CONDITIONS	MIN	TYP	MAX	UNITS	
$V_{IN}$	Analog Input Range ( $A_{IN}^+ - A_{IN}^-$ )	$1.7V < V_{DD} < 1.9V$	●	1 to 2		$V_{P-P}$	
$V_{INCM}$	Analog Input Common Mode ( $A_{IN}^+ + A_{IN}^-$ )/2	Differential Analog Input (Note 8)	●	$V_{CM} - 100mV$	$V_{CM}$ $V_{CM} + 100mV$	V	
$V_{SENSE}$	External Voltage Reference Applied to SENSE	External Reference Mode	●	0.625	1.250	1.300	V
$I_{INCM}$	Analog Input Common Mode Current	Per Pin, 80Msps		100		μA	
$I_{IN1}$	Analog Input Leakage Current	$0 < A_{IN}^+, A_{IN}^- < V_{DD}$ , No Encode	●	-1	1	μA	
$I_{IN2}$	PAR/SER Input Leakage Current	$0 < PAR/SER < V_{DD}$	●	-3	3	μA	
$I_{IN3}$	SENSE Input Leakage Current	$0.625 < SENSE < 1.3V$	●	-6	6	μA	
$t_{AP}$	Sample-and-Hold Acquisition Delay Time			0		ns	
$t_{JITTER}$	Sample-and-Hold Acquisition Delay Jitter			0.17		ps <sub>RMS</sub>	
CMRR	Analog Input Common Mode Rejection Ratio			80		dB	
BW-3B	Full-Power Bandwidth	Figure 6 Test Circuit		800		MHz	

## DYNAMIC ACCURACY

The ● denotes the specifications which apply over the full operating temperature range, otherwise specifications are at  $T_A = 25^\circ\text{C}$ .  $A_{IN} = -1\text{dBFS}$ . (Note 5)

SYMBOL	PARAMETER	CONDITIONS	MIN	TYP	MAX	UNITS
SNR	Signal-to-Noise Ratio	5MHz Input 70MHz Input 140MHz Input	●	70.9	73.1 72.9 72.4	dBFS dBFS dBFS

**DYNAMIC ACCURACY** The ● denotes the specifications which apply over the full operating temperature range, otherwise specifications are at  $T_A = 25^\circ\text{C}$ .  $A_{IN} = -1\text{dBFS}$ . (Note 5)

SYMBOL	PARAMETER	CONDITIONS	MIN	TYP	MAX	UNITS
SFDR	Spurious Free Dynamic Range 2nd or 3rd Harmonic	5MHz Input 70MHz Input 140MHz Input	●	79	88 85 82	dBFS dBFS dBFS
	Spurious Free Dynamic Range 4th Harmonic or Higher	5MHz Input 70MHz Input 140MHz Input	●	85	90 90 90	dBFS dBFS dBFS
S/(N+D)	Signal-to-Noise Plus Distortion Ratio	5MHz Input 70MHz Input 140MHz Input	●	70.4	72.9 72.6 72	dBFS dBFS dBFS

**INTERNAL REFERENCE CHARACTERISTICS** The ● denotes the specifications which apply over the full operating temperature range, otherwise specifications are at  $T_A = 25^\circ\text{C}$ . (Note 5)

PARAMETER	CONDITIONS	MIN	TYP	MAX	UNITS
$V_{CM}$ Output Voltage	$I_{OUT} = 0$	$0.5 \cdot V_{DD} - 25\text{mV}$	$0.5 \cdot V_{DD}$	$0.5 \cdot V_{DD} + 25\text{mV}$	V
$V_{CM}$ Output Temperature Drift			$\pm 25$		ppm/ $^\circ\text{C}$
$V_{CM}$ Output Resistance	$-600\mu\text{A} < I_{OUT} < 1\text{mA}$		4		$\Omega$
$V_{REF}$ Output Voltage	$I_{OUT} = 0$	1.225	1.250	1.275	V
$V_{REF}$ Output Temperature Drift			$\pm 25$		ppm/ $^\circ\text{C}$
$V_{REF}$ Output Resistance	$-400\mu\text{A} < I_{OUT} < 1\text{mA}$		7		$\Omega$
$V_{REF}$ Line Regulation	$1.7\text{V} < V_{DD} < 1.9\text{V}$		0.6		mV/V

**DIGITAL INPUTS AND OUTPUTS** The ● denotes the specifications which apply over the full operating temperature range, otherwise specifications are at  $T_A = 25^\circ\text{C}$ . (Note 5)

SYMBOL	PARAMETER	CONDITIONS	MIN	TYP	MAX	UNITS
<b>ENCODE INPUTS (ENC<sup>+</sup>, ENC<sup>-</sup>)</b>						
<b>Differential Encode Mode (ENC<sup>-</sup> Not Tied to GND)</b>						
$V_{ID}$	Differential Input Voltage	(Note 8)	●	0.2		V
$V_{ICM}$	Common Mode Input Voltage	Internally Set	●	1.2		V
		Externally Set (Note 8)	●		1.6	V
$V_{IN}$	Input Voltage Range	ENC <sup>+</sup> , ENC <sup>-</sup> to GND	●	0.2	3.6	V
$R_{IN}$	Input Resistance	(See Figure 10)		10		k $\Omega$
$C_{IN}$	Input Capacitance	(Note 8)		3.5		pF
<b>Single-Ended Encode Mode (ENC<sup>-</sup> Tied to GND)</b>						
$V_{IH}$	High Level Input Voltage	$V_{DD} = 1.8\text{V}$	●	1.2		V
$V_{IL}$	Low Level Input Voltage	$V_{DD} = 1.8\text{V}$	●		0.6	V
$V_{IN}$	Input Voltage Range	ENC <sup>+</sup> to GND	●	0	3.6	V
$R_{IN}$	Input Resistance	(See Figure 11)		30		k $\Omega$
$C_{IN}$	Input Capacitance	(Note 8)		3.5		pF
<b>DIGITAL INPUTS (CS<sup>-</sup>, SDI, SCK)</b>						
$V_{IH}$	High Level Input Voltage	$V_{DD} = 1.8\text{V}$	●	1.3		V
$V_{IL}$	Low Level Input Voltage	$V_{DD} = 1.8\text{V}$	●		0.6	V
$I_{IN}$	Input Current	$V_{IN} = 0\text{V}$ to 3.6V	●	-10	10	$\mu\text{A}$
$C_{IN}$	Input Capacitance	(Note 8)		3		pF

## DIGITAL INPUTS AND OUTPUTS

The ● denotes the specifications which apply over the full operating temperature range, otherwise specifications are at  $T_A = 25^\circ\text{C}$ . (Note 5)

SYMBOL	PARAMETER	CONDITIONS		MIN	TYP	MAX	UNITS
<b>SDO OUTPUT (Open-Drain Output. Requires 2k Pull-Up Resistor if SDO is Used)</b>							
$R_{OL}$	Logic Low Output Resistance to GND	$V_{DD} = 1.8\text{V}$ , $SDO = 0\text{V}$			200		$\Omega$
$I_{OH}$	Logic High Output Leakage Current	$SDO = 0\text{V}$ to $3.6\text{V}$	●	-10		10	$\mu\text{A}$
$C_{OUT}$	Output Capacitance	(Note 8)			4		$\text{pF}$
<b>DIGITAL DATA OUTPUTS (CMOS MODES: FULL DATA RATE AND DOUBLE-DATA RATE)</b>							
<b><math>OV_{DD} = 1.8\text{V}</math></b>							
$V_{OH}$	High Level Output Voltage	$I_O = -500\mu\text{A}$	●	1.750	1.790		V
$V_{OL}$	Low Level Output Voltage	$I_O = 500\mu\text{A}$	●		0.010	0.050	V
<b><math>OV_{DD} = 1.5\text{V}</math></b>							
$V_{OH}$	High Level Output Voltage	$I_O = -500\mu\text{A}$			1.488		V
$V_{OL}$	Low Level Output Voltage	$I_O = 500\mu\text{A}$			0.010		V
<b><math>OV_{DD} = 1.2\text{V}</math></b>							
$V_{OH}$	High Level Output Voltage	$I_O = -500\mu\text{A}$			1.185		V
$V_{OL}$	Low Level Output Voltage	$I_O = 500\mu\text{A}$			0.010		V
<b>DIGITAL DATA OUTPUTS (LVDS MODE)</b>							
$V_{OD}$	Differential Output Voltage	100 $\Omega$ Differential Load, 3.5mA Mode 100 $\Omega$ Differential Load, 1.75mA Mode	●	247	350 175	454	mV mV
$V_{OS}$	Common Mode Output Voltage	100 $\Omega$ Differential Load, 3.5mA Mode 100 $\Omega$ Differential Load, 1.75mA Mode	●	1.125	1.250 1.250	1.375	V V
$R_{TERM}$	On-Chip Termination Resistance	Termination Enabled, $OV_{DD} = 1.8\text{V}$			100		$\Omega$

## POWER REQUIREMENTS

The ● denotes the specifications which apply over the full operating temperature range, otherwise specifications are at  $T_A = 25^\circ\text{C}$ . (Note 9)

SYMBOL	PARAMETER	CONDITIONS		MIN	TYP	MAX	UNITS
<b>CMOS Output Modes: Full Data Rate and Double-Data Rate</b>							
$V_{DD}$	Analog Supply Voltage	(Note 10)	●	1.7	1.8	1.9	V
$OV_{DD}$	Output Supply Voltage	(Note 10)	●	1.1		1.9	V
$I_{VDD}$	Analog Supply Current	DC Input Sine Wave Input	●		49.2 50.2	58.1	$\text{mA}$ $\text{mA}$
$I_{OVDD}$	Digital Supply Current	Sine Wave Input, $OV_{DD}=1.2\text{V}$			2.5		$\text{mA}$
$P_{DISS}$	Power Dissipation	DC Input Sine Wave Input, $OV_{DD}=1.2\text{V}$	●		89 93	105	$\text{mW}$ $\text{mW}$
<b>LVDS Output Mode</b>							
$V_{DD}$	Analog Supply Voltage	(Note 10)	●	1.7	1.8	1.9	V
$OV_{DD}$	Output Supply Voltage	(Note 10)	●	1.7		1.9	V
$I_{VDD}$	Analog Supply Current	Sine Wave Input	●		53.8	63.5	$\text{mA}$
$I_{OVDD}$	Digital Supply Current ( $OV_{DD} = 1.8\text{V}$ )	Sine Input, 1.75mA Mode Sine Input, 3.5mA Mode	● ●		20.7 40.5	26 47.8	$\text{mA}$ $\text{mA}$
$P_{DISS}$	Power Dissipation	Sine Input, 1.75mA Mode Sine Input, 3.5mA Mode	● ●		134 170	161 201	$\text{mW}$ $\text{mW}$
<b>All Output Modes</b>							
$P_{SLEEP}$	Sleep Mode Power				0.5		$\text{mW}$
$P_{NAP}$	Nap Mode Power				9		$\text{mW}$
$P_{DIFFCLK}$	Power Increase with Differential Encode Mode Enabled (No increase for Nap or Sleep Modes)				10		$\text{mW}$

225916f

## TIMING CHARACTERISTICS

The ● denotes the specifications which apply over the full operating temperature range, otherwise specifications are at  $T_A = 25^\circ\text{C}$ . (Note 5)

SYMBOL	PARAMETER	CONDITIONS		MIN	TYP	MAX	UNITS
$f_S$	Sampling Frequency	(Note 10)	●	1		80	MHz
$t_L$	ENC Low Time (Note 8)	Duty Cycle Stabilizer Off	●	5.93	6.25	500	ns
		Duty Cycle Stabilizer On	●	2.00	6.25	500	ns
$t_H$	ENC High Time (Note 8)	Duty Cycle Stabilizer Off	●	5.93	6.25	500	ns
		Duty Cycle Stabilizer On	●	2.00	6.25	500	ns
$t_{AP}$	Sample-and-Hold Acquisition Delay Time			0			ns

### Digital Data Outputs (CMOS Modes: Full Data Rate and Double-Data Rate)

$t_D$	ENC to Data Delay	$C_L = 5\text{pF}$ (Note 8)	●	1.1	1.7	3.1	ns
$t_C$	ENC to CLKOUT Delay	$C_L = 5\text{pF}$ (Note 8)	●	1	1.4	2.6	ns
$t_{SKEW}$	DATA to CLKOUT Skew	$t_D - t_C$ (Note 8)	●	0	0.3	0.6	ns
	Pipeline Latency	Full Data Rate Mode Double-Data Rate Mode			5.0 5.5		Cycles Cycles

### Digital Data Outputs (LVDS Mode)

$t_D$	ENC to Data Delay	$C_L = 5\text{pF}$ (Note 8)	●	1.1	1.8	3.2	ns
$t_C$	ENC to CLKOUT Delay	$C_L = 5\text{pF}$ (Note 8)	●	1	1.5	2.7	ns
$t_{SKEW}$	DATA to CLKOUT Skew	$t_D - t_C$ (Note 8)	●	0	0.3	0.6	ns
	Pipeline Latency				5.5		Cycles

### SPI Port Timing (Note 8)

$t_{SCK}$	SCK Period	Write Mode	●	40			ns
		Readback Mode, $C_{SDO} = 20\text{pF}$ , $R_{PULLUP} = 2\text{k}$	●	250			ns
$t_S$	$\overline{CS}$ to SCK Setup Time		●	5			ns
$t_H$	SCK to $\overline{CS}$ Setup Time		●	5			ns
$t_{DS}$	SDI Setup Time		●	5			ns
$t_{DH}$	SDI Hold Time		●	5			ns
$t_{DO}$	SCK Falling to SDO Valid	Readback Mode, $C_{SDO} = 20\text{pF}$ , $R_{PULLUP} = 2\text{k}$	●			125	ns

**Note 1:** Stresses beyond those listed under Absolute Maximum Ratings may cause permanent damage to the device. Exposure to any Absolute Maximum Rating condition for extended periods may affect device reliability and lifetime.

**Note 2:** All voltage values are with respect to GND with GND and OGND shorted (unless otherwise noted).

**Note 3:** When these pin voltages are taken below GND or above  $V_{DD}$ , they will be clamped by internal diodes. This product can handle input currents of greater than 100mA below GND or above  $V_{DD}$  without latchup.

**Note 4:** When these pin voltages are taken below GND they will be clamped by internal diodes. When these pin voltages are taken above  $V_{DD}$  they will not be clamped by internal diodes. This product can handle input currents of greater than 100mA below GND without latchup.

**Note 5:**  $V_{DD} = 0V$ ,  $V_{DD} = 1.8V$ ,  $f_{SAMPLE} = 80\text{MHz}$ , LVDS outputs with internal termination disabled, differential  $ENC^+/ENC^- = 2V_{P-P}$  sine wave, input range =  $2V_{P-P}$  with differential drive, unless otherwise noted.

**Note 6:** Integral nonlinearity is defined as the deviation of a code from a best fit straight line to the transfer curve. The deviation is measured from the center of the quantization band.

**Note 7:** Offset error is the offset voltage measured from  $-0.5$  LSB when the output code flickers between 0000 0000 0000 0000 and 1111 1111 1111 1111 in 2's complement output mode.

**Note 8:** Guaranteed by design, not subject to test.

**Note 9:**  $V_{DD} = 1.8V$ ,  $f_{SAMPLE} = 80\text{MHz}$ ,  $ENC^+ =$  single-ended 1.8V square wave,  $ENC^- = 0V$ , input range =  $2V_{P-P}$  with differential drive, 5pF load on each digital output unless otherwise noted.

**Note 10:** Recommended operating conditions.

# TIMING DIAGRAMS

**Full-Rate CMOS Output Mode Timing**  
 All Outputs Are Single-Ended and Have CMOS Levels

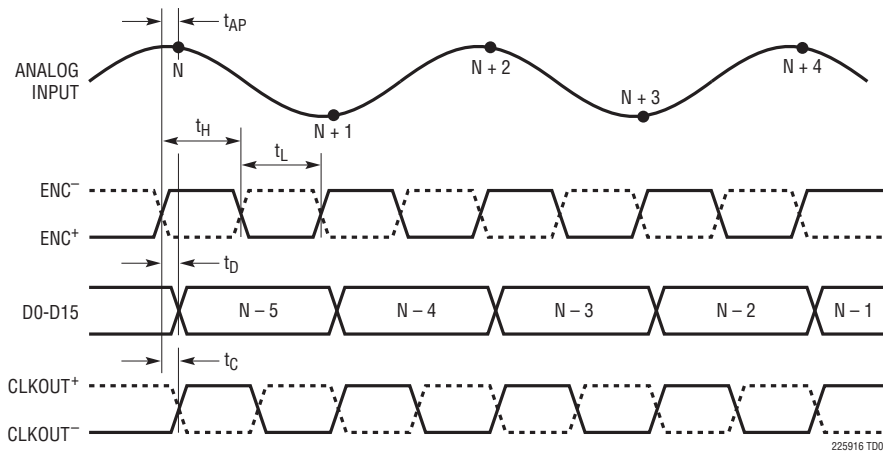

**Double-Data Rate CMOS Output Mode Timing**  
 All Outputs Are Single-Ended and Have CMOS Levels

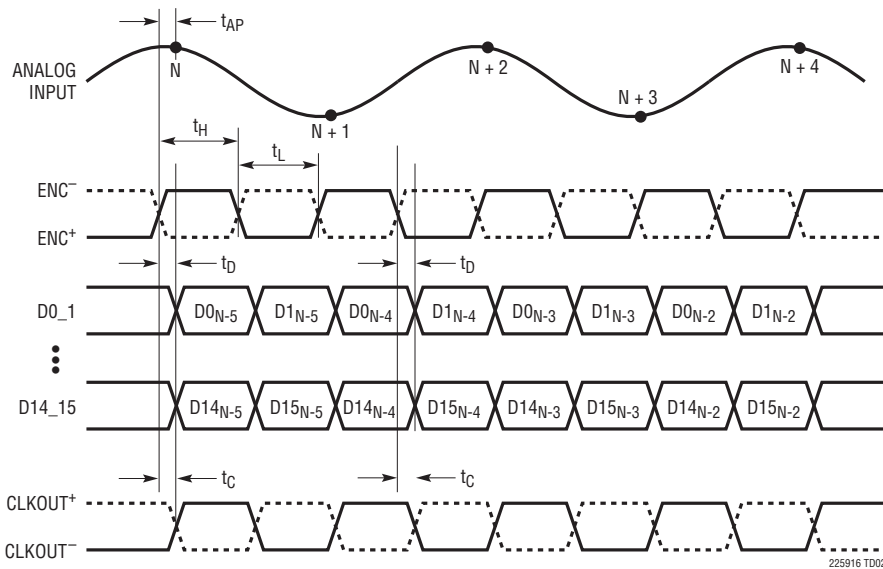

# TIMING DIAGRAMS

**Double-Data Rate LVDS Output Mode Timing**  
 All Outputs Are Differential and Have LVDS Levels

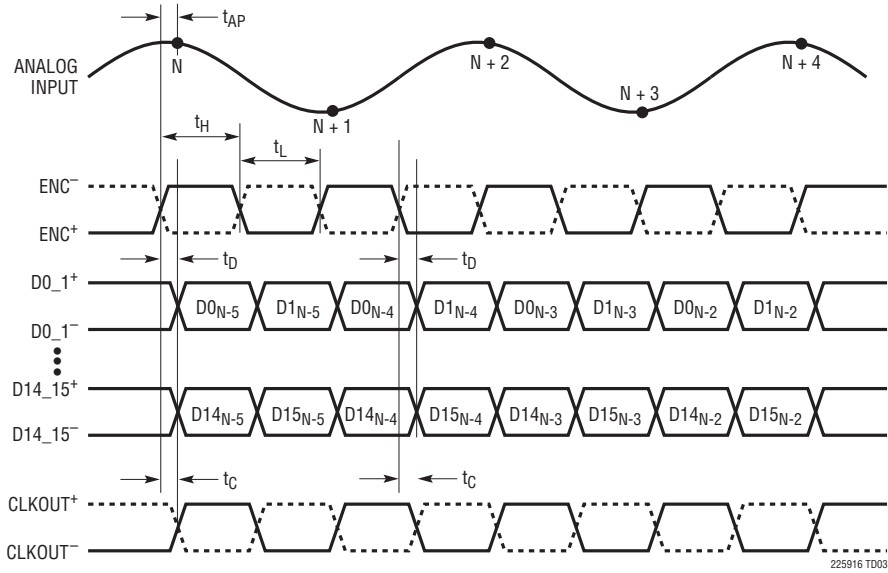

**SPI Port Timing (Readback Mode)**

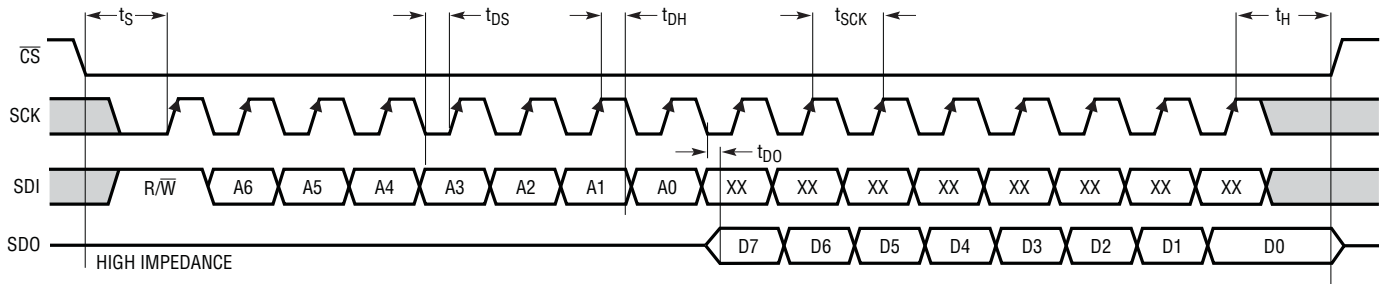

**SPI Port Timing (Write Mode)**

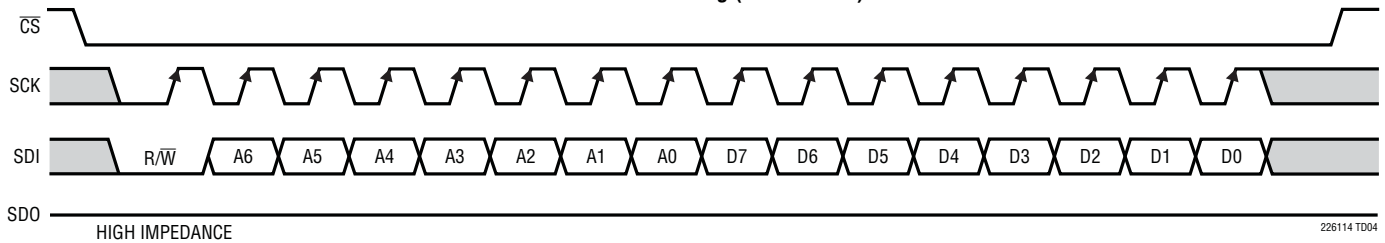



# TYPICAL PERFORMANCE CHARACTERISTICS

**LTC2259-16: Integral Non-Linearity (INL)**

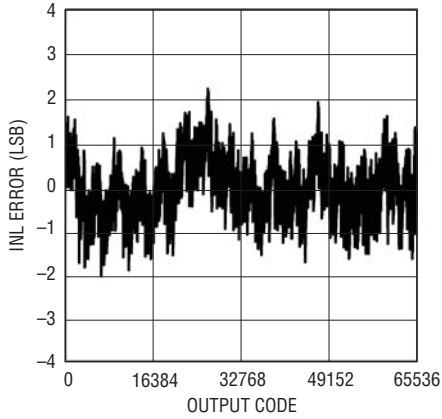

225916 G01

**LTC2259-16: Differential Non-Linearity (DNL)**

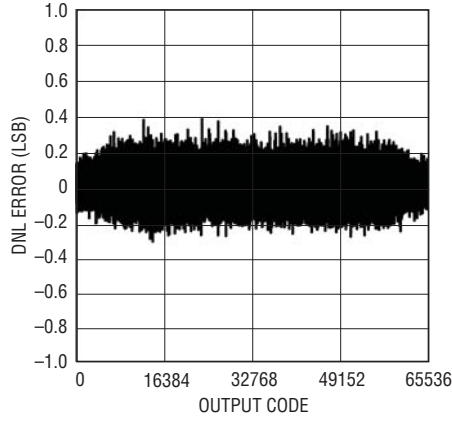

225916 G02

**LTC2259-16: 8k Point FFT,  $f_{IN} = 5\text{MHz} -1\text{dBFS}$ , 80Mps**

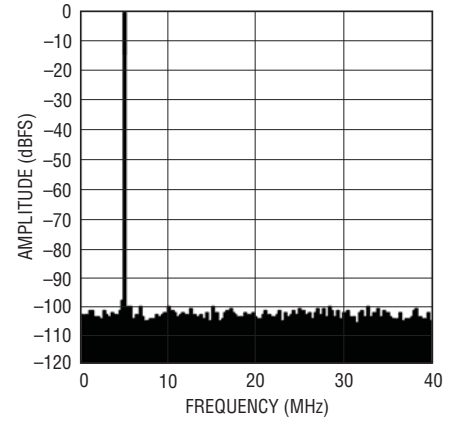

225916 G03

**LTC2259-16: 8k Point FFT,  $f_{IN} = 30\text{MHz} -1\text{dBFS}$ , 80Mps**

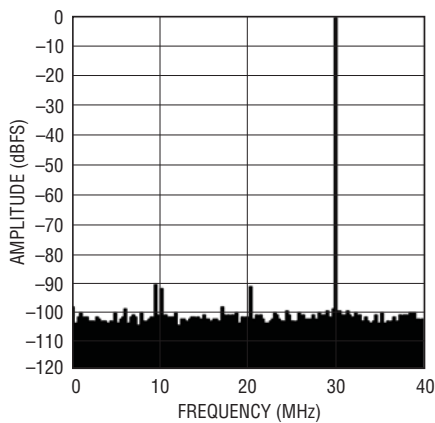

225916 G04

**LTC2259-16: 8k Point FFT,  $f_{IN} = 70\text{MHz} -1\text{dBFS}$ , 80Mps**

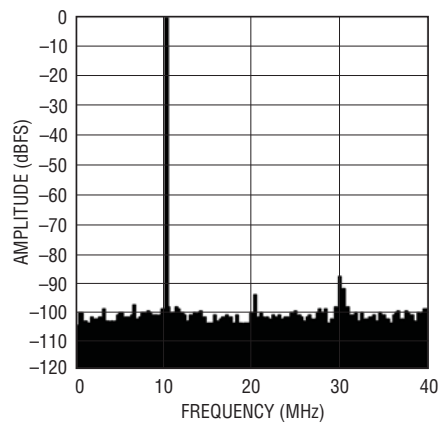

225916 G05

**LTC2259-16: 8k Point FFT,  $f_{IN} = 140\text{MHz} -1\text{dBFS}$ , 80Mps**

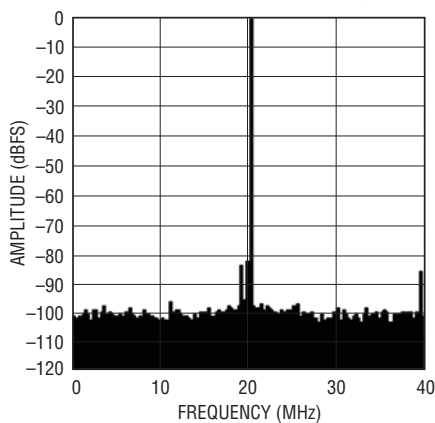

225916 G06

**LTC2259-16: 8k Point 2-Tone FFT,  $f_{IN} = 70\text{MHz}, 75\text{MHz}, -1\text{dBFS}$ , 80Mps**

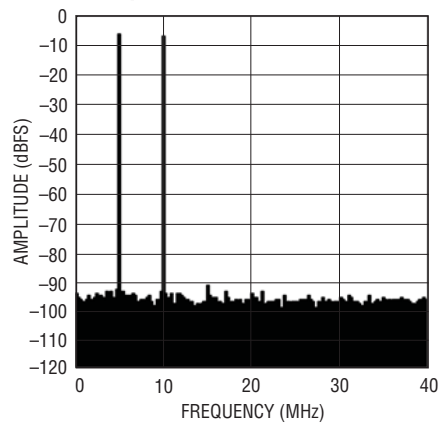

225916 G07

## TYPICAL PERFORMANCE CHARACTERISTICS

**LTC2259-16: SNR vs Input Frequency, -1dBFS, 2V Range, 80MSPS**

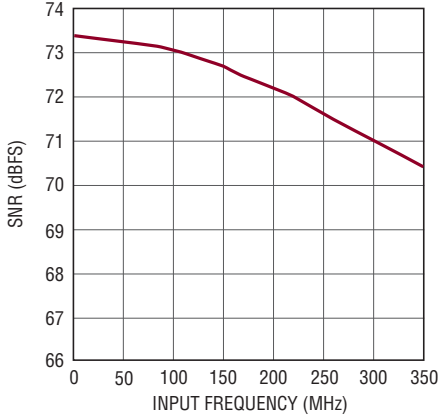

225916 G08

**LTC2259-16: SFDR vs Input Frequency, -1dBFS, 2V Range, 80MSPS**

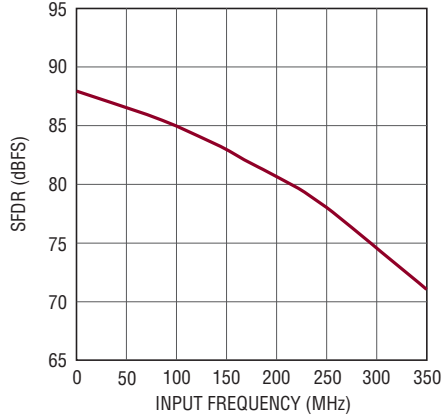

225916 G09

**LTC2259-16: SFDR vs Input Level,  $f_{IN} = 70\text{MHz}$ , 2V Range, 80MSPS**

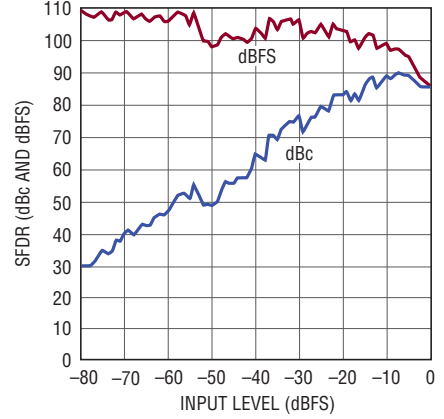

225916 G10

**LTC2259-16:  $I_{VDD}$  vs Sample Rate, 5MHz Sine Wave Input, -1dBFS**

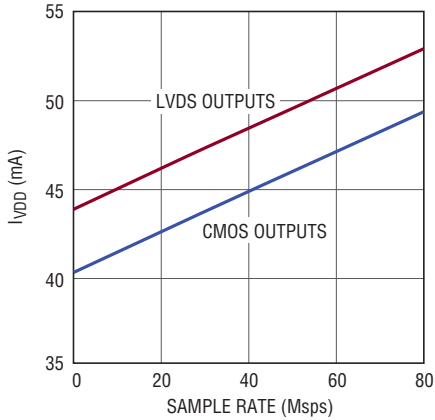

225916 G11

**LTC2259-16:  $I_{OVD}$  vs Sample Rate, 5MHz Sine Wave Input, -1dBFS, 5pF on Each Data Output**

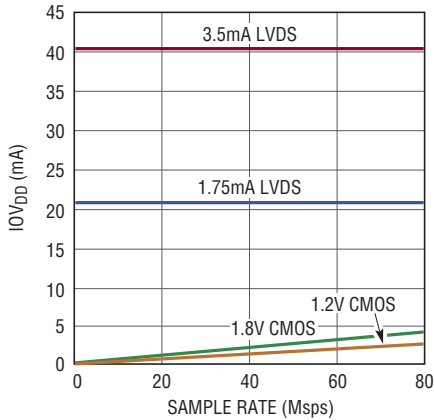

225916 G12

**LTC2259-16: SNR vs SENSE,  $f_{IN} = 5\text{MHz}$ , -1dBFS**

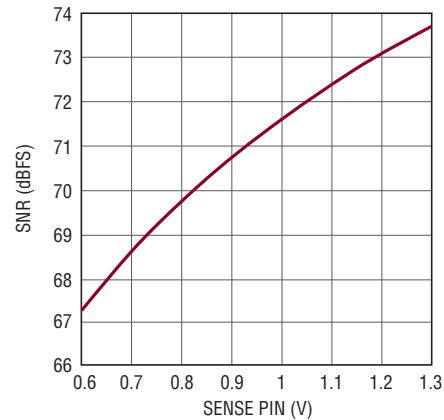

225916 G13

## PIN FUNCTIONS

### PINS THAT ARE THE SAME FOR ALL DIGITAL OUTPUT MODES

**A<sub>IN</sub><sup>+</sup> (Pin 1):** Positive Differential Analog Input.

**A<sub>IN</sub><sup>-</sup> (Pin 2):** Negative Differential Analog Input.

**GND (Pin 3, Exposed Pad Pin 41):** ADC Power Ground.

**REFH (Pins 4, 5):** ADC High Reference. Bypass to Pins 6, 7 with a 2.2μF ceramic capacitor and to ground with a 0.1μF ceramic capacitor.

**REFL (Pins 6, 7):** ADC Low Reference. Bypass to Pins 4, 5 with a 2.2μF ceramic capacitor and to ground with a 0.1μF ceramic capacitor.

**PAR/SER (Pin 8):** Programming Mode Selection Pin. Connect to ground to enable the serial programming mode.  $\overline{CS}$ , SCK, SDI, SDO become a serial interface that control the A/D operating modes. Connect to  $V_{DD}$  to enable the parallel programming mode where  $\overline{CS}$ , SCK, SDI become parallel logic inputs that control a reduced set of the A/D operating modes. PAR/SER should be connected directly to ground or the  $V_{DD}$  of the part and not be driven by a logic signal.

**$V_{DD}$  (Pins 9, 10, 40):** 1.8V Analog Power Supply. Bypass to ground with 0.1μF ceramic capacitors. Pins 9 and 10 can share a bypass capacitor.

**ENC<sup>+</sup> (Pin 11):** Encode Input. Conversion starts on the rising edge.

**ENC<sup>-</sup> (Pin 12):** Encode Complement Input. Conversion starts on the falling edge.

**$\overline{CS}$  (Pin 13):** In serial programming mode, (PAR/SER = 0V),  $\overline{CS}$  is the serial interface chip select input. When  $\overline{CS}$  is low, SCK is enabled for shifting data on SDI into the mode control registers. In the parallel programming mode (PAR/SER =  $V_{DD}$ ),  $\overline{CS}$  controls the clock duty cycle stabilizer. When  $\overline{CS}$  is low, the clock duty cycle stabilizer is turned off. When  $\overline{CS}$  is high, the clock duty cycle stabilizer is turned on.  $\overline{CS}$  can be driven with 1.8V to 3.3V logic.

**SCK (Pin 14):** In serial programming mode, (PAR/SER = 0V), SCK is the serial interface clock input. In the parallel programming mode (PAR/SER =  $V_{DD}$ ), SCK controls the digital output mode. When SCK is low, the full-rate CMOS output mode is enabled. When SCK is high, the double-data rate LVDS output mode (with 3.5mA output current) is enabled. SCK can be driven with 1.8V to 3.3V logic.

**SDI (Pin 15):** In serial programming mode, (PAR/SER = 0V), SDI is the serial interface data input. Data on SDI is clocked into the mode control registers on the rising edge of SCK. In the parallel programming mode (PAR/SER =  $V_{DD}$ ), SDI can be used to power down the part. When SDI is low, the part operates normally. When SDI is high, the part enters sleep mode. SDI can be driven with 1.8V to 3.3V logic.

**SDO (Pin 16):** In serial programming mode, (PAR/SER = 0V), SDO is the optional serial interface data output. Data on SDO is read back from the mode control registers and can be latched on the falling edge of SCK. SDO is an open-drain NMOS output that requires an external 2k pull-up resistor to 1.8V-3.3V. If read back from the mode control registers is not needed, the pull-up resistor is not necessary and SDO can be left unconnected. In the parallel programming mode (PAR/SER =  $V_{DD}$ ), SDO is not used and should not be connected.

**OGND (Pin 25):** Output Driver Ground.

**$OV_{DD}$  (Pin 26):** Output Driver Supply. Bypass to ground with a 0.1μF ceramic capacitor.

**$V_{CM}$  (Pin 37):** Common Mode Bias Output, Nominally Equal to  $V_{DD}/2$ .  $V_{CM}$  should be used to bias the common mode of the analog inputs. Bypass to ground with a 0.1μF ceramic capacitor.

**$V_{REF}$  (Pin 38):** Reference Voltage Output. Bypass to ground with a 1μF ceramic capacitor, nominally 1.25V.

**SENSE (Pin 39):** Reference Programming Pin. Connecting SENSE to  $V_{DD}$  selects the internal reference and a ±1V input range. Connecting SENSE to ground selects the internal reference and a ±0.5V input range. An external reference between 0.625V and 1.3V applied to SENSE selects an input range of  $\pm 0.8 \cdot V_{SENSE}$ .

## PIN FUNCTIONS

### FULL-RATE CMOS OUTPUT MODE

**All Pins Below Have CMOS Output Levels (OGND to  $OV_{DD}$ )**

**D0 to D15 (Pins 35, 36, 17-24, 29-34):** Digital Outputs. D15 is the MSB. D0 is the LSB.

**CLKOUT<sup>-</sup> (Pin 27):** Inverted Version of CLKOUT<sup>+</sup>.

**CLKOUT<sup>+</sup> (Pin 28):** Data Output Clock. The digital outputs normally transition at the same time as the falling edge of CLKOUT<sup>+</sup>. The phase of CLKOUT<sup>+</sup> can also be delayed relative to the digital outputs by programming the mode control registers.

### DOUBLE-DATA RATE CMOS OUTPUT MODE

**All Pins Below Have CMOS Output Levels (OGND to  $OV_{DD}$ )**

**D0\_1 to D14\_15 (Pins 36,18, 20, 22, 24, 30, 32, 34):** Double-Data Rate Digital Outputs. Two data bits are multiplexed onto each output pin. The even data bits (D0, D2, D4, D6, D8, D10, D12, D14) appear when CLKOUT<sup>+</sup> is low. The odd data bits (D1, D3, D5, D7, D9, D11, D13, D15) appear when CLKOUT<sup>+</sup> is high.

**CLKOUT<sup>-</sup> (Pin 27):** Inverted Version of CLKOUT<sup>+</sup>.

**CLKOUT<sup>+</sup> (Pin 28):** Data Output Clock. The digital outputs normally transition at the same time as the falling and rising edges of CLKOUT<sup>+</sup>. The phase of CLKOUT<sup>+</sup> can also be delayed relative to the digital outputs by programming the mode control registers.

**DNC (Pins 17, 19, 21, 23, 29, 31, 33, 35):** Do not connect these pins.

### DOUBLE-DATA RATE LVDS OUTPUT MODE

**All Pins Below Have LVDS Output Levels. The Output Current Level is Programmable. There is an Optional Internal 100Ω Termination Resistor Between the Pins of Each LVDS Output Pair.**

**D0\_1<sup>-</sup>/D0\_1<sup>+</sup> to D14\_15<sup>-</sup>/D14\_15<sup>+</sup> (Pins 35/36, 17/18, 19/20, 21/22, 23/24, 29/30, 31/32, 33/34):** Double-Data Rate Digital Outputs. Two data bits are multiplexed onto each differential output pair. The even data bits (D0, D2, D4, D6, D8, D10, D12, D14) appear when CLKOUT<sup>+</sup> is low. The odd data bits (D1, D3, D5, D7, D9, D11, D13, D15) appear when CLKOUT<sup>+</sup> is high.

**CLKOUT<sup>-</sup>/CLKOUT<sup>+</sup> (Pins 27/28):** Data Output Clock. The digital outputs normally transition at the same time as the falling and rising edges of CLKOUT<sup>+</sup>. The phase of CLKOUT<sup>+</sup> can also be delayed relative to the digital outputs by programming the mode control registers.



## APPLICATIONS INFORMATION

### INPUT DRIVE CIRCUITS

#### Input Filtering

If possible, there should be an RC lowpass filter right at the analog inputs. This lowpass filter isolates the drive circuitry from the A/D sample-and-hold switching, and also limits wideband noise from the drive circuitry. Figure 3 shows an example of an input RC filter. The RC component values should be chosen based on the application's input frequency.

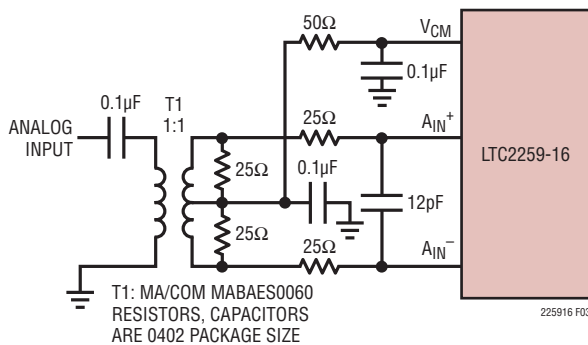

**Figure 3. Analog Input Circuit Using a Transformer.**  
Recommended for Input Frequencies from 5MHz to 70MHz

#### Transformer-Coupled Circuits

Figure 3 shows the analog input being driven by an RF transformer with a center-tapped secondary. The center tap is biased with  $V_{CM}$ , setting the A/D input at its optimal DC level. At higher input frequencies a transmission line balun transformer (Figures 4 to 6) has better balance, resulting in lower A/D distortion.

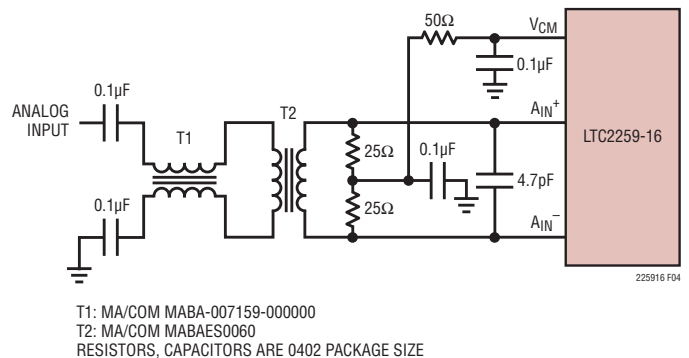

**Figure 4. Recommended Front-End Circuit for**  
Input Frequencies from 70MHz to 170MHz

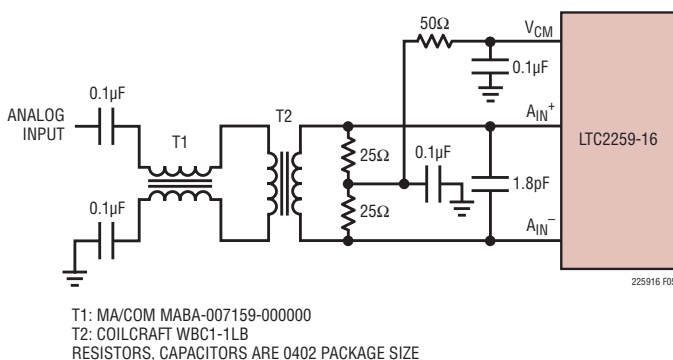

**Figure 5. Recommended Front-End Circuit for**  
Input Frequencies from 170MHz to 270MHz

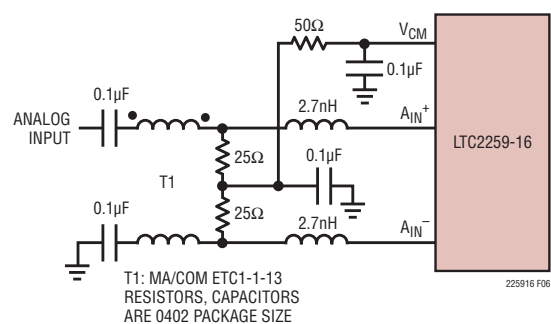

**Figure 6. Recommended Front-End Circuit for**  
Input Frequencies Above 270MHz

## APPLICATIONS INFORMATION

### Amplifier Circuits

Figure 7 shows the analog input being driven by a high speed differential amplifier. The output of the amplifier is AC-coupled to the A/D so the amplifier's output common mode voltage can be optimally set to minimize distortion.

At very high frequencies an RF gain block will often have lower distortion than a differential amplifier. If the gain block is single-ended, then a transformer circuit (Figures 4 to 6) should convert the signal to differential before driving the A/D.

### Reference

The LTC2259-16 has an internal 1.25V voltage reference. For a 2V input range using the internal reference, connect SENSE to  $V_{DD}$ . For a 1V input range using the internal reference, connect SENSE to ground. For a 2V input range with an external reference, apply a 1.25V reference voltage to SENSE (Figure 9.)

The input range can be adjusted by applying a voltage to SENSE that is between 0.625V and 1.300V. The input range will then be  $1.6 \cdot V_{SENSE}$ .

The  $V_{REF}$ , REFH and REFL pins should be bypassed as shown in Figure 8. The  $0.1\mu\text{F}$  capacitor between REFH and REFL should be as close to the pins as possible (not on the back side of the circuit board).

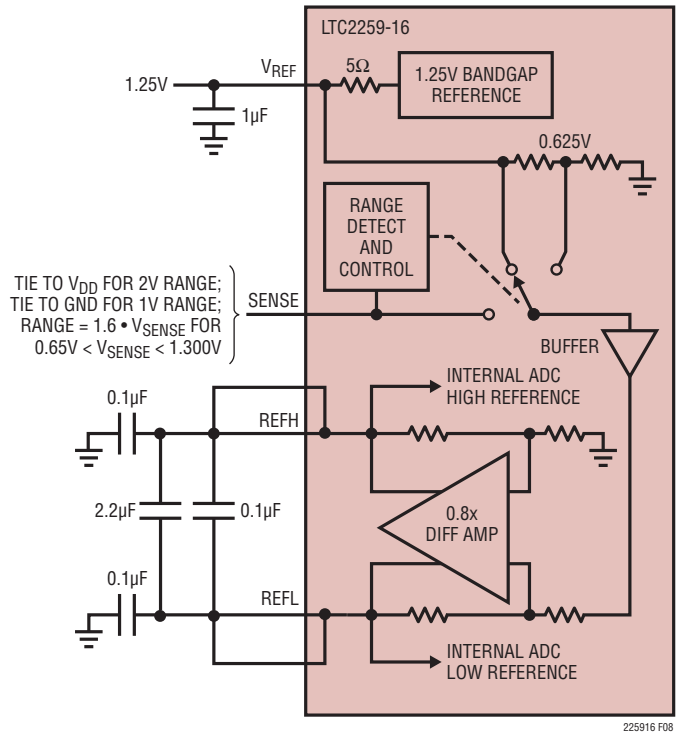

Figure 8. Reference Circuit

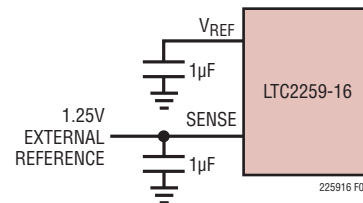

Figure 9. Using an External 1.25V Reference

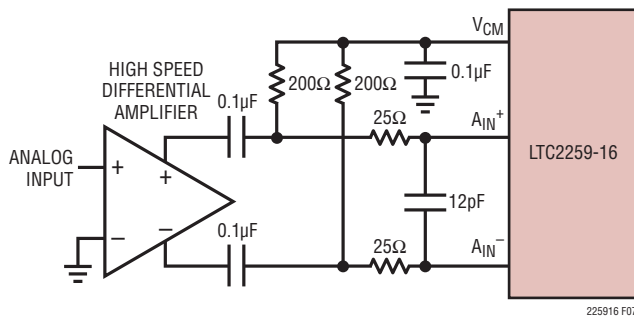

Figure 7. Front-End Circuit Using a High Speed Differential Amplifier

## APPLICATIONS INFORMATION

### Encode Input

The signal quality of the encode inputs strongly affects the A/D noise performance. The encode inputs should be treated as analog signals—do not route them next to digital traces on the circuit board. There are two modes of operation for the encode inputs: the differential encode mode (Figure 10) and the single-ended encode mode (Figure 11).

The differential encode mode is recommended for sinusoidal, PECL or LVDS encode inputs (Figures 12, 13). The encode inputs are internally biased to 1.2V through 10k equivalent resistance. The encode inputs can be taken above  $V_{DD}$  (up to 3.6V), and the common mode range is from 1.1V to 1.6V. In the differential encode mode,  $ENC^-$  should stay at least 200mV above ground to avoid falsely triggering the single-ended encode mode. For good jitter performance  $ENC^+$  and  $ENC^-$  should have fast rise and fall times.

The single-ended encode mode should be used with CMOS encode inputs. To select this mode,  $ENC^-$  is connected to ground and  $ENC^+$  is driven with a square wave encode input.  $ENC^+$  can be taken above  $V_{DD}$  (up to 3.6V) so 1.8V to 3.3V CMOS logic levels can be used. The  $ENC^+$  threshold is 0.9V. For good jitter performance  $ENC^+$  should have fast rise and fall times.

### Clock Duty Cycle Stabilizer

For good performance the encode signal should have a 50% ( $\pm 5\%$ ) duty cycle. If the optional clock duty cycle stabilizer circuit is enabled, the encode duty cycle can vary from 30% to 70% and the duty cycle stabilizer will maintain a constant 50% internal duty cycle. If the encode signal changes frequency or is turned off, the duty cycle stabilizer circuit requires one hundred clock cycles to lock onto the input clock. The duty cycle stabilizer is enabled by mode control register A2 (serial programming mode), or by  $\overline{CS}$  (parallel programming mode).

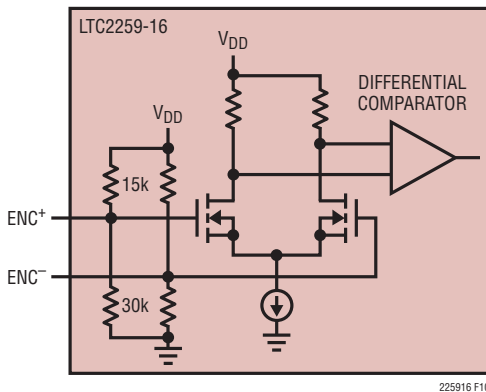

Figure 10. Equivalent Encode Input Circuit for Differential Encode Mode

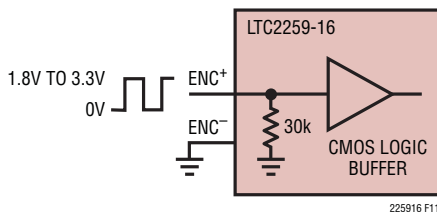

Figure 11. Equivalent Encode Input Circuit for Single-Ended Encode Mode

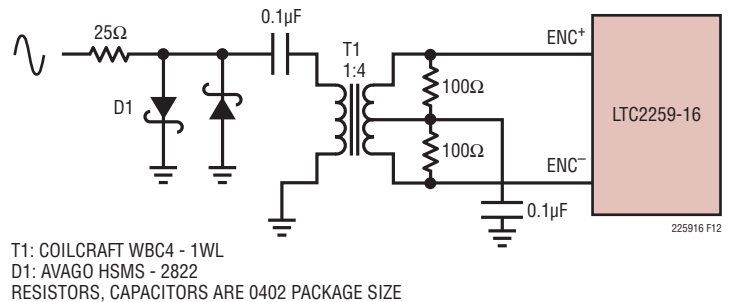

Figure 12. Sinusoidal Encode Drive

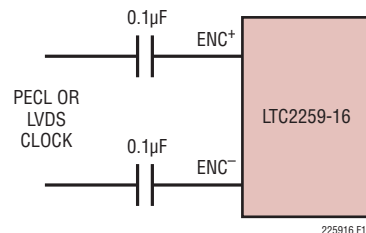

Figure 13. PECL or LVDS Encode Drive



## APPLICATIONS INFORMATION

For applications where the sample rate needs to be changed quickly, the clock duty cycle stabilizer can be disabled. If the duty cycle stabilizer is disabled, care should be taken to make the sampling clock have a 50% ( $\pm 5\%$ ) duty cycle. The duty cycle stabilizer should not be used below 5MSPS.

### DIGITAL OUTPUTS

#### Digital Output Modes

The LTC2259-16 can operate in three digital output modes: full-rate CMOS, double-data rate CMOS (to halve the number of output lines), or double-data rate LVDS (to reduce digital noise in the system). The output mode is set by mode control register A3 (serial programming mode), or by SCK (parallel programming mode). Note that double-data rate CMOS cannot be selected in the parallel programming mode.

#### Full-Rate CMOS Mode

In full-rate CMOS mode the 16 digital outputs (D0-D15), and the data output clocks (CLKOUT<sup>+</sup>, CLKOUT<sup>-</sup>) have CMOS output levels. The outputs are powered by OV<sub>DD</sub> and OGND which are isolated from the A/D core power and ground. OV<sub>DD</sub> can range from 1.1V to 1.9V, allowing 1.2V through 1.8V CMOS logic outputs.

For good performance, the digital outputs should drive minimal capacitive loads. If the load capacitance is larger than 10pF a digital buffer should be used.

#### Double-Data Rate CMOS Mode

In double-data rate CMOS mode, two data bits are multiplexed and output on each data pin. This reduces the number of data lines by eight, simplifying board routing and reducing the number of input pins needed to receive the data. The 8 digital outputs (D0\_1, D2\_3, D4\_5, D6\_7, D8\_9, D10\_11, D12\_13, D14\_15), and the data output clocks (CLKOUT<sup>+</sup>, CLKOUT<sup>-</sup>) have CMOS output levels. The outputs are powered by OV<sub>DD</sub> and OGND which are isolated from the A/D core power and ground. OV<sub>DD</sub> can range from 1.1V to 1.9V, allowing 1.2V through 1.8V CMOS logic outputs.

For good performance the digital outputs should drive minimal capacitive loads. If the load capacitance is larger than 10pF a digital buffer should be used.

#### Double-Data Rate LVDS Mode

In double-data rate LVDS mode, two data bits are multiplexed and output on each differential output pair. There are 8 LVDS output pairs (D0\_1<sup>+</sup>/D0\_1<sup>-</sup> through D14\_15<sup>+</sup>/D14\_15<sup>-</sup>) for the digital output data. The data output clock (CLKOUT<sup>+</sup>/CLKOUT<sup>-</sup>) has an LVDS output pair.

By default the outputs are standard LVDS levels: 3.5mA output current and a 1.25V output common mode voltage. An external 100 $\Omega$  differential termination resistor is required for each LVDS output pair. The termination resistors should be located as close as possible to the LVDS receiver.

The outputs are powered by OV<sub>DD</sub> and OGND which are isolated from the A/D core power and ground. In LVDS mode, OV<sub>DD</sub> must be 1.8V.

#### Programmable LVDS Output Current

In LVDS mode, the default output driver current is 3.5mA. This current can be adjusted by serially programming mode control register A3. Available current levels are 1.75mA, 2.1mA, 2.5mA, 3mA, 3.5mA, 4mA and 4.5mA.

#### Optional LVDS Driver Internal Termination

In most cases using just an external 100 $\Omega$  termination resistor will give excellent LVDS signal integrity. In addition, an optional internal 100 $\Omega$  termination resistor can be enabled by serially programming mode control register A3. The internal termination helps absorb any reflections caused by imperfect termination at the receiver. When the internal termination is enabled, the output driver current is increased by 1.6x to maintain about the same output voltage swing.

## APPLICATIONS INFORMATION

### Phase-Shifting the Output Clock

In full-rate CMOS mode the data output bits normally change at the same time as the falling edge of CLKOUT<sup>+</sup>, so the rising edge of CLKOUT<sup>+</sup> can be used to latch the output data. In double-data rate CMOS and LVDS modes the data output bits normally change at the same time as the falling and rising edges of CLKOUT<sup>+</sup>. To allow adequate setup-and-hold time when latching the data, the CLKOUT<sup>+</sup> signal may need to be phase shifted relative to the data output bits. Most FPGAs have this feature; this is generally the best place to adjust the timing.

The LTC2259-16 can also phase shift the CLKOUT<sup>+</sup>/CLKOUT<sup>-</sup> signals by serially programming mode control register A2. The output clock can be shifted by 0°, 45°, 90° or 135°. To use the phase shifting feature the clock duty cycle stabilizer must be turned on. Another control register bit can invert the polarity of CLKOUT<sup>+</sup> and CLKOUT<sup>-</sup>, independently of the phase shift. The combination of these two features enables phase shifts of 45° up to 315° (Figure 14).

### DATA FORMAT

Table 1 shows the relationship between the analog input voltage and the digital data output bits. By default the output data format is offset binary. The 2's complement format can be selected by serially programming mode control register A4. Note that when the analog input is outside the normal operating range the two LSBs (D1, D0) can change and should be ignored.

**Table 1. Output Codes vs Input Voltage**

A <sub>IN</sub> <sup>+</sup> – A <sub>IN</sub> <sup>-</sup> (2V Range)	D15-D0 (OFFSET BINARY)	D15-D0 (2's COMPLEMENT)
>1.000000V	1111 1111 1111 11XX	0111 1111 1111 11XX
+0.999970V	1111 1111 1111 1111	0111 1111 1111 1111
+0.999939V	1111 1111 1111 1110	0111 1111 1111 1110
+0.999909V	1111 1111 1111 1101	0111 1111 1111 1101
+0.999978V	1111 1111 1111 1100	0111 1111 1111 1100
+0.000030V	1000 0000 0000 0001	0000 0000 0000 0001
+0.000000V	1000 0000 0000 0000	0000 0000 0000 0000
+0.000030V	0111 1111 1111 1111	1111 1111 1111 1111
+0.000061V	0111 1111 1111 1110	1111 1111 1111 1110
-0.999878V	0000 0000 0000 0011	1000 0000 0000 0011
-0.999909V	0000 0000 0000 0010	1000 0000 0000 0010
-0.999939V	0000 0000 0000 0001	1000 0000 0000 0001
-1.000000V	0000 0000 0000 0000	1000 0000 0000 0000
< -1.000000V	0000 0000 0000 00XX	1000 0000 0000 00XX

Note: X means data could be 1 or 0.

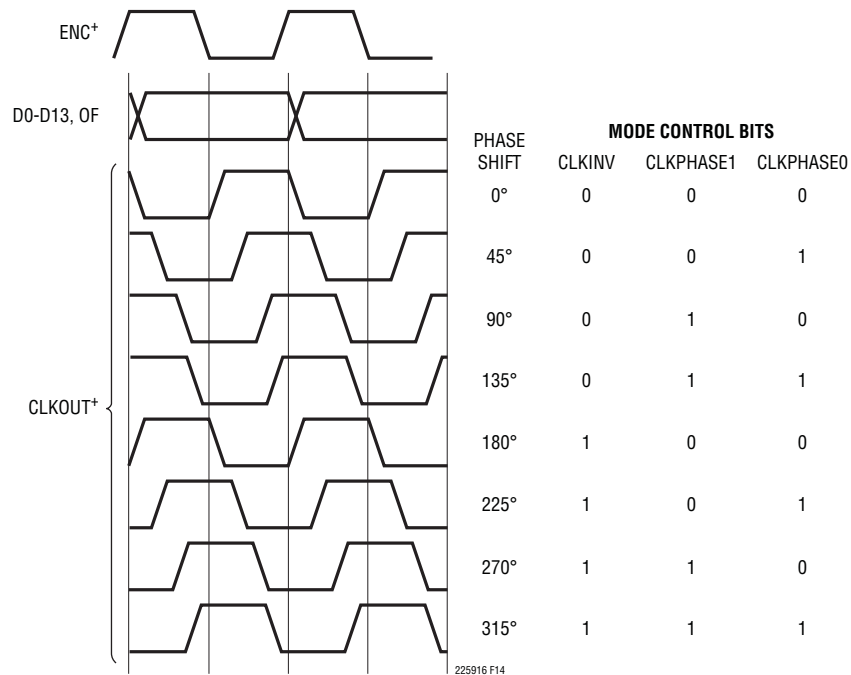

**Figure 14. Phase-Shifting CLKOUT**

## APPLICATIONS INFORMATION

### Digital Output Randomizer

Interference from the A/D digital outputs is sometimes unavoidable. Digital interference may be from capacitive or inductive coupling or coupling through the ground plane. Even a tiny coupling factor can cause unwanted tones in the ADC output spectrum. By randomizing the digital output before it is transmitted off chip, these unwanted tones can be randomized which reduces the unwanted tone amplitude.

The digital output is *randomized* by applying an exclusive-OR logic operation between D2 and all other data output bits. To decode, the reverse operation is applied—an exclusive-OR operation is applied between D2 and all other bits. The D2 and CLKOUT outputs are not affected. The output randomizer is enabled by serially programming mode control register A4.

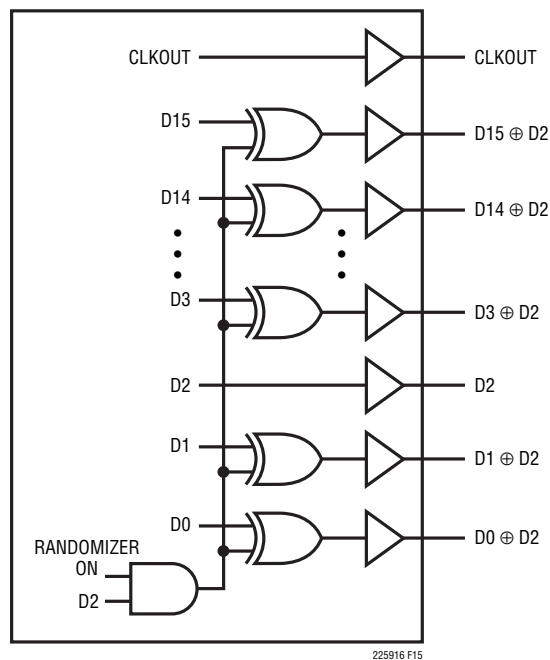

Figure 15. Functional Equivalent of Digital Output Randomizer

### Alternate Bit Polarity

Another feature that reduces digital feedback on the circuit board is the alternate bit polarity mode. When this mode is enabled, all of the odd bits (D1, D3, D5, D7, D9, D11, D13, D15) are inverted before the output buffers. The even bits (D0, D2, D4, D6, D8, D10, D12, D14) and CLKOUT are not affected. This can reduce digital currents in the circuit board ground plane and reduce digital noise, particularly for very small analog input signals.

When there is a very small signal at the input of the A/D that is centered around mid-scale, the digital outputs toggle between mostly 1s and mostly 0s. This simultaneous switching of most of the bits will cause large currents in the ground plane. By inverting every other bit, the alternate bit polarity mode makes half of the bits transition high while half of the bits transition low. To first order, this cancels current flow in the ground plane, reducing the digital noise.

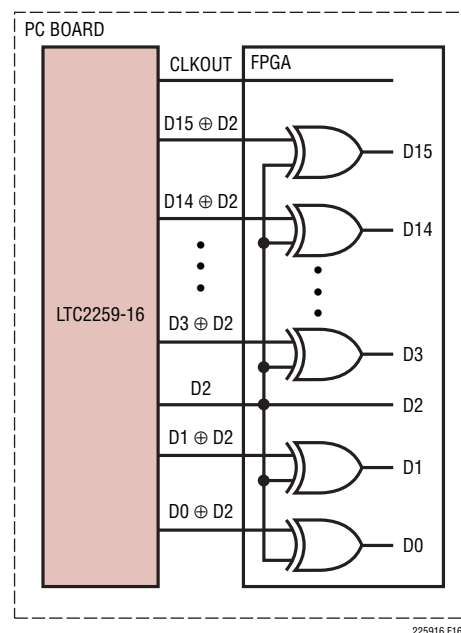

Figure 16. De-Randomizing a Randomized Digital Output Signal

## APPLICATIONS INFORMATION

The digital output is decoded at the receiver by inverting the odd bits (D1, D3, D5, D7, D9, D11, D13, D15). The alternate bit polarity mode is independent of the digital output randomizer—either, both or neither function can be on at the same time. When alternate bit polarity mode is on, the data format is offset binary and the 2's complement control bit has no effect. The alternate bit polarity mode is enabled by serially programming mode control register A4.

### Digital Output Test Patterns

To allow in-circuit testing of the digital interface to the A/D, there are several test modes that force most of the A/D data outputs (D15-D2) to known values. Note that the two LSBs, D1 and D0, are not controlled in the test pattern mode and can have unknown values.

All 1s: Outputs are 1111 1111 1111 11XX

All 0s: Outputs are 0000 0000 0000 00XX

Alternating: On alternating samples, the outputs change from 1111 1111 1111 11XX to 0000 0000 0000 00XX.

Checkerboard: On alternating samples, the outputs change from 1010 1010 1010 10XX to 0101 0101 0101 01XX.

The digital output test patterns are enabled by serially programming mode control register A4. When enabled, the test patterns override all other formatting modes: 2's complement, randomizer, alternate-bit-polarity.

### Output Disable

The digital outputs may be disabled by serially programming mode control register A3. All digital outputs including CLKOUT are disabled. The high impedance disabled state is intended for long periods of inactivity—it is too slow to multiplex a data bus between multiple converters at full speed.

### Sleep and Nap Modes

The A/D may be placed in sleep or nap modes to conserve power. In sleep mode the entire A/D converter is powered down, resulting in 0.5mW power consumption. Sleep mode is enabled by mode control register A1 (serial program-

ming mode), or by SDI (parallel programming mode). The amount of time required to recover from sleep mode depends on the size of the bypass capacitors on  $V_{REF}$ , REFH, and REFL. For the suggested values in Figure 8, the A/D will stabilize after 2ms.

In nap mode the A/D core is powered down while the internal reference circuits stay active, allowing faster wake-up than from sleep mode. Recovering from nap mode requires at least 100 clock cycles. If the application demands very accurate DC settling then an additional 50 $\mu$ s should be allowed so the on-chip references can settle from the slight temperature shift caused by the change in supply current as the A/D leaves nap mode. Nap mode is enabled by mode control register A1 in the serial programming mode.

## DEVICE PROGRAMMING MODES

The operating modes of the LTC2259-16 can be programmed by either a parallel interface or a simple serial interface. The serial interface has more flexibility and can program all available modes. The parallel interface is more limited and can only program some of the more commonly used modes.

### Parallel Programming Mode

To use the parallel programming mode,  $\overline{\text{PAR/SER}}$  should be tied to  $V_{DD}$ . The  $\overline{\text{CS}}$ , SCK and SDI pins are binary logic inputs that set certain operating modes. These pins can be tied to  $V_{DD}$  or ground, or driven by 1.8V, 2.5V or 3.3V CMOS logic. Table 2 shows the modes set by  $\overline{\text{CS}}$ , SCK and SDI.

**Table 2. Parallel Programming Mode Control Bits ( $\overline{\text{PAR/SER}} = V_{DD}$ )**

PIN	DESCRIPTION
$\overline{\text{CS}}$	Clock Duty Cycle Stabilizer Control Bit 0 = Clock Duty Cycle Stabilizer Off 1 = Clock Duty Cycle Stabilizer On
SCK	Digital Output Mode Control Bit 0 = Full-Rate CMOS Output Mode 1 = Double-Data Rate LVDS Output Mode (3.5mA LVDS Current, Internal Termination Off)
SDI	Power Down Control Bit 0 = Normal Operation 1 = Sleep Mode

## APPLICATIONS INFORMATION

### Serial Programming Mode

To use the serial programming mode,  $\overline{\text{PAR}}/\overline{\text{SER}}$  should be tied to ground. The  $\overline{\text{CS}}$ , SCK, SDI and SDO pins become a serial interface that program the A/D mode control registers. Data is written to a register with a 16-bit serial word. Data can also be read back from a register to verify its contents.

Serial data transfer starts when  $\overline{\text{CS}}$  is taken low. The data on the SDI pin is latched at the first 16 rising edges of SCK. Any SCK rising edges after the first 16 are ignored. The data transfer ends when  $\overline{\text{CS}}$  is taken high again.

The first bit of the 16-bit input word is the  $\overline{\text{R/W}}$  bit. The next seven bits are the address of the register (A6:A0). The final eight bits are the register data (D7:D0).

If the  $\overline{\text{R/W}}$  bit is low, the serial data (D7:D0) will be written to the register set by the address bits (A6:A0). If the  $\overline{\text{R/W}}$  bit is high, data in the register set by the address bits (A6:A0) will be read back on the SDO pin (see the timing

diagrams). During a read back command the register is not updated and data on SDI is ignored.

The SDO pin is an open-drain output that pulls to ground with a 200 $\Omega$  impedance. If register data is read back through SDO, an external 2k pull-up resistor is required. If serial data is only written and read back is not needed, then SDO can be left floating and no pull-up resistor is needed.

Table 3 shows a map of the mode control registers.

### Software Reset

If serial programming is used, the mode control registers should be programmed as soon as possible after the power supplies turn on and are stable. The first serial command must be a software reset which will reset all register data bits to logic 0. To perform a software reset, bit D7 in the reset register is written with a logic 1. After the reset is complete, bit D7 is automatically set back to zero.

**Table 3. Serial Programming Mode Register Map**

#### REGISTER A0: RESET REGISTER (ADDRESS 00h)

D7	D6	D5	D4	D3	D2	D1	D0
RESET	X	X	X	X	X	X	X

Bit 7      **RESET**      Software Reset Bit

0 = Not Used

1 = Software Reset. All mode control registers are reset to 00h. This bit is automatically set back to zero after the reset is complete.

Bits 6-0      Unused, Don't Care Bits.

#### REGISTER A1: POWER-DOWN REGISTER (ADDRESS 01h)

D7	D6	D5	D4	D3	D2	D1	D0
X	X	X	X	X	X	PWROFF1	PWROFF0

Bits 7-2      Unused, Don't Care Bits.

Bits 1-0      **PWROFF1:PWROFF0**      Power-Down Control Bits

00 = Normal Operation

01 = Nap Mode

10 = Not Used

11 = Sleep Mode

## APPLICATIONS INFORMATION

### REGISTER A2: TIMING REGISTER (ADDRESS 02h)

D7	D6	D5	D4	D3	D2	D1	D0
X	X	X	X	CLKINV	CLKPHASE1	CLKPHASE0	DCS

Bits 7-4

Unused, Don't Care Bits.

Bit 3

**CLKINV** Output Clock Invert Bit  
 0 = Normal CLKOUT Polarity (as shown in the timing diagrams)  
 1 = Inverted CLKOUT Polarity

Bits 2-1

**CLKPHASE1:CLKPHASE0** Output Clock Phase Delay Bits  
 00 = No CLKOUT Delay (as shown in the timing diagrams)  
 01 = CLKOUT+/CLKOUT- Delayed by 45° (Clock Period • 1/8)  
 10 = CLKOUT+/CLKOUT- Delayed by 90° (Clock Period • 1/4)  
 11 = CLKOUT+/CLKOUT- Delayed by 135° (Clock Period • 3/8)  
 Note: If the CLKOUT phase delay feature is used, the clock duty cycle stabilizer must also be turned on.

Bit 0

**DCS** Clock Duty Cycle Stabilizer Bit  
 0 = Clock Duty Cycle Stabilizer Off  
 1 = Clock Duty Cycle Stabilizer On

### REGISTER A3: OUTPUT MODE REGISTER (ADDRESS 03h)

D7	D6	D5	D4	D3	D2	D1	D0
X	ILVDS2	ILVDS1	ILVDS0	TERMON	OUTOFF	OUTMODE1	OUTMODE0

Bit 7

Unused, Don't Care Bit.

Bits 6-4

**ILVDS2:ILVDS0** LVDS Output Current Bits  
 000 = 3.5mA LVDS Output Driver Current  
 001 = 4.0mA LVDS Output Driver Current  
 010 = 4.5mA LVDS Output Driver Current  
 011 = Not Used  
 100 = 3.0mA LVDS Output Driver Current  
 101 = 2.5mA LVDS Output Driver Current  
 110 = 2.1mA LVDS Output Driver Current  
 111 = 1.75mA LVDS Output Driver Current

Bit 3

**TERMON** LVDS Internal Termination Bit  
 0 = Internal Termination Off  
 1 = Internal Termination On. LVDS output driver current is 1.6× the current set by ILVDS2:ILVDS0.

Bit 2

**OUTOFF** Output Disable Bit  
 0 = Digital Outputs are enabled.  
 1 = Digital Outputs are disabled and have high output impedance.

Bits 1-0

**OUTMODE1:OUTMODE0** Digital Output Mode Control Bits  
 00 = Full-Rate CMOS Output Mode  
 01 = Double-Data Rate LVDS Output Mode  
 10 = Double-Data Rate CMOS Output Mode  
 11 = Not Used



## APPLICATIONS INFORMATION

### REGISTER A4: DATA FORMAT REGISTER (ADDRESS 04h)

D7	D6	D5	D4	D3	D2	D1	D0
X	X	OUTTEST2	OUTTEST1	OUTTEST0	ABP	RAND	TWOSCOMP

Bit 7-6 Unused, Don't Care Bits.

Bits 5-3 **OUTTEST2:OUTTEST0** Digital Output Test Pattern Bits  
 000 = Digital Output Test Patterns Off  
 001 = Digital Outputs = 0000 0000 0000 00XX  
 011 = Digital Outputs = 1111 1111 1111 11XX  
 101 = Checkerboard Output Pattern. D15-D0 alternate between 0101 0101 0101 01XX and 1010 1010 1010 10XX.  
 111 = Alternating Output Pattern. D15-D0 alternate between 0000 0000 0000 00XX and 1111 1111 1111 11XX.  
 Note: Other bit combinations are not used. D1 and D0 are not controlled by the digital output test patterns.

Bit 2 **ABP** Alternate Bit Polarity Mode Control Bit  
 0 = Alternate Bit Polarity Mode Off  
 1 = Alternate Bit Polarity Mode On

Bit 1 **RAND** Data Output Randomizer Mode Control Bit  
 0 = Data Output Randomizer Mode Off  
 1 = Data Output Randomizer Mode On

Bit 0 **TWOSCOMP** Two's Complement Mode Control Bit  
 0 = Offset Binary Data Format  
 1 = Two's Complement Data Format  
 Note: ABP = 1 forces the output format to be offset binary.

### GROUNDING AND BYPASSING

The LTC2259-16 requires a printed circuit board with a clean unbroken ground plane. A multilayer board with an internal ground plane in the first layer beneath the ADC is recommended. Layout for the printed circuit board should ensure that digital and analog signal lines are separated as much as possible. In particular, care should be taken not to run any digital track alongside an analog signal track or underneath the ADC.

High quality ceramic bypass capacitors should be used at the  $V_{DD}$ ,  $OV_{DD}$ ,  $V_{CM}$ ,  $V_{REF}$ , REFH and REFL pins. Bypass capacitors must be located as close to the pins as possible. Of particular importance is the 0.1 $\mu$ F capacitor between REFH and REFL. This capacitor should be on the same side of the circuit board as the A/D, and as close to the device as possible (1.5mm or less). Size 0402 ceramic capacitors are recommended. The larger 2.2 $\mu$ F capacitor between REFH and REFL can be somewhat further away.

The  $V_{CM}$  capacitor should be located as close to the pin as possible. To make space for this the capacitor on  $V_{REF}$  can be further away or on the back of the PC board. The traces connecting the pins and bypass capacitors must be kept short and should be made as wide as possible.

The analog inputs, encode signals, and digital outputs should not be routed next to each other. Ground fill and grounded vias should be used as barriers to isolate these signals from each other.

### HEAT TRANSFER

Most of the heat generated by the LTC2259-16 is transferred from the die through the bottom-side exposed pad and package leads onto the printed circuit board. For good electrical and thermal performance, the exposed pad must be soldered to a large grounded pad on the PC board. This pad should be connected to the internal ground planes by an array of vias.

## TYPICAL APPLICATIONS

LTC2259-16 Schematic

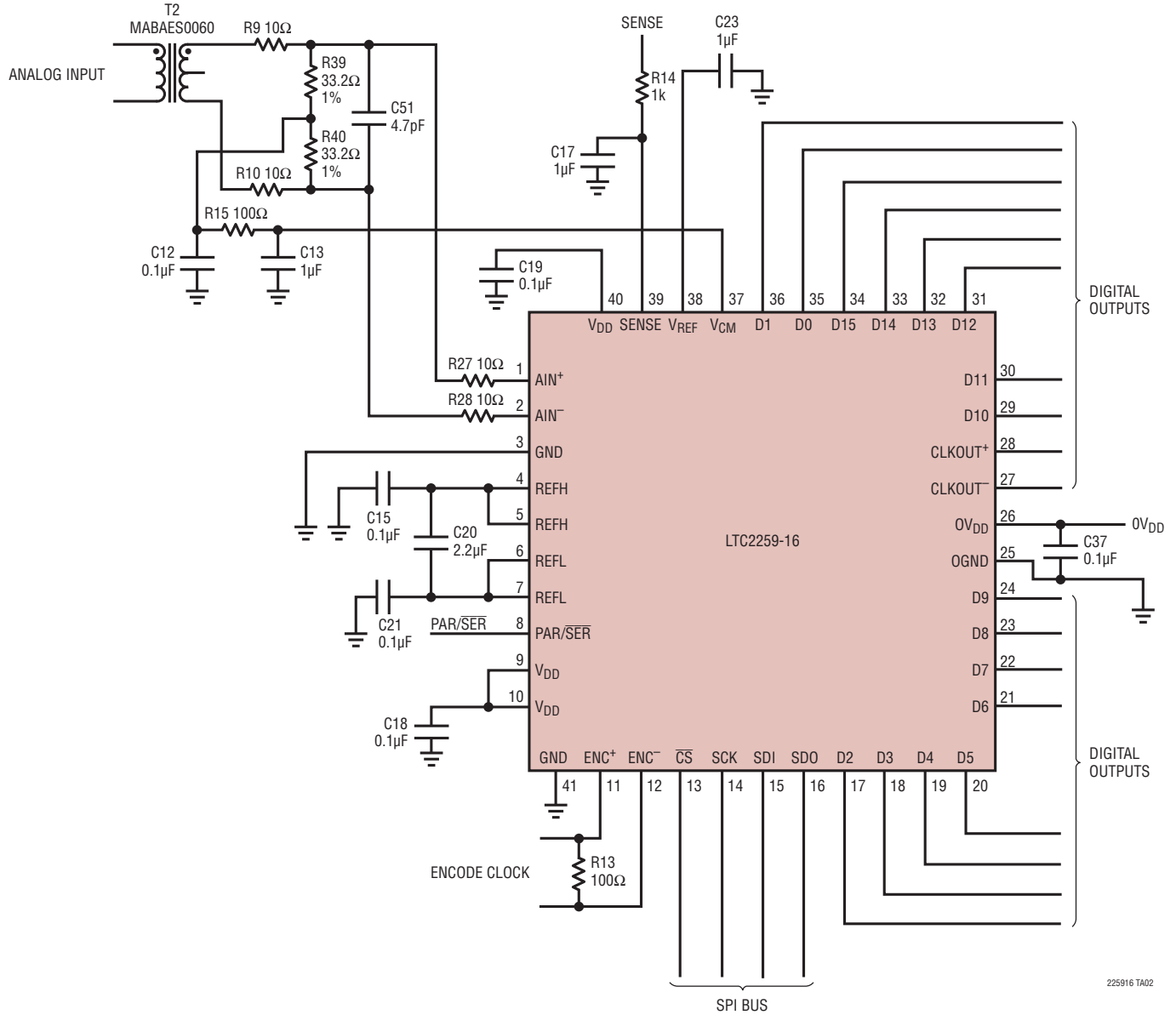

225916 TA02



# TYPICAL APPLICATIONS

Silkscreen Top

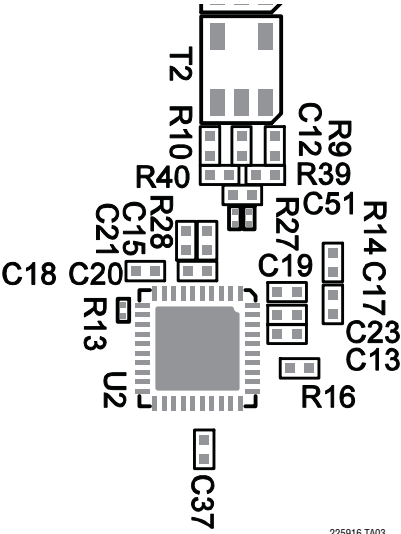

225916 TA03

Top Side

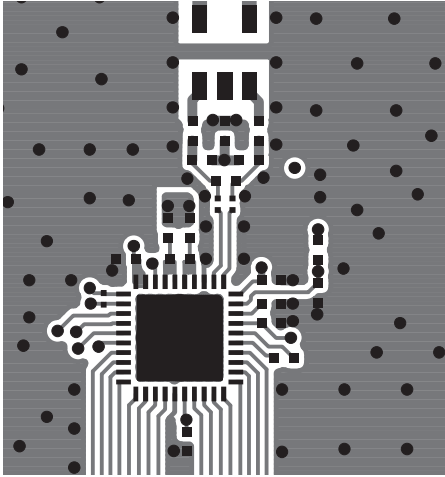

225916 TA04

Inner Layer 2 GND

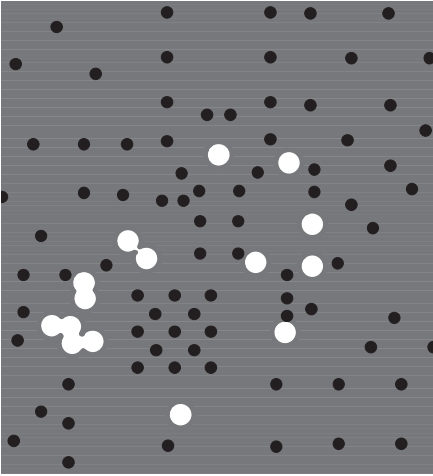

225916 TA04

Inner Layer 3

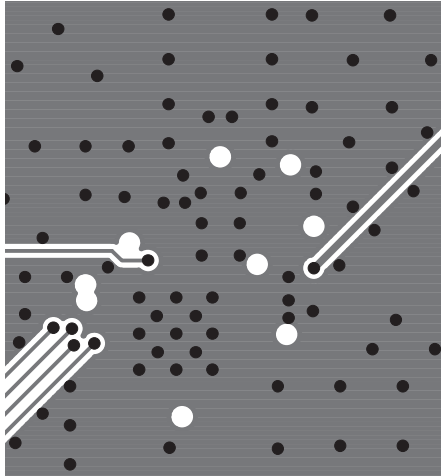

225916 TA06

TYPICAL APPLICATIONS

Inner Layer 4

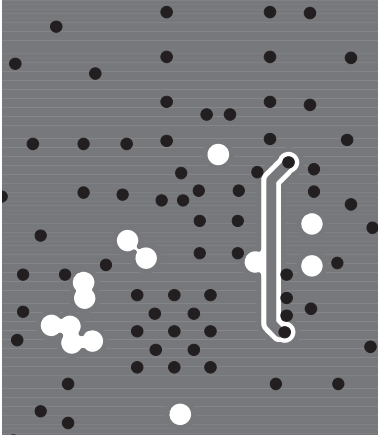

225916 TA07

Inner Layer 5 Power

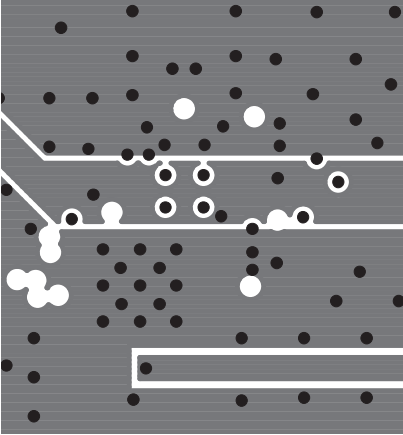

225916 TA08

Bottom Side

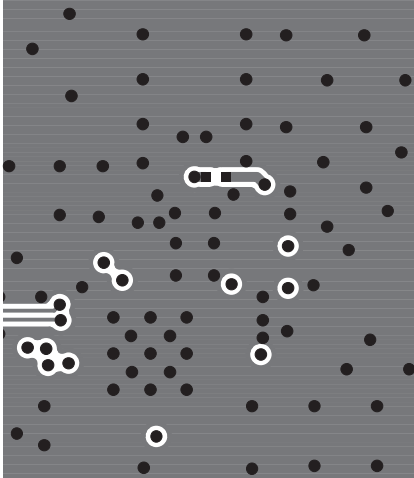

225916 TA09

# PACKAGE DESCRIPTION

**UJ Package**  
**40-Lead Plastic QFN (6mm × 6mm)**  
 (Reference LTC DWG # 05-08-1728 Rev 0)

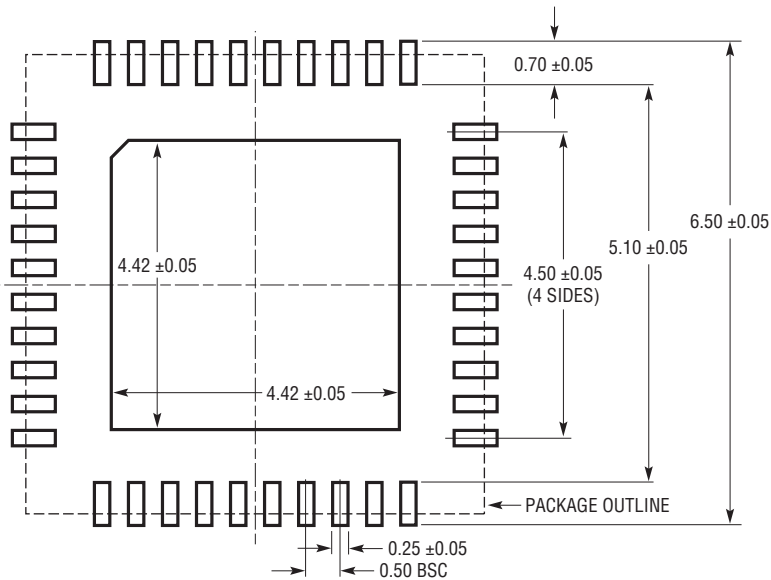

RECOMMENDED SOLDER PAD PITCH AND DIMENSIONS  
 APPLY SOLDER MASK TO AREAS THAT ARE NOT SOLDERED

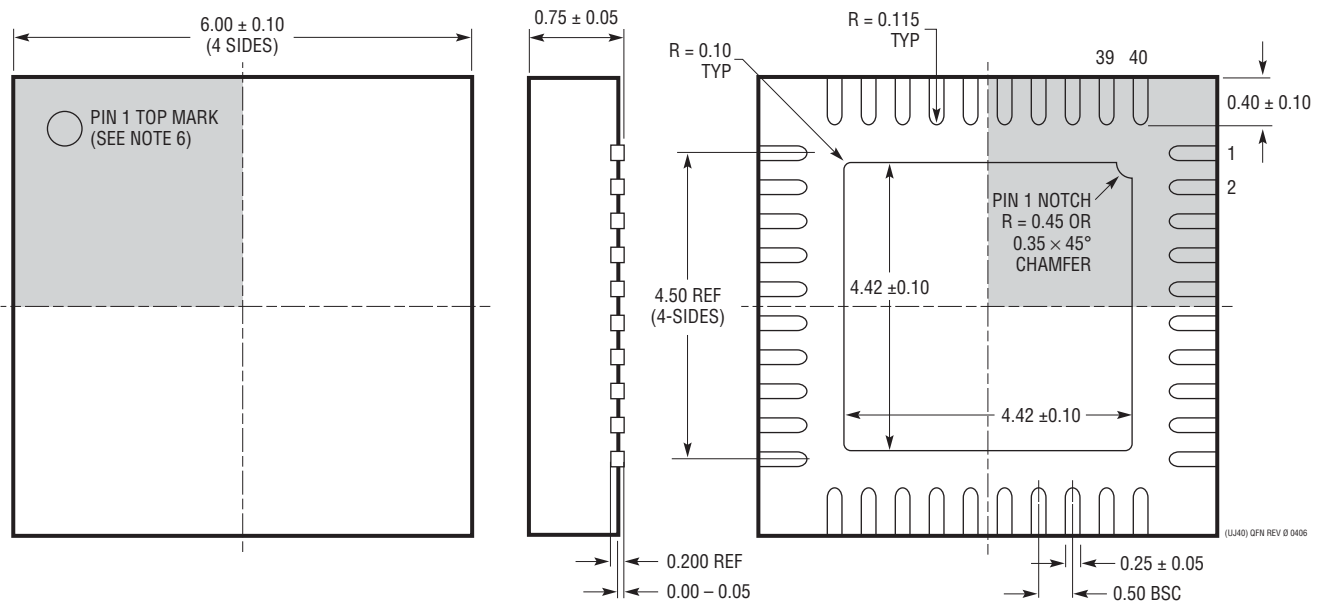

- NOTE:
1. DRAWING IS A JEDEC PACKAGE OUTLINE VARIATION OF (WJJD-2)
  2. DRAWING NOT TO SCALE
  3. ALL DIMENSIONS ARE IN MILLIMETERS
  4. DIMENSIONS OF EXPOSED PAD ON BOTTOM OF PACKAGE DO NOT INCLUDE MOLD FLASH. MOLD FLASH, IF PRESENT, SHALL NOT EXCEED 0.20mm ON ANY SIDE, IF PRESENT
  5. EXPOSED PAD SHALL BE SOLDER PLATED
  6. SHADED AREA IS ONLY A REFERENCE FOR PIN 1 LOCATION ON THE TOP AND BOTTOM OF PACKAGE

BOTTOM VIEW—EXPOSED PAD

## TYPICAL APPLICATION

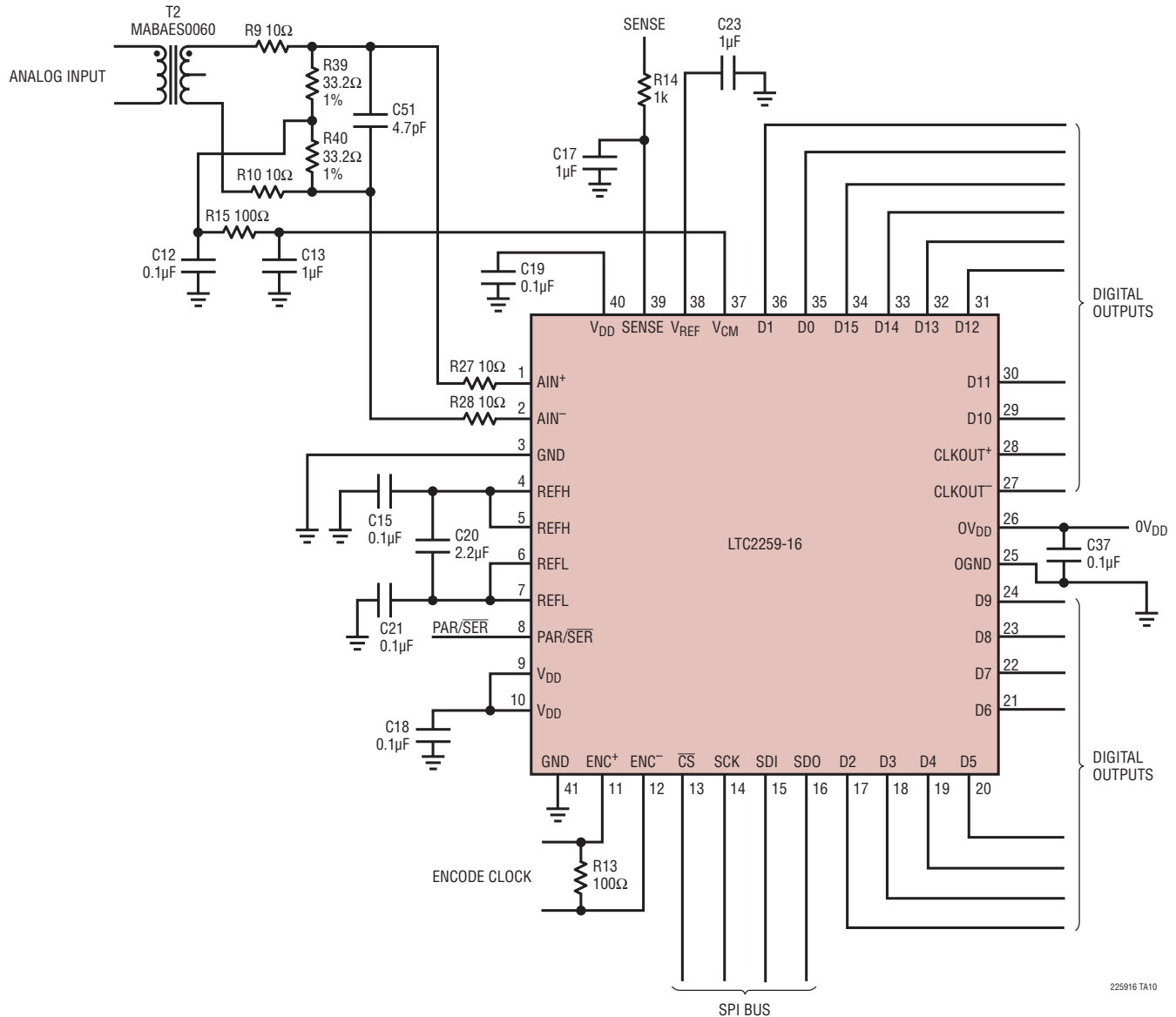

225916 TA10

## RELATED PARTS

PART NUMBER	DESCRIPTION	COMMENTS
LTC1993-2	High Speed Differential Op-Amp/ADC Driver	800MHz 70dBc Distortion at 70MHz, 6dB Gain
LTC1994	Low Noise, Low Distortion Fully Differential Input/Output Amplifier/Driver	Low Distortion: -94dBc at 1MHz
LTC6406	3GHz, Low Noise, Rail-to-Rail Input Differential Amplifier/Driver	Low Noise: 1.6nV/√Hz RTI
LTC2259-14/ LTC2260-14/ LTC2261-14	14-Bit, 80Msps/105Msps/125Msps Ultralow Power 1.8V ADCs	89mW/106mW/127mW, 73.4dB SNR, 85dB SFDR, DDR LVDS/DDR CMOS/CMOS Outputs, 6mm × 6mm QFN Package
LTC2259-12/ LTC2260-12/ LTC2261-12	12-Bit, 80Msps/105Msps/125Msps Ultralow Power 1.8V ADCs	87mW/103mW/124mW, 70.8dB SNR, 85dB SFDR, DDR LVDS/DDR CMOS/CMOS Outputs, 6mm × 6mm QFN Package

225916f