

12-Bit, 65/40/2 5MSPS Ultralow Power 1.8V ADCs

FEATURES

- 71.1dB SNR
- 88dB SFDR
- Low Power: 79mW/47mW/34mW
- Single 1.8V Supply
- CMOS, DDR CMOS or DDR LVDS Outputs
- Selectable Input Ranges: 1V_{P-P} to 2V_{P-P}
- 800MHz Full-Power Bandwidth S/H
- Optional Data Output Randomizer
- Optional Clock Duty Cycle Stabilizer
- Shutdown and Nap Modes
- Serial SPI Port for Configuration
- Pin Compatible 14-Bit and 12-Bit Versions
- 40-Pin (6mm × 6mm) QFN Package

APPLICATIONS

- Communications
- Cellular Base Stations
- Software Defined Radios
- Portable Medical Imaging
- Multi-Channel Data Acquisition
- Nondestructive Testing

DESCRIPTION

The LTC[®]2258-12/LTC2257-12/LTC2256-12 are sampling 12-bit A/D converters designed for digitizing high frequency, wide dynamic range signals. They are perfect for demanding communications applications with AC performance that includes 71.1dB SNR and 85dB spurious free dynamic range (SFDR). Ultralow jitter of 0.17ps_{RMS} allows undersampling of IF frequencies with excellent noise performance.

DC specs include ±0.3LSB INL (typical), ±0.1LSB DNL (typical) and no missing codes over temperature. The transition noise is a low 0.3LSB_{RMS}.

The digital outputs can be either full rate CMOS, double data rate CMOS, or double data rate LVDS. A separate output power supply allows the CMOS output swing to range from 1.2V to 1.8V.

The ENC⁺ and ENC⁻ inputs may be driven differentially or single-ended with a sine wave, PECL, LVDS, TTL or CMOS inputs. An optional clock duty cycle stabilizer allows high performance at full speed for a wide range of clock duty cycles.

LT, LTC and LTM are registered trademarks of Linear Technology Corporation. All other trademarks are the property of their respective owners.

TYPICAL APPLICATION

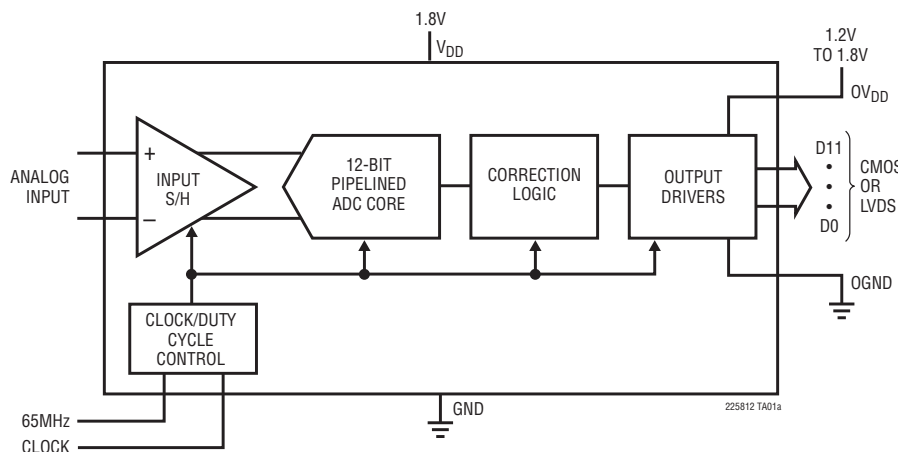

2-Tone FFT, $f_{IN} = 68\text{MHz}$ and 69MHz

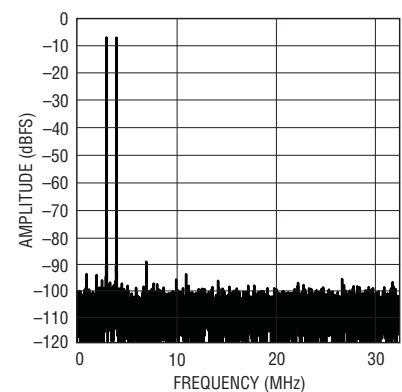

LTC2258-12

LTC2257-12/LTC2256-12

ABSOLUTE MAXIMUM RATINGS (Notes 1, 2)

Supply Voltages (V_{DD} , OV_{DD}).....	-0.3V to 2V	Digital Output Voltage	-0.3V to ($OV_{DD} + 0.3V$)
Analog Input Voltage (A_{IN}^+ , A_{IN}^- , PAR/SER, SENSE) (Note 3).....	-0.3V to ($V_{DD} + 0.2V$)	Operating Temperature Range:	
Digital Input Voltage (ENC^+ , ENC^- , \overline{CS} , SDI, SCK) (Note 4).....	-0.3V to 3.9V	LTC2258C, LTC2257C, LTC2256C.....	0°C to 70°C
SDO (Note 4)	-0.3V to 3.9V	LTC2258I, LTC2257I, LTC2256I.....	-40°C to 85°C
		Storage Temperature Range.....	-65°C to 150°C

PIN CONFIGURATIONS

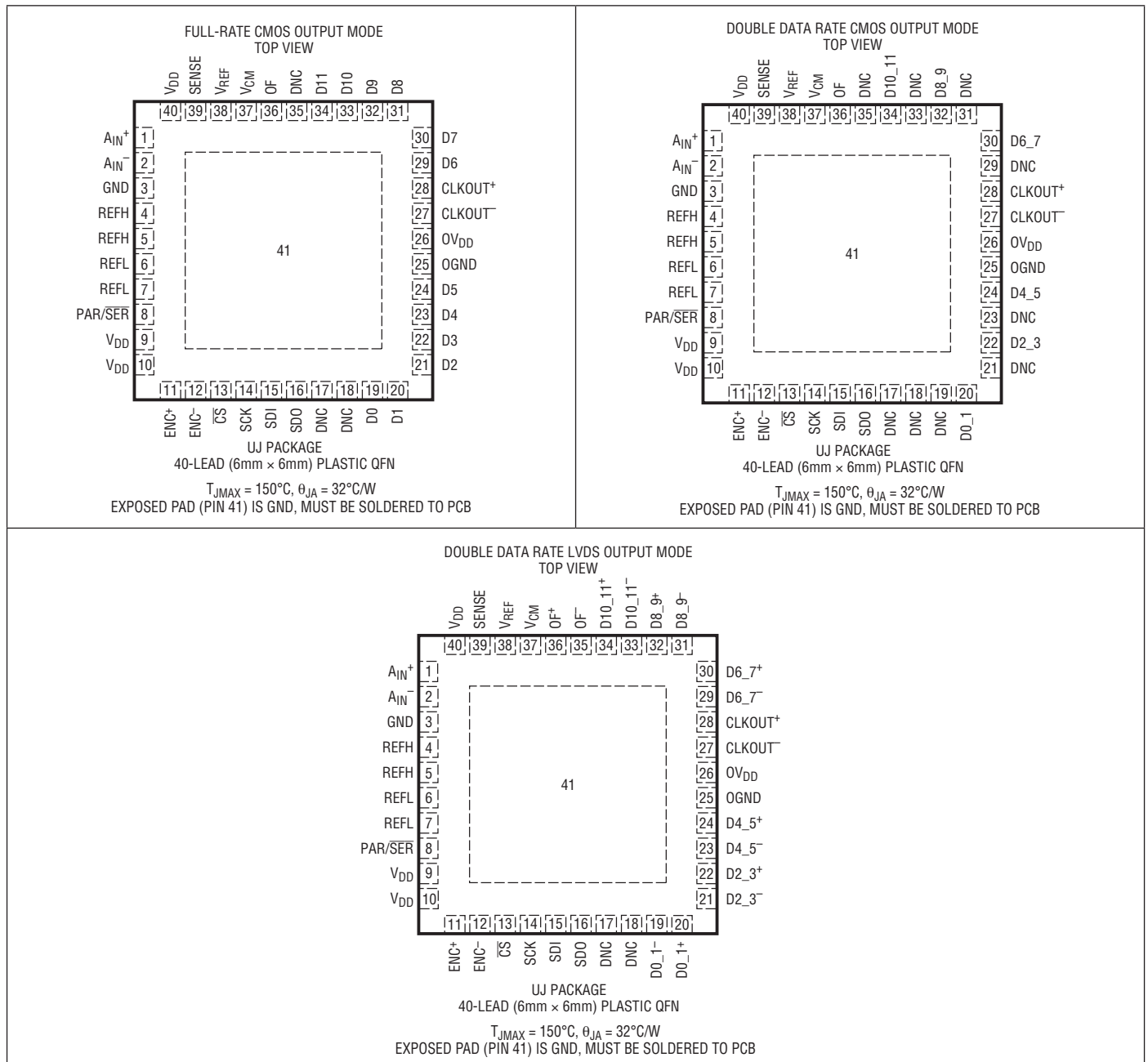

ORDER INFORMATION

LEAD FREE FINISH	TAPE AND REEL	PART MARKING*	PACKAGE DESCRIPTION	TEMPERATURE RANGE
LTC2258CUJ-12#PBF	LTC2258CUJ-12#TRPBF	LTC2258UJ-12	40-Lead (6mm × 6mm) Plastic QFN	0°C to 70°C
LTC2258IUJ-12#PBF	LTC2258IUJ-12#TRPBF	LTC2258UJ-12	40-Lead (6mm × 6mm) Plastic QFN	-40°C to 85°C
LTC2257CUJ-12#PBF	LTC2257CUJ-12#TRPBF	LTC2257UJ-12	40-Lead (6mm × 6mm) Plastic QFN	0°C to 70°C
LTC2257IUJ-12#PBF	LTC2257IUJ-12#TRPBF	LTC2257UJ-12	40-Lead (6mm × 6mm) Plastic QFN	-40°C to 85°C
LTC2256CUJ-12#PBF	LTC2256CUJ-12#TRPBF	LTC2256UJ-12	40-Lead (6mm × 6mm) Plastic QFN	0°C to 70°C
LTC2256IUJ-12#PBF	LTC2256IUJ-12#TRPBF	LTC2256UJ-12	40-Lead (6mm × 6mm) Plastic QFN	-40°C to 85°C

Consult LTC Marketing for parts specified with wider operating temperature ranges. *The temperature grade is identified by a label on the shipping container. Consult LTC Marketing for information on non-standard lead based finish parts.

For more information on lead free part marking, go to: <http://www.linear.com/leadfree/>

For more information on tape and reel specifications, go to: <http://www.linear.com/tapeandreeel/>

CONVERTER CHARACTERISTICS

The ● denotes the specifications which apply over the full operating temperature range, otherwise specifications are at $T_A = 25^\circ\text{C}$. (Note 5)

PARAMETER	CONDITIONS	LTC2261-12			LTC2260-12			LTC2259-12			UNITS	
		MIN	TYP	MAX	MIN	TYP	MAX	MIN	TYP	MAX		
Resolution (No Missing Codes)		●	12		12		12		12		Bits	
Integral Linearity Error	Differential Analog Input (Note 6)	●	-1	±0.3	1	-1	±0.3	1	-1	±0.3	1	LSB
Differential Linearity Error	Differential Analog Input	●	-0.4	±0.1	0.4	-0.4	±0.1	0.4	-0.4	±0.1	0.4	LSB
Offset Error	(Note 7)	●	-9	±1.5	9	-9	±1.5	9	-9	±1.5	9	mV
Gain Error	Internal Reference			±1.5			±1.5			±1.5		%FS
	External Reference	●	-1.5	±0.4	1.5	-1.5	±0.4	1.5	-1.5	±0.4	1.5	%FS
Offset Drift				±20			±20			±20		μV/°C
Full-Scale Drift	Internal Reference			±30			±30			±30		ppm/°C
	External Reference			±10			±10			±10		ppm/°C
Transition Noise	External Reference			0.3			0.3			0.3		LSB _{RMS}

ANALOG INPUT The ● denotes the specifications which apply over the full operating temperature range, otherwise specifications are at $T_A = 25^\circ\text{C}$. (Note 5)

SYMBOL	PARAMETER	CONDITIONS		MIN	TYP	MAX	UNITS
V_{IN}	Analog Input Range ($A_{IN}^+ - A_{IN}^-$)	$1.7V < V_{DD} < 1.9V$	●		1 to 2		V_{P-P}
$V_{IN(CM)}$	Analog Input Common Mode ($A_{IN}^+ + A_{IN}^-$)/2	Differential Analog Input (Note 8)	●	$V_{CM} - 100mV$	V_{CM}	$V_{CM} + 100mV$	V
V_{SENSE}	External Voltage Reference Applied to SENSE	External Reference Mode	●	0.625	1.250	1.300	V
I_{INCM}	Analog Input Common Mode Current	Per Pin, 125Msps Per Pin, 105Msps Per Pin, 80Msps			155 130 100		μA μA μA
I_{IN1}	Analog Input Leakage Current	$0 < A_{IN}^+, A_{IN}^- < V_{DD}$, No Encode	●	-1		1	μA
I_{IN2}	PAR/SER Input Leakage Current	$0 < PAR/SER < V_{DD}$	●	-3		3	μA
I_{IN3}	SENSE Input Leakage Current	$0.625V < SENSE < 1.3V$	●	-6		6	μA
t_{AP}	Sample-and-Hold Acquisition Delay Time				0		ns
t_{JITTER}	Sample-and-Hold Acquisition Delay Jitter				0.17		psRMS
CMRR	Analog Input Common Mode Rejection Ratio				80		dB
BW-3B	Full-Power Bandwidth	Figure 6 Test Circuit			800		MHz

DYNAMIC ACCURACY The ● denotes the specifications which apply over the full operating temperature range, otherwise specifications are at $T_A = 25^\circ\text{C}$. $A_{IN} = -1\text{dBFS}$. (Note 5)

SYMBOL	PARAMETER	CONDITIONS	LTC2258-12			LTC2257-12			LTC2256-12			UNITS
			MIN	TYP	MAX	MIN	TYP	MAX	MIN	TYP	MAX	
SNR	Signal-to-Noise Ratio	5MHz Input		71.1		70.8		70.5			dB	
		70MHz Input	●	69.4	71	69.4	70.6	69.1	70		dB	
		140MHz Input			70.8		70.4		69.7		dB	
SFDR	Spurious Free Dynamic Range 2nd or 3rd Harmonic	5MHz Input		91.7		91.7		91.9			dB	
		70MHz Input	●	76	91.5	76	91.3	79	95.4		dB	
		140MHz Input			81.1		85.7		89.8		dB	
S/(N+D)	Signal-to-Noise Plus Distortion Ratio	5MHz Input		71		70.7		70.4			dB	
		70MHz Input	●	68.6	70.9	68.6	70.6	68.8	69.8		dB	
		140MHz Input			70.3		70.2		69.5		dB	

INTERNAL REFERENCE CHARACTERISTICS The ● denotes the specifications which apply over the full operating temperature range, otherwise specifications are at $T_A = 25^\circ\text{C}$. (Note 5)

PARAMETER	CONDITIONS	MIN	TYP	MAX	UNITS
V_{CM} Output Voltage	$I_{OUT} = 0$	$0.5 \cdot V_{DD} - 25mV$	$0.5 \cdot V_{DD}$	$0.5 \cdot V_{DD} + 25mV$	V
V_{CM} Output Temperature Drift			± 25		ppm/ $^\circ\text{C}$
V_{CM} Output Resistance	$-600\mu A < I_{OUT} < 1mA$		4		Ω
V_{REF} Output Voltage	$I_{OUT} = 0$	1.225	1.250	1.275	V
V_{REF} Output Temperature Drift			± 25		ppm/ $^\circ\text{C}$
V_{REF} Output Resistance	$-400\mu A < I_{OUT} < 1mA$		7		Ω
V_{REF} Line Regulation	$1.7V < V_{DD} < 1.9V$		0.6		mV/V

DIGITAL INPUTS AND OUTPUTS The ● denotes the specifications which apply over the full operating temperature range, otherwise specifications are at $T_A = 25^\circ\text{C}$. (Note 5)

SYMBOL	PARAMETER	CONDITIONS		MIN	TYP	MAX	UNITS
ENCODE INPUTS (ENC⁺, ENC⁻)							
Differential Encode Mode (ENC⁻ Not Tied to GND)							
V _{ID}	Differential Input Voltage	(Note 8)	●	0.2			V
V _{ICM}	Common Mode Input Voltage	Internally Set Externally Set (Note 8)	●	1.1	1.2	1.6	V V
V _{IN}	Input Voltage Range	ENC ⁺ , ENC ⁻ to GND	●	0.2		3.6	V
R _{IN}	Input Resistance	(See Figure 10)			10		kΩ
C _{IN}	Input Capacitance	(Note 8)			3.5		pF
Single-Ended Encode Mode (ENC⁻ Tied to GND)							
V _{IH}	High Level Input Voltage	V _{DD} = 1.8V	●	1.2			V
V _{IL}	Low Level Input Voltage	V _{DD} = 1.8V	●			0.6	V
V _{IN}	Input Voltage Range	ENC ⁺ to GND	●	0		3.6	V
R _{IN}	Input Resistance	(See Figure 11)			30		kΩ
C _{IN}	Input Capacitance	(Note 8)			3.5		pF
DIGITAL INPUTS (CS, SDI, SCK)							
V _{IH}	High Level Input Voltage	V _{DD} = 1.8V	●	1.3			V
V _{IL}	Low Level Input Voltage	V _{DD} = 1.8V	●			0.6	V
I _{IN}	Input Current	V _{IN} = 0V to 3.6V	●	-10		10	μA
C _{IN}	Input Capacitance	(Note 8)			3		pF
SDO OUTPUT (Open-Drain Output. Requires 2k Pull-Up Resistor if SDO is Used)							
R _{OL}	Logic Low Output Resistance to GND	V _{DD} = 1.8V, SDO = 0V			200		Ω
I _{OH}	Logic High Output Leakage Current	SDO = 0V to 3.6V	●	-10		10	μA
C _{OUT}	Output Capacitance	(Note 8)			4		pF
DIGITAL DATA OUTPUTS (CMOS MODES: FULL DATA RATE AND DOUBLE DATA RATE)							
OV_{DD} = 1.8V							
V _{OH}	High Level Output Voltage	I _O = -500μA	●	1.750	1.790		V
V _{OL}	Low Level Output Voltage	I _O = 500μA	●		0.010	0.050	V
OV_{DD} = 1.5V							
V _{OH}	High Level Output Voltage	I _O = -500μA			1.488		V
V _{OL}	Low Level Output Voltage	I _O = 500μA			0.010		V
OV_{DD} = 1.2V							
V _{OH}	High Level Output Voltage	I _O = -500μA			1.185		V
V _{OL}	Low Level Output Voltage	I _O = 500μA			0.010		V
DIGITAL DATA OUTPUTS (LVDS MODE)							
V _{OD}	Differential Output Voltage	100Ω Differential Load, 3.5mA Mode 100Ω Differential Load, 1.75mA Mode	●	247	350 175	454	mV mV
V _{OS}	Common Mode Output Voltage	100Ω Differential Load, 3.5mA Mode 100Ω Differential Load, 1.75mA Mode	●	1.125	1.250 1.250	1.375	V V
R _{TERM}	On-Chip Termination Resistance	Termination Enabled, OV _{DD} = 1.8V			100		Ω

LTC2258-12

LTC2257-12/LTC2256-12

POWER REQUIREMENTS

The ● denotes the specifications which apply over the full operating temperature range, otherwise specifications are at $T_A = 25^\circ\text{C}$. (Note 9)

SYMBOL	PARAMETER	CONDITIONS	LTC2258-12			LTC2257-12			LTC2256-12			UNITS	
			MIN	TYP	MAX	MIN	TYP	MAX	MIN	TYP	MAX		
CMOS Output Modes: Full Data Rate and Double Data Rate													
V_{DD}	Analog Supply Voltage	(Note 10)	●	1.7	1.8	1.9	1.7	1.8	1.9	1.7	1.8	1.9	V
OV_{DD}	Output Supply Voltage	(Note 10)	●	1.1		1.9	1.1		1.9	1.1		1.9	V
I_{VDD}	Analog Supply Current	DC Input Sine Wave Input	●		43.6 44.2	81.1		26.3 27.2	67.4		18.9 19.1	56.6	mA mA
I_{OVDD}	Digital Supply Current	Sine Wave Input, $OV_{DD}=1.2\text{V}$			2.3			1.5			0.9		mA
P_{DISS}	Power Dissipation	DC Input Sine Wave Input, $OV_{DD}=1.2\text{V}$	●		78.5 82.3	146		47.3 50.8	122		34 35.5	102	mW mW

LVDS Output Mode

V_{DD}	Analog Supply Voltage	(Note 10)	●	1.7	1.8	1.9	1.7	1.8	1.9	1.7	1.8	1.9	V
OV_{DD}	Output Supply Voltage	(Note 10)	●	1.7		1.9	1.7		1.9	1.7		1.9	V
I_{VDD}	Analog Supply Current	Sine Wave Input	●		48.1	86.9		30.6	73.1		22.7	62.2	mA
I_{OVDD}	Digital Supply Current ($OV_{DD} = 1.8\text{V}$)	Sine Input, 1.75mA Mode Sine Input, 3.5mA Mode	● ●		21.7 36.2	22.2 43.3		21.4 35.5	22.2 43.3		21.6 35.9	22.2 43.3	mA mA
P_{DISS}	Power Dissipation	Sine Input, 1.75mA Mode Sine Input, 3.5mA Mode	● ●		125.6 151.7	196 235		93.6 119	172 210		79.7 105.5	152 190	mW mW

All Output Modes

P_{SLEEP}	Sleep Mode Power				0.5			0.5			0.5		mW
P_{NAP}	Nap Mode Power				9			9			9		mW
$P_{DIFFCLK}$	Power Increase with Differential Encode Mode Enabled (No increase for Nap or Sleep Modes)				10			10			10		mW

TIMING CHARACTERISTICS

The ● denotes the specifications which apply over the full operating temperature range, otherwise specifications are at $T_A = 25^\circ\text{C}$. (Note 5)

SYMBOL	PARAMETER	CONDITIONS	LTC2258-12			LTC2257-12			LTC2256-12			UNITS	
			MIN	TYP	MAX	MIN	TYP	MAX	MIN	TYP	MAX		
f_S	Sampling Frequency	(Note 10)	●	1		65	1		40	1		25	MHz
t_L	ENC Low Time (Note 8)	Duty Cycle Stabilizer Off	●	7.3	7.69	500	11.8	12.5	500	19	20	500	ns
		Duty Cycle Stabilizer On	●	2.0	7.69	500	2.00	12.5	500	2.00	20	500	ns
t_H	ENC High Time (Note 8)	Duty Cycle Stabilizer Off	●	7.3	7.69	500	11.8	12.5	500	19	20	500	ns
		Duty Cycle Stabilizer On	●	2.0	7.69	500	2.00	12.5	500	2.00	20	500	ns
t_{AP}	Sample-and-Hold Acquisition Delay Time				0			0			0		ns

SYMBOL	PARAMETER	CONDITIONS	MIN	TYP	MAX	UNITS	
Digital Data Outputs (CMOS Modes: Full Data Rate and Double Data Rate)							
t_D	ENC to Data Delay	$C_L = 5\text{pF}$ (Note 8)	●	1.1	1.7	3.1	ns
t_C	ENC to CLKOUT Delay	$C_L = 5\text{pF}$ (Note 8)	●	1	1.4	2.6	ns
t_{SKEW}	DATA to CLKOUT Skew	$t_D - t_C$ (Note 8)	●	0	0.3	0.6	ns
	Pipeline Latency	Full Data Rate Mode Double Data Rate Mode			5.0 5.5	Cycles Cycles	

TIMING CHARACTERISTICS

The ● denotes the specifications which apply over the full operating temperature range, otherwise specifications are at $T_A = 25^\circ\text{C}$. (Note 5)

SYMBOL	PARAMETER	CONDITIONS	MIN	TYP	MAX	UNITS
Digital Data Outputs (LVDS Mode)						
t_D	ENC to Data Delay	$C_L = 5\text{pF}$ (Note 8)	● 1.1	1.8	3.2	ns
t_C	ENC to CLKOUT Delay	$C_L = 5\text{pF}$ (Note 8)	● 1	1.5	2.7	ns
t_{SKEW}	DATA to CLKOUT Skew	$t_D - t_C$ (Note 8)	● 0	0.3	0.6	ns
	Pipeline Latency			5.5		Cycles
SPI Port Timing (Note 8)						
t_{SCK}	SCK Period	Write Mode Readback Mode, $C_{\text{SDO}} = 20\text{pF}$, $R_{\text{PULLUP}} = 2\text{k}$	● 40 ● 250			ns ns
t_S	$\overline{\text{CS}}$ to SCK Setup Time		● 5			ns
t_H	SCK to $\overline{\text{CS}}$ Setup Time		● 5			ns
t_{DS}	SDI Setup Time		● 5			ns
t_{DH}	SDI Hold Time		● 5			ns
t_{DO}	SCK Falling to SDO Valid	Readback Mode, $C_{\text{SDO}} = 20\text{pF}$, $R_{\text{PULLUP}} = 2\text{k}$	●		125	ns

Note 1: Stresses beyond those listed under Absolute Maximum Ratings may cause permanent damage to the device. Exposure to any Absolute Maximum Rating condition for extended periods may affect device reliability and lifetime.

Note 2: All voltage values are with respect to GND with GND and OGND shorted (unless otherwise noted).

Note 3: When these pin voltages are taken below GND or above V_{DD} , they will be clamped by internal diodes. This product can handle input currents of greater than 100mA below GND or above V_{DD} without latchup.

Note 4: When these pin voltages are taken below GND they will be clamped by internal diodes. When these pin voltages are taken above V_{DD} they will not be clamped by internal diodes. This product can handle input currents of greater than 100mA below GND without latchup.

Note 5: $V_{\text{DD}} = \text{OV}_{\text{DD}} = 1.8\text{V}$, $f_{\text{SAMPLE}} = 125\text{MHz}$ (LTC2261), 105MHz (LTC2260), or 80MHz (LTC2259), LVDS outputs with internal

termination disabled, differential $\text{ENC}^+/\text{ENC}^- = 2V_{\text{P-P}}$ sine wave, input range = $2V_{\text{P-P}}$ with differential drive, unless otherwise noted.

Note 6: Integral nonlinearity is defined as the deviation of a code from a best fit straight line to the transfer curve. The deviation is measured from the center of the quantization band.

Note 7: Offset error is the offset voltage measured from -0.5 LSB when the output code flickers between 0000 0000 0000 and 1111 1111 1111 in 2's complement output mode.

Note 8: Guaranteed by design, not subject to test.

Note 9: $V_{\text{DD}} = 1.8\text{V}$, $f_{\text{SAMPLE}} = 125\text{MHz}$ (LTC2261), 105MHz (LTC2260), or 80MHz (LTC2259), $\text{ENC}^+ =$ single-ended 1.8V square wave, $\text{ENC}^- = 0\text{V}$, input range = $2V_{\text{P-P}}$ with differential drive, 5pF load on each digital output unless otherwise noted.

Note 10: Recommended operating conditions.

TIMING DIAGRAMS

Full-Rate CMOS Output Mode Timing
All Outputs Are Single-Ended and Have CMOS Levels

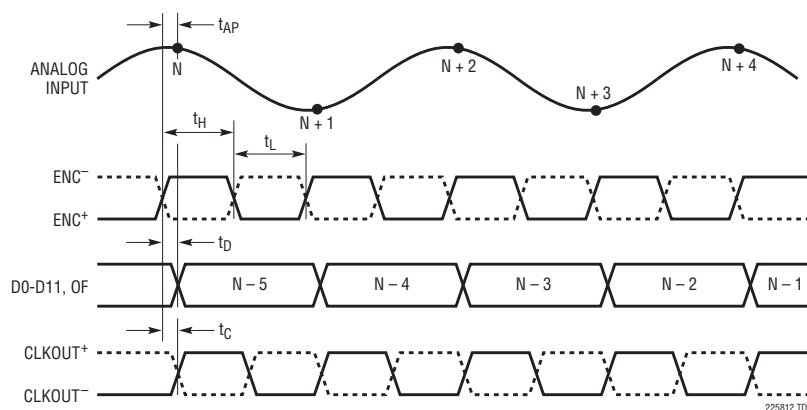

TIMING DIAGRAMS

Double Data Rate CMOS Output Mode Timing
All Outputs Are Single-Ended and Have CMOS Levels

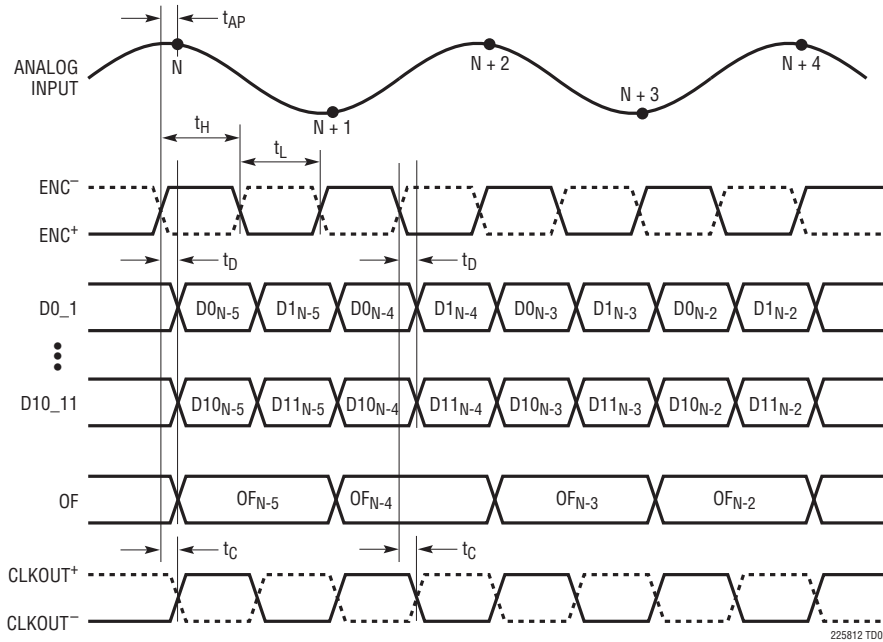

Double Data Rate LVDS Output Mode Timing
All Outputs Are Differential and Have LVDS Levels

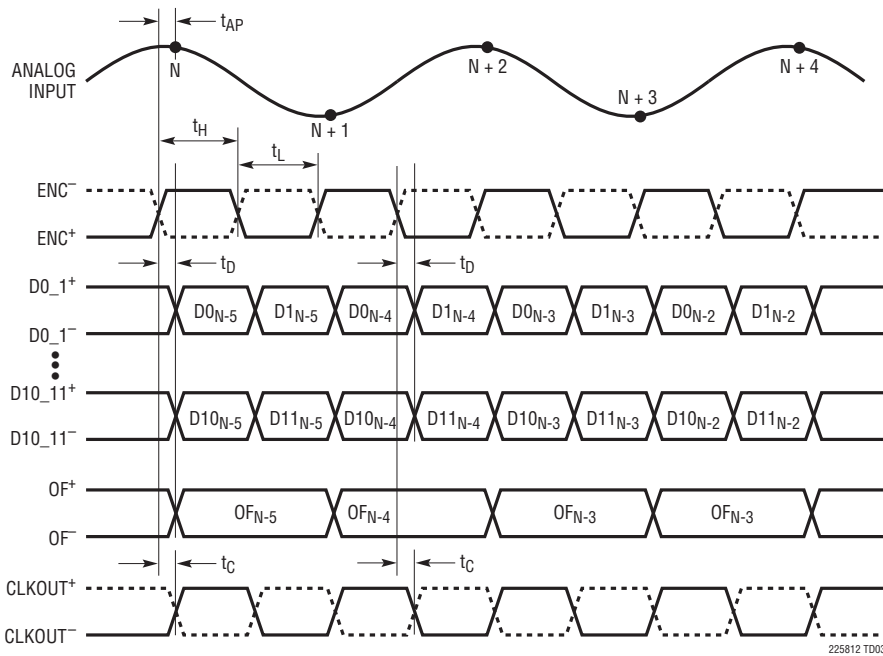

TIMING DIAGRAMS

SPI Port Timing (Readback Mode)

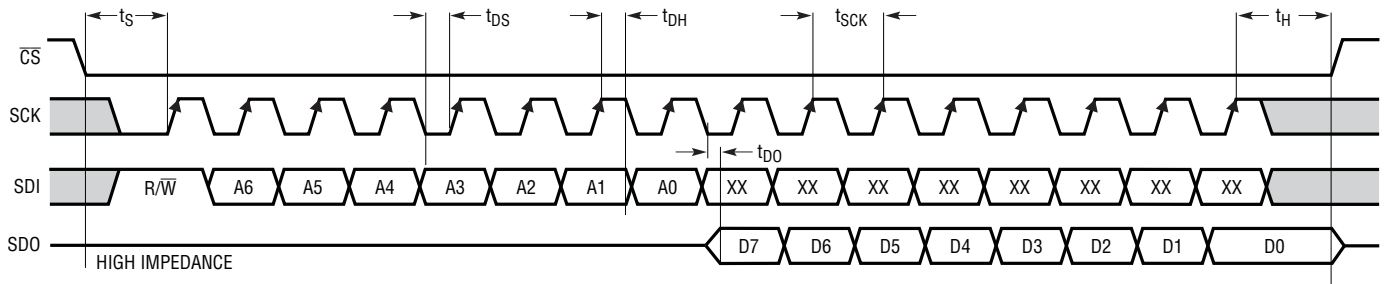

SPI Port Timing (Write Mode)

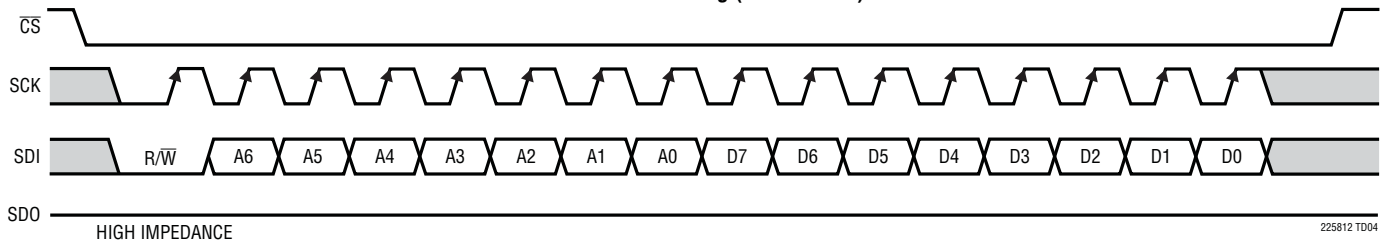

225812 T004

TYPICAL PERFORMANCE CHARACTERISTICS

LTC2258-12: Integral Nonlinearity (INL)

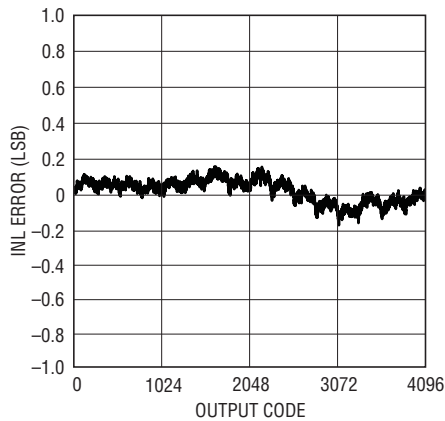

225812 G01

LTC2258-12: Differential Nonlinearity (DNL)

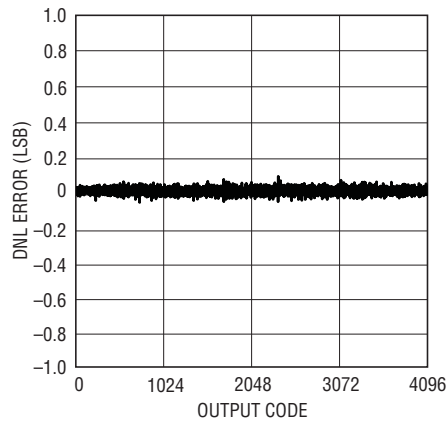

225812 G02

LTC2258-12: 8k Point FFT, $f_{IN} = 5\text{MHz}$
-1dBFS, 65Msps

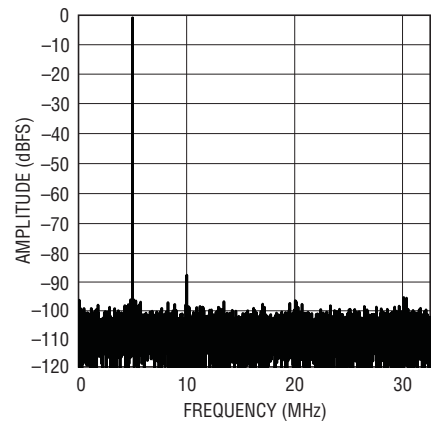

225812 G03

TYPICAL PERFORMANCE CHARACTERISTICS

LTC2258-12: 8k Point FFT, $f_{IN} = 30\text{MHz}$
-1dBFS, 65Mps

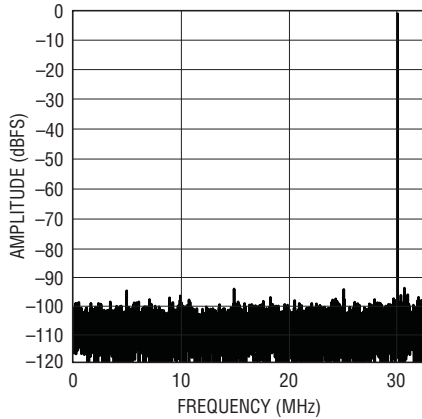

225812 G04

LTC2258-12: 8k Point FFT, $f_{IN} = 70\text{MHz}$
-1dBFS, 65Mps

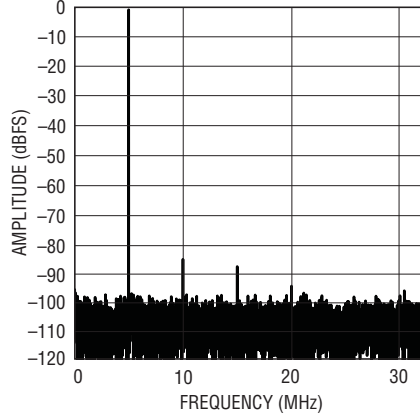

225812 G05

LTC2258-12: 8k Point FFT, $f_{IN} = 140\text{MHz}$
-1dBFS, 65Mps

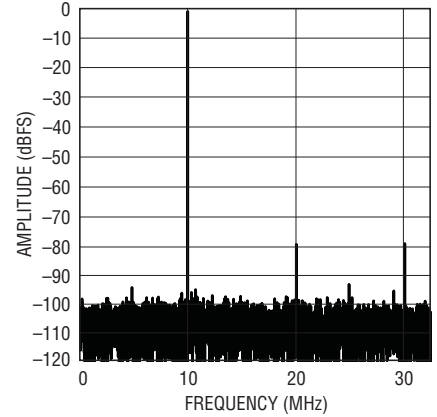

225812 G06

LTC2258-12: 8k Point 2-Tone FFT,
 $f_{IN} = 68\text{MHz}, 69\text{MHz}$, -1dBFS,
65Mps

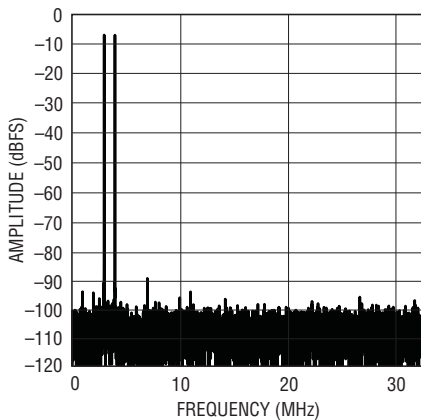

225812 G07

LTC2258-12: Shorted Input
Histogram

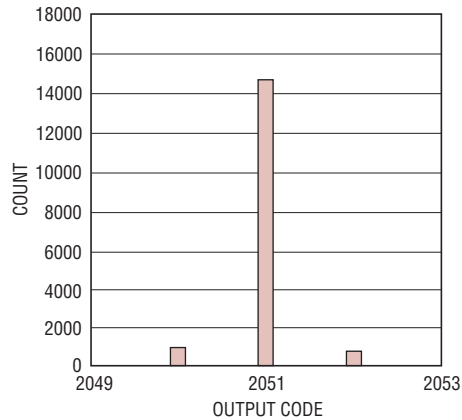

225812 G08

LTC2258-12: SNR vs Input
Frequency, -1dB, 2V Range,
65Mps

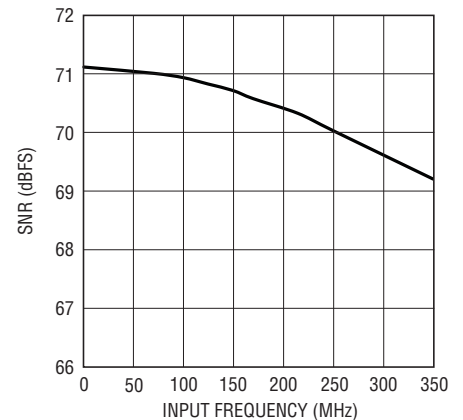

225812 G09

LTC2258-12: SFDR vs Input
Frequency, -1dB, 2V Range,
65Mps

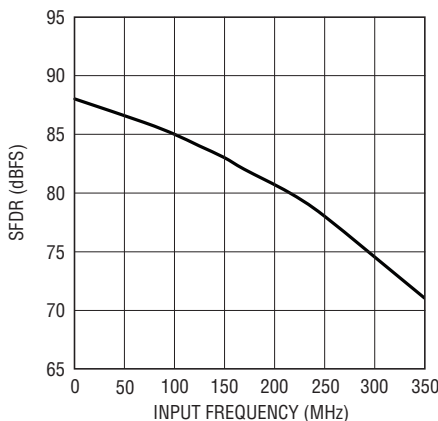

225812 G10

LTC2258-12: SFDR vs Input Level,
 $f_{IN} = 70\text{MHz}$, 2V Range, 65Mps

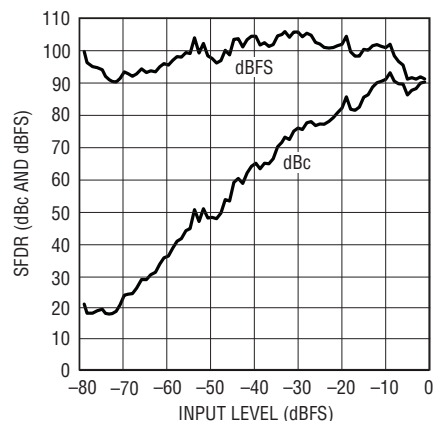

225812 G12

LTC2258-12: I_{VDD} vs Sample Rate,
5MHz Sine Wave Input, -1dB

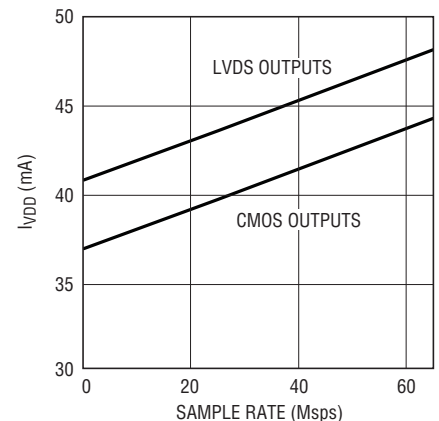

225812 G13

TYPICAL PERFORMANCE CHARACTERISTICS

LTC2258-12: I_{O_VDD} vs Sample Rate, 5MHz Sine Wave Input, -1dB, 5pF on Each Data Output

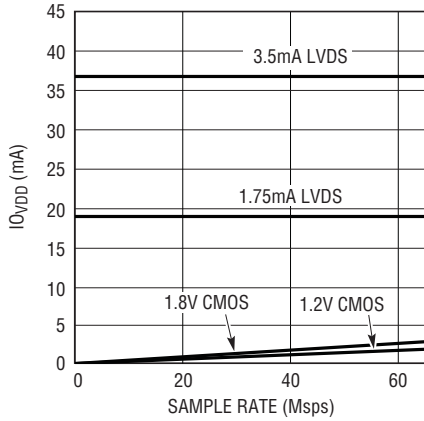

225812 G14

LTC2258-12: SNR vs SENSE, $f_{IN} = 5\text{MHz}$, -1dB

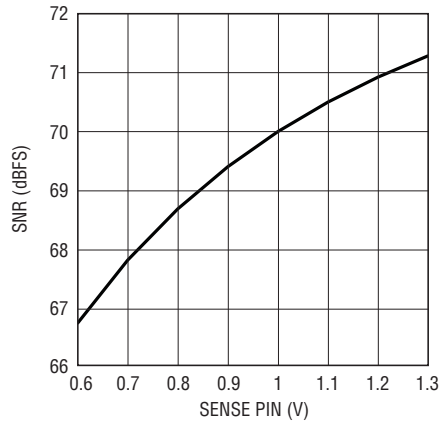

225812 G15

LTC2257-12: Integral Nonlinearity (INL)

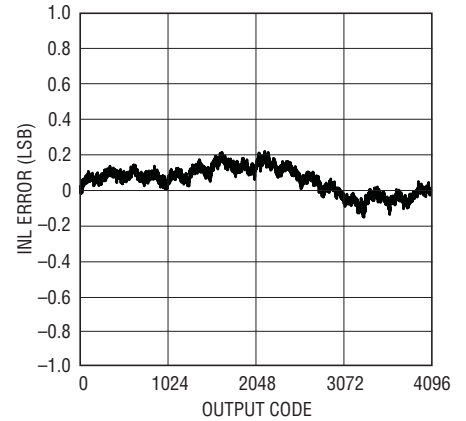

225812 G21

LTC2257-12: Differential Nonlinearity (DNL)

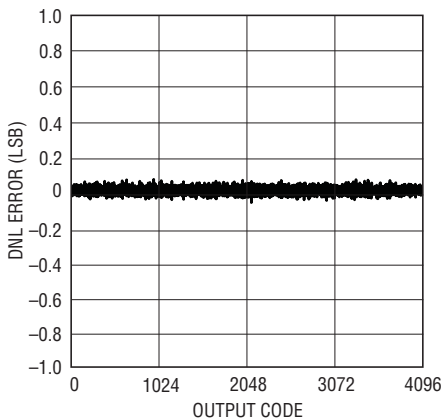

225812 G22

LTC2257-12: 8k Point FFT, $f_{IN} = 5\text{MHz}$, -1dBFS, 40MSPS

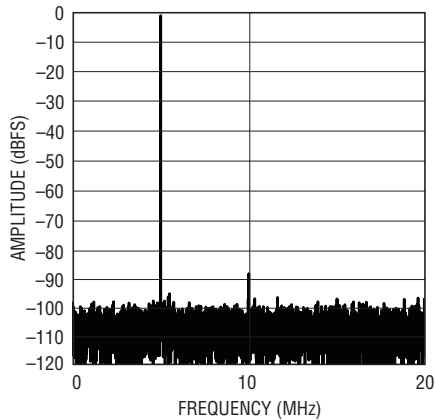

225812 G23

LTC2257-12: 8k Point FFT, $f_{IN} = 30\text{MHz}$, -1dBFS, 40MSPS

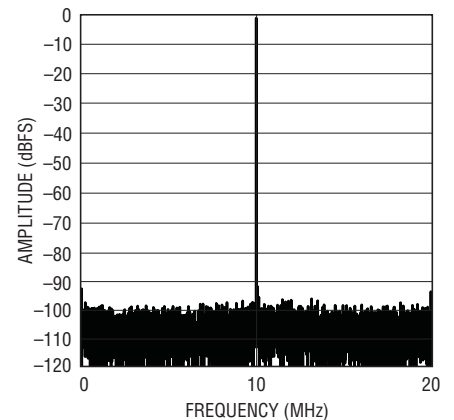

225812 G24

LTC2257-12: 8k Point FFT, $f_{IN} = 70\text{MHz}$, -1dBFS, 40MSPS

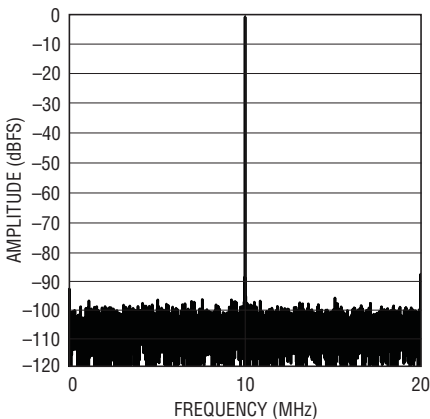

225812 G25

LTC2257-12: 8k Point FFT, $f_{IN} = 137\text{MHz}$, -1dBFS, 40MSPS

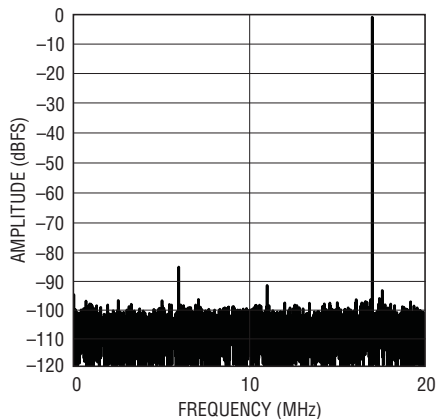

225812 G26

LTC2257-12: 8k Point 2-Tone FFT, $f_{IN} = 68\text{MHz}$, 69MHz, -1dBFS, 40MSPS

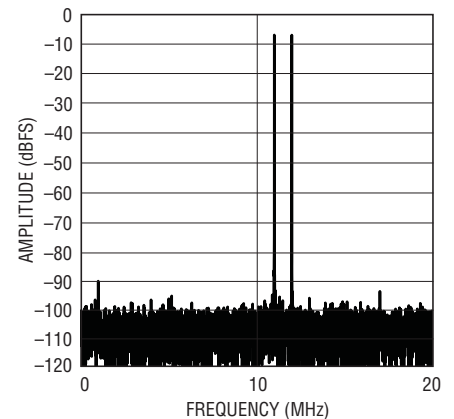

225812 G27

225812p

TYPICAL PERFORMANCE CHARACTERISTICS

LTC2257-12: Shorted Input Histogram

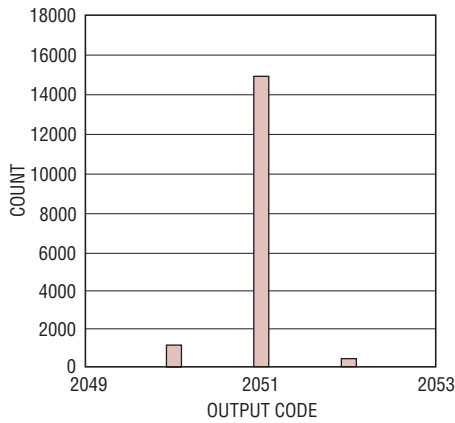

225812 G28

LTC2257-12: SNR vs Input Frequency, -1dB, 2V Range, 40Mps

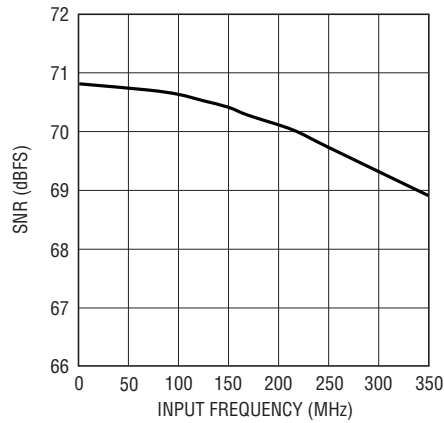

225812 G29

LTC2257-12: SFDR vs Input Frequency, -1dB, 2V Range, 40Mps

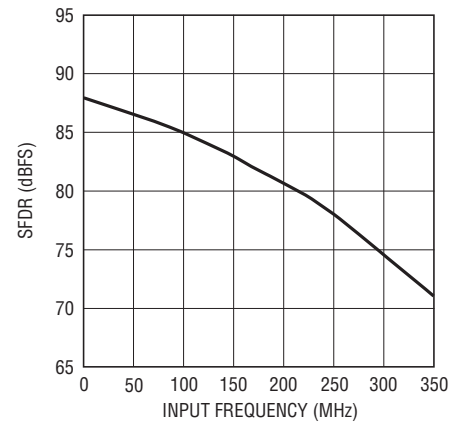

225812 G30

LTC2257-12: SFDR vs Input Level, $f_{IN} = 70\text{MHz}$, 2V Range, 40Mps

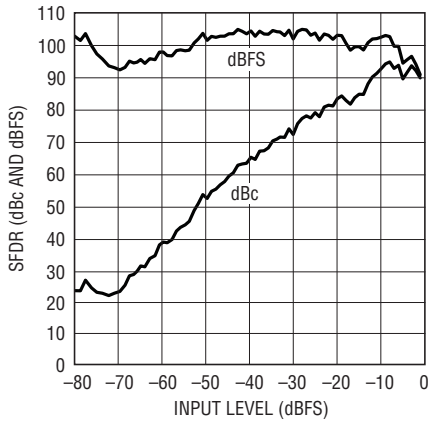

225812 G32

LTC2257-12: I_{VDD} vs Sample Rate, 5MHz Sine Wave Input, -1dB

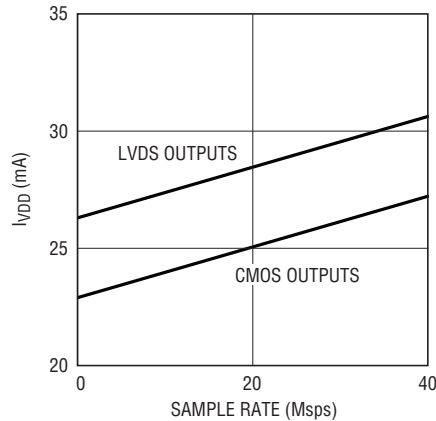

225812 G33

LTC2257-12: $I_{O_{VDD}}$ vs Sample Rate, 5MHz Sine Wave Input, -1dB, 5pF on Each Data Output

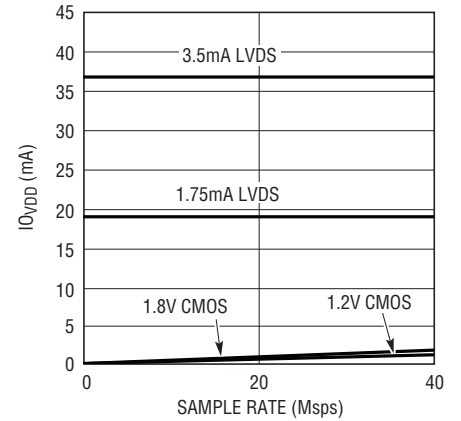

225812 G34

LTC2257-12: SNR vs SENSE, $f_{IN} = 5\text{MHz}$, -1dB

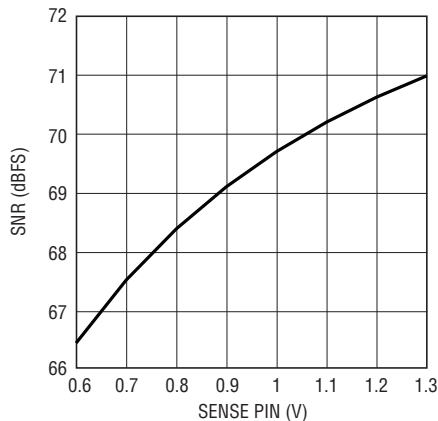

225812 G35

LTC2256-12: Integral Nonlinearity (INL)

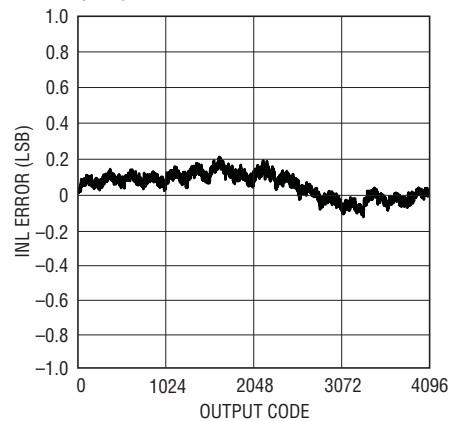

225812 G41

LTC2256-12: Differential Nonlinearity (DNL)

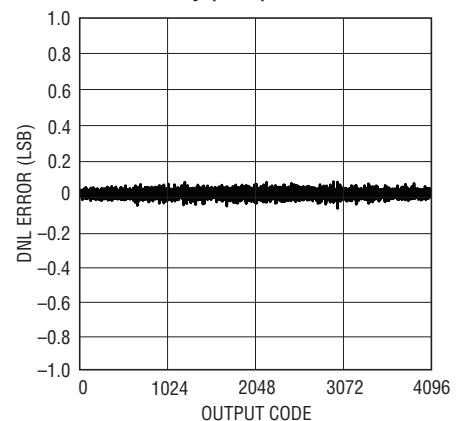

225812 G42
225812p

TYPICAL PERFORMANCE CHARACTERISTICS

LTC2256-12: 8k Point FFT, $f_{IN} = 5\text{MHz}$
-1dBFS, 25Mps

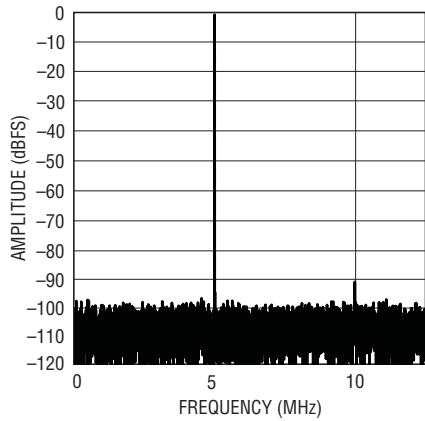

225812 G43

LTC2256-12: 8k Point FFT, $f_{IN} = 30\text{MHz}$
-1dBFS, 25Mps

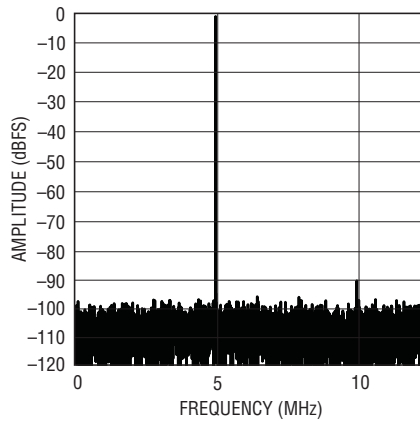

225812 G44

LTC2256-12: 8k Point FFT, $f_{IN} = 70\text{MHz}$
-1dBFS, 25Mps

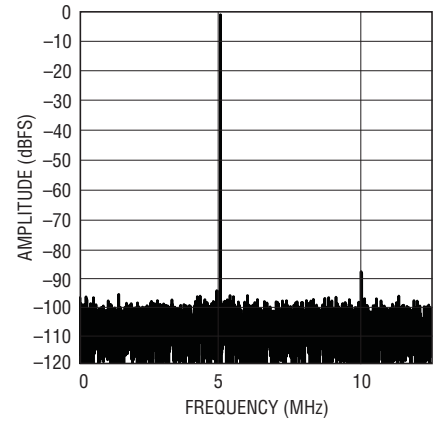

225812 G45

LTC2256-12: 8k Point FFT, $f_{IN} = 140\text{MHz}$
-1dBFS, 25Mps

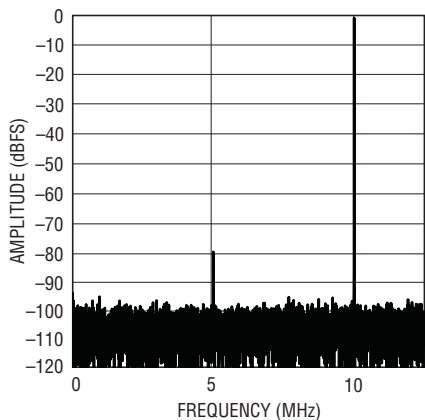

225814 G46

LTC2256-12: 8k Point 2-Tone FFT,
 $f_{IN} = 68\text{MHz}, 69\text{MHz}$, -1dBFS,
25Mps

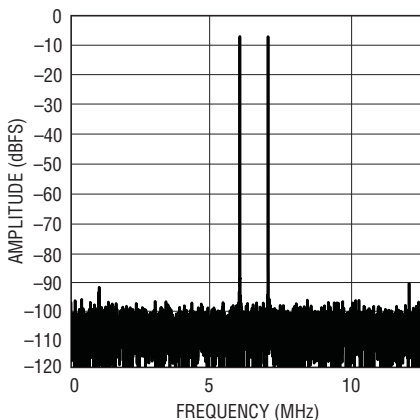

225814 G47

LTC2256-12: Shorted Input
Histogram

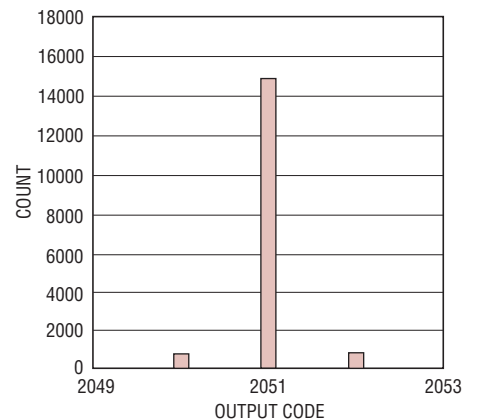

225812 G48

LTC2256-12: SNR vs Input
Frequency, -1dB, 2V Range,
25Mps

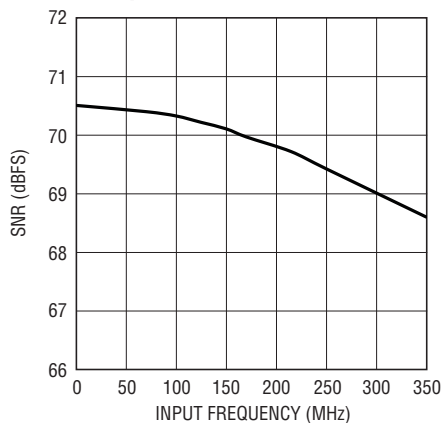

225812 G49

LTC2256-12: SFDR vs Input
Frequency, -1dB, 2V Range,
25Mps

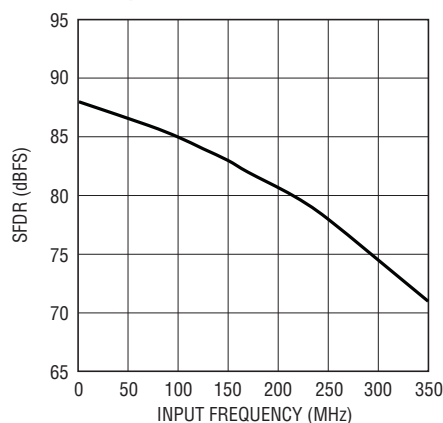

225812 G50

LTC2256-12: SFDR vs Input Level,
 $f_{IN} = 70\text{MHz}$, 2V Range, 25Mps

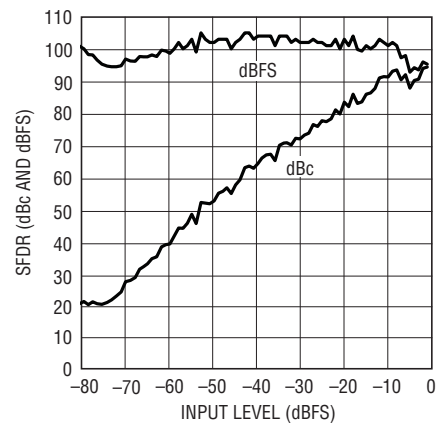

225812 G52

225812p

TYPICAL PERFORMANCE CHARACTERISTICS

LTC2256-12: I_{VDD} vs Sample Rate,
5MHz Sine Wave Input, -1dB

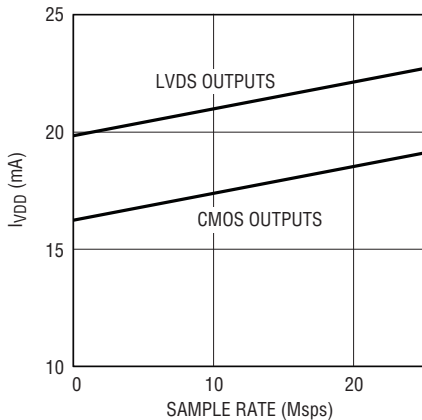

226112 G53

LTC2256-12: I_{VDD} vs Sample Rate,
5MHz Sine Wave Input, -1dB, 5pF
on Each Data Output

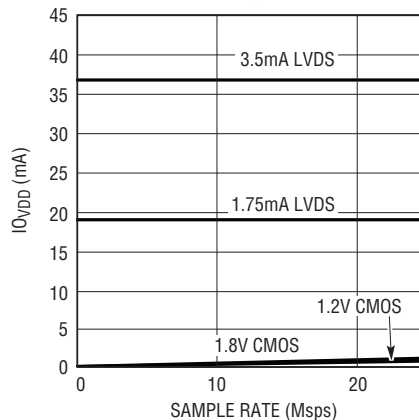

225812 G54

LTC2256-12: SNR vs SENSE,
 $f_{IN} = 5\text{MHz}$, -1dB

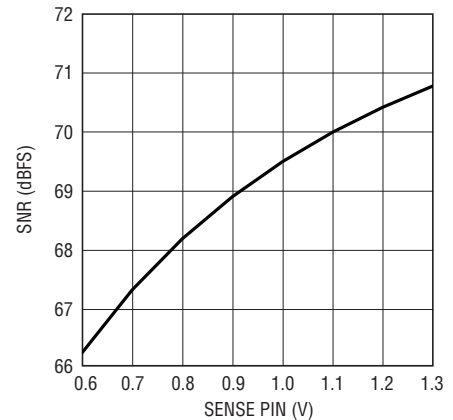

225812 G55

PIN FUNCTIONS

PINS THAT ARE THE SAME FOR ALL DIGITAL OUTPUT MODES

A_{IN}^+ (Pin 1): Positive Differential Analog Input.

A_{IN}^- (Pin 2): Negative Differential Analog Input.

GND (Pin 3): ADC Power Ground.

REFH (Pins 4, 5): ADC High Reference. Bypass to Pins 6, 7 with a 2.2 μF ceramic capacitor and to ground with a 0.1 μF ceramic capacitor.

REFL (Pins 6, 7): ADC Low Reference. Bypass to Pins 4, 5 with a 2.2 μF ceramic capacitor and to ground with a 0.1 μF ceramic capacitor.

PAR/ $\overline{\text{SER}}$ (Pin 8): Programming Mode Selection Pin. Connect to ground to enable the serial programming mode. $\overline{\text{CS}}$, SCK, SDI, SDO become a serial interface that control the A/D operating modes. Connect to V_{DD} to enable the parallel programming mode where $\overline{\text{CS}}$, SCK, SDI become parallel logic inputs that control a reduced set of the A/D operating modes. PAR/ $\overline{\text{SER}}$ should be connected directly to ground or the V_{DD} of the part and not be driven by a logic signal.

V_{DD} (Pins 9, 10, 40): 1.8V Analog Power Supply. Bypass to ground with 0.1 μF ceramic capacitors. Pins 9 and 10 can share a bypass capacitor.

ENC $^+$ (Pin 11): Encode Input. Conversion starts on the rising edge.

ENC $^-$ (Pin 12): Encode Complement Input. Conversion starts on the falling edge.

$\overline{\text{CS}}$ (Pin 13): In serial programming mode, (PAR/ $\overline{\text{SER}} = 0\text{V}$), $\overline{\text{CS}}$ is the serial interface chip select input. When $\overline{\text{CS}}$ is low, SCK is enabled for shifting data on SDI into the mode control registers. In the parallel programming mode (PAR/ $\overline{\text{SER}} = V_{DD}$), $\overline{\text{CS}}$ controls the clock duty cycle stabilizer. When $\overline{\text{CS}}$ is low, the clock duty cycle stabilizer is turned off. When $\overline{\text{CS}}$ is high, the clock duty cycle stabilizer is turned on. $\overline{\text{CS}}$ can be driven with 1.8V to 3.3V logic.

SCK (Pin 14): In serial programming mode, (PAR/ $\overline{\text{SER}} = 0\text{V}$), SCK is the serial interface clock input. In the parallel programming mode (PAR/ $\overline{\text{SER}} = V_{DD}$), SCK controls the digital output mode. When SCK is low, the full-rate CMOS output mode is enabled. When SCK is high, the double

PIN FUNCTIONS

data rate LVDS output mode (with 3.5mA output current) is enabled. SCK can be driven with 1.8V to 3.3V logic.

SDI (Pin 15): In serial programming mode, ($\overline{\text{PAR/SER}} = 0\text{V}$), SDI is the serial interface data input. Data on SDI is clocked into the mode control registers on the rising edge of SCK. In the parallel programming mode ($\overline{\text{PAR/SER}} = V_{\text{DD}}$), SDI can be used to power down the part. When SDI is low, the part operates normally. When SDI is high, the part enters sleep mode. SDI can be driven with 1.8V to 3.3V logic.

SDO (Pin 16): In serial programming mode, ($\overline{\text{PAR/SER}} = 0\text{V}$), SDO is the optional serial interface data output. Data on SDO is read back from the mode control registers and can be latched on the falling edge of SCK. SDO is an open-drain NMOS output that requires an external 2k pull-up resistor to 1.8V-3.3V. If read back from the mode control registers is not needed, the pull-up resistor is not necessary and SDO can be left unconnected. In the parallel programming mode ($\overline{\text{PAR/SER}} = V_{\text{DD}}$), SDO is not used and should not be connected.

OGND (Pin 25): Output Driver Ground.

OV_{DD} (Pin 26): Output Driver Supply. Bypass to ground with a 0.1 μF ceramic capacitor.

V_{CM} (Pin 37): Common Mode Bias Output, Nominally Equal to $V_{\text{DD}}/2$. V_{CM} should be used to bias the common mode of the analog inputs. Bypass to ground with a 0.1 μF ceramic capacitor.

V_{REF} (Pin 38): Reference Voltage Output. Bypass to ground with a 1 μF ceramic capacitor, nominally 1.25V.

SENSE (Pin 39): Reference Programming Pin. Connecting SENSE to V_{DD} selects the internal reference and a $\pm 1\text{V}$ input range. Connecting SENSE to ground selects the internal reference and a $\pm 0.5\text{V}$ input range. An external reference between 0.625V and 1.3V applied to SENSE selects an input range of $\pm 0.8 \cdot V_{\text{SENSE}}$.

FULL-RATE CMOS OUTPUT MODE

All Pins Below Have CMOS Output Levels (OGND to OV_{DD})

D0 to D11 (Pins 19-24, 29-34): Digital Outputs. D11 is the MSB.

CLKOUT⁻ (Pin 27): Inverted version of CLKOUT⁺.

CLKOUT⁺ (Pin 28): Data Output Clock. The digital outputs normally transition at the same time as the falling edge of CLKOUT⁺. The phase of CLKOUT⁺ can also be delayed relative to the digital outputs by programming the mode control registers.

DNC (Pins 17, 18, 35): Do not connect these pins.

OF (Pin 36): Over/Under Flow Digital Output. OF is high when an overflow or underflow has occurred.

DOUBLE DATA RATE CMOS OUTPUT MODE

All Pins Below Have CMOS Output Levels (OGND to OV_{DD})

D0_1 to D10_11 (Pins 20, 22, 24, 30, 32, 34): Double Data Rate Digital Outputs. Two data bits are multiplexed onto each output pin. The even data bits (D0, D2, D4, D6, D8, D10) appear when CLKOUT⁺ is low. The odd data bits (D1, D3, D5, D7, D9, D11) appear when CLKOUT⁺ is high.

CLKOUT⁻ (Pin 27): Inverted version of CLKOUT⁺.

CLKOUT⁺ (Pin 28): Data Output Clock. The digital outputs normally transition at the same time as the falling and rising edges of CLKOUT⁺. The phase of CLKOUT⁺ can also be delayed relative to the digital outputs by programming the mode control registers.

DNC (Pins 17, 18, 19, 21, 23, 29, 31, 33, 35): Do not connect these pins.

OF (Pin 36): Over/Under Flow Digital Output. OF is high when an overflow or underflow has occurred.

PIN FUNCTIONS

DOUBLE DATA RATE LVDS OUTPUT MODE

All Pins Below Have LVDS Output Levels. The Output Current Level is Programmable. There is an Optional Internal 100Ω Termination Resistor Between the Pins of Each LVDS Output Pair.

D0_1-/D0_1+ to D10_11-/D10_11+ (Pins 19/20, 21/22, 23/24, 29/30, 31/32, 33/34): Double Data Rate Digital Outputs. Two data bits are multiplexed onto each differential output pair. The even data bits (D0, D2, D4, D6, D8, D10)

appear when CLKOUT+ is low. The odd data bits (D1, D3, D5, D7, D9, D11) appear when CLKOUT+ is high.

CLKOUT-/CLKOUT+ (Pins 27/28): Data Output Clock. The digital outputs normally transition at the same time as the falling and rising edges of CLKOUT+. The phase of CLKOUT+ can also be delayed relative to the digital outputs by programming the mode control registers.

OF-/OF+ (Pins 35/36): Over/Under Flow Digital Output. OF+ is high when an overflow or underflow has occurred.

FUNCTIONAL BLOCK DIAGRAM

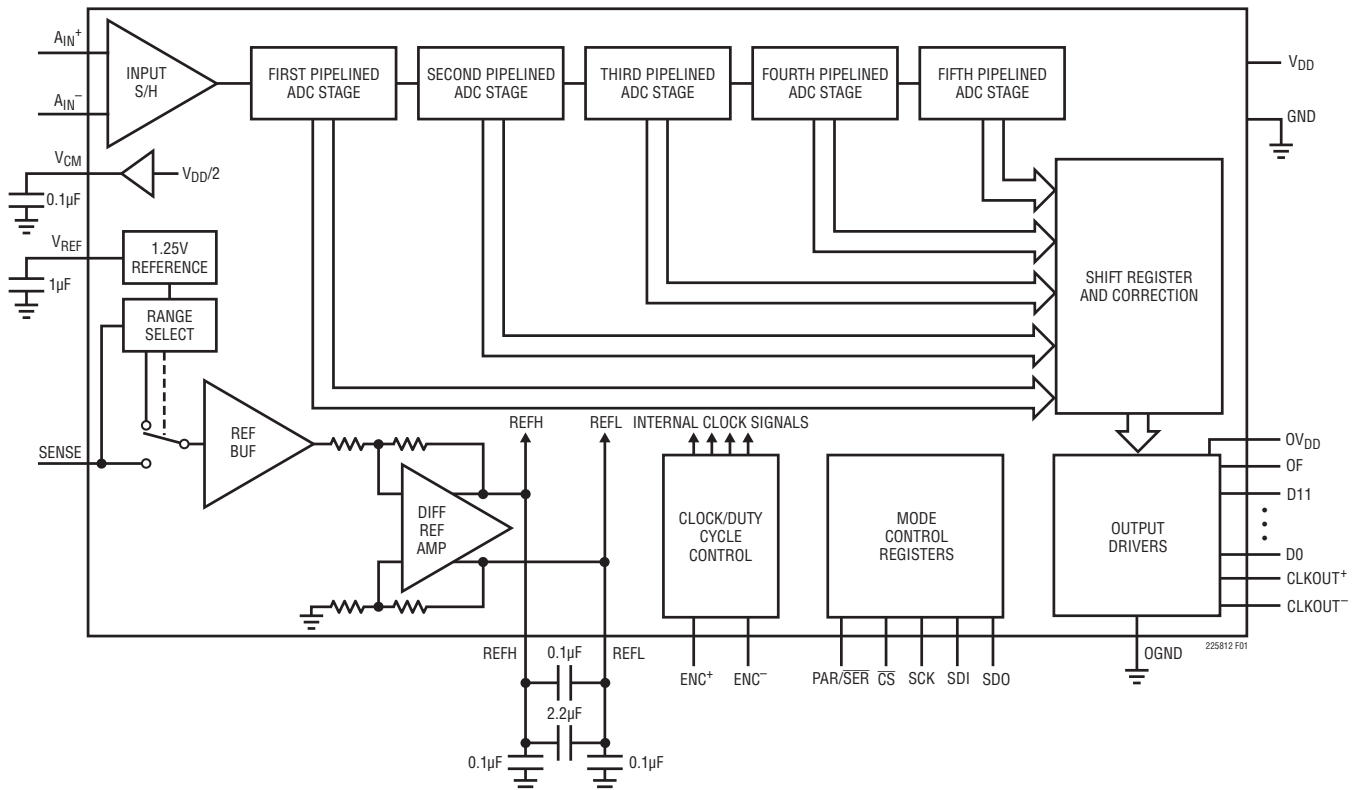

Figure 1. Functional Block Diagram

APPLICATIONS INFORMATION

CONVERTER OPERATION

The LTC2258-12/LTC2257-12/LTC2256-12 are low power 12-bit 65Msps/40Msps/25Msps A/D converters that are powered by a single 1.8V supply. The analog inputs should be driven differentially. The encode input can be driven differentially or single-ended for lower power consumption. The digital outputs can be CMOS, double data rate CMOS (to halve the number of output lines), or double data rate LVDS (to reduce digital noise in the system.) Many additional features can be chosen by programming the mode control registers through a serial SPI port. See the Serial Programming Mode section.

ANALOG INPUT

The analog input is a differential CMOS sample-and-hold circuit (Figure 2). The inputs should be driven differentially around a common mode voltage set by the V_{CM} output pin, which is nominally $V_{DD}/2$. For the 2V input range, the

inputs should swing from $V_{CM} - 0.5V$ to $V_{CM} + 0.5V$. There should be 180° phase difference between the inputs.

INPUT DRIVE CIRCUITS

Input filtering

If possible, there should be an RC lowpass filter right at the analog inputs. This lowpass filter isolates the drive circuitry from the A/D sample-and-hold switching, and also limits wideband noise from the drive circuitry. Figure 3 shows an example of an input RC filter. The RC component values should be chosen based on the application's input frequency.

Transformer Coupled Circuits

Figure 3 shows the analog input being driven by an RF transformer with a center-tapped secondary. The center tap is biased with V_{CM} , setting the A/D input at its optimal DC level. At higher input frequencies a transmission line

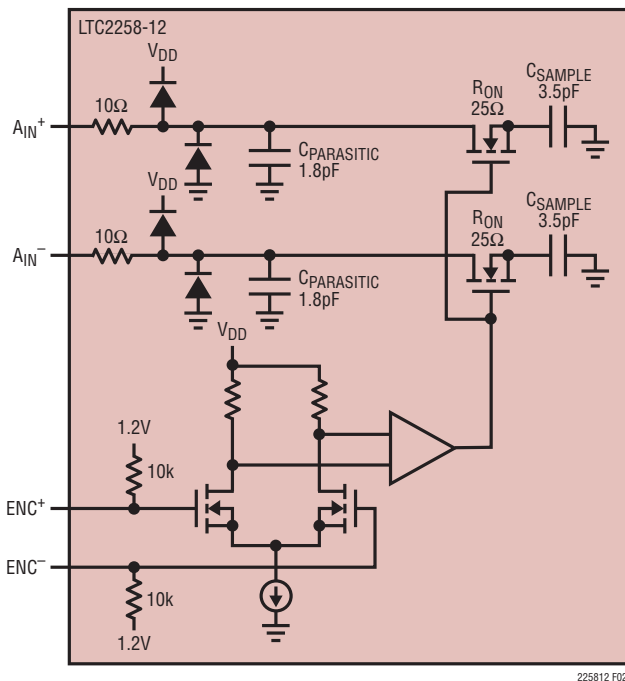

Figure 2. Equivalent Input Circuit

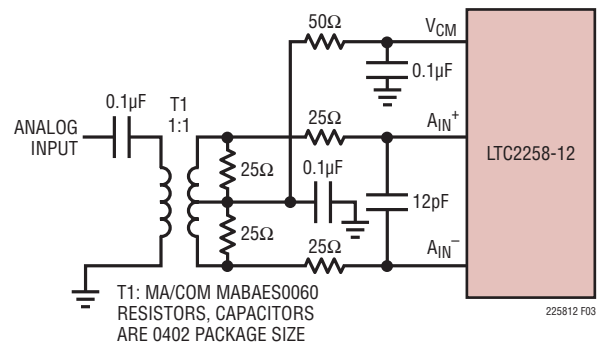

Figure 3. Analog Input Circuit Using a Transformer.
Recommended for Input Frequencies from 5MHz to 70MHz

APPLICATIONS INFORMATION

balun transformer (Figures 4 to 6) has better balance, resulting in lower A/D distortion.

Amplifier Circuits

Figure 7 shows the analog input being driven by a high speed differential amplifier. The output of the amplifier is AC coupled to the A/D so the amplifier's output common mode voltage can be optimally set to minimize distortion.

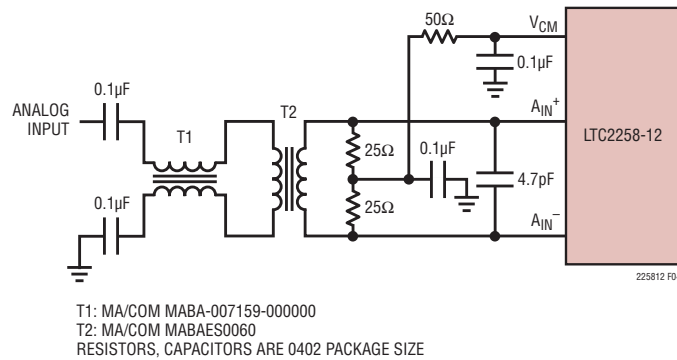

Figure 4. Recommended Front-End Circuit for Input Frequencies from 70MHz to 170MHz

At very high frequencies an RF gain block will often have lower distortion than a differential amplifier. If the gain block is single-ended, then a transformer circuit (Figures 4 to 6) should convert the signal to differential before driving the A/D.

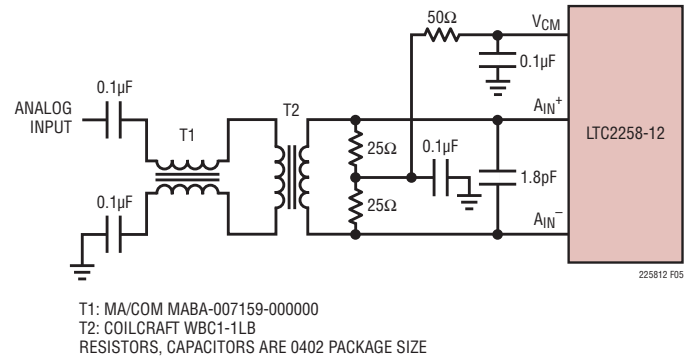

Figure 5. Recommended Front-End Circuit for Input Frequencies from 170MHz to 270MHz

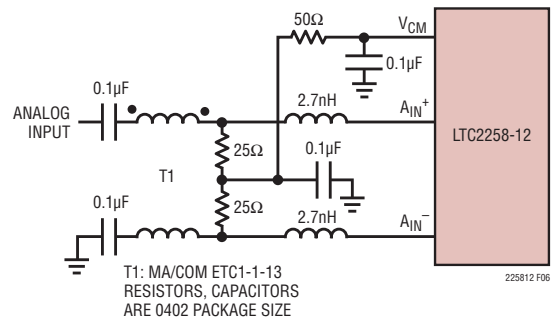

Figure 6. Recommended Front-End Circuit for Input Frequencies Above 270MHz

APPLICATIONS INFORMATION

Reference

The LTC2258-12/2257-12/2256-12 has an internal 1.25V voltage reference. For a 2V input range using the internal reference, connect SENSE to V_{DD} . For a 1V input range using the external reference, connect SENSE to ground. For a 2V input range with an external reference, apply a 1.25V reference voltage to SENSE (Figure 9.)

The input range can be adjusted by applying a voltage to SENSE that is between 0.625V and 1.30V. The input range will then be $1.6 \cdot V_{SENSE}$.

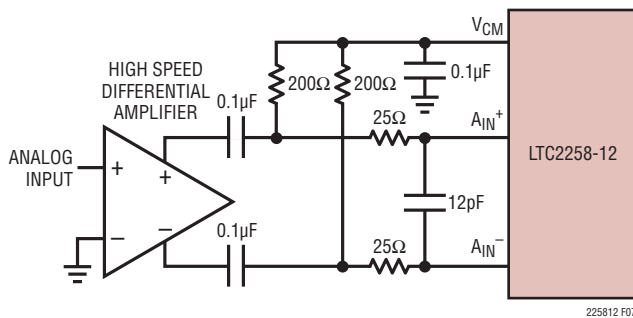

Figure 7. Front-End Circuit Using a High Speed Differential Amplifier

The V_{REF} , REFH and REFL pins should be bypassed as shown in Figure 8. The 0.1µF capacitor between REFH and REFL should be as close to the pins as possible (not on the back side of the circuit board).

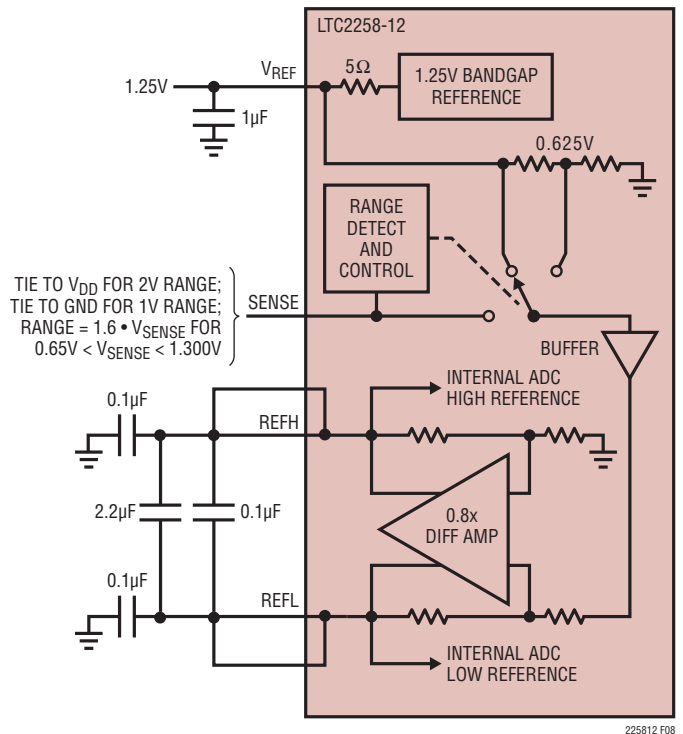

Figure 8. Reference Circuit

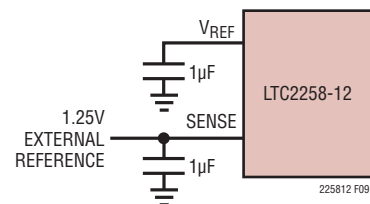

Figure 9. Using an External 1.25V Reference

APPLICATIONS INFORMATION

Encode Input

The signal quality of the encode inputs strongly affects the A/D noise performance. The encode inputs should be treated as analog signals—do not route them next to digital traces on the circuit board. There are two modes of operation for the encode inputs: the differential encode mode (Figure 10) and the single-ended encode mode (Figure 11).

The differential encode mode is recommended for sinusoidal, PECL or LVDS encode inputs (Figures 12, 13). The encode inputs are internally biased to 1.2V through 10k equivalent resistance. The encode inputs can be taken above V_{DD} (up to 3.6V), and the common mode range is from 1.1V to 1.6V. In the differential encode mode, ENC^- should stay at least 200mV above ground to avoid falsely triggering the single-ended encode mode. For good jitter performance ENC^+ and ENC^- should have fast rise and fall times.

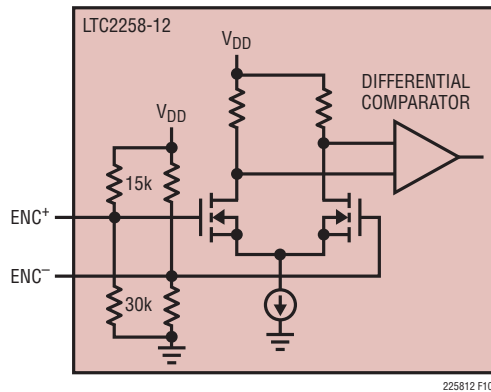

Figure 10. Equivalent Encode Input Circuit for Differential Encode Mode

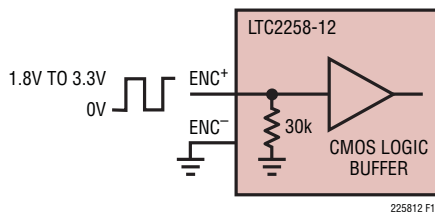

Figure 11. Equivalent Encode Input Circuit for Single-Ended Encode Mode

The single-ended encode mode should be used with CMOS encode inputs. To select this mode, ENC^- is connected to ground and ENC^+ is driven with a square wave encode input. ENC^+ can be taken above V_{DD} (up to 3.6V) so 1.8V to 3.3V CMOS logic levels can be used. The ENC^+ threshold is 0.9V. For good jitter performance ENC^+ should have fast rise and fall times.

Clock Duty Cycle Stabilizer

For good performance the encode signal should have a 50% ($\pm 5\%$) duty cycle. If the optional clock duty cycle stabilizer circuit is enabled, the encode duty cycle can vary from 30% to 70% and the duty cycle stabilizer will maintain a constant 50% internal duty cycle. If the encode signal changes frequency or is turned off, the duty cycle stabilizer circuit requires one hundred clock cycles to lock onto the input clock. The duty cycle stabilizer is enabled by mode control register A2 (serial programming mode), or by \overline{CS} (parallel programming mode).

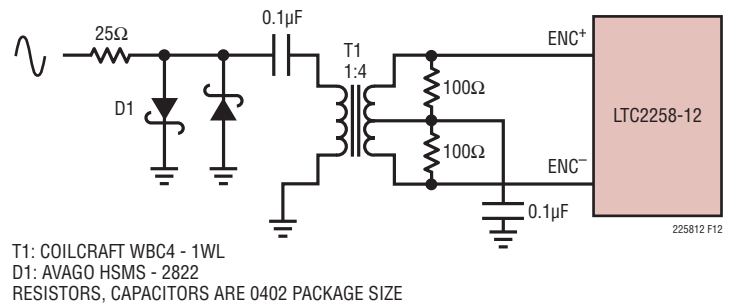

Figure 12. Sinusoidal Encode Drive

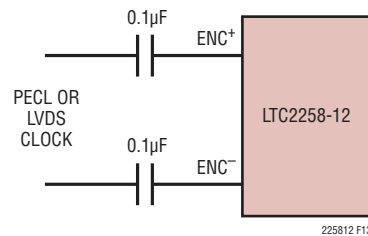

Figure 13. PECL or LVDS Encode Drive

APPLICATIONS INFORMATION

For applications where the sample rate needs to be changed quickly, the clock duty cycle stabilizer can be disabled. If the duty cycle stabilizer is disabled, care should be taken to make the sampling clock have a 50% ($\pm 5\%$) duty cycle. The duty cycle stabilizer should not be used below 5Msps.

DIGITAL OUTPUTS

Digital Output Modes

The LTC2258-12/LTC2257-12/LTC2256-12 can operate in three digital output modes: full rate CMOS, double data rate CMOS (to halve the number of output lines), or double data rate LVDS (to reduce digital noise in the system). The output mode is set by mode control register A3 (serial programming mode), or by SCK (parallel programming mode). Note that double data rate CMOS cannot be selected in the parallel programming mode.

Full-Rate CMOS Mode

In full-rate CMOS mode the 12 digital outputs (D0-D11), overflow (OF), and the data output clocks (CLKOUT⁺, CLKOUT⁻) have CMOS output levels. The outputs are powered by OV_{DD} and OGND which are isolated from the A/D core power and ground. OV_{DD} can range from 1.1V to 1.9V, allowing 1.2V through 1.8V CMOS logic outputs.

For good performance the digital outputs should drive minimal capacitive loads. If the load capacitance is larger than 10pF a digital buffer should be used.

Double Data Rate CMOS Mode

In double data rate CMOS mode, two data bits are multiplexed and output on each data pin. This reduces the number of data lines by seven, simplifying board routing and reducing the number of input pins needed to receive the data. The 6 digital outputs (D0_1, D2_3, D4_5, D6_7, D8_9, D10_11), overflow (OF), and the data output clocks (CLKOUT⁺, CLKOUT⁻) have CMOS output levels. The outputs are powered by OV_{DD} and OGND which are isolated from the A/D core power and ground. OV_{DD} can range from 1.1V to 1.9V, allowing 1.2V through 1.8V CMOS logic outputs.

For good performance the digital outputs should drive minimal capacitive loads. If the load capacitance is larger than 10pF a digital buffer should be used.

When using double data rate CMOS at high sample rates the SNR will degrade slightly (see Typical Performance Characteristics section). DDR CMOS is not recommended for sample frequencies above 100MHz.

Double Data Rate LVDS Mode

In double data rate LVDS mode, two data bits are multiplexed and output on each differential output pair. There are 6 LVDS output pairs (D0_1⁺/D0_1⁻ through D10_11⁺/D10_11⁻) for the digital output data. Overflow (OF⁺/OF⁻) and the data output clock (CLKOUT⁺/CLKOUT⁻) each have an LVDS output pair.

By default the outputs are standard LVDS levels: 3.5mA output current and a 1.25V output common mode voltage. An external 100 Ω differential termination resistor is required for each LVDS output pair. The termination resistors should be located as close as possible to the LVDS receiver.

The outputs are powered by OV_{DD} and OGND which are isolated from the A/D core power and ground. In LVDS mode, OV_{DD} must be 1.8V.

Programmable LVDS Output Current

In LVDS mode, the default output driver current is 3.5mA. This current can be adjusted by serially programming mode control register A3. Available current levels are 1.75mA, 2.1mA, 2.5mA, 3mA, 3.5mA, 4mA and 4.5mA.

Optional LVDS Driver Internal Termination

In most cases using just an external 100 Ω termination resistor will give excellent LVDS signal integrity. In addition, an optional internal 100 Ω termination resistor can be enabled by serially programming mode control register A3. The internal termination helps absorb any reflections caused by imperfect termination at the receiver. When the internal termination is enabled, the output driver current is increased by 1.6x to maintain about the same output voltage swing.

APPLICATIONS INFORMATION

Overflow Bit

The overflow output bit (OF) outputs a logic high when the analog input is either overranged or underranged. The overflow bit has the same pipeline latency as the data bits.

Phase Shifting the Output Clock

In full-rate CMOS mode the data output bits normally change at the same time as the falling edge of CLKOUT⁺, so the rising edge of CLKOUT⁺ can be used to latch the output data. In double data rate CMOS and LVDS modes the data output bits normally change at the same time as the falling and rising edges of CLKOUT⁺. To allow adequate setup-and-hold time when latching the data, the CLKOUT⁺ signal may need to be phase shifted relative to the data output bits. Most FPGAs have this feature; this is generally the best place to adjust the timing.

The LTC2261-12/LTC2260-12/LTC2259-12 can also phase shift the CLKOUT⁺/CLKOUT⁻ signals by serially programming mode control register A2. The output clock can be shifted by 0°, 45°, 90° or 135°. To use the phase shifting feature the clock duty cycle stabilizer must be turned

on. Another control register bit can invert the polarity of CLKOUT⁺ and CLKOUT⁻, independently of the phase shift. The combination of these two features enables phase shifts of 45° up to 315° (Figure 14).

DATA FORMAT

Table 1 shows the relationship between the analog input voltage, the digital data output bits and the overflow bit. By default the output data format is offset binary. The 2's complement format can be selected by serially programming mode control register A4.

Table 1. Output Codes vs Input Voltage

A _{IN} ⁺ – A _{IN} ⁻ (2V RANGE)	OF	D11-D0 (OFFSET BINARY)	D11-D0 (2's COMPLEMENT)
>+1.000000V	1	1111 1111 1111	0111 1111 1111
+0.999512V	0	1111 1111 1111	0111 1111 1111
+0.999024V	0	1111 1111 1110	0111 1111 1110
+0.000488V	0	1000 0000 0001	0000 0000 0001
0.000000V	0	1000 0000 0000	0000 0000 0000
-0.000488V	0	0111 1111 1111	1111 1111 1111
-0.000976V	0	0111 1111 1110	1111 1111 1110
-0.999512V	0	0000 0000 0001	1000 0000 0001
-1.000000V	0	0000 0000 0000	1000 0000 0000
≤-1.000000V	1	0000 0000 0000	1000 0000 0000

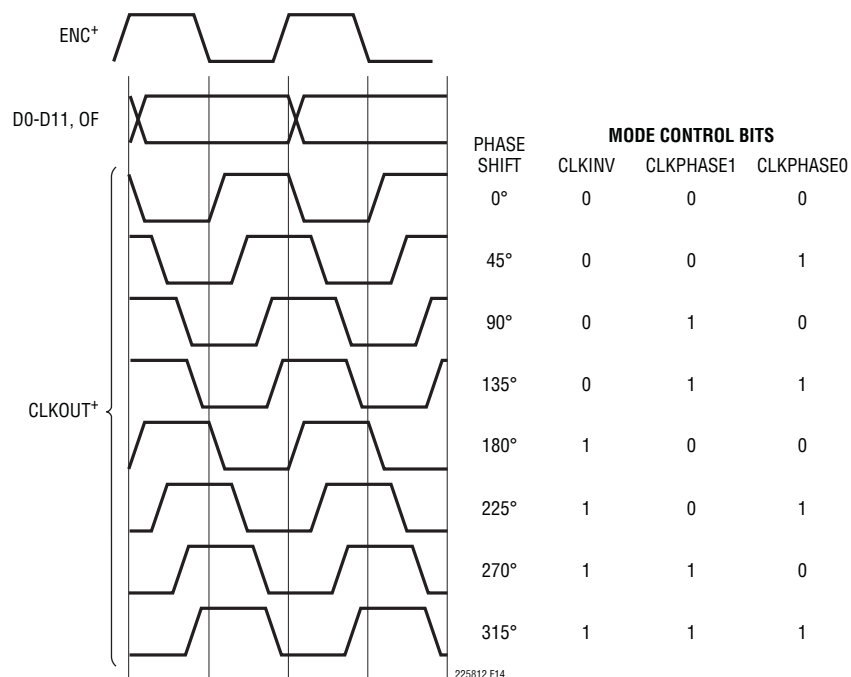

Figure 14. Phase Shifting CLKOUT

APPLICATIONS INFORMATION

Digital Output Randomizer

Interference from the A/D digital outputs is sometimes unavoidable. Digital interference may be from capacitive or inductive coupling or coupling through the ground plane. Even a tiny coupling factor can cause unwanted tones in the ADC output spectrum. By randomizing the digital output before it is transmitted off chip, these unwanted tones can be randomized which reduces the unwanted tone amplitude.

The digital output is “randomized” by applying an exclusive-OR logic operation between the LSB and all other data output bits. To decode, the reverse operation is applied—an exclusive-OR operation is applied between the LSB and all other bits. The LSB, OF and CLKOUT outputs are not affected. The output randomizer is enabled by serially programming mode control register A4.

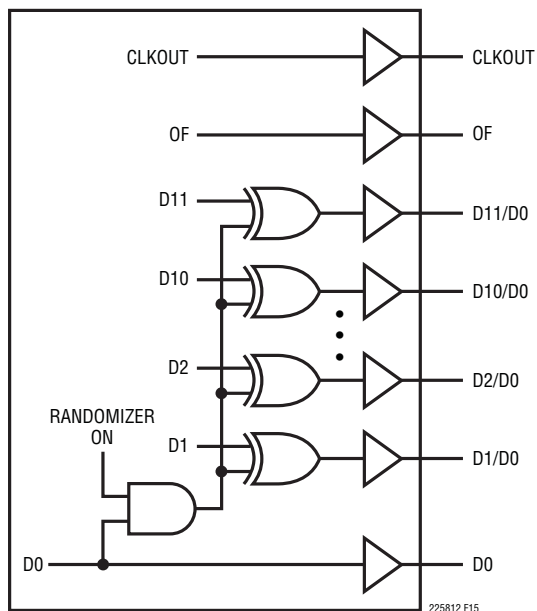

Figure 15. Functional Equivalent of Digital Output Randomizer

Alternate Bit Polarity

Another feature that reduces digital feedback on the circuit board is the alternate bit polarity mode. When this mode is enabled, all of the odd bits (D1, D3, D5, D7, D9, D11) are inverted before the output buffers. The even bits (D0, D2, D4, D6, D8, D10), OF and CLKOUT are not affected. This can reduce digital currents in the circuit board ground plane and reduce digital noise, particularly for very small analog input signals.

When there is a very small signal at the input of the A/D that is centered around midscale, the digital outputs toggle between mostly 1s and mostly 0s. This simultaneous switching of most of the bits will cause large currents in the ground plane. By inverting every other bit, the alternate bit polarity mode makes half of the bits transition high while half of the bits transition low. To first order, this cancels current flow in the ground plane, reducing the digital noise.

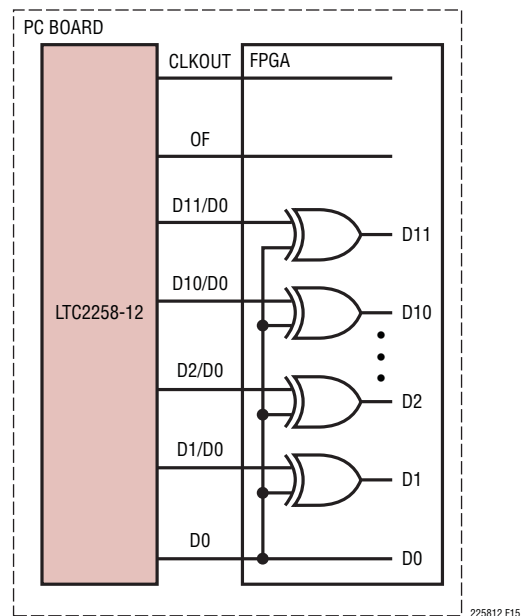

Figure 16. Unrandomizing a Randomized Digital Output Signal

APPLICATIONS INFORMATION

The digital output is decoded at the receiver by inverting the odd bits (D1, D3, D5, D7, D9, D11). The alternate bit polarity mode is independent of the digital output randomizer—either, both or neither function can be on at the same time. When alternate bit polarity mode is on, the data format is offset binary and the 2's complement control bit has no effect. The alternate bit polarity mode is enabled by serially programming mode control register A4.

Digital Output Test Patterns

To allow in-circuit testing of the digital interface to the A/D, there are several test modes that force the A/D data outputs (OF, D11-D0) to known values:

All 1s: All outputs are 1

All 0s: All outputs are 0

Alternating: Outputs change from all 1s to all 0s on alternating samples

Checkerboard: Outputs change from 101010101010 to 010101010101 on alternating samples

The digital output test patterns are enabled by serially programming mode control register A4. When enabled, the test patterns override all other formatting modes: 2's complement, randomizer, alternate-bit-polarity.

Output Disable

The digital outputs may be disabled by serially programming mode control register A3. All digital outputs including OF and CLKOUT are disabled. The high impedance disabled state is intended for long periods of inactivity—it is too slow to multiplex a data bus between multiple converters at full speed.

Sleep and Nap Modes

The A/D may be placed in sleep or nap modes to conserve power. In sleep mode the entire A/D converter is powered down, resulting in 0.5mW power consumption. Sleep mode is enabled by mode control register A1 (serial programming mode), or by SDI (parallel programming mode). The amount of time required to recover from sleep mode depends on the size of the bypass capacitors on V_{REF} ,

REFH, and REFL. For the suggested values in Figure 8, the A/D will stabilize after 2ms.

In nap mode the A/D core is powered down while the internal reference circuits stay active, allowing faster wake-up than from sleep mode. Recovering from nap mode requires at least 100 clock cycles. If the application demands very accurate DC settling then an additional 50 μ s should be allowed so the on-chip references can settle from the slight temperature shift caused by the change in supply current as the A/D leaves nap mode. Nap mode is enabled by mode control register A1 in the serial programming mode.

DEVICE PROGRAMMING MODES

The operating modes of the LTC2258-12 can be programmed by either a parallel interface or a simple serial interface. The serial interface has more flexibility and can program all available modes. The parallel interface is more limited and can only program some of the more commonly used modes.

Parallel Programming Mode

To use the parallel programming mode, $\overline{PAR/SER}$ should be tied to V_{DD} . The \overline{CS} , SCK and SDI pins are binary logic inputs that set certain operating modes. These pins can be tied to V_{DD} or ground, or driven by 1.8V, 2.5V or 3.3V CMOS logic. Table 2 shows the modes set by \overline{CS} , SCK and SDI.

Table 2. Parallel Programming Mode Control Bits ($\overline{PAR/SER} = V_{DD}$)

PIN	DESCRIPTION
\overline{CS}	Clock Duty Cycle Stabilizer Control Bit 0 = Clock Duty Cycle Stabilizer Off 1 = Clock Duty Cycle Stabilizer On
SCK	Digital Output Mode Control Bit 0 = Full-Rate CMOS Output Mode 1 = Double Data Rate LVDS Output Mode (3.5mA LVDS Current, Internal Termination Off)
SDI	Power Down Control Bit 0 = Normal Operation 1 = Sleep Mode

APPLICATIONS INFORMATION

Serial Programming Mode

To use the serial programming mode, $\overline{\text{PAR}}/\overline{\text{SER}}$ should be tied to ground. The $\overline{\text{CS}}$, SCK, SDI and SDO pins become a serial interface that program the A/D mode control registers. Data is written to a register with a 16-bit serial word. Data can also be read back from a register to verify its contents.

Serial data transfer starts when $\overline{\text{CS}}$ is taken low. The data on the SDI pin is latched at the first 16 rising edges of SCK. Any SCK rising edges after the first 16 are ignored. The data transfer ends when $\overline{\text{CS}}$ is taken high again.

The first bit of the 16-bit input word is the $\text{R}/\overline{\text{W}}$ bit. The next seven bits are the address of the register (A6:A0). The final eight bits are the register data (D7:D0).

If the $\text{R}/\overline{\text{W}}$ bit is low, the serial data (D7:D0) will be written to the register set by the address bits (A6:A0). If the $\text{R}/\overline{\text{W}}$ bit is high, data in the register set by the address bits (A6:A0) will be read back on the SDO pin (see the timing

diagrams). During a read back command the register is not updated and data on SDI is ignored.

The SDO pin is an open-drain output that pulls to ground with a 200 Ω impedance. If register data is read back through SDO, an external 2k pull-up resistor is required. If serial data is only written and read back is not needed, then SDO can be left floating and no pull-up resistor is needed.

Table 3 shows a map of the mode control registers.

Software Reset

If serial programming is used, the mode control registers should be programmed as soon as possible after the power supplies turn on and are stable. The first serial command must be a software reset which will reset all register data bits to logic 0. To perform a software reset, bit D7 in the reset register is written with a logic 1. After the reset is complete, bit D7 is automatically set back to zero.

Table 3. Serial Programming Mode Register Map

REGISTER A0: RESET REGISTER (ADDRESS 00h)

D7	D6	D5	D4	D3	D2	D1	D0
RESET	X	X	X	X	X	X	X

Bit 7 **RESET** Software Reset Bit
 0 = Not Used
 1 = Software Reset. All Mode Control Registers are Reset to 00h. This Bit is Automatically Set Back to Zero After the Reset is Complete

Bits 6-0 Unused, Don't Care Bits.

REGISTER A1: POWER-DOWN REGISTER (ADDRESS 01h)

D7	D6	D5	D4	D3	D2	D1	D0
X	X	X	X	X	X	PWROFF1	PWROFF0

Bits 7-2 Unused, Don't Care Bits.

Bits 1-0 **PWROFF1:PWROFF0** Power Down Control Bits
 00 = Normal Operation
 01 = Nap Mode
 10 = Not Used
 11 = Sleep Mode

APPLICATIONS INFORMATION

REGISTER A2: TIMING REGISTER (ADDRESS 02h)

D7	D6	D5	D4	D3	D2	D1	D0
X	X	X	X	CLKINV	CLKPHASE1	CLKPHASE0	DCS

Bits 7-4

Unused, Don't Care Bits.

Bit 3

CLKINV Output Clock Invert Bit
0 = Normal CLKOUT Polarity (As Shown in the Timing Diagrams)
1 = Inverted CLKOUT Polarity

Bits 2-1

CLKPHASE1:CLKPHASE0 Output Clock Phase Delay Bits
00 = No CLKOUT Delay (As Shown in the Timing Diagrams)
01 = CLKOUT+/CLKOUT- Delayed by 45° (Clock Period • 1/8)
10 = CLKOUT+/CLKOUT- Delayed by 90° (Clock Period • 1/4)
11 = CLKOUT+/CLKOUT- Delayed by 135° (Clock Period • 3/8)
Note: If the CLKOUT Phase Delay Feature is Used, the Clock Duty Cycle Stabilizer Must Also be Turned On

Bit 0

DCS Clock Duty Cycle Stabilizer Bit
0 = Clock Duty Cycle Stabilizer Off
1 = Clock Duty Cycle Stabilizer On

REGISTER A3: OUTPUT MODE REGISTER (ADDRESS 03h)

D7	D6	D5	D4	D3	D2	D1	D0
X	ILVDS2	ILVDS1	ILVDS0	TERMON	OUTOFF	OUTMODE1	OUTMODE0

Bit 7

Unused, Don't Care Bit.

Bits 6-4

ILVDS2:ILVDS0 LVDS Output Current Bits
000 = 3.5mA LVDS Output Driver Current
001 = 4.0mA LVDS Output Driver Current
010 = 4.5mA LVDS Output Driver Current
011 = Not Used
100 = 3.0mA LVDS Output Driver Current
101 = 2.5mA LVDS Output Driver Current
110 = 2.1mA LVDS Output Driver Current
111 = 1.75mA LVDS Output Driver Current

Bit 3

TERMON LVDS Internal Termination Bit
0 = Internal Termination Off
1 = Internal Termination On. LVDS Output Driver Current is 1.6x the Current Set by ILVDS2:ILVDS0

Bit 2

OUTOFF Output Disable Bit
0 = Digital Outputs are Enabled
1 = Digital Outputs are Disabled and Have High Output Impedance

Bits 1-0

OUTMODE1:OUTMODE0 Digital Output Mode Control Bits
00 = Full-Rate CMOS Output Mode
01 = Double Data Rate LVDS Output Mode
10 = Double Data Rate CMOS Output Mode
11 = Not Used

APPLICATIONS INFORMATION

REGISTER A4: DATA FORMAT REGISTER (ADDRESS 04h)

D7	D6	D5	D4	D3	D2	D1	D0
X	X	OUTTEST2	OUTTEST1	OUTTEST0	ABP	RAND	TWOSCOMP

Bit 7-6 Unused, Don't Care Bits.

Bits 5-3 **OUTTEST2:OUTTEST0** Digital Output Test Pattern Bits
 000 = Digital Output Test Patterns Off
 001 = All Digital Outputs = 0
 011 = All Digital Outputs = 1
 101 = Checkerboard Output Pattern. OF, D11-D0 Alternate Between 1 0101 1010 0101 and 0 1010 0101 1010
 111 = Alternating Output Pattern. OF, D11-D0 Alternate Between 0 0000 0000 0000 and 1 1111 1111 1111
 Note: Other Bit Combinations are not Used

Bit 2 **ABP** Alternate Bit Polarity Mode Control Bit
 0 = Alternate Bit Polarity Mode Off
 1 = Alternate Bit Polarity Mode On

Bit 1 **RAND** Data Output Randomizer Mode Control Bit
 0 = Data Output Randomizer Mode Off
 1 = Data Output Randomizer Mode On

Bit 0 **TWOSCOMP** Two's Complement Mode Control Bit
 0 = Offset Binary Data Format
 1 = Two's Complement Data Format
 Note: ABP = 1 forces the output format to be Offset Binary

GROUNDING AND BYPASSING

The LTC2258-12 requires a printed circuit board with a clean unbroken ground plane. A multilayer board with an internal ground plane is recommended. Layout for the printed circuit board should ensure that digital and analog signal lines are separated as much as possible. In particular, care should be taken not to run any digital track alongside an analog signal track or underneath the ADC.

High quality ceramic bypass capacitors should be used at the V_{DD} , OV_{DD} , V_{CM} , V_{REF} , REFH and REFL pins. Bypass capacitors must be located as close to the pins as possible. Of particular importance is the 0.1 μ F capacitor between REFH and REFL. This capacitor should be on the same side of the circuit board as the A/D, and as close to the device as possible (1.5mm or less). Size 0402 ceramic capacitors are recommended. The larger 2.2 μ F capacitor between REFH and REFL can be somewhat further away.

The V_{CM} capacitor should be located as close to the pin as possible. To make space for this the capacitor on V_{REF} can be further away or on the back of the PC board. The traces connecting the pins and bypass capacitors must be kept short and should be made as wide as possible.

The analog inputs, encode signals, and digital outputs should not be routed next to each other. Ground fill and grounded vias should be used as barriers to isolate these signals from each other.

HEAT TRANSFER

Most of the heat generated by the LTC2258-12 is transferred from the die through the bottom-side exposed pad and package leads onto the printed circuit board. For good electrical and thermal performance, the exposed pad must be soldered to a large grounded pad on the PC board.

TYPICAL APPLICATIONS

LTC2258 Schematic

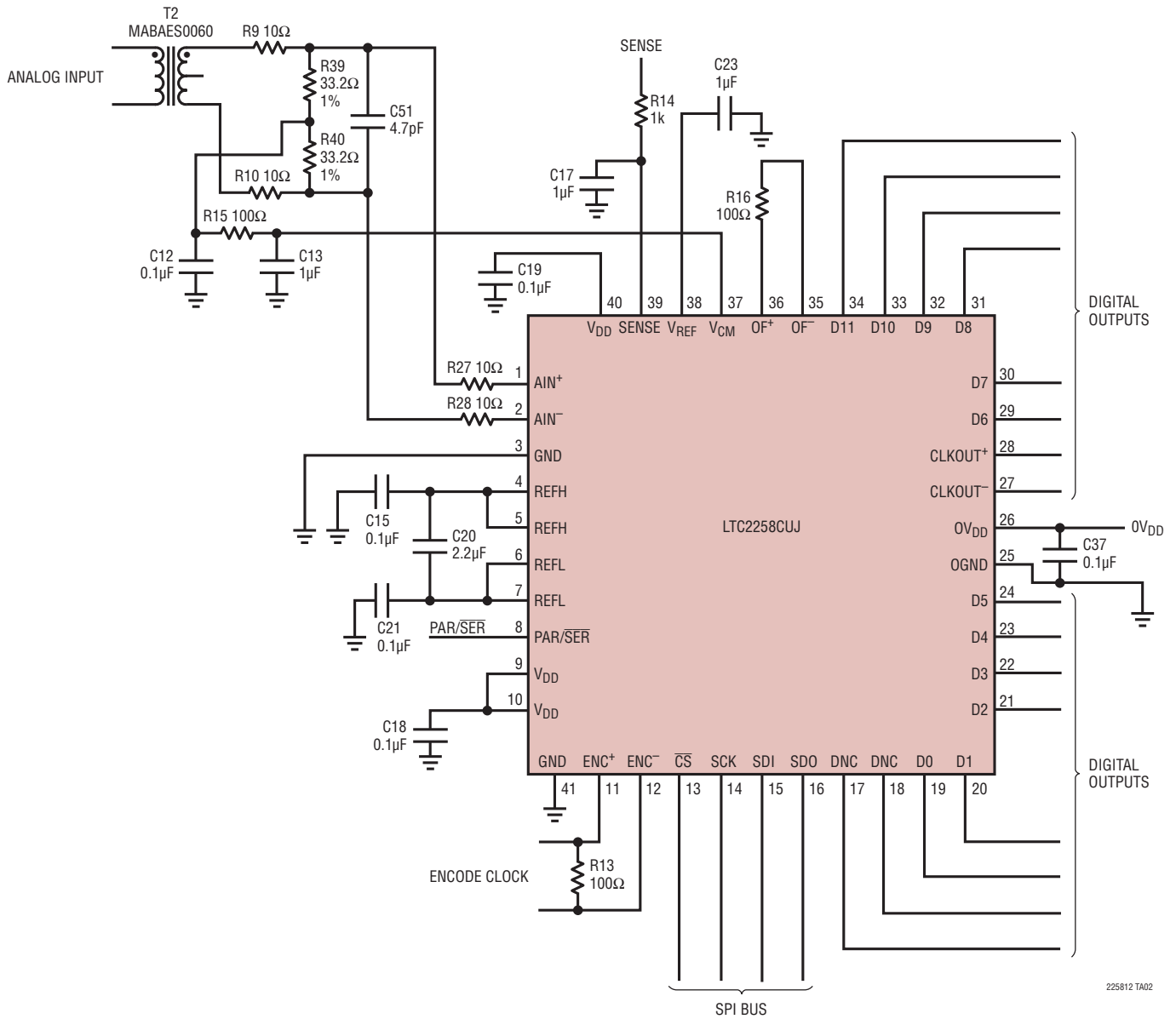

225812 TA02

TYPICAL APPLICATIONS

Silkscreen Top

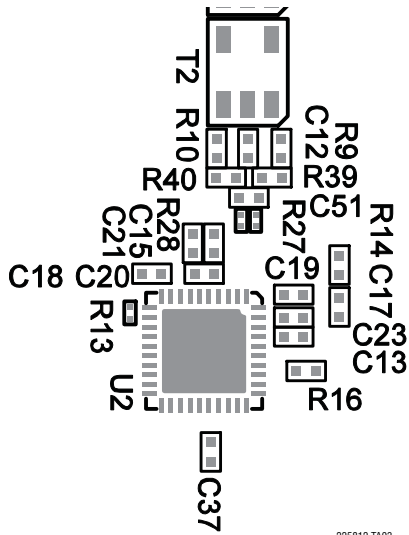

225812 TA03

Top Side

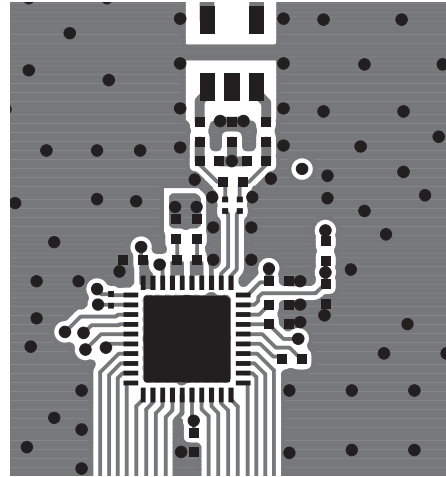

225812 TA04

Inner Layer 2 GND

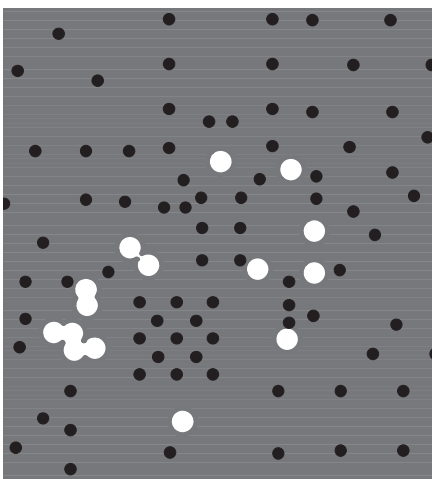

225812 TA05

Inner Layer 3

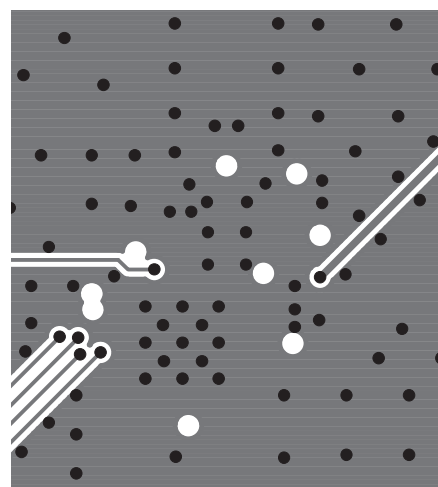

225812 TA06

TYPICAL APPLICATIONS

Inner Layer 4

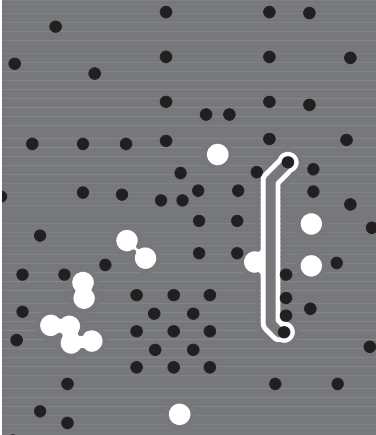

225812 TA07

Inner Layer 5 Power

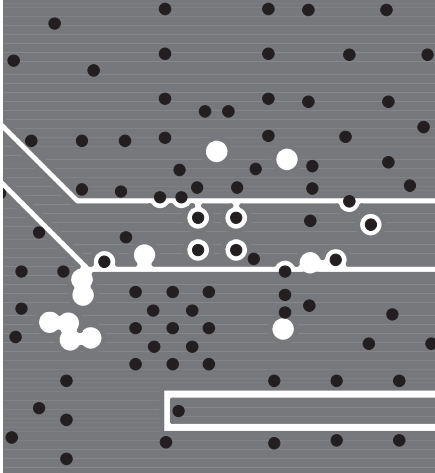

225812 TA08

Bottom Side

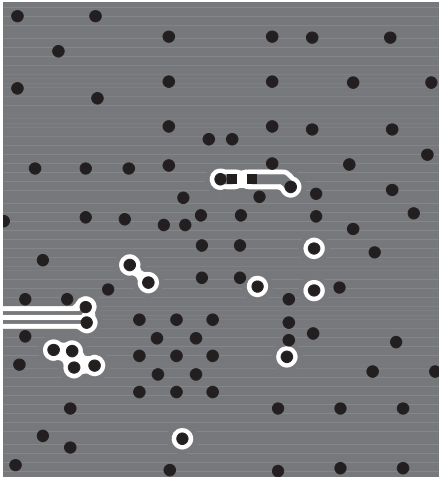

225812 TA09

PACKAGE DESCRIPTION

UJ Package
40-Lead Plastic QFN (6mm × 6mm)
(Reference LTC DWG # 05-08-1728 Rev 0)

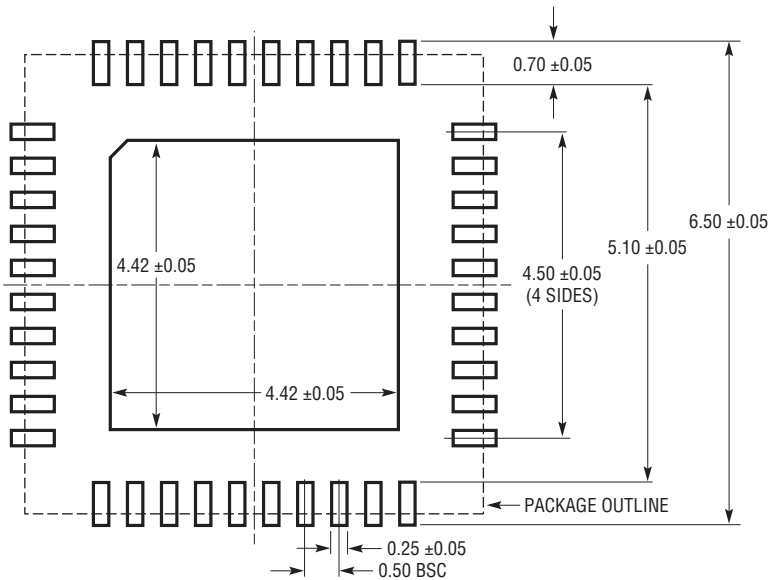

RECOMMENDED SOLDER PAD PITCH AND DIMENSIONS
APPLY SOLDER MASK TO AREAS THAT ARE NOT SOLDERED

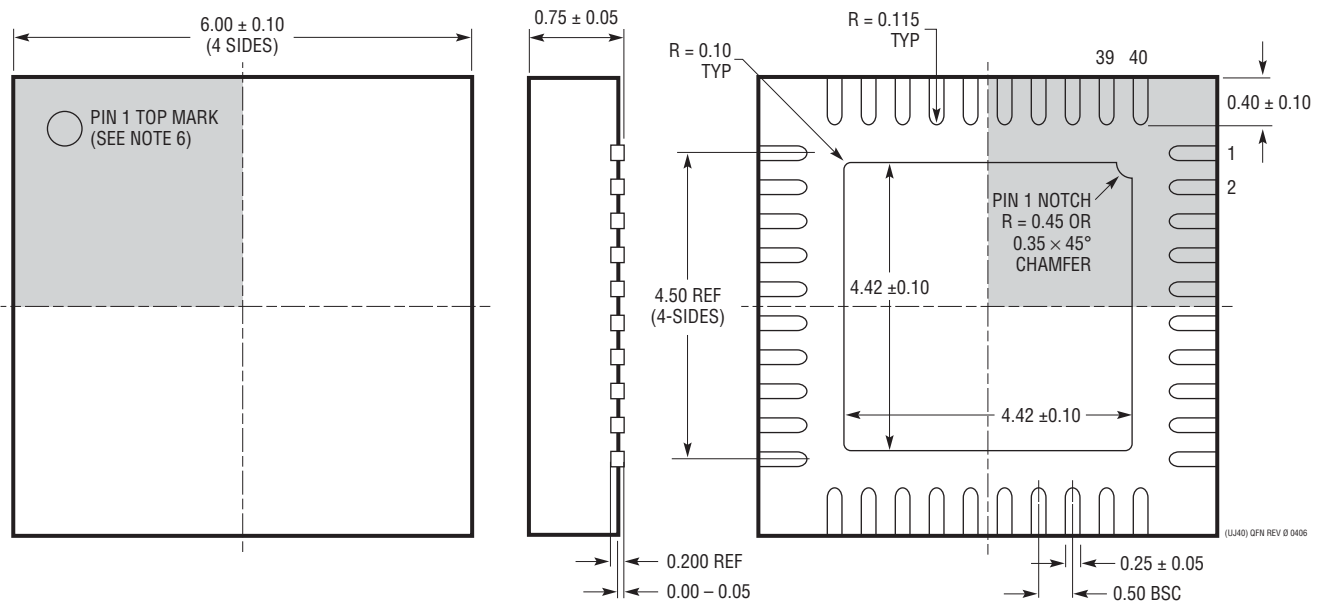

- NOTE:
1. DRAWING IS A JEDEC PACKAGE OUTLINE VARIATION OF (WJJD-2)
 2. DRAWING NOT TO SCALE
 3. ALL DIMENSIONS ARE IN MILLIMETERS
 4. DIMENSIONS OF EXPOSED PAD ON BOTTOM OF PACKAGE DO NOT INCLUDE MOLD FLASH. MOLD FLASH, IF PRESENT, SHALL NOT EXCEED 0.20mm ON ANY SIDE, IF PRESENT
 5. EXPOSED PAD SHALL BE SOLDER PLATED
 6. SHADED AREA IS ONLY A REFERENCE FOR PIN 1 LOCATION ON THE TOP AND BOTTOM OF PACKAGE

BOTTOM VIEW—EXPOSED PAD

LTC2258-12

LTC2257-12/LTC2256-12

RELATED PARTS

PART NUMBER	DESCRIPTION	COMMENTS
LTC1993-2	High Speed Differential Op Amp	800MHz BW, 70dBc Distortion at 70MHz, 6dB Gain
LTC1994	Low Noise, Low Distortion Fully Differential Input/Output Amplifier/Driver	Low Distortion: -94dBc at 1MHz
LTC2215	16-Bit, 65Msps, Low Noise ADC	700mW, 81.5dB SNR, 100dB SFDR, 64-Pin QFN
LTC2216	16-Bit, 80Msps, Low Noise ADC	970mW, 81.3dB SNR, 100dB SFDR, 64-Pin QFN
LTC2217	16-Bit, 105Msps, Low Noise ADC	1190mW, 81.2dB SNR, 100dB SFDR, 64-Pin QFN
LTC2202	16-Bit, 10Msps, 3.3V ADC, Lowest Noise	140mW, 81.6dB SNR, 100dB SFDR, 48-Pin QFN
LTC2203	16-Bit, 25Msps, 3.3V ADC, Lowest Noise	220mW, 81.6dB SNR, 100dB SFDR, 48-Pin QFN
LTC2204	16-Bit, 40Msps, 3.3V ADC	480mW, 79dB SNR, 100dB SFDR, 48-Pin QFN
LTC2205	16-Bit, 65Msps, 3.3V ADC	590mW, 79dB SNR, 100dB SFDR, 48-Pin QFN
LTC2206	16-Bit, 80Msps, 3.3V ADC	725mW, 77.9dB SNR, 100dB SFDR, 48-Pin QFN
LTC2207	16-Bit, 105Msps, 3.3V ADC	900mW, 77.9dB SNR, 100dB SFDR, 48-Pin QFN
LTC2208	16-Bit, 130Msps, 3.3V ADC, LVDS Outputs	1250mW, 77.7dB SNR, 100dB SFDR, 64-Pin QFN
LTC2209	16-Bit, 160Msps, 3.3V ADC, LVDS Outputs	1450mW, 77.1dB SNR, 100dB SFDR, 64-Pin QFN
LTC2220	12-Bit, 170Msps ADC	890mW, 67.5dB SNR, 9mm × 9mm QFN Package
LTC2220-1	12-Bit, 185Msps, 3.3V ADC, LVDS Outputs	910mW, 67.7dB SNR, 80dB SFDR, 64-Pin QFN
LTC2224	12-Bit, 135Msps, 3.3V ADC, High IF Sampling	630mW, 67.6dB SNR, 84dB SFDR, 48-Pin QFN
LTC2249	14-Bit, 80Msps ADC	230mW, 73dB SNR, 5mm × 5mm QFN Package
LTC2250	10-Bit, 105Msps ADC	320mW, 61.6dB SNR, 5mm × 5mm QFN Package
LTC2251	10-Bit, 125Msps ADC	395mW, 61.6dB SNR, 5mm × 5mm QFN Package
LTC2252	12-Bit, 105Msps ADC	320mW, 70.2dB SNR, 5mm × 5mm QFN Package
LTC2253	12-Bit, 125Msps ADC	395mW, 70.2dB SNR, 5mm × 5mm QFN Package
LTC2254	14-Bit, 105Msps ADC	320mW, 72.5dB SNR, 5mm × 5mm QFN Package
LTC2255	14-Bit, 125Msps, 3V ADC, Lowest Power	395mW, 72.5dB SNR, 88dB SFDR, 32-Pin QFN
LTC2259-14/ LTC2260-14/ LTC2261-14	14-Bit, 80/105/125Msps 1.8V ADCs, Ultra-Low Power	89mW/106mW/127mW, 73.4dB SNR, 85dB SFDR DDR LVDS/DDR CMOS/CMOS Outputs, 6mm × 6mm QFN Package
LTC2284	14-Bit, Dual, 105Msps, 3V ADC, Low Crosstalk	540mW, 72.4dB SNR, 88dB SFDR, 64-Pin QFN
LTC2299	Dual 14-Bit, 80Msps ADC	230mW, 71.6dB SNR, 5mm × 5mm QFN Package
LTC5517	40MHz to 900MHz Direct Conversion Quadrature Demodulator	High IIP3: 21dBm at 800MHz, Integrated LO Quadrature Generator
LTC5527	400MHz to 3.7GHz High Linearity Downconverting Mixer	24.5dBm IIP3 at 900MHz, 23.5dBm IIP3 at 3.5GHz, NF = 12.5dB, 50Ω Single-Ended RF and LO Ports
LTC5557	400MHz to 3.8GHz High Linearity Downconverting Mixer	23.7dBm IIP3 at 2.6GHz, 23.5dBm IIP3 at 3.5GHz, NF = 13.2dB, 3.3V Supply Operation, Integrated Transformer
LTC5575	800MHz to 2.7GHz Direct Conversion Quadrature Demodulator	High IIP3: 28dBm at 900MHz, Integrated LO Quadrature Generator Integrated RF and LO Transformer
LTC6400-20	1.8GHz Low Noise, Low Distortion Differential ADC Driver for 300MHz IF	Fixed Gain 10V/V, 2.1nV/√Hz Total Input Noise, 3mm × 3mm QFN-16 Package
LTC6604-2.5/ LTC6604 -5/ LTC6604-10/ LTC6604-15	Dual Matched 2.5MHz, 5MHz, 10MHz, 15MHz Filter with ADC Driver	Dual Matched 4th Order LP Filters with Differential Drivers. Low Noise, Low Distortion Amplifiers