

FEATURES

- Withstands Transient Voltages Up to 200V/-200V
- Requires No Precision External Components
- Independently Monitors Two -48V Supplies for
 - Undervoltage Faults: $-38.5V \pm 1V_{MAX}$
 - Overvoltage Faults: $-70V \pm 1.5V_{MAX}$
- Accurately Detects Undervoltage Fault Recovery: $-43V \pm 0.5V_{MAX}$
- Monitors Two External Fuses
- Operates from -10V to -80V
- Tolerates DC Faults to -100V
- Tolerates Accidental Supply Reversal to 100V
- Small Footprint: 8-Lead MSOP Package
- Specified from -40°C to 85°C

APPLICATIONS

- Telecom Backplanes or Switch Cards
- Networking Backplanes or Switch Cards
- High Voltage Fuse Monitoring

DESCRIPTION

The LTC[®]1921 monitors two independent -48V supplies, including their fuses, and drives up to three optoisolators to indicate status, in accordance with standard backplane specifications. Requiring only three noncritical resistors and optoisolators, the LTC1921 replaces multiple voltage comparators, a voltage reference and several precision resistors.

The monitor features dual supply overvoltage and undervoltage detection circuits. The preset trip thresholds include overvoltage, undervoltage and undervoltage recovery that are guaranteed over temperature and meet or exceed common backplane specifications. Additional built-in circuitry detects the condition of supply fuses. Overvoltage and undervoltage detectors ignore fast supply transients, eliminating false detection. The LTC1921 operates from -10V to -80V with a typical power dissipation of less than 10mW.

The LTC1921 is available in 8-pin MSOP and SOIC packages.

LT, LTC and LT are registered trademarks of Linear Technology Corporation.

TYPICAL APPLICATION

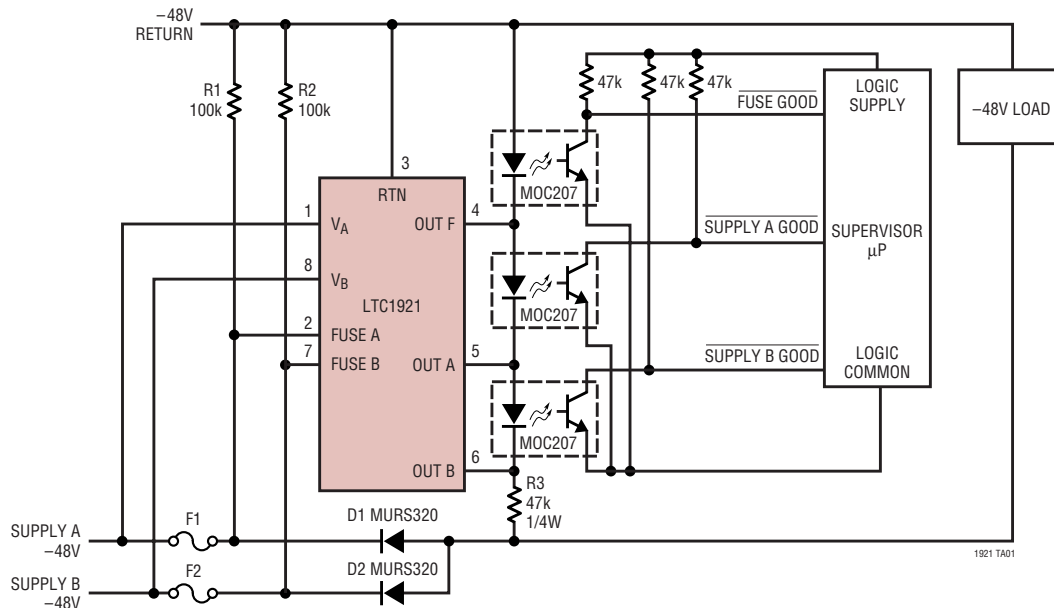

1921 TA01

LTC1921

ABSOLUTE MAXIMUM RATINGS

(Note 1) All voltages referred to RTN

Supply Voltage (V_A , V_B , FUSE A, FUSE B)	100V to -100V
Transient Voltage (V_A , V_B , FUSE A, FUSE B) (Note 2)	0V to 200V
Transient Voltage (V_A , V_B , FUSE A, FUSE B) (Note 2)	0V to -200V
OUT A, OUT B, OUT F Pins	0.3V to -8V

Maximum Junction Temperature	150°C
Operating Temperature Range (Note 3)	LTC1921C/LTC1921I -40°C to 85°C
Specified Temperature Range (Note 4)	LTC1921C/LTC1921I -40°C to 85°C
Storage Temperature Range	-65°C to 150°C
Lead Temperature (Soldering, 10 sec)	300°C

PACKAGE/ORDER INFORMATION

<p>MS8 PACKAGE 8-LEAD PLASTIC MSOP $T_{JMAX} = 150^{\circ}\text{C}$, $\theta_{JA} = 300^{\circ}\text{C/W}$</p>	ORDER PART NUMBER	<p>S8 PACKAGE 8-LEAD PLASTIC SO $T_{JMAX} = 150^{\circ}\text{C}$, $\theta_{JA} = 190^{\circ}\text{C/W}$</p>	ORDER PART NUMBER
	LTC1921CMS8 LTC1921IMS8		LTC1921CS8 LTC1921IS8
	MS8 PART MARKING		S8 PART MARKING
	LTZV LTZU		1921 1921I

Consult LTC Marketing for parts specified with wider operating temperature ranges.

ELECTRICAL CHARACTERISTICS

The ● denotes specifications which apply over the full operating temperature range, otherwise specifications are at $T_A = 25^{\circ}\text{C}$. (Note 5) $\text{RTN} = 0\text{V}$, $V_A = -48\text{V}$, $V_B = -48\text{V}$, FUSE A = -48V, FUSE B = -48V, unless otherwise noted.

PARAMETER	CONDITIONS	MIN	TYP	MAX	UNITS
Power Supply					
Supply Voltage Range ($\text{RTN} - V_A$, $\text{RTN} - V_B$)		● 10		80	V
Supply Current ($I_A + I_B$)			-160	-250 -300	μA μA
Supply Monitor					
Undervoltage Threshold		● -39.5		-37.5	V
Undervoltage Recovery Threshold		● -43.5		-42.5	V
Overshoot Threshold		● -71.5		-68.5	V
Overshoot Threshold Hysteresis		● 1		1.6	V
Fuse Monitor					
Input Resistance, FUSE A, FUSE B			11		$\text{M}\Omega$
Fuse Comparison Threshold $ V_{\text{FUSEA}} - V_A $, $ V_{\text{FUSEB}} - V_B $	LTC1921C	● 0.9		4.5	V
	LTC1921I	● 0.5		4.5	V
Output					
Propagation Delay	$C_{\text{OUT}} = 100\text{pF}$, Overdrive = 1V		220		μs
Output Switch Resistance, OUT F, OUT A, OUT B	$V_A = V_B = -35\text{V}$, $V_{\text{FUSEA}} = V_{\text{FUSEB}} = 0\text{V}$ $I_{\text{OUT}} = 10\text{mA}$	●	25	50	Ω Ω

1921f

ELECTRICAL CHARACTERISTICS The ● denotes specifications which apply over the full operating temperature range, otherwise specifications are at $T_A = 25^\circ\text{C}$. (Note 5) $\text{RTN} = 0\text{V}$, $V_A = -48\text{V}$, $V_B = -48\text{V}$, FUSE A = -48V, FUSE B = -48V, unless otherwise noted.

PARAMETER	CONDITIONS	MIN	TYP	MAX	UNITS
Output Switch Off Leakage			500		pA
Output Switch Resistance in Undervoltage Lockout, OUT F, OUT A, OUT B	$V_A = V_B = -10\text{V}$, $I_{\text{OUT}} = 10\text{mA}$	●		60	Ω
	$V_A = -10\text{V}$, $V_B = 0\text{V}$, $I_{\text{OUT}} = 10\text{mA}$	●		80	Ω
	$V_A = 0\text{V}$, $V_B = -10\text{V}$, $I_{\text{OUT}} = 10\text{mA}$	●		80	Ω

Note 1: Absolute Maximum Ratings are those values beyond which the life of a device may be impaired.

Note 2: Transient voltage for less than 10 μs . This parameter is not 100% tested. Voltage should not exceed 200V between any two pins.

Note 3: The LTC1921C and LTC1921I are guaranteed functional over the operating temperature range of -40°C to 85°C .

Note 4: The LTC1921C is guaranteed to meet specified performance from 0°C to 70°C . The LTC1921C is designed, characterized and expected to meet specified performance from -40°C to 85°C but is not tested or QA sampled at these temperatures. The LTC1921I is guaranteed to meet specified performance from -40 to 85°C .

Note 5: All currents into device pins are positive; all currents out of device pins are negative. All voltages are referenced to RTN unless otherwise specified.

TYPICAL PERFORMANCE CHARACTERISTICS

Supply Current vs Supply Voltage



1921 G01

Supply Current vs Temperature

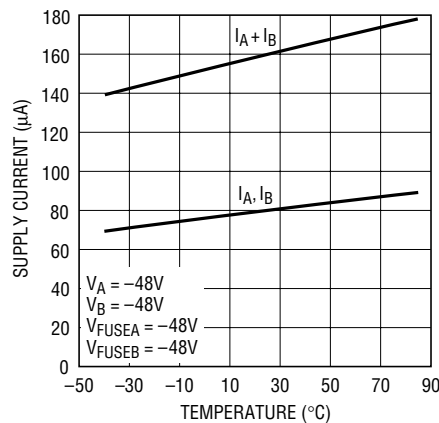

1921 G02

Undervoltage Threshold vs Temperature



1921 G04

Undervoltage Recovery Threshold vs Temperature

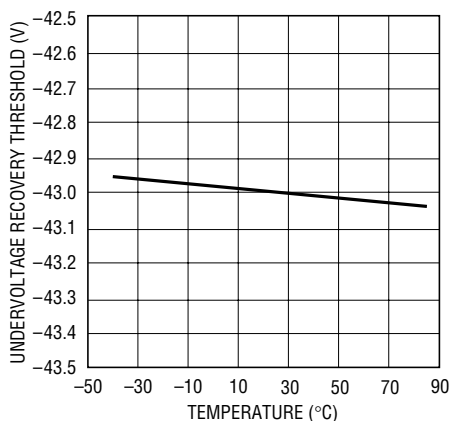

1921 G04

Overvoltage Threshold vs Temperature

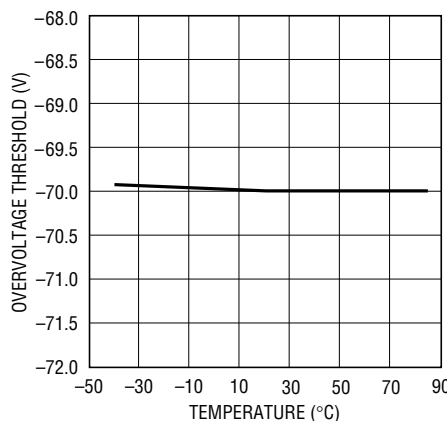

1921 G05

Overvoltage Hysteresis vs Temperature

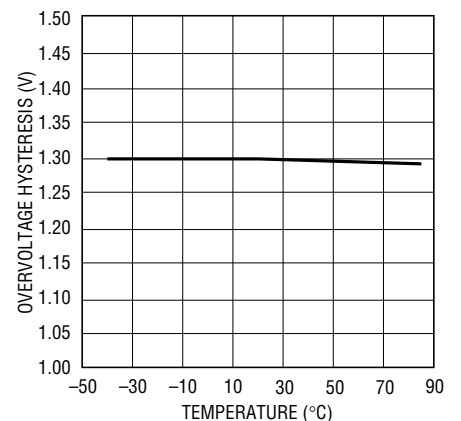

1921 G06

1921F

TYPICAL PERFORMANCE CHARACTERISTICS

Fuse Window Positive Threshold vs Temperature

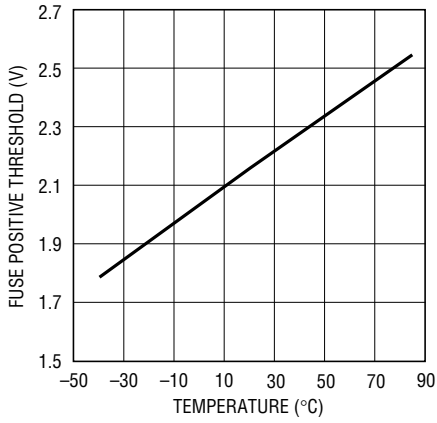

1921 G07

Fuse Window Negative Threshold vs Temperature

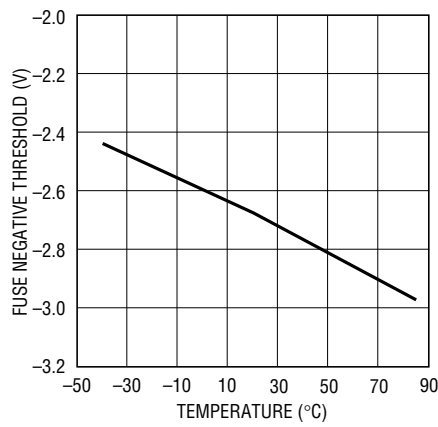

1921 G08

Output $R_{DS(ON)}$ vs Temperature

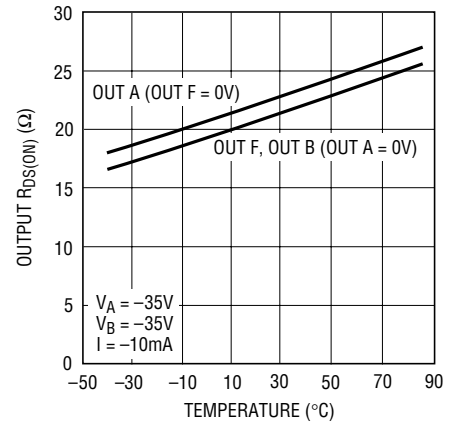

1921 G09

Undervoltage Response Time

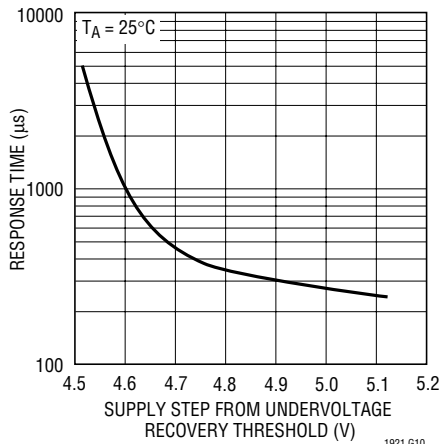

1921 G10

Overvoltage Response Time

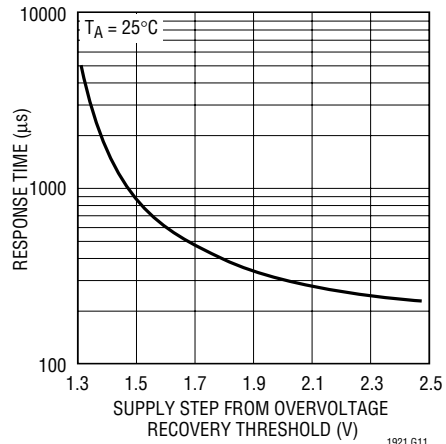

1921 G11

PIN FUNCTIONS

V_A (Pin 1): Supply to be Monitored. The voltage at this pin is compared to the valid supply voltage window and the result is output at OUT A (Pin 5). Supply current is drawn from V_A as well as from V_B (Pin 8).

FUSE A (Pin 2): This pin monitors the state of a fuse by comparing the voltage at this pin to the voltage at V_A (Pin 1). The result is output at OUT F (Pin 4).

RTN (Pin 3): Supply Return Reference. This pin must be at an equal or higher potential than the other pins and should be wired to the –48V return.

OUT F (Pin 4): This pin indicates the state of the external fuses by ORing the comparisons made to the FUSE A and FUSE B pins. If $V_{FUSEA} \cong V_A$ (V_{FUSEA} is within the specified window around V_A) and $V_{FUSEB} \cong V_B$, then OUT F will exhibit a high internal impedance to the RTN pin. If $V_{FUSEA} \neq V_A$ or $V_{FUSEB} \neq V_B$, then OUT F is shorted internally to the RTN pin and can shunt enough current to turn off an optoisolator or LED wired between these pins. OUT F should be clamped externally so that it cannot be driven more than 8V below RTN. This is done automatically by the optoisolator or LED diodes shown in the application circuits.

OUT A (Pin 5): Indicates the state of V_A. If V_A is within the specified voltage window (neither undervoltage nor overvoltage), OUT A will exhibit a high internal impedance to the

OUT F pin. If V_A is outside the specified overvoltage or undervoltage limits, then OUT A is shorted internally to the OUT F pin and can shunt enough current to turn off an optoisolator or LED wired between these pins. OUT A should be clamped externally so that it cannot be driven more than 8V below RTN. This is done automatically by the optoisolator or LED diodes shown in the application circuits.

OUT B (Pin 6): Indicates the state of V_B. If V_B is within the specified voltage window (neither undervoltage nor overvoltage), OUT B will exhibit a high internal impedance to the OUT A pin. If V_B is outside the specified overvoltage or undervoltage limits, then OUT B is shorted internally to the OUT A pin and can shunt enough current to turn off an optoisolator or LED wired between these pins. OUT B should be clamped externally so that it cannot be driven more than 8V below RTN. This is done automatically by the optoisolator or LED diodes shown in the application circuits.

FUSE B (Pin 7): This pin monitors the state of a fuse by comparing the voltage at this pin to the voltage at V_B (Pin 8). The result is output at OUT F (Pin 4).

V_B (Pin 8): Supply to be Monitored. The voltage at this pin is compared to the valid supply voltage window and the result is output at OUT B (Pin 6). Supply current is drawn from V_B as well as from V_A (Pin 1).

BLOCK DIAGRAM

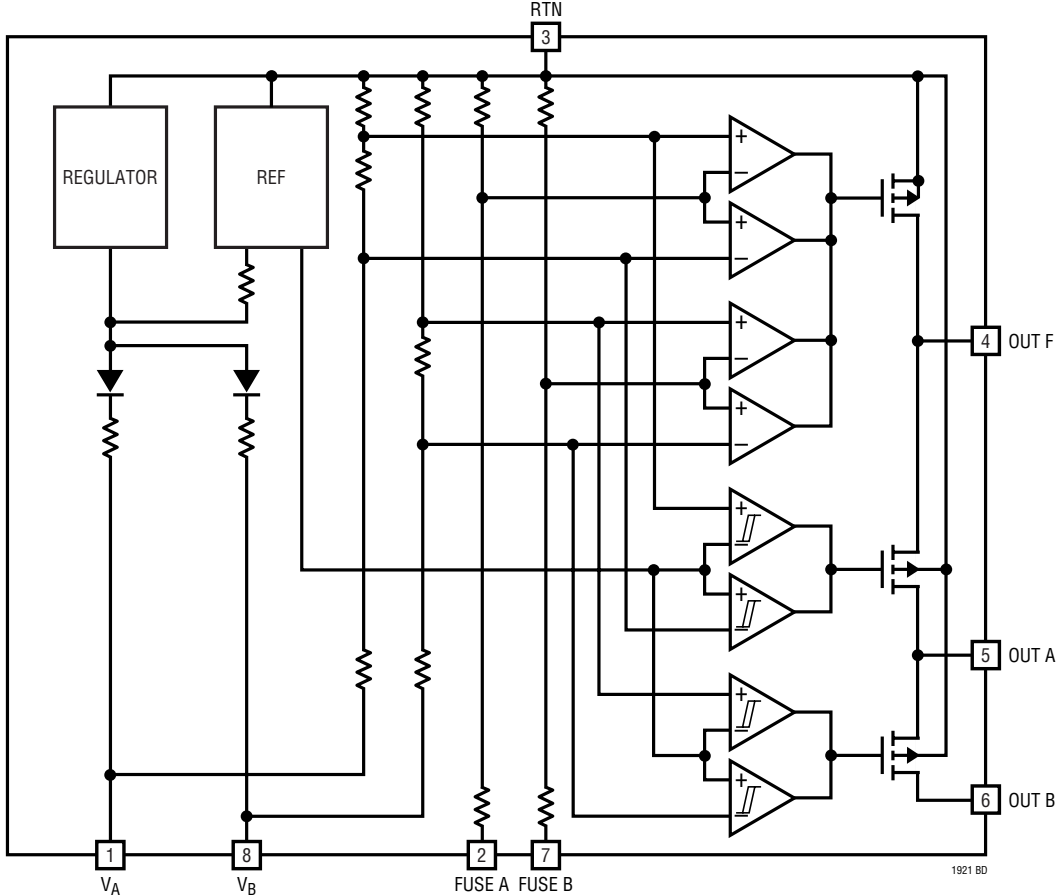

APPLICATIONS INFORMATION

Supply Monitoring

The LTC1921 is designed to monitor dual -48V power supplies. This is accomplished with precision window comparators and an accurate bandgap reference, as well as internal level shifting circuitry. The comparators are preset to standard voltage thresholds in order to accurately verify the status of each supply. These comparators also include precision hysteresis which allows accurate determination of voltage recovery. Status of the two supplies are indicated by the OUT A and OUT B pins.

The supply window comparison works in a straightforward way (Figure 1). As long as each supply magnitude remains in the valid supply window (38.5V to 70V), the outputs will indicate a valid supply condition by exhibiting a high internal impedance. If a supply magnitude falls below the undervoltage threshold (38.5V), then its respective output will short internally (OUT A to OUT F or OUT B to OUT A) until that supply reaches the undervoltage recovery threshold, which is preset to -43V . At this time, the output will return to a high impedance state. If a supply magnitude rises above the overvoltage threshold (70V), then its respective output will short internally, just as with an undervoltage condition. The output will return to its nominal state when the supply overcomes the overvoltage hysteresis.

Monitoring for each supply, V_A and V_B , is independent of the condition of the other supply. The LTC1921 can be powered equally from either V_A , V_B or both supplies. This allows the LTC1921 to provide correct information at its outputs as long as at least one supply is functional, whether or not the fuses are intact (see Figure 2).

Undervoltage Lockout

If both supplies are active and their magnitude falls below 13V , or if only one supply is active and its magnitude falls below 19V , the LTC1921 will lock all outputs into a fault condition by closing all three output switches. This state will be held until one supply magnitude is driven above 19V or both are driven above 13V .

Fuse Monitoring

In addition to monitoring two supplies, the LTC1921 can monitor the condition of two supply fuses via the FUSE A (Pin 2) and FUSE B (Pin 7) inputs. Fuse monitoring is accomplished by comparing the potential at FUSE A to the potential at supply V_A and comparing the potential at FUSE B to the potential at supply V_B . If V_{FUSEA} is within the specified voltage window around V_A and V_{FUSEB} is within the specified voltage window around V_B , the OUT F pin will indicate that the fuses are intact by exhibiting a high



Figure 1. Supply Comparison

APPLICATIONS INFORMATION

internal impedance to the return (RTN) pin. The application must be designed so that an open fuse condition will force the fuse input (FUSE A or FUSE B) to be outside the specified window around the supply pins, such as with a weak pull-up resistor to RTN, so that the LTC1921 can properly indicate a fault at OUT F. If supply diodes that exhibit high reverse leakage, such as Schottky diodes, are used, then the values of the pull-up resistors must be reduced accordingly.

The FUSE A and FUSE B pins may also be used in conjunction with V_A and V_B for simple window comparison, provided that one of the circuit nodes to be compared can provide the small amount of supply current required to bias the IC. The LTC1921 is ideally suited for comparison functions in a circuit where only high supply voltages are available.

Output Pins

The output pins in the LTC1921 are designed to shunt external optoisolator diodes or LEDs during a supply or fuse fault condition. Up to three diodes may be used in

series, one for each output. In this configuration (Figure 2), a diode connected between OUT F and RTN will indicate the condition of both fuses. A diode connected between OUT A and OUT F will indicate the condition of supply A (V_A) and a diode connected between OUT B and OUT A will indicate the condition of supply B (V_B). A resistor connected from OUT B to the negative supply is required to bias the diodes. The LTC1921 is designed to allow the current from this resistor to flow through the diodes during normal supply conditions and intact fuses, and will shunt this current away from the proper diodes during a fault condition. These diodes will further clamp the output pin potentials to RTN in order to keep the outputs within rated voltages. If LEDs are used instead of optoisolators, they should be green since they will be lit when the supplies are within the proper voltage range.

The LTC1921 may be connected in such a way as to OR various outputs to allow the use of fewer optocouplers or LEDs (Figures 3a and 3b). One and two diode circuits are shown.

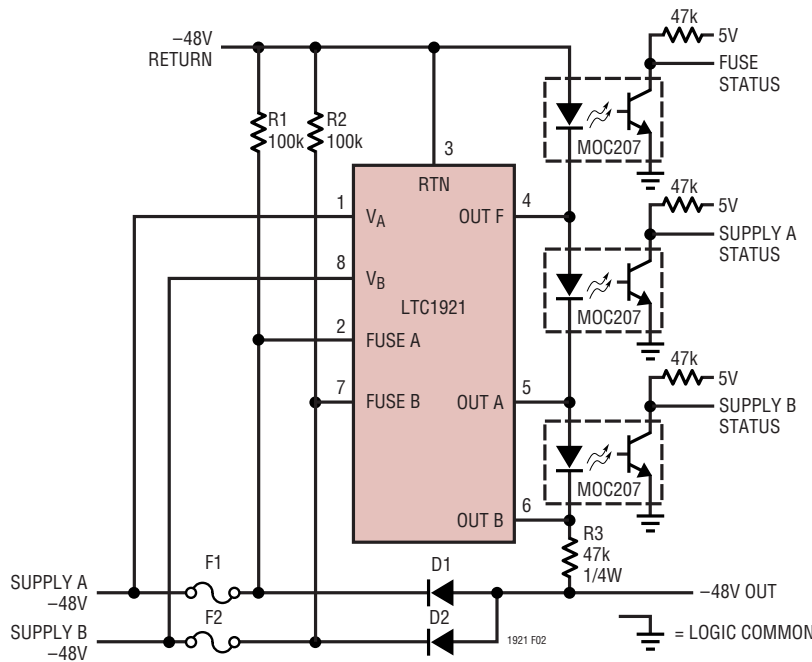

V_A	V_B	SUPPLY A STATUS	SUPPLY B STATUS
OK	OK	0	0
OK	UV OR OV	0	1
UV OR OV	OK	1	0
UV OR OV	UV OR OV	1	1

OK: WITHIN SPECIFICATION
 OV: OVERVOLTAGE
 UV: UNDERVOLTAGE

$V_{FUSE A}$	$V_{FUSE B}$	FUSE STATUS
$= V_A$	$= V_B$	0
$= V_A$	$\neq V_B$	1
$\neq V_A$	$= V_B$	1
$\neq V_A$	$\neq V_B$	1*

0: LED/PHOTODIODE ON
 1: LED/PHOTODIODE OFF
 *IF BOTH FUSES (F1 AND F2) ARE OPEN,
 ALL STATUS OUTPUTS WILL BE HIGH
 SINCE R3 WILL NOT BE POWERED

Figure 2.

APPLICATIONS INFORMATION



V _A	V _B	SUPPLY STATUS
OK	OK	0
OK	UV OR OV	1
UV OR OV	OK	1
UV OR OV	UV OR OV	1

OK: WITHIN SPECIFICATION
 OV: OVERVOLTAGE
 UV: UNDERVOLTAGE

V _{FUSE A}	V _{FUSE B}	FUSE STATUS
= V _A	= V _B	0
= V _A	≠ V _B	1
≠ V _A	= V _B	1
≠ V _A	≠ V _B	1*

0: LED/PHOTODIODE ON
 1: LED/PHOTODIODE OFF
 *IF BOTH FUSES (F1 AND F2) ARE OPEN,
 ALL STATUS OUTPUTS WILL BE HIGH
 SINCE R3 WILL NOT BE POWERED

Figure 3a. Combined Supply Status



V _{FUSE A}	V _{FUSE B}	V _A	V _B	STATUS
= V _A	= V _B	OK	OK	0
ALL OTHER CONDITIONS				1

OK: WITHIN SPECIFICATION
 0: LED/PHOTODIODE ON
 1: LED/PHOTODIODE OFF

Figure 3b. All Outputs Combined

TYPICAL APPLICATIONS

Complete -48V Telecom Supply Monitor and Hot Swap™ Controller

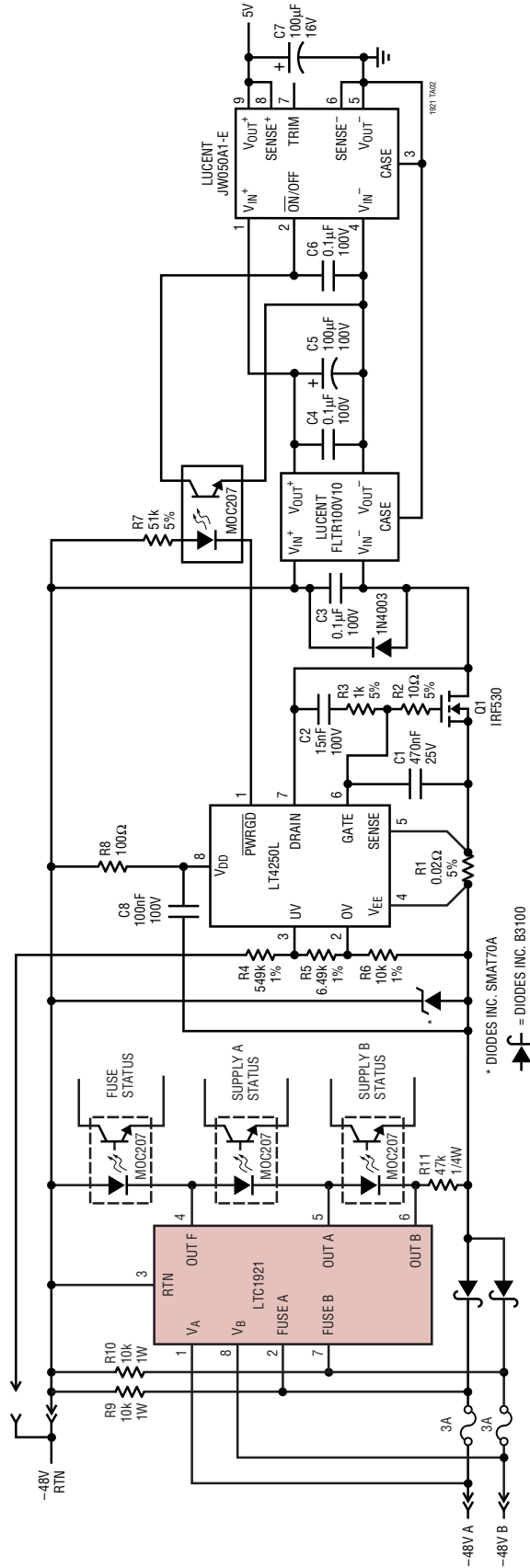

* DIODES INC. SMAT70A
 † DIODES INC. BS100

Hot Swap is a trademark of Linear Technology Corporation

PACKAGE DESCRIPTION

MS8 Package 8-Lead Plastic MSOP (Reference LTC DWG # 05-08-1660)

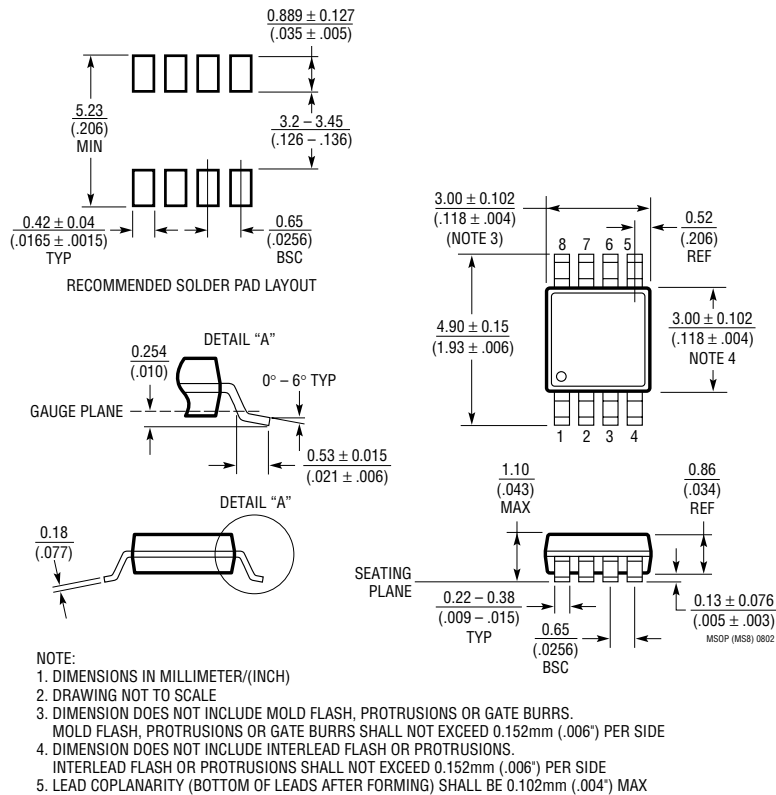

S8 Package 8-Lead Plastic Small Outline (Narrow .150 Inch) (Reference LTC DWG # 05-08-1610)

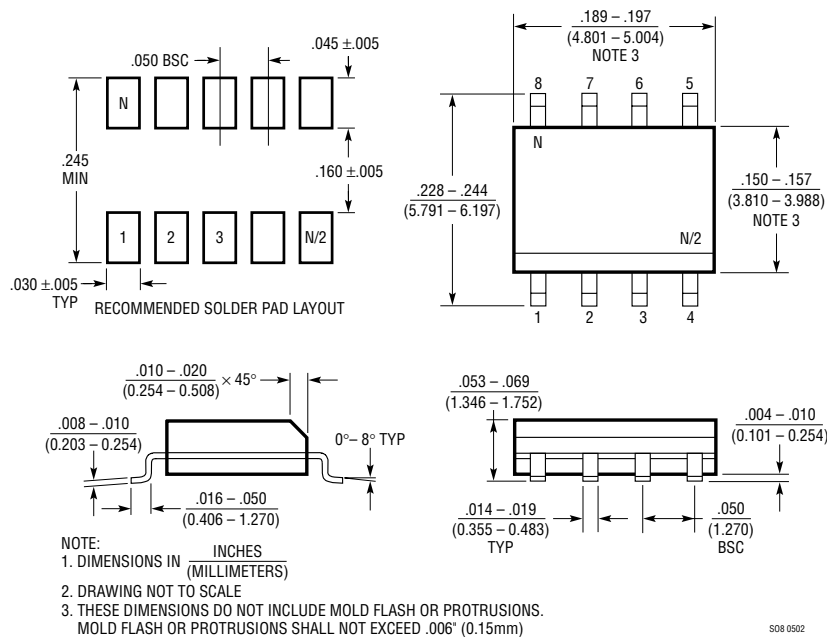

TYPICAL APPLICATIONS

Single 48V Supply Monitor



Single -48V Supply Monitor

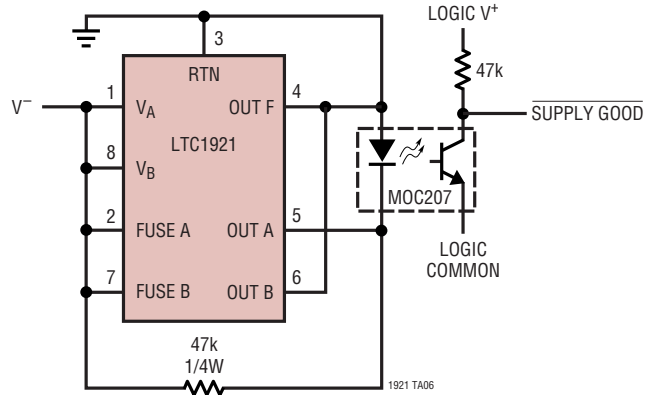

Voltage and Fuse Monitor with LED Outputs

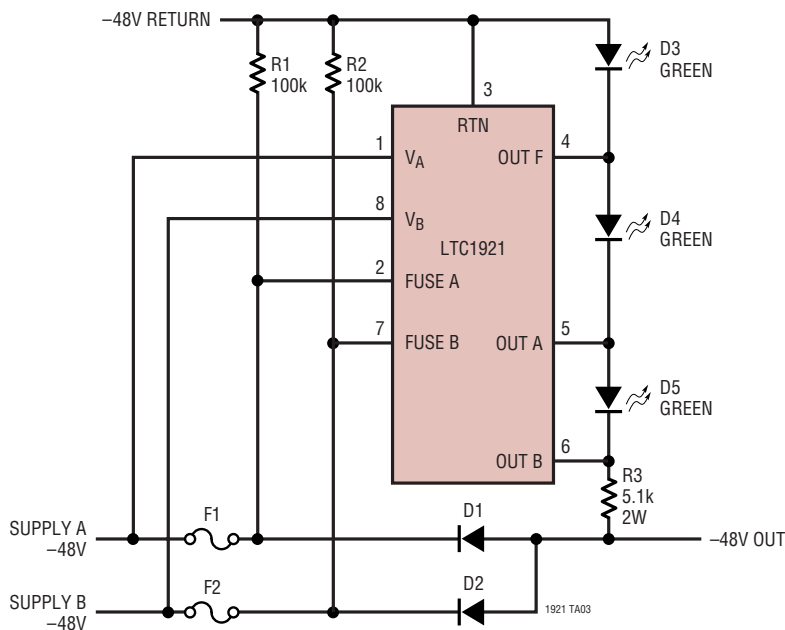

RELATED PARTS

PART NUMBER	DESCRIPTION	COMMENTS
LT4250	-48V Hot Swap Controller in SO-8 Package	Active Current Limiting, Supplies from -20V to -80V
LTC4251	-48V Hot Swap Controller in SOT-23 Package	Fast Active Current Limiting, Supplies from -15V (Floating)
LTC4252	-48V Hot Swap Controller in MSOP Package	Fast Active Current Limiting, Floating Supply, PWRGD Output
LTC4253	-48V Hot Swap Controller with Sequencer	Similar to LTC4252, Sequences Three DC/DC Converters