

FEATURES

- Improves SMBus Rise Time Transition
- Ensures Data Integrity with Multiple Devices on the SMBus
- Improves Low State Noise Margin
- Auto Detect Low Power Standby Mode
- Wide Supply Voltage Range: 2.7V to 6V
- Tiny 5-Pin SOT-23 Package

APPLICATIONS

- Notebook and Palmtop Computers
- Portable Instruments
- Battery Chargers
- Industrial Control Application
- TV/Video Products
- ACPI SMBus Interface

DESCRIPTION

The LTC[®]1694 is a dual SMBus active pull-up designed to enhance data transmission speed and reliability under all specified SMBus loading conditions. The LTC1694 is also compatible with the Philips I²C[™] Bus.

The LTC1694 allows multiple device connections or a longer, more capacitive interconnect, without compromising slew rates or bus performance, by using two bilevel hysteretic current source pull-ups.

During positive bus transitions, the LTC1694 current sources provide 2.2mA to quickly slew the SMBus line. During negative transitions or steady DC levels, the current sources decrease to 275 μ A to improve negative slew rate and improve low state noise margins. An auto detect standby mode reduces supply current if both SCL and SDA are high.

The LTC1694 is available in a 5-pin SOT-23 package, requiring virtually the same space as two surface mount resistors.

 LTC and LT are registered trademarks of Linear Technology Corporation. I²C is a trademark of Philips Electronics N.V.

TYPICAL APPLICATION

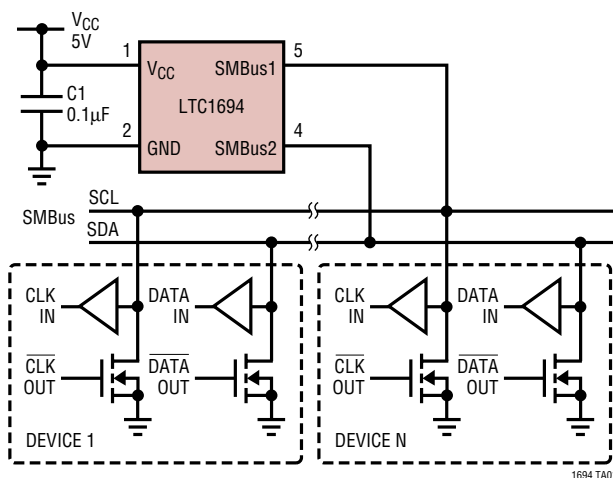

LTC1694: Patent Pending

Comparison of SMBus Waveforms for the LTC1694 vs Resistor Pull-Up

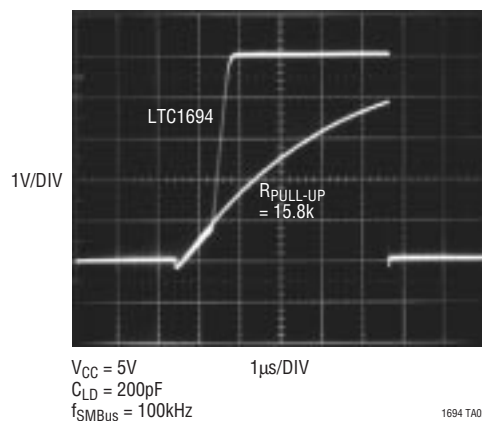

ABSOLUTE MAXIMUM RATINGS

(Note 1)

Supply Voltage (V_{CC})	7V
SMBus1, SMBus2 Inputs	-0.3V to ($V_{CC} + 0.3V$)
Operating Ambient Temperature Range	0°C to 70°C
Junction Temperature	125°C
Storage Temperature Range	-65°C to 150°C
Lead Temperature (Soldering, 10 sec.)	300°C

PACKAGE/ORDER INFORMATION

	ORDER PART NUMBER
	LTC1694CS5
	S5 PART MARKING
	LTEE

Consult factory for Industrial and Military grade parts.

ELECTRICAL CHARACTERISTICS

The ● denotes specifications that apply over the full operating temperature range, otherwise specifications are at $T_A = 25^\circ\text{C}$. $V_{CC} = 2.7V$ to $6V$ unless otherwise noted.

SYMBOL	PARAMETER	CONDITIONS	MIN	TYP	MAX	UNITS
V_{CC}	Supply Voltage Range		2.7		6	V
I_{CC}	Supply Current	SMBus1 = SMBus2 = Open	● 20	60	100	μA
$I_{PULL-UP}$	Pull-Up Current	SMBus1 = SMBus2 = 0V	● 125	275	350	μA
	Boosted Pull-Up Current	Positive Transition on SMBus (Figure 1) Slew Rate = $0.5V/\mu\text{s}$, SMBus > V_{THRES}	● 1.0	2.2		mA
V_{THRES}	Input Threshold Voltage	Slew Rate = $0.5V/\mu\text{s}$ (Figure 1)	● 0.4	0.65	0.9	V
SR_{THRES}	Slew Rate Detector Threshold	SMBus > V_{THRES}	●	0.2	0.5	$V/\mu\text{s}$
t_r	SMBus Rise Time	Bus Capacitance = 200pF (Note 2)	●	0.32	1.0	μs
	Standard Mode I ² C Bus Rise Time	Bus Capacitance = 400pF (Note 3)	●	0.30	1.0	μs
f_{MAX}	SMBus Maximum Operating Frequency	(Note 4)	●		100	kHz

Note 1: Absolute Maximum Ratings are those values beyond which the life of a device may be impaired.

Note 2: The rise time of an SMBus line is calculated from ($V_{IL(MAX)} - 0.15V$) to ($V_{IH(MIN)} + 0.15V$) or $0.65V$ to $2.25V$. This parameter is guaranteed by design and not tested. With a minimum pull-up current of $125\mu\text{A}$, a minimum boosted pull-up current of 1mA and a maximum input threshold voltage of $0.9V$:

$$\text{Rise Time} = [(0.9V - 0.65V)/125\mu\text{A} + (2.25V - 0.9V)/1\text{mA}] \cdot 200\text{pF} = 0.67\mu\text{s}$$

Note 3: The rise time of an I²C bus line is calculated from $V_{IL(MAX)}$ to $V_{IH(MIN)}$ or $1.5V$ to $3V$ (with $V_{CC} = 5V$). This parameter is guaranteed by design and not tested. With a minimum boosted pull-up current of 1mA :

$$\text{Rise Time} = (3V - 1.5V) \cdot 400\text{pF}/1\text{mA} = 0.6\mu\text{s}$$

Note 4: This parameter is guaranteed by design and not tested.

TYPICAL PERFORMANCE CHARACTERISTICS

Pull-Up Current at SMBus = 0V

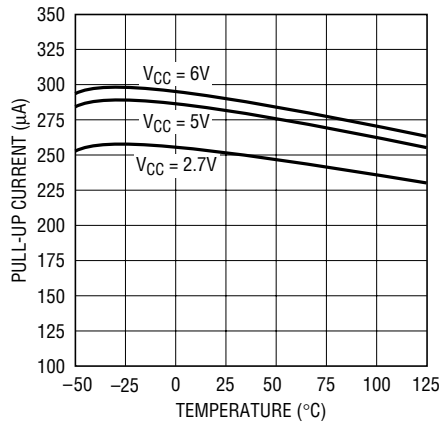

1694 G01

Boosted Pull-Up Current

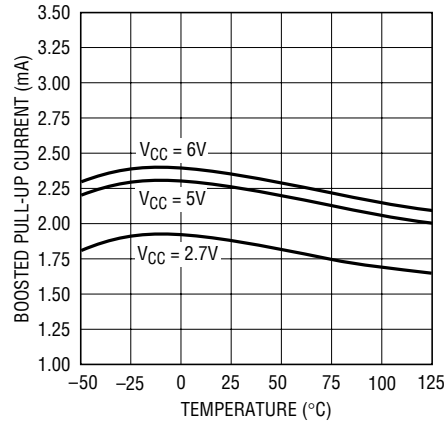

1694 G02

Boosted Pull-Up Current vs SMBus Voltage

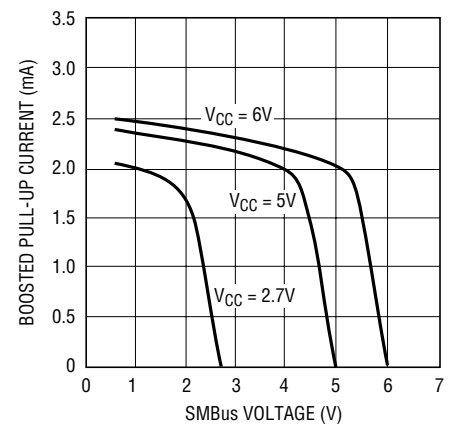

LT1694 G03

Input Threshold Voltage

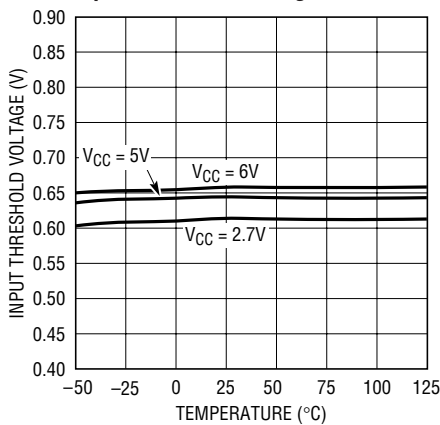

1694 G04

Slew Rate Detector Threshold

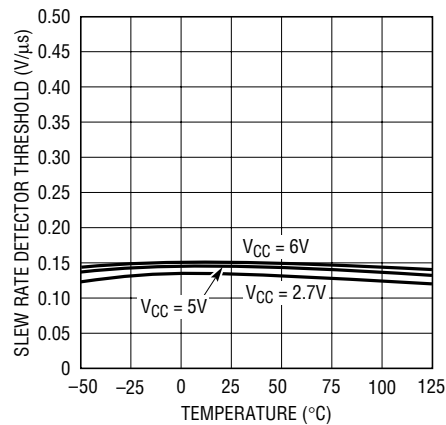

1694 G05

Standby Mode Supply Current

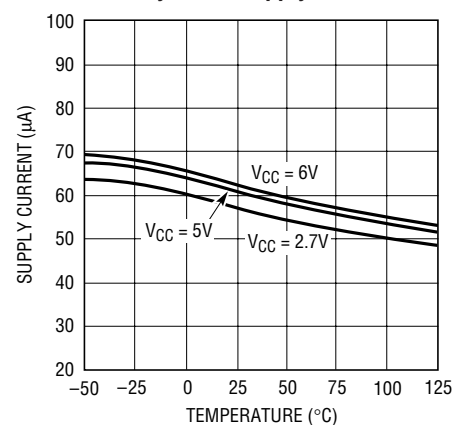

1694 G06

PIN FUNCTIONS

V_{CC} (Pin 1): Power Supply Input. V_{CC} can range from 2.7V to 6V and requires a 0.1µF bypass capacitor to GND.

GND (Pin 2): Ground.

NC (Pin 3): No Connection.

SMBus2 (Pin 4): Active pull-up for SMBus.

SMBus1 (Pin 5): Active pull-up for SMBus.

BLOCK DIAGRAM

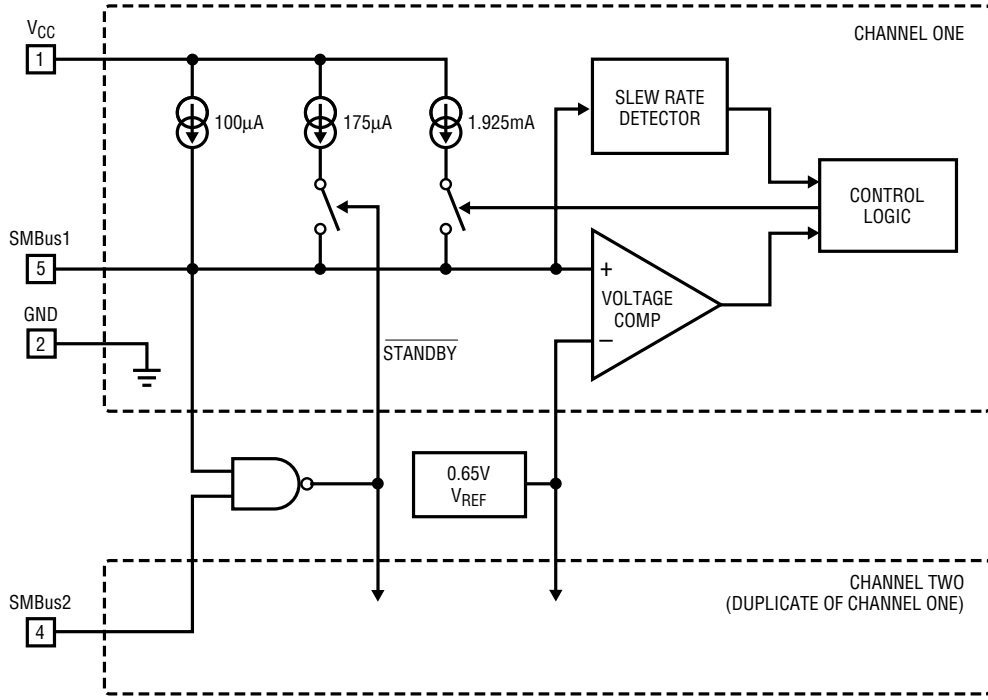

1694 BD

TEST CIRCUITS

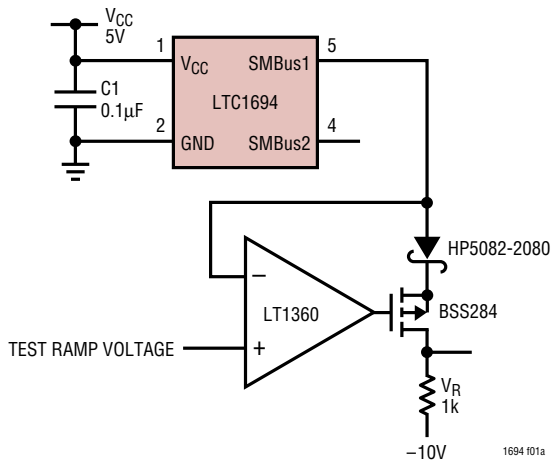

1694 101a

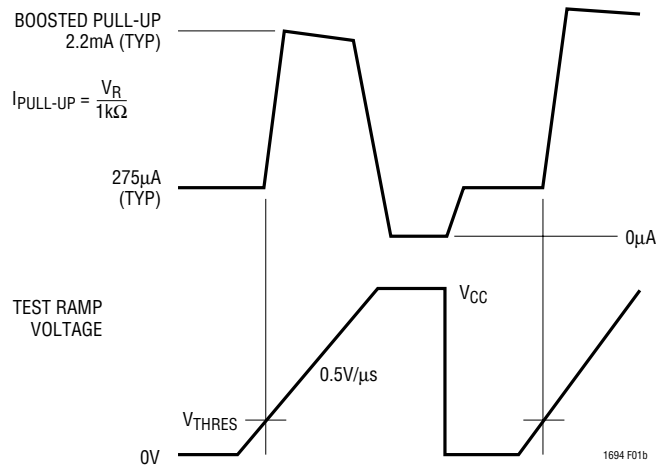

1694 F01b

Figure 1

APPLICATIONS INFORMATION

SMBus Overview

SMBus communication protocol employs open-drain drivers with resistive or current source pull-ups. This protocol allows multiple devices to drive and monitor the bus without bus contention. The simplicity of resistive or fixed current source pull-ups is offset by the slow rise times they afford when bus capacitance is high. Rise times can be improved by using lower pull-up resistor values or higher fixed current source values, but the additional current increases the low state bus voltage, decreasing noise margins. Slow rise times can seriously impact data reliability, enforcing a maximum practical bus speed well below the established SMBus maximum transmission rate.

Theory of Operation

The LTC1694 overcomes these limitations by using bilevel hysteretic current sources as pull-ups. During positive SMBus line transitions, the pull-up current sources typically provide 2.2mA to quickly slew any parasitic bus capacitance. Therefore, rise time is dramatically improved, especially with maximum SMBus loading conditions.

The LTC1694 has separate but identical circuitry for each SMBus output pin. The circuitry consists of a positive edge slew rate detector and a voltage comparator.

The LTC1694 nominally sources only 275 μ A of pull-up current to maintain good V_{OL} noise margin. The 2.2mA boosted pull-up current is only turned on if the voltage on the SMBus line is greater than the 0.65V comparator threshold voltage and the positive slew rate of the SMBus line is greater than the 0.2V/ μ s threshold of the slew rate detector. The boosted pull-up current remains on until the voltage on the SMBus line is within 0.5V of V_{CC} and/or the slew rate drops below 0.2V/ μ s.

Auto Detect Standby Mode

The LTC1694 enters standby mode if the voltage on both the SCL and SDA lines is high (idle state). In standby mode, the pull-up currents drop to 100 μ A, thereby lowering the system power consumption.

Maximum R_S Considerations

For ESD protection of the SMBus lines, a series resistor R_S (Figure 2) is sometimes added to the open-drain driver of the bus agents. This is especially common in SMBus-controlled smart batteries. The maximum value of R_S is limited by the low state noise margin and timing requirements of the SMBus specification. The maximum value for R_S is 700 Ω if resistive pull-ups or fixed value current sources are used.

In general, an R_S of 100 Ω to 200 Ω is sufficient for ESD protection while meeting both the low state noise margin and fall time requirement. If a larger value of R_S is required, take care to ensure that the low state noise margin and timing requirement of the SMBus specification is not violated. Also, the fall time of an SMBus line will also be increased by using a high value series resistor.

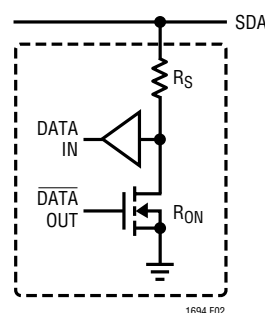

Figure 2

Low State Noise Margin

An acceptable V_{OL} noise margin is easily achieved with the low pull-up current (350 μ A maximum) of the LTC1694. The maximum value of R_S is calculated from a desired low state noise margin (NM_L):

$$R_{S(MAX)} = \frac{V_{OL(MAX)} - NM_L}{I_{PULL-UP(MAX)}} - R_{ON(MAX)} \quad (1)$$

$V_{OL(MAX)}$: The maximum V_{OL} of the SMBus specification is 0.4V

APPLICATIONS INFORMATION

$R_{ON(MAX)}$: The maximum on resistance of the open-drain driver

$I_{PULL-UP(MAX)}$: The maximum LTC1694 low pull-up current is 350 μ A

Fall Time

Fall time is a function of the SMBus capacitance, R_S , R_{ON} and the pull-up current. Figure 3 shows the maximum allowed ($R_S + R_{ON}$) based on the Intel SMBus fall time requirement of 300ns with a 50ns safety margin.

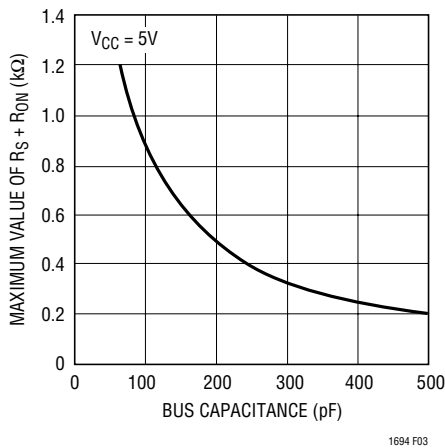

Figure 3. Maximum Value of $R_S + R_{ON}$ as a Function of Bus Capacitance for Meeting the SMBus $t_f(MAX)$ Requirement

The maximum value of R_S , based on fall time requirements, can also be calculated by rearranging equation 6. Given below are some equations that are useful for calculating rise and fall time and for selecting the value of R_S .

Initial Slew Rate

The initial slew rate, SR, of the Bus is determined by:

$$SR = I_{PULL-UP(MIN)}/C_{BUS} \quad (2)$$

C_{BUS} is the total capacitance of the SMBus line.

$I_{PULL-UP(MIN)}$ is the LTC1694 minimum pull-up current (125 μ A).

SR must be greater than SR_{THRES} , the LTC1694 slew rate detector threshold (0.5V/ μ s max) in order to activate the 2.2mA boosted pull-up current. This limits the maximum SMBus capacitance.

SMBus Rise Time

Rise time of an SMBus line is derived using equations 3, 4 and 5.

$$t_r = t_1 + t_2 \quad (3)$$

$$t_1 = (V_{THRES} - V_{IL(MAX)} + 0.15) \cdot C_{BUS}/I_{PULL-UP} \quad (4)$$

if $V_{IL(MAX)} - 0.15 > V_{THRES}$, then $t_1 = 0\mu$ s.

$$t_2 = (V_{IH(MIN)} + 0.15 - V_{THRES}) \cdot C_{BUS}/I_{PULL-UP(B)} \quad (5)$$

$I_{PULL-UP(B)}$ is the LTC1694 boosted pull-up current (2.2mA typ).

For an SMBus system, $V_{IL(MAX)} = 0.8V$ and $V_{IH(MIN)} = 2.1V$. For the LTC1694, typically $V_{THRES} = 0.65V$ and $I_{PULL-UP} = 275\mu$ A.

C_{BUS} is the total capacitance of the SMBus line.

SMBus Fall Time

Fall time of an SMBus line is derived using equation 6.

$$t_f = R_T \cdot C_{BUS} \cdot \ln\{[(0.9 \cdot V_{CC}) - (R_L \cdot I_{PULL-UP(LOW)})] / [V_{IL(MAX)} - 0.15 - (R_L \cdot I_{PULL-UP(LOW)})]\} \quad (6)$$

where R_L is the sum of R_S and R_{ON} (see Figure 2).

Rise and fall time calculation for an I²C system is as follows.

I²C Bus Rise and Fall Time

Rise time of an I²C line is derived using equation 7.

$$t_r = (V_{IH(MIN)} - V_{IL(MAX)}) \cdot C_{BUS}/I_{PULL-UP(B)} \quad (7)$$

Fall time of the I²C line can be derived using equation 8.

$$t_f = R_T \cdot C_{BUS} \cdot \ln\{[V_{IH(MIN)} - (R_L \cdot I_{PULL-UP})] / [V_{IL(MAX)} - (R_L \cdot I_{PULL-UP})]\} \quad (8)$$

For an I²C system with fixed input levels, $V_{IL(MAX)} = 1.5V$ and $V_{IH(MIN)} = 3V$.

For an I²C system with V_{CC} related input levels, $V_{IL(MAX)} = 0.3 \cdot V_{CC}$ and $V_{IH(MIN)} = 0.7 \cdot V_{CC}$.

C_{BUS} is the total capacitance of the I²C line.

APPLICATIONS INFORMATION

ACK Data Setup Time

The data setup time requirement for ACK (acknowledge) must be fulfilled if a high value of R_S is used. An acknowledge is accomplished by the SMBus host releasing the SDA line (pulling high) at the end of the last bit sent and the SMBus slave device pulling the SDA line low before the rising edge of the ACK clock pulse.

The LTC1694 2.2mA boosted pull-up current is activated when the SMBus host releases the SDA line, allowing the voltage to rise above the LTC1694's comparator threshold of 0.65V. If an SMBus slave device has a high value of R_S ,

a longer time is required for this SMBus slave device to pull SDA low before the rising edge of the ACK clock pulse.

To ensure sufficient data setup time for ACK, SMBus slave devices, with high values of R_S , should pull the SDA low earlier. Typically, a minimum setup time of 1.5 μ s is needed for an SMBus device with an R_S of 700 Ω and a bus capacitance of 200pF.

An alternative is that the SMBus slave device can hold SCL line low until the SDA line reaches a stable state. Then, SCL can be released to generate the ACK clock pulse.

PACKAGE DESCRIPTION

Dimensions in inches (millimeters) unless otherwise noted.

S5 Package 5-Lead Plastic SOT-23 (LTC DWG # 05-08-1633)

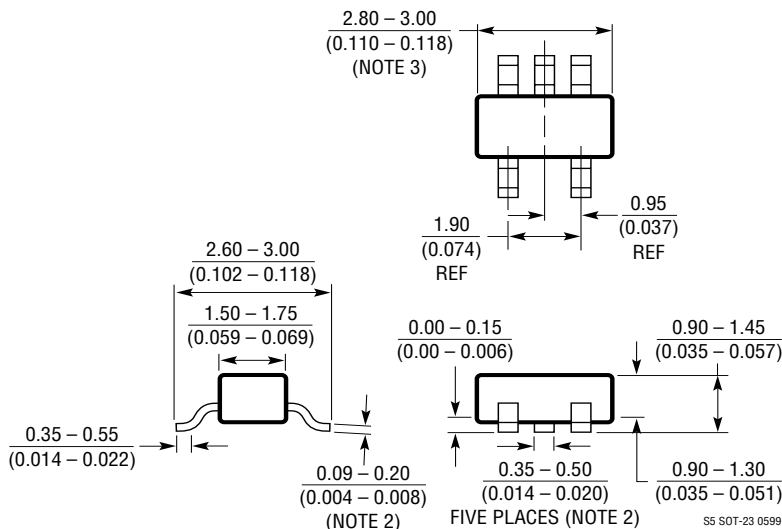

NOTE:

1. DIMENSIONS ARE IN MILLIMETERS
2. DIMENSIONS ARE INCLUSIVE OF PLATING
3. DIMENSIONS ARE EXCLUSIVE OF MOLD FLASH AND METAL BURR
4. MOLD FLASH SHALL NOT EXCEED 0.254mm
5. PACKAGE EIAJ REFERENCE IS SC-74A (EIAJ)

APPLICATIONS INFORMATION

Comparison of SMBus Waveforms for the LTC1694 vs Resistor Pull-Up

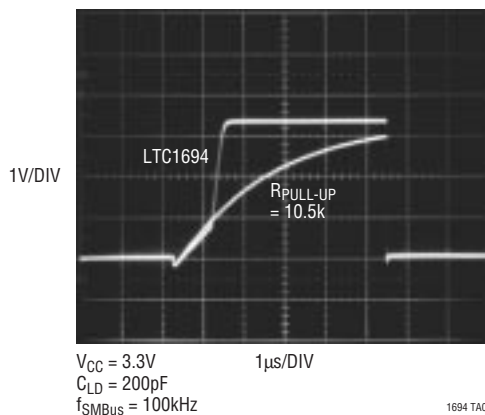
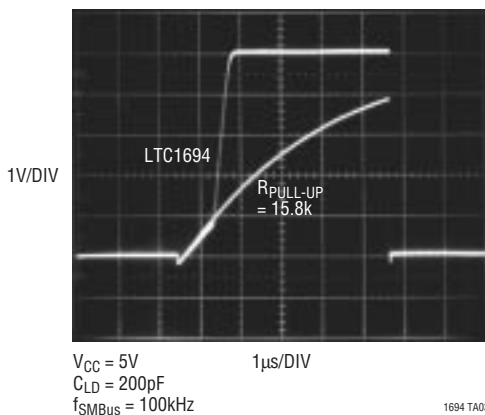

RELATED PARTS

PART NUMBER	DESCRIPTION	COMMENTS
LTC1380/LTC1393	8-Channel/4-Channel Analog Multiplexer with SMBus Interface	Low R_{ON} and Low Charge Injection
LTC1427-50	10-Bit Current DAC with SMBus Interface	50µA Full-Scale Current
LTC1623	Dual High Side Switch Controller with SMBus Interface	8 Selectable Addresses/16 Channel Capability
LTC1663	SMBus Interface 10-Bit Rail-to-Rail Micropower DAC	DNL < 0.75LSB Max, 5-Lead SOT-23 Package
LTC1694-1	SMBus/I ² C Accelerator	Includes AC Pull-Up Current Only
LTC1695	SMBus/I ² C Fan-Speed Controller in SOT-23	0.75Ω PMOS Linear Regulator with 180mA Output Current, SMBus-Controlled 6-Bit DAC
LTC1710	SMBus Dual High Side Switch	Two 0.4Ω, 300mA N-Channel Switches
LTC1759	Single Chip Smart Battery Charger Controller with SMBus Interface	94% Efficiency with Input Current Limiting, Up to 8A I_{CHG}
LT1786F	SMBus-Controlled CCFL Switching Regulator	1.25A, 200kHz, Floating or Grounded Lamp Configurations