

LT8500/LT3595A 48-Channel LED Driver with PWM Generator and Serial Interface

DESCRIPTION

This demonstration circuit showcases the LT8500, a 48-channel LED driver with a PWM generator and serial interface. It operates from a 30V to 45V input power supply and drives 48 channels of LED strings at 30mA and up to 32V each, although it can be adjusted for 50mA per string. The LT8500 drives 48 PWM channels that are tied directly to the PWM inputs of the three separate LT3595As. The LT3595A is a 16-channel step-down LED driver that can operate up to 45V input and up to 50mA per channel. The input to the LT8500 is a serial interface that can run up to 50MHz. The DC1552A has both an input and output connector and can be cascaded in a chain of two or more while being driven from a single serial interface. DC1552A is assembled as a solo 48-channel LED driver, but with a few simple modifications, it can be turned into one of the elements in a cascaded chain of DC1552As.

The LT8500 is a pulse width modulation (PWM) generator with 48 independent channels. Each channel has an individually adjustable 12-bit (4096-step) PWM register and a 6-bit (64-step) $\pm 50\%$ correction register. All controls are programmable via a simple serial data interface. Three banks of 16-channels each can be configured such that they operate 120 degrees out-of-phase with each other.

The LT8500 features two diagnostic information flags: synchronization error and open LED. The flags are sent, with additional state information, on the serial data interface

during status read back. The 50MHz cascadable serial data interface includes buffering and skew-balancing, making the chip suitable for PWM intensive applications such as large screen LCD dynamic backlighting and mono-, multi- and full-color LED displays. The LT8500 is also ideally suited to control three LT3595A LED drivers.

The LT3990 is a small 350mA step-down regulator with integrated power switch and diodes that operates up to 62V_{IN}. Its 3mm × 3mm 16 pin MSOP and integrated components are a good housekeeping power supply to be used for 3.3V power on the LT8500 and it's surrounding logic buffers.

The LT8500, LT3595A, and LT3990 data sheets give complete descriptions of the parts, operation and applications information. The data sheets must be read in conjunction with this demo manual for DC1552A. The LT8500 and LT3595A are both assembled in 56 pin (5mm × 9mm × 0.75mm) QFN packages. Proper board layout is essential for both maximum thermal performance and signal noise immunity. See the layout considerations sections in the data sheets for more details.

Design files for this circuit board are available at <http://www.linear.com/demo>

LT, LT, LTC, LTM, Linear Technology and the Linear logo are registered trademarks of Linear Technology Corporation. All other trademarks are the property of their respective owners.

DEMO MANUAL DC1552A

QUICK START PROCEDURE

Demonstration circuit 1552A is easy to set up to evaluate the performance of the LT8500 and LT3595A. Follow the procedure for testing a single DC1552A without chaining multiple boards together.

NOTE: Make sure that the P_{VIN} DC input voltage does not exceed 45V. A hot-plugged input above 40V can result in damage to the IC with input voltage ringing.

1. Connect a panel of LEDs to the output connector P1 of DC1552A. The LED strings should be between 2 LEDs per string up to about 32V of LEDs per string. There is room for 48 strings of LEDs to be connected to a single DC1552A.
2. Connect the serial data interface to connector P3.

3. With power off, connect the P_{VIN} power supply to the P_{VIN} and GND connection on P2.
4. Turn the P_{VIN} power supply on.
5. Begin sending and receiving serial data from the serial interface.
6. Observe the LED string running at the programmed LED current and the patterns on the LED panel.

In order to tie multiple DC1552A LED drivers together in a chain, follow the recommended component setup in Table 1. Repeat the Quick-Start Procedure, but connect the serial output of one DC1552A PCB to the serial input of the next in the chain with a cable from the P4 output on the PCB to the P3 input of the next PCB before power-up.

HARDWARE SETUP

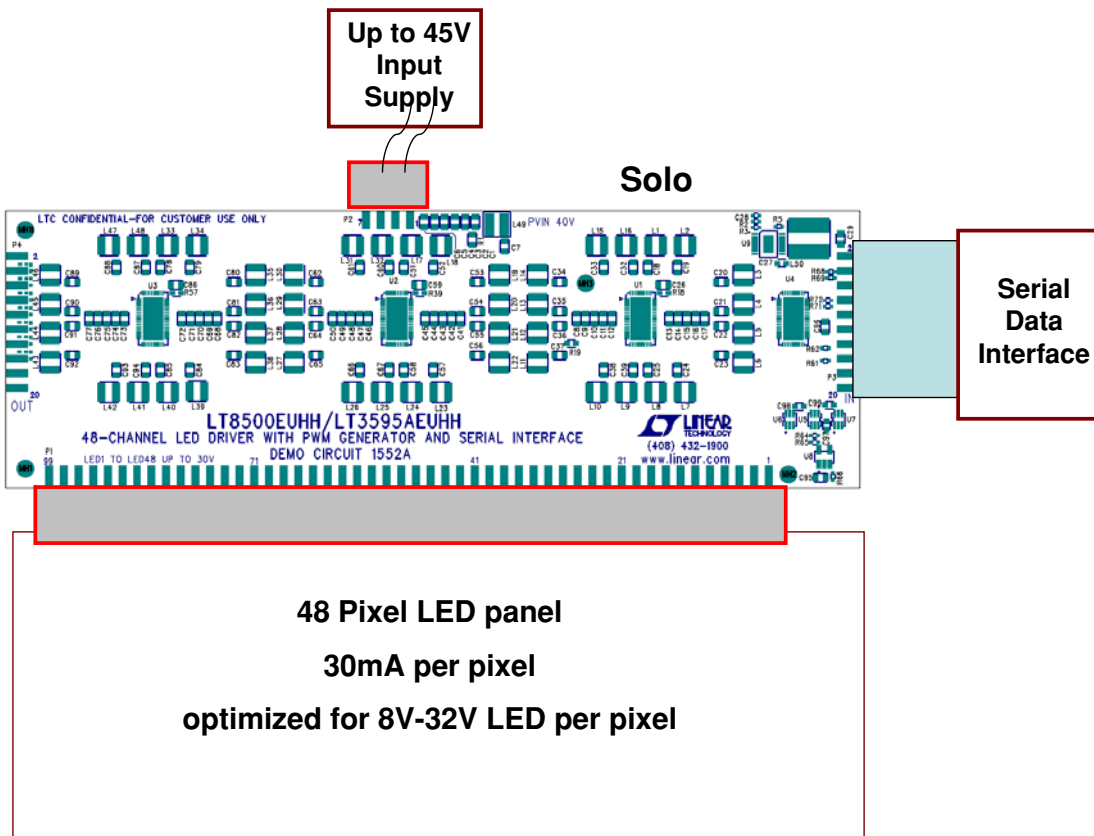

Figure 1. Typical Hardware Setup for Testing a Single DC1552A as a 48 Pixel LED Driver

HARDWARE SETUP

DC1552A Solo (as Assembled without Chaining)

DC1552A is assembled as a solo PCB. It is setup to be run with a serial interface and not cascaded in a chain without making a few resistor changes. When setup as solo or the first element in a chain, a clock needs to be provided for

the pwm clock signal. The LTC1799 is placed on the solo or first cascaded PCB, but does not have to be present on ensuing PCBs in a chain. Output signals and serial data output is returned to the serial interface directly from the solo PCB as assembled.

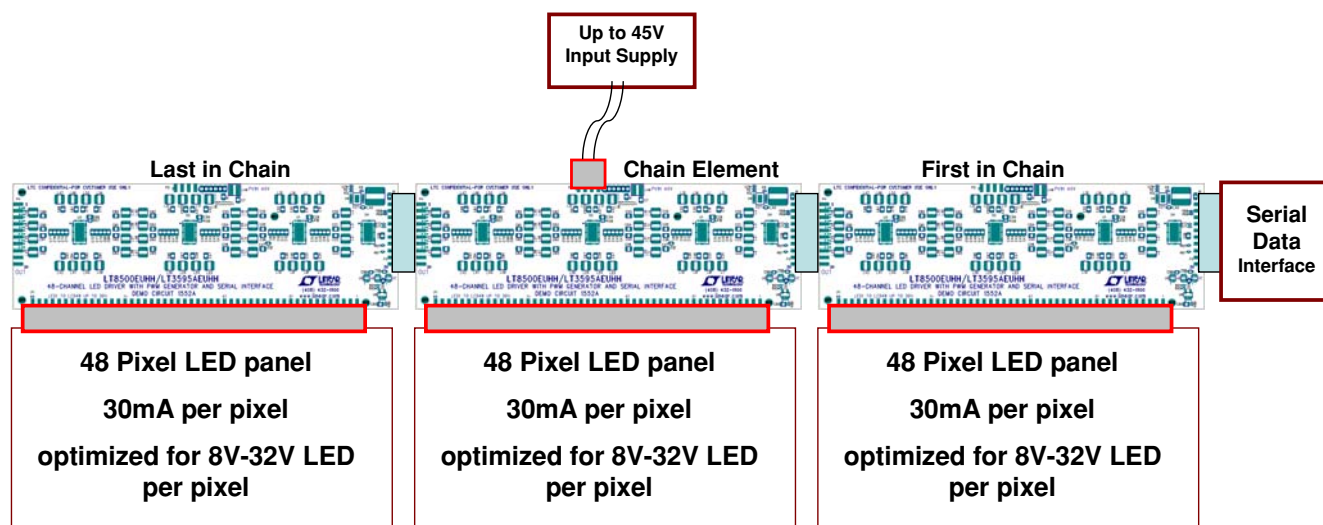

Figure 2. Hardware Setup for Testing the DC1552A in a Chain for Driving 144 Pixels of LEDs

DC1552A Cascaded in Chain

If more than one DC1552A is needed for a cascaded chain, the PCBs can be tied together. The main power can be derived from a single input since the 40V power is passed from one DC1552A to another next to the serial connection. Alterations to several components should be made to DC1552A to change the PCB from solo setup as assembled to a chain setup. A different set of changes should be made to change the PCB from solo to first in chain, last in chain, or to an element in the chain that is not first or last.

To change DC1552A from solo (as assembled) to first in chain, last in chain or a cascaded chain element, please follow the recommendations in the table below. The first in chain must have the PWM clock to be provided for all of the PCBs down the chain. The last element in the chain must take the output data and send it back to the previous PCB.

Table 1. Recommended Component Changes for Chaining Multiple DC1552As Together

	U8, R65, R66, C95	R61, R68	R62, R69	U5, C97	R64	U6, C98, R72	R71	U7, C99
Solo (as Assembled)	LTC1799, 0Ω, 24.9kΩ, 1μF	OPT	0Ω	NC7WZ17P6X, 1μF	OPT	OPT	0Ω	OPT
First in Chain	LTC1799, 0Ω, 24.9kΩ, 1μF	0Ω	OPT	NC7WZ17P6X, 1μF	OPT	NC7WZ17P6X, 1μF, 0Ω	OPT	NC7WZ17P6X, 1μF
Chain Element	OPT	0Ω	OPT	NC7WZ17P6X, 1μF	0Ω	NC7WZ17P6X, 1μF, 0Ω	OPT	NC7WZ17P6X, 1μF
Last in Chain	OPT	OPT	0Ω	NC7WZ17P6X, 1μF	0Ω	OPT	0Ω	OPT

OPT = Optional, do not stuff

DEMO MANUAL DC1552A

PARTS LIST

ITEM	QTY	REFERENCE	PART DESCRIPTION	MANUFACTURER/PART NUMBER
Required Circuit Components				
1	7	C1-C7	CAP., X7R, 0.33 μ F, 50V, 10%, 0805	MURATA, GRM219R71H334KA88D
2	78	C8-C25, C32-C39, C41-C58, C60-C85, C87-C94	CAP., X7R, 0.47 μ F, 50V, 10%, 0805	MURATA, GRM21BR71H474KA88L
3	4	C26, C59, C86, C96	CAP., X7R, 10 μ F, 10V, 10%, 0805	MURATA, GRM21BR71A106KE51L
4	1	C27	CAP., X5R, 0.22 μ F, 16V, 10%, 0603	TAIYO YUDEN, EMK107BJ224KA-T
5	1	C28	CAP., C0G, 22pF, 25V, 10%, 0402	AVX, 04023A220KAT2A
6	1	C29	CAP., X7R, 22 μ F, 6.3V, 20%, 0805	TAIYO YUDEN, JDK212BJ226MD-T
7	1	C95	CAP., X7R, 1 μ F, 10V, 10%, 0805	MURATA, GRM21BR71A105KA01L
8	1	C97	CAP., X7R, 1 μ F, 6.3V, 20%, 0603	AVX, 06036C105MAT2A
9	0	C98, C99 (OPT)	CAP., 0603	
10	1	L49	IND. PWR, 10 μ H, L-LPO3310	COILCRAFT, LPO3310-103MLC
11	48	L1-L48	IND., 100 μ H, 1212	MURATA, LQH3NPN101MG0L
12	1	L50	IND., 33 μ H	COILCRAFT, LPS6225-333ML
13	1	P1	HEADER, 2X50, 0.100"	SAMTEC, TSW-150-07-L-D
14	1	P2	HEADER, 2X4, 0.100"	SAMTEC, TSW-104-07-L-D
15	2	P3, P4	HEADER, 2X10, 0.100"	SAMTEC, TSW-110-07-L-D
16	1	R1	RES., 4.99 Ω , 1/8W, 1%, 0805	VISHAY, CRCW08054R99FNEA
17	1	R2	RES., 1.00M, 1/16W, 0402, 1%	VISHAY, CRCW04021M00FKED
18	1	R3	RES., 576k, 1/16W, 1%, 0402	VISHAY, CRCW0402576KFKED
19	1	R5	RES., 374k, 1/16W, 0402, 1%	VISHAY, CRCW0402374KFKED
20	3	R18, R39, R57	RES., 49.9k, 1/10W, 1%, 0603	VISHAY, CRCW060349K9FKEA
21	0	R61, R64, R68, R72 (OPT)	RES., 0603	
22	1	R19	RES., 33k, 1/10W, 1%, 0603	VISHAY, CRCW060333K0FKEA
23	4	R62, R65, R69, R71	RES., 0 Ω , 1/10W, 0402	VISHAY, CRCW04020000Z0EA
24	1	R66	RES., 24.9k, 1/16W, 1%, 0402	VISHAY, CRCW040224K9FKED
25	3	U1-U3	IC., LT3595AEUHH, QFN56UHH-5X9	LINEAR TECH., LT3595AEUHH
26	1	U4	IC., LT8500EUHH, QFN56UHH-5X9	LINEAR TECH., LT8500EUHH
27	1	U5	IC., TinyLogic UHS Dual Buffer, SC70-6	FAIRCHILD SEMI., NC7WZ17P6X
28	0	U6, U7 (OPT)	IC., TinyLogic UHS Dual Buffer, SC70-6	
29	1	U8	IC., LTC1799CS5, SOT23-5	LINEAR TECH., LTC1799CS5
30	1	U9	IC., LT3990EMSE, MSE16 (1rl.+2 tubes)	LINEAR TECH., LT3990EMSE
31	1		FAB, PRINTED CIRCUIT BOARD	DEMO CIRCUIT 1552A
32	1		STENCIL TOP SIDE ONLY	STENCIL 1552A

SCHEMATIC DIAGRAM

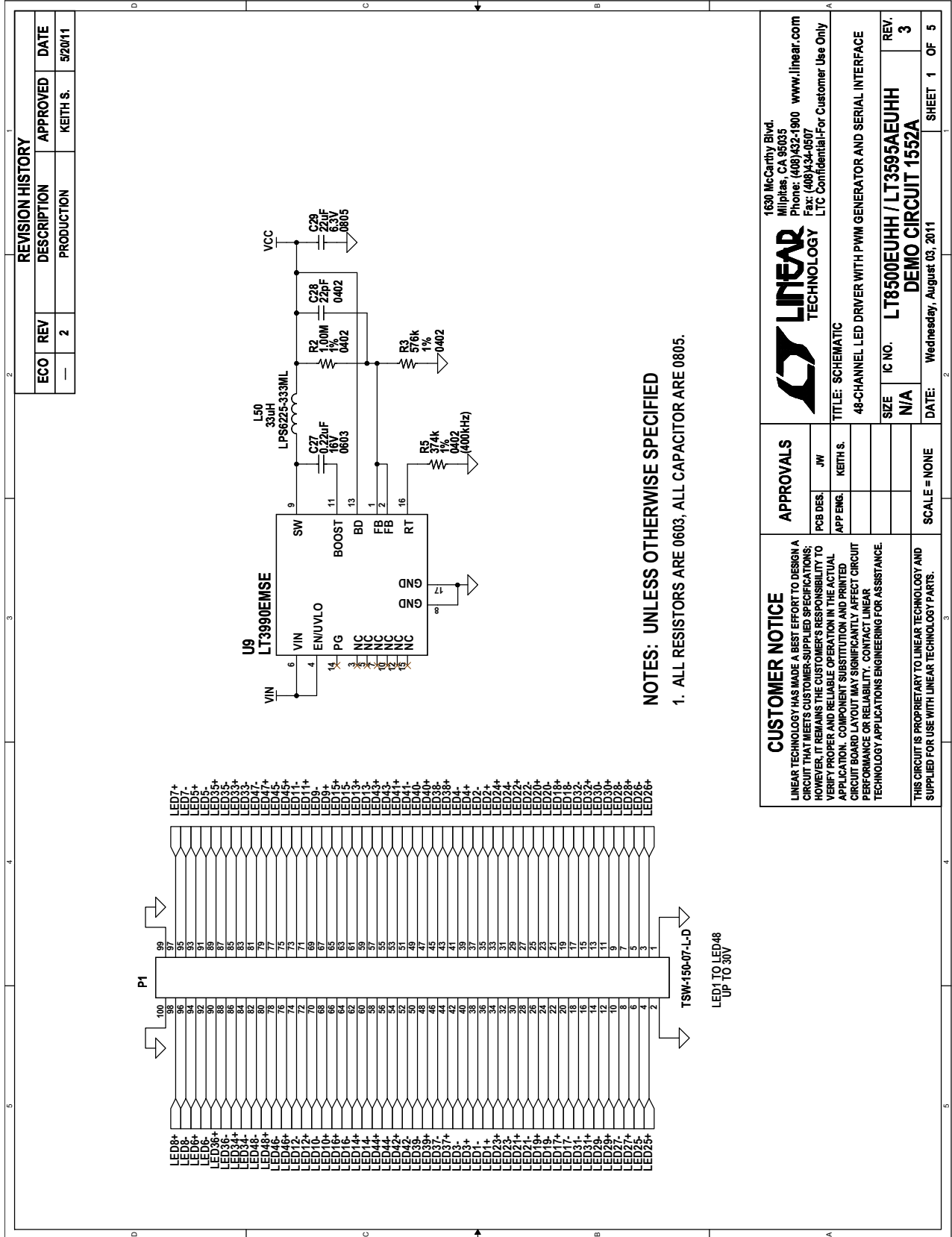

SCHEMATIC DIAGRAM

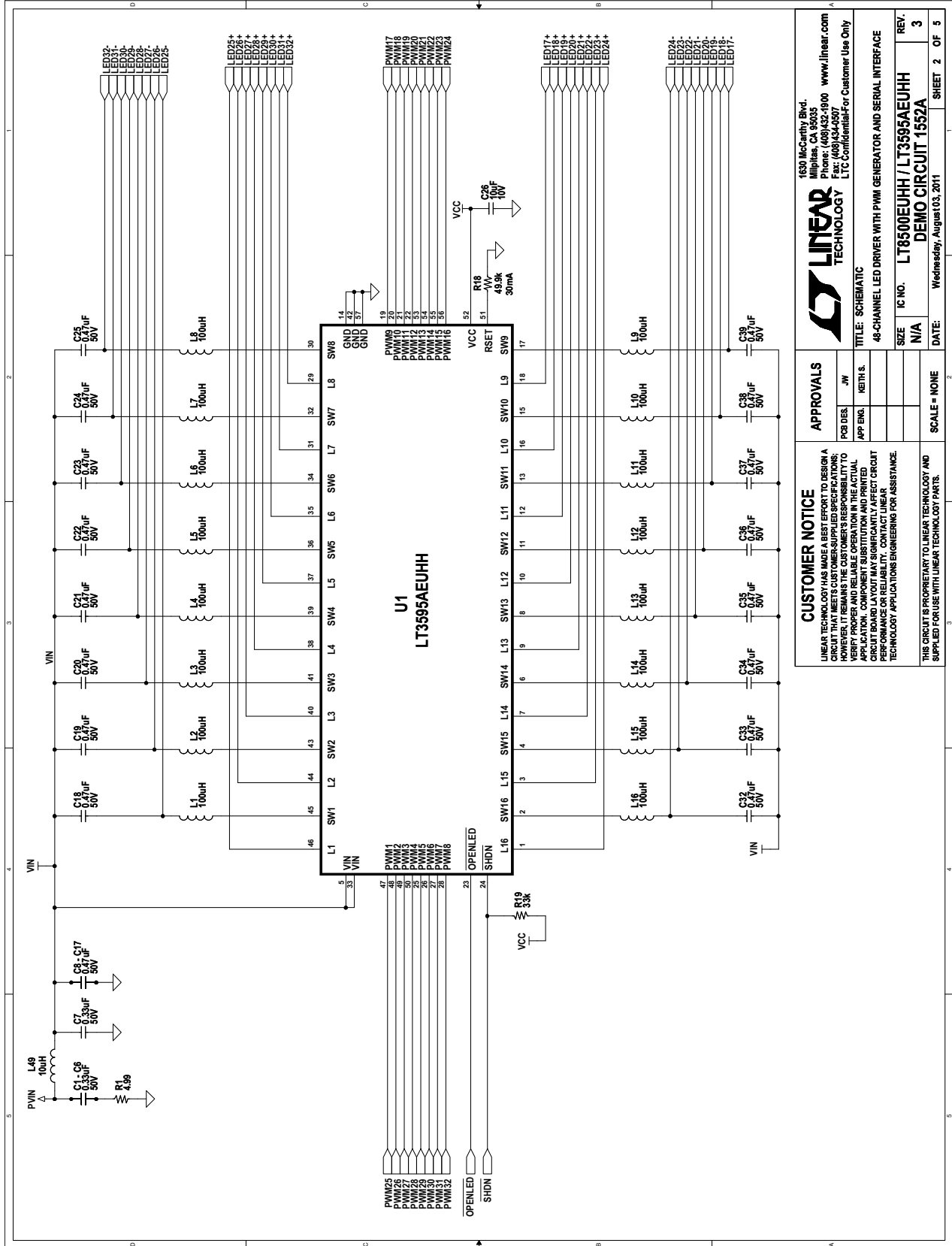

1630 McCarthy Blvd.
 Milpitas, CA 95035
 Phone: (408)432-1900 www.linear.com
 Fax: (408)434-0907
 LTC Confidential/For Customer Use Only

LINEAR TECHNOLOGY

TITLE: SCHEMATIC
 48-CHANNEL LED DRIVER WITH PWM GENERATOR AND SERIAL INTERFACE

SIZE	IC NO.	REV.
N/A	LT8500EUHH / LT395AEUHH	3

DEMO CIRCUIT 1552A

DATE: Wednesday, August 10, 2011 SHEET 2 OF 5

APPROVALS

POB DES.	JW
APP ENG.	KEITH S.

SCALE = NONE

CUSTOMER NOTICE
 LINEAR TECHNOLOGY HAS MADE A BEST EFFORT TO DESIGN A CIRCUIT THAT MEETS CUSTOMER-SUPPLIED SPECIFICATIONS; HOWEVER, IT REMAINS THE CUSTOMER'S RESPONSIBILITY TO VERIFY PROPER AND RELIABLE OPERATION IN THE ACTUAL APPLICATION. ANY CHANGES TO THE ORIGINAL CIRCUIT BOARD LAYOUT MAY SIGNIFICANTLY AFFECT CIRCUIT PERFORMANCE OR RELIABILITY. CONTACT LINEAR TECHNOLOGY APPLICATIONS ENGINEERING FOR ASSISTANCE.

THIS CIRCUIT IS PROPRIETARY TO LINEAR TECHNOLOGY AND SUPPLIED FOR USE WITH LINEAR TECHNOLOGY PARTS.

SCHEMATIC DIAGRAM

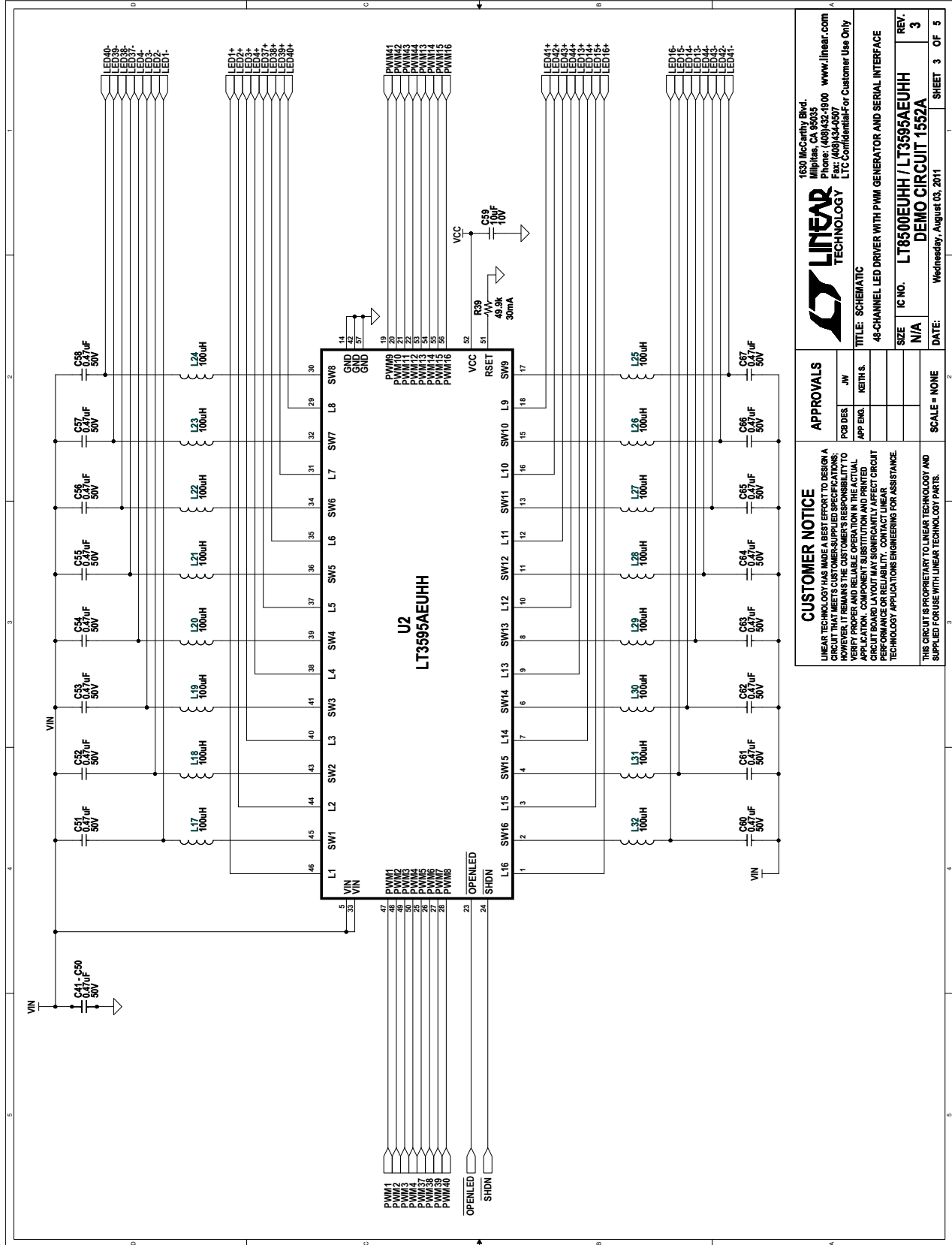

DEMO MANUAL DC1552A

SCHEMATIC DIAGRAM

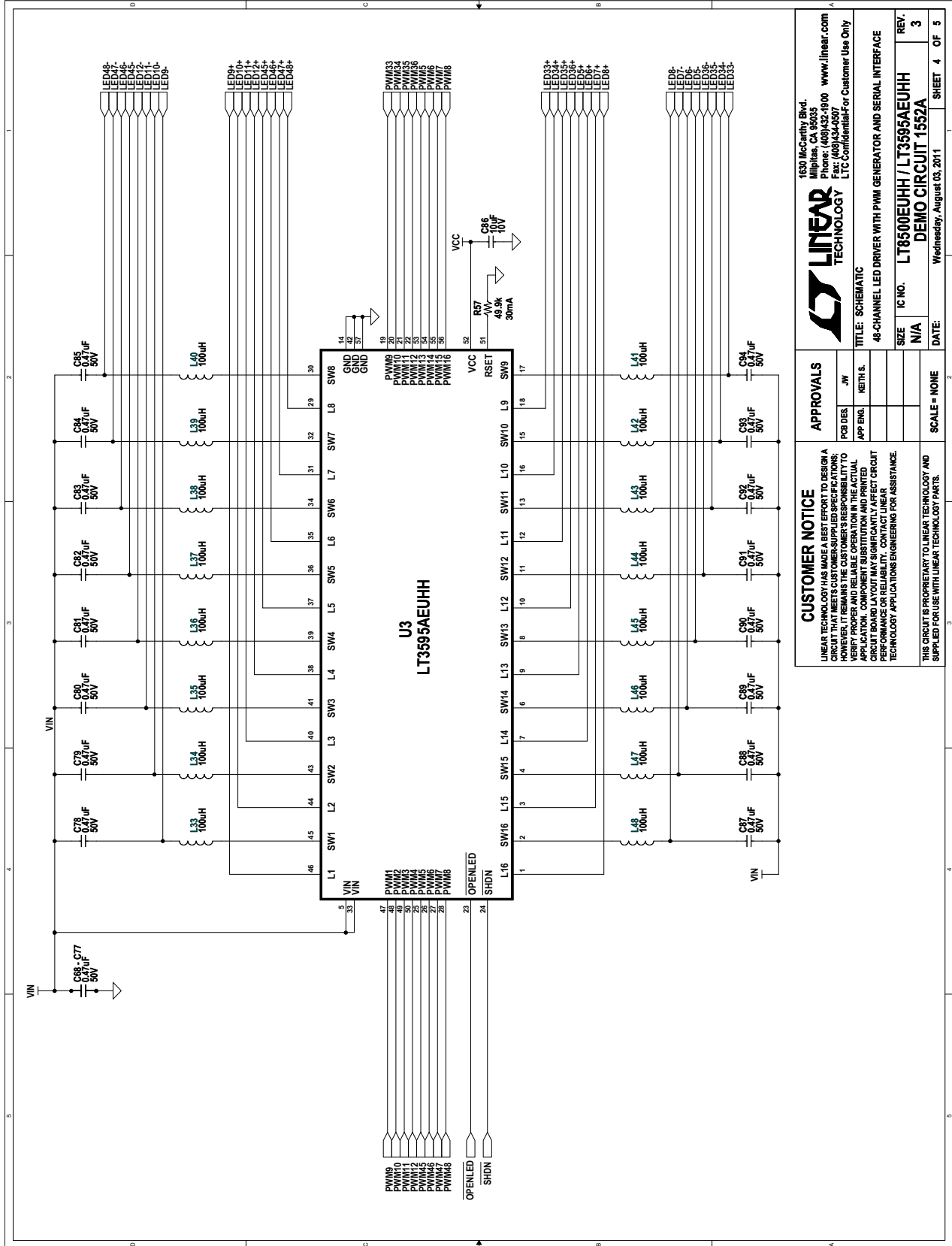

DEMO MANUAL DC1552A

DEMONSTRATION BOARD IMPORTANT NOTICE

Linear Technology Corporation (LTC) provides the enclosed product(s) under the following **AS IS** conditions:

This demonstration board (DEMO BOARD) kit being sold or provided by Linear Technology is intended for use for **ENGINEERING DEVELOPMENT OR EVALUATION PURPOSES ONLY** and is not provided by LTC for commercial use. As such, the DEMO BOARD herein may not be complete in terms of required design-, marketing-, and/or manufacturing-related protective considerations, including but not limited to product safety measures typically found in finished commercial goods. As a prototype, this product does not fall within the scope of the European Union directive on electromagnetic compatibility and therefore may or may not meet the technical requirements of the directive, or other regulations.

If this evaluation kit does not meet the specifications recited in the DEMO BOARD manual the kit may be returned within 30 days from the date of delivery for a full refund. **THE FOREGOING WARRANTY IS THE EXCLUSIVE WARRANTY MADE BY THE SELLER TO BUYER AND IS IN LIEU OF ALL OTHER WARRANTIES, EXPRESSED, IMPLIED, OR STATUTORY, INCLUDING ANY WARRANTY OF MERCHANTABILITY OR FITNESS FOR ANY PARTICULAR PURPOSE. EXCEPT TO THE EXTENT OF THIS INDEMNITY, NEITHER PARTY SHALL BE LIABLE TO THE OTHER FOR ANY INDIRECT, SPECIAL, INCIDENTAL, OR CONSEQUENTIAL DAMAGES.**

The user assumes all responsibility and liability for proper and safe handling of the goods. Further, the user releases LTC from all claims arising from the handling or use of the goods. Due to the open construction of the product, it is the user's responsibility to take any and all appropriate precautions with regard to electrostatic discharge. Also be aware that the products herein may not be regulatory compliant or agency certified (FCC, UL, CE, etc.).

No License is granted under any patent right or other intellectual property whatsoever. **LTC assumes no liability for applications assistance, customer product design, software performance, or infringement of patents or any other intellectual property rights of any kind.**

LTC currently services a variety of customers for products around the world, and therefore this transaction **is not exclusive**.

Please read the DEMO BOARD manual prior to handling the product. Persons handling this product must have electronics training and observe good laboratory practice standards. **Common sense is encouraged.**

This notice contains important safety information about temperatures and voltages. For further safety concerns, please contact a LTC application engineer.

Mailing Address:

Linear Technology
1630 McCarthy Blvd.
Milpitas, CA 95035

Copyright © 2004, Linear Technology Corporation