

LT8495 SEPIC/Boost Converter with 2A, 70V Switch, 9 μ A Quiescent Current, POR and Watchdog Timer

DESCRIPTION

Demonstration circuit 2205A is a monolithic SEPIC converter featuring LT[®]8495. The demo board is designed for 5V output from a 3V to 60V input at 450kHz switching frequency. The max output current is 1A when the input voltage is above 12V, and is reduced with lower input voltage. The LT8495 is a monolithic switching regulator with a power-on reset and watchdog timer. Quiescent current can be less than 9 μ A when operating. Dual supply pins (V_{IN} and BIAS) allow the part to automatically operate from the most efficient supply.

The switching regulation, watchdog timer and reset detection functions are controlled by the SWEN, WDE and RSTIN respectively. The reset and watchdog timeout periods are independently adjustable using external capacitors C5 and C6. The watchdog timer is enabled by default on the demo board, and it can be disabled by moving the JP1 to GND.

Low Ripple Burst Mode[®] operation increases the efficiency at the light load while keeping the output ripple below 10mV. Figure 1 shows the demo board efficiency at 12V input voltage. Figure 2 shows the max load current with different input voltages of the demo board.

The LT8495 data sheet gives a complete description of the part, operation and application information. The data sheet must be read in conjunction with this demo manual for demo circuit 2205A. The LT8495 is assembled in a 20-lead plastic TSSOP package. Proper board layout is essential for maximum thermal and electrical performance. See the data sheet sections for details.

Design files for this circuit board are available at <http://www.linear.com/demo/DC2205A>

LT, LT, LTC, LTM, Linear Technology, the Linear logo and Burst Mode are registered trademarks of Linear Technology Corporation. All other trademarks are the property of their respective owners.

PERFORMANCE SUMMARY Specifications are at $T_A = 25^\circ\text{C}$

SYMBOL	PARAMETER	CONDITIONS	MIN	TYP	MAX	UNITS
V_{IN}	Input Supply Range		3		60	V
V_{OUT}	Output Voltage		4.86	5.04	5.24	V
f_{SW}	Switching Frequency	$R_T = 169\text{k}\Omega$	414	450	477	kHz
I_{OUT}	Max Output Current	$V_{IN} = 12\text{V}$	1			A
E_{FE}	Efficiency at DC	$V_{IN} = 12\text{V}, I_{OUT} = 1\text{A}$		80.2		%

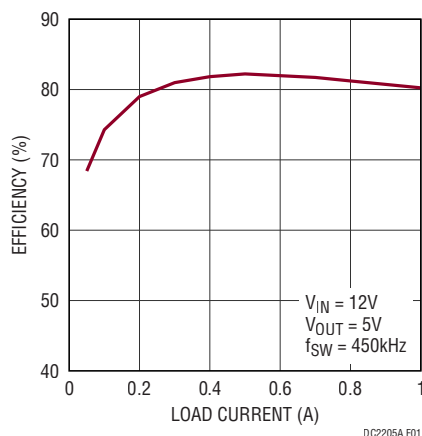

Figure 1. LT8495 Efficiency

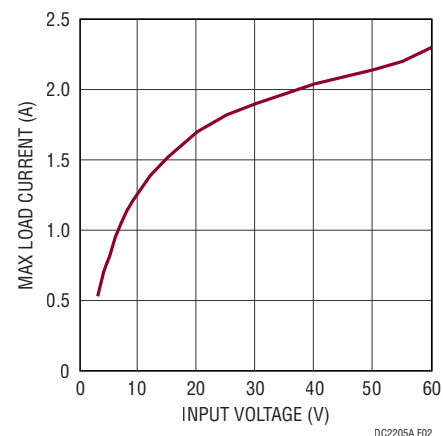

Figure 2. LT8495 Max Load Current (Typical) vs Input Voltage

dc2205afa

QUICK START PROCEDURE

Demonstration circuit 2205A is easy to set up to evaluate the performance of the LT8495. Refer to Figure 3 for proper measurement equipment setup and follow the procedure below.

Note. When measuring the input or output voltage ripple, care must be taken to avoid a long ground lead on the oscilloscope probe. Measure the input or output voltage ripple by touching the probe tip directly across the V_{IN} or V_{OUT} and GND terminals. See Figure 4 for the proper scope technique.

1. Place JP1 on the \overline{RST} position to enable the watchdog timer. It can be disabled by placing JP1 on the GND position.

2. With power off, connect the input power supply to V_{IN} and GND. Make sure that the input voltage does not exceed 60V.
3. With power off, connect loads from V_{OUT} to GND.
4. Turn on the power at the input.
5. Check for the proper output voltages ($V_{OUT} = 5V$).

Note. If there is no output, temporarily disconnect the load to make sure that the load is not set too high or is shorted.

6. Once the proper output voltages are established, adjust the load within the operating ranges and observe the output voltage regulation, ripple voltage, efficiency and other parameters.

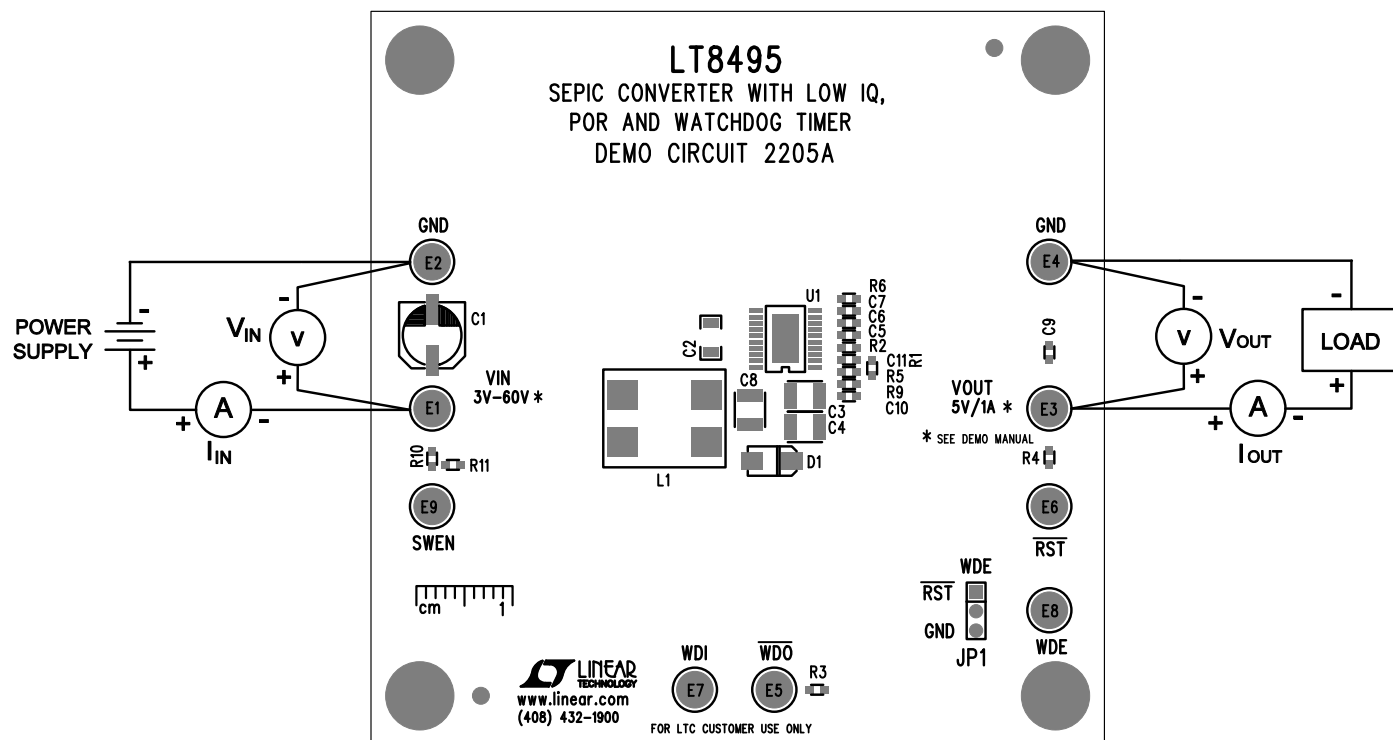

Figure 3. Proper Measurement Equipment Setup

QUICK START PROCEDURE

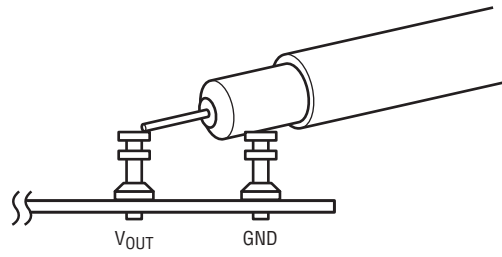

Figure 4. Measuring Input or Output Ripple

DEMO MANUAL DC2205A

PARTS LIST

ITEM	QTY	REFERENCE	PART DESCRIPTION	MANUFACTURER/PART NUMBER
Required Demo Board Circuit Components				
1	1	C2	CAP., 2.2 μ F, X7R, 100V, 10%,1206	AVX, 12061C225KAT2A
2	2	C3, C4	CAP., 47 μ F, X5R, 10V, 1210	MURATA, GRM32ER61A476KE20L
3	1	C5	CAP., 4.7nF, X7R, 50V, 10%, 0603	AVX, 06035C472KAT2A
4	1	C6	CAP., 1nF, X7R, 25V, 10%, 0603	AVX, 06033C102KAT2A
5	2	C7, C9	CAP., 1 μ F 20% 25V X5R 0603	AVX, 06033D105MAT2A
6	1	C8	CAP., 2.2 μ F, X7R, 100V, 10%, 1210	AVX,12101C225KAT2A
7	1	C11	CAP., 4.7pF, C0G, 50V, \pm .25pF, 0603	MURATA, GRM1885C1H4R7CA01D
8	1	D1	DIODE, SCHOTTKY, 2A, 100V, SMA	ON SEMI., MBRA2H100T3G
9	1	L1	IND, 15 μ H, 20%	VISHAY, IHCL4040DZER150M5A
10	2	R1, R10	RES., 1M, 1/10W, 1%, 0603	VISHAY, CRCW06031M00FKEA
11	1	R2	RES., 316k,1/10W, 1%, 0603	VISHAY, CRCW0603316KFKEA
12	2	R3, R4	RES., 100k, 1/10W, 1%, 0603	VISHAY, CRCW0603100KFKEA
13	1	R5	RES., 8.87k,1/10W, 1%, 0603	VISHAY, CRCW06038K87FKEA
14	1	R6	RES., 169k,1/10W, 1%, 0603	VISHAY, CRCW0603169KFKEA
15	1	R9	RES., 0 Ω , 1/10W, 0603	VISHAY, CRCW06030000Z0EA
16	1	U1	I.C., LT8495EFE, TSSOP20FE	LINEAR TECH., LT8495EFE#PBF
Additional Demo Board Circuit Components				
1	1	C1	CAP., ALUM., ELECT., 10 μ F, 63V	SUN ELECTRONIC INDUSTRIES CORP., 63CE10BS
2	0	C10	CAP., OPTION, 0603	OPT
3	0	R11	RES., OPTION, 0603	OPT
Hardware/Components (for Demo Board Only)				
1	9	E1-E9	TP, TURRET, 0.094"	MILL-MAX, 2501-2-00-80-00-00-07-0
2	1	JP1	CONN., HEADER, 1X3, 2mm	WÜRTH, 62000311121
3	1	XJP1	SHUNT, 2mm	WÜRTH, 60800213421

SCHEMATIC DIAGRAM

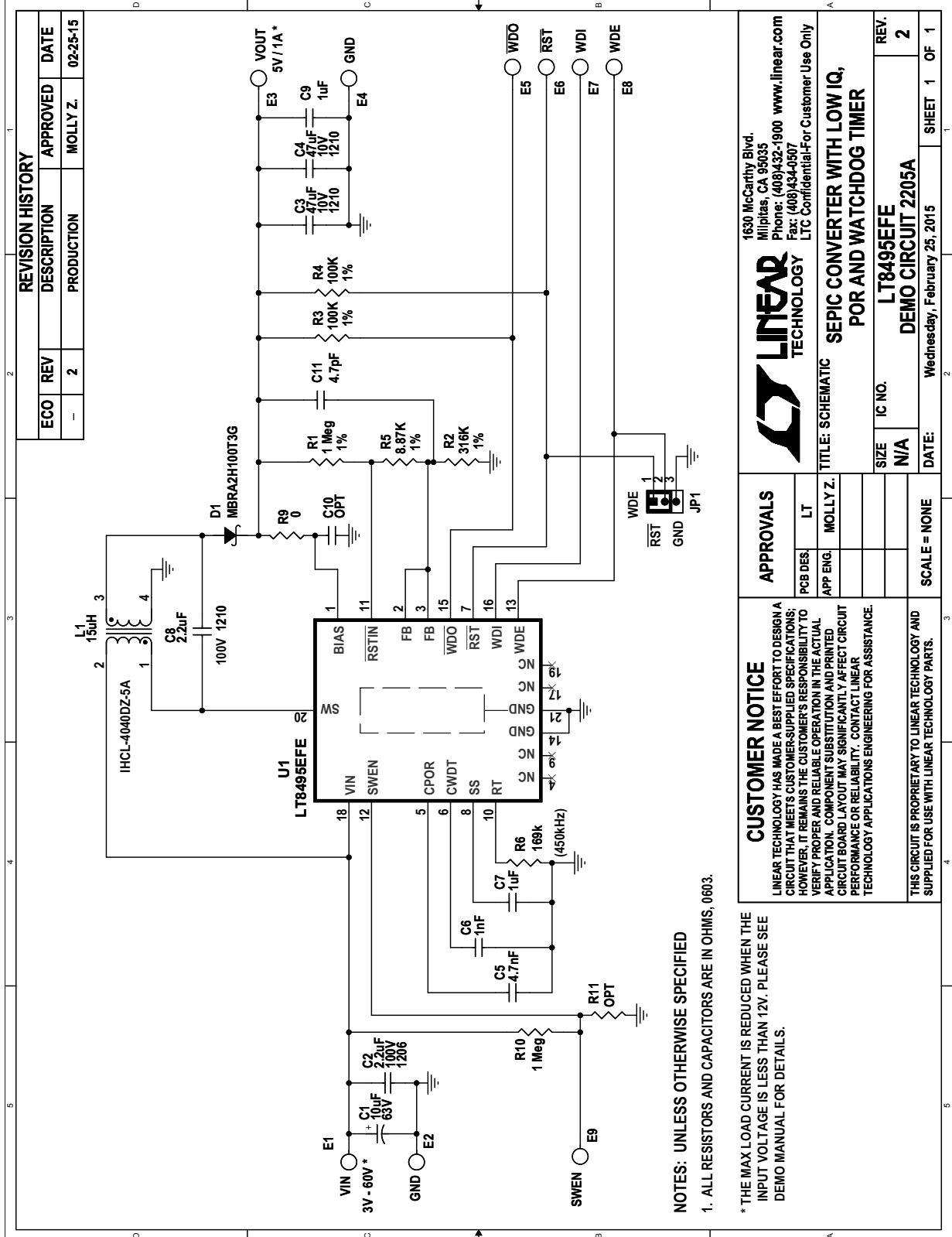

REVISION HISTORY				
ECO	REV	DESCRIPTION	APPROVED	DATE
-	2	PRODUCTION	MOLLY Z.	02-25-15

		1630 McCarthy Blvd. Milpitas, CA 95035 Phone: (408)432-1900 www.linear.com Fax: (408)434-0907 LTC Confidential-For Customer Use Only	
TITLE: SCHEMATIC SEPIC CONVERTER WITH LOW IQ, POR AND WATCHDOG TIMER			
SIZE	IC NO.	REV.	
N/A	LT8495EFE	2	
DATE:		SHEET 1 OF 1	
Wednesday, February 25, 2015			

CUSTOMER NOTICE LINEAR TECHNOLOGY HAS MADE A BEST EFFORT TO DESIGN A CIRCUIT THAT MEETS CUSTOMER-SUPPLIED SPECIFICATIONS; HOWEVER, IT REMAINS THE CUSTOMER'S RESPONSIBILITY TO VERIFY PROPER AND RELIABLE OPERATION IN THE ACTUAL APPLICATION. COMPONENT SUBSTITUTION AND PRINTED CIRCUIT BOARD LAYOUT MAY SIGNIFICANTLY AFFECT CIRCUIT PERFORMANCE OR RELIABILITY. CONTACT LINEAR TECHNOLOGY APPLICATIONS ENGINEERING FOR ASSISTANCE.		APPROVALS PCB DES: LT APP ENG: MOLLY Z.	
THIS CIRCUIT IS PROPRIETARY TO LINEAR TECHNOLOGY AND SUPPLIED FOR USE WITH LINEAR TECHNOLOGY PARTS.		SCALE = NONE	

NOTES: UNLESS OTHERWISE SPECIFIED

1. ALL RESISTORS AND CAPACITORS ARE IN OHMS, 0603.

* THE MAX LOAD CURRENT IS REDUCED WHEN THE INPUT VOLTAGE IS LESS THAN 12V. PLEASE SEE DEMO MANUAL FOR DETAILS.

DEMO MANUAL DC2205A

DEMONSTRATION BOARD IMPORTANT NOTICE

Linear Technology Corporation (LTC) provides the enclosed product(s) under the following **AS IS** conditions:

This demonstration board (DEMO BOARD) kit being sold or provided by Linear Technology is intended for use for **ENGINEERING DEVELOPMENT OR EVALUATION PURPOSES ONLY** and is not provided by LTC for commercial use. As such, the DEMO BOARD herein may not be complete in terms of required design-, marketing-, and/or manufacturing-related protective considerations, including but not limited to product safety measures typically found in finished commercial goods. As a prototype, this product does not fall within the scope of the European Union directive on electromagnetic compatibility and therefore may or may not meet the technical requirements of the directive, or other regulations.

If this evaluation kit does not meet the specifications recited in the DEMO BOARD manual the kit may be returned within 30 days from the date of delivery for a full refund. **THE FOREGOING WARRANTY IS THE EXCLUSIVE WARRANTY MADE BY THE SELLER TO BUYER AND IS IN LIEU OF ALL OTHER WARRANTIES, EXPRESSED, IMPLIED, OR STATUTORY, INCLUDING ANY WARRANTY OF MERCHANTABILITY OR FITNESS FOR ANY PARTICULAR PURPOSE. EXCEPT TO THE EXTENT OF THIS INDEMNITY, NEITHER PARTY SHALL BE LIABLE TO THE OTHER FOR ANY INDIRECT, SPECIAL, INCIDENTAL, OR CONSEQUENTIAL DAMAGES.**

The user assumes all responsibility and liability for proper and safe handling of the goods. Further, the user releases LTC from all claims arising from the handling or use of the goods. Due to the open construction of the product, it is the user's responsibility to take any and all appropriate precautions with regard to electrostatic discharge. Also be aware that the products herein may not be regulatory compliant or agency certified (FCC, UL, CE, etc.).

No License is granted under any patent right or other intellectual property whatsoever. **LTC assumes no liability for applications assistance, customer product design, software performance, or infringement of patents or any other intellectual property rights of any kind.**

LTC currently services a variety of customers for products around the world, and therefore this transaction **is not exclusive**.

Please read the DEMO BOARD manual prior to handling the product. Persons handling this product must have electronics training and observe good laboratory practice standards. **Common sense is encouraged.**

This notice contains important safety information about temperatures and voltages. For further safety concerns, please contact a LTC application engineer.

Mailing Address:

Linear Technology
1630 McCarthy Blvd.
Milpitas, CA 95035

Copyright © 2004, Linear Technology Corporation