

LT8390EUF 60V Low EMI Synchronous 4-Switch Buck-Boost Voltage Regulator

DESCRIPTION

Demonstration circuit DC2457A is a 12V, 4A, 4-switch synchronous buck-boost regulator featuring low EMI noise and small footprint. It runs at 400kHz switching frequency. Spread spectrum frequency modulation (SSFM) can be turned on with a simple jumper, reducing EMI. DC2457A also comes with other low EMI features including optimized layout, input and output filters. It passes CISPR 25 class 5 conducted and radiated EMI.

The operating input voltage range of DC2457A is from 4V to 60V. The output voltage and EN/UVLO, are all programmed by resistor dividers. EN/UVLO is set so the circuit will turn off when the input voltage falls below 4V and will turn on when the input voltage rises above 5V.

DC2457A features MOSFETs that complement the 5V gate drive of the LT8390® to achieve high efficiency. 60V MOSFETs are used on the input side of the 4-switch topology while 25V MOSFETs are used on the output side. All those MOSFETs are 3.3mm × 3.3mm footprint. Ceramic capacitors are used at both the circuit input and output because of their small size and high ripple current capability. In addition to ceramic capacitors, there are two aluminum polymer capacitors on the output. The input also has two aluminum polymer capacitors.

The CTRL input is pulled up to the V_{REF} pin through a 0Ω resistor to set the output current limit to its maximum, and an external voltage on CTRL can be used to lower the current limit if the resistor is removed. A capacitor at the SS pin programs soft-start.

The PGOOD is status flag indicates when output voltage is within ±10% of final regulation voltage.

The LT8390's proprietary peak current mode buck-boost architecture ensures DC2457A runs either in discontinuous conduction mode (DCM) or pulse-skipping mode (PSM) without reversed inductor current. Both of them enhance the light load efficiency.

To improve the EMI performance, the LT8390 has spread spectrum frequency modulation. With the SYNC/SPRD pin tied to INTV_{CC}, LT8390 starts to spread its switching frequency ±15% around the programmed oscillator frequency.

There is an EMI filter on the input of DC2457A. There is also a small ferrite bead output filter. These filters, combined with proper board layout and SSFM are effective to help the circuit pass CISPR 25 class 5 conducted and radiated EMI. Please follow the recommended layout and four-layer thickness of DC2457A for low EMI applications.

The demo circuit is designed to be easily reconfigured to many other applications, including the example schematics in the data sheet. Consult the factory for assistance.

The LT8390EUF is available in a thermally enhanced 28-lead (4mm × 5mm) plastic QFN package. The LT8390 data sheet gives a complete description of the part, operation and applications information. The LT8390 data sheet must be read in conjunction with this demo manual to properly use or modify demo circuit DC2457A.

Design files for this circuit board are available at <http://www.linear.com/demo/DC2457A>

LT, LT, LTC, LTM, Linear Technology and the Linear logo are registered trademarks of Linear Technology Corporation. All other trademarks are the property of their respective owners.

DEMO MANUAL DC2457A

PERFORMANCE SUMMARY Specifications are at $T_A = 25^\circ\text{C}$

PARAMETERS	CONDITIONS	MIN	TYP	MAX	UNIT
Input Voltage Range (V_{IN})	$V_{OUT} = 12\text{V}$, $I_{OUT} = 1\text{A}$	4		60	V_{DC}
Output Voltage (V_{OUT})	$R7 = 110\text{k}$, $R8 = 10\text{k}$	11.5	12.0	12.5	V_{DC}
Maximum Output Current*	$5\text{V} \leq V_{IN} \leq 40\text{V}$, $V_{OUT} = 12\text{V}$	4			A
Switching Frequency	$R5 = 100\text{k}$		400		kHz
Input EN Voltage	$R9 = 374\text{k}$, $R10 = 165\text{k}$		5		V_{DC}
Input UVLO Voltage	$R9 = 374\text{k}$, $R10 = 165\text{k}$		4		V_{DC}
Output Current Limit	$R2 = 15\text{m}\Omega$		6.67		A

*The maximum output current is based on 65°C temperature rise of components on demo circuit. The input range mentioned in table is also limited by the same temperature rise. Wider input range and higher output current can be reached if larger copper area or force-air cooling is applied. The maximum output current is also limited by inductor peak current.

QUICK START PROCEDURE

Demonstration circuit DC2457A is easy to set up to evaluate the performance of the LT8390EUF. Refer to Figure 1 for proper measurement equipment setup and follow the procedure below:

NOTE: Make sure that the voltage applied to V_{IN} does not exceed 60V.

1. Set JP1 at NO SSFM/SYFC to disable SSFM, at SSFM ON to enable SSFM, or at EXT SYNC and tie EXT SYNC to external oscillator.
2. Connect the EN/UVLO terminal to ground with a clip-on lead. Connect the power supply (with power off), load, and meters as shown.

3. After all connections are made, turn on the input power and verify that the input voltage is between 4V and 60V.
4. Remove the clip-on lead from EN/UVLO. Verify that the output voltage is 12V.

NOTE: If the output voltage is low, temporarily disconnect the load to make sure that it is not set too high.

5. Once the proper output voltage is established, adjust the input voltage and load within the operating ranges and observe the output voltage regulation, ripple voltage, efficiency and other parameters.

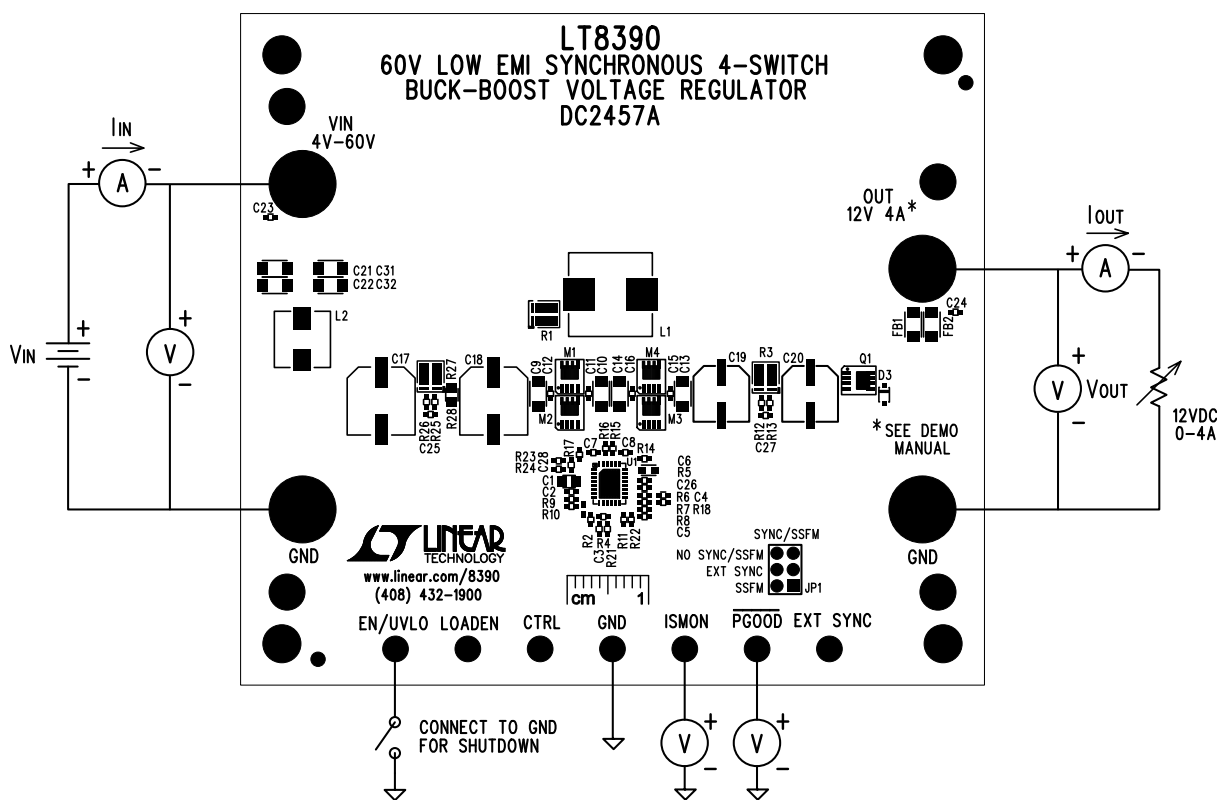

Figure 1. Test Procedure Setup Drawing for DC2457A

TEST RESULTS

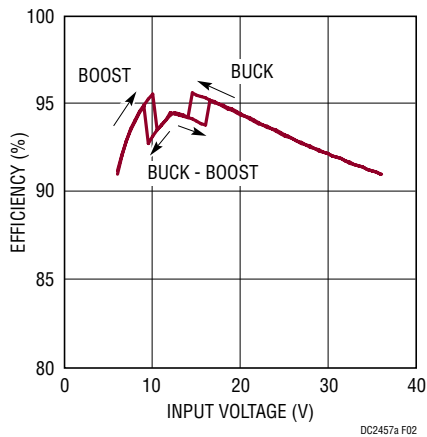

Figure 2. Efficiency vs V_{IN} at Full Load

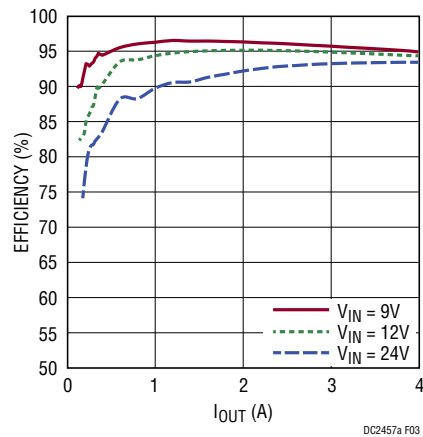

Figure 3. Efficiency vs I_{OUT} at Different V_{IN}

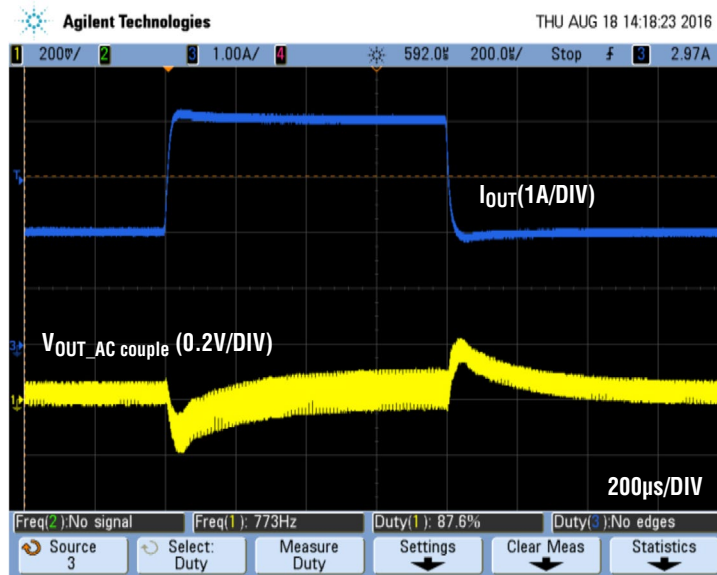

Figure 4. Output Voltage Transient Response, $V_{IN} = 12V$, $V_{OUT} = 12V$, $I_{OUT} = 2A$ to $4A$ to $2A$

TEST RESULTS

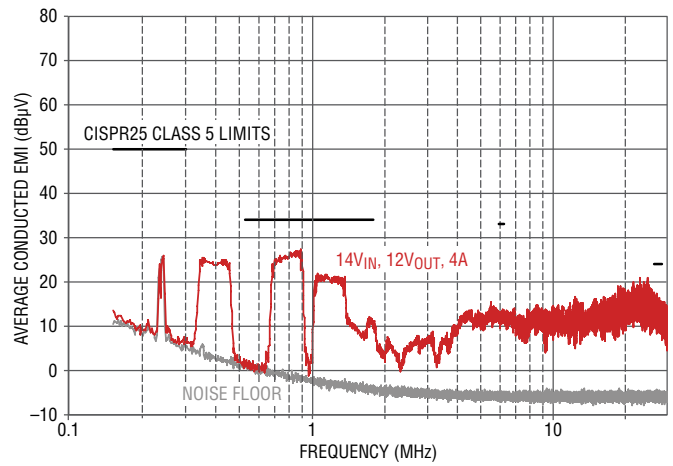
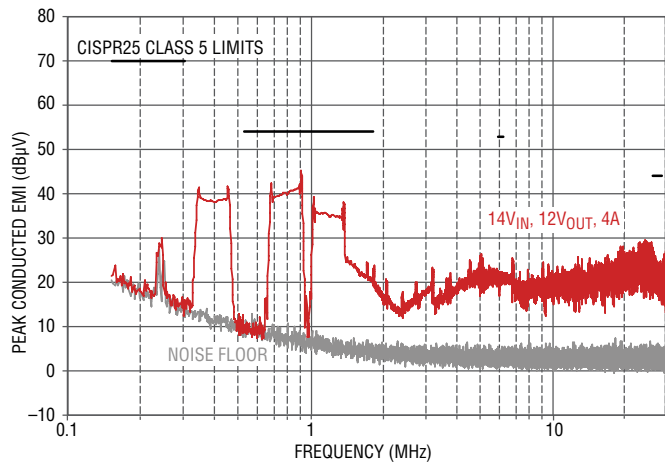

Figure 5. DC2457A Conducted Peak and Average EMI—Passes CISPR 25 Class 5 Limits

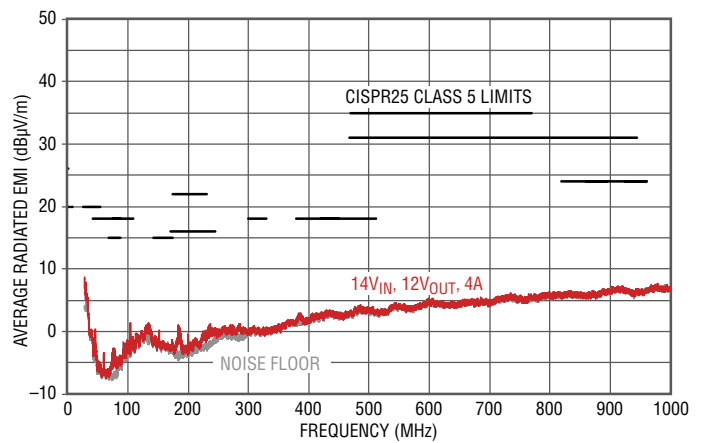
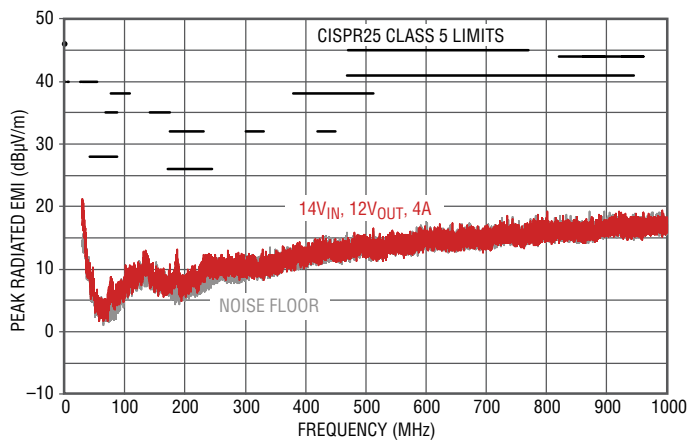

Figure 6. DC2457A Radiated Peak and Average EMI—30MHz to 1GHz—Passes CISPR 25 Class 5 Limits

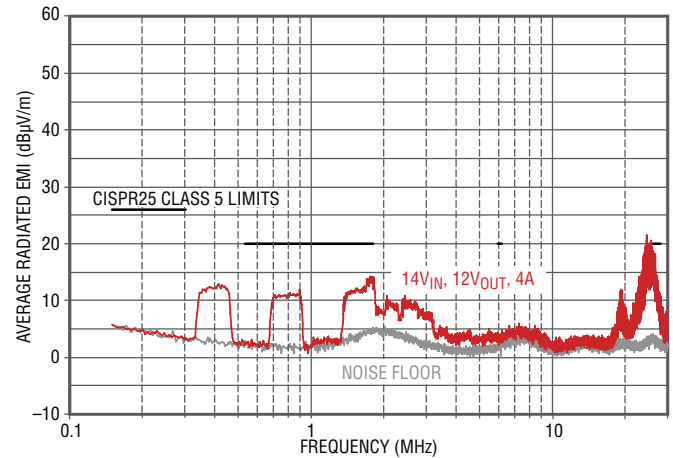
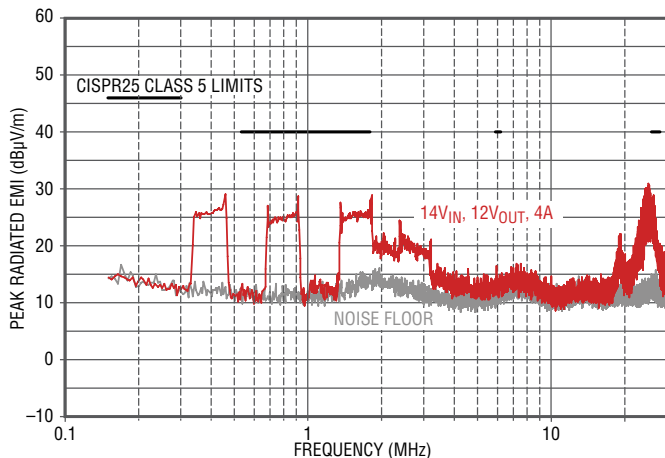

Figure 7. DC2457A Radiated Peak and Average EMI—150kHz to 30MHz—Passes CISPR 25 Class 5 Limits

THERMAL IMAGE

An example thermal image shows the temperature distribution on the DC2457A. The test is done in still air at room temperature (25°C). The highest temp is below 52°C

around buck side MOSFET, at $V_{IN} = 12V$, $V_{OUT} = 12V$, and 4A load current.

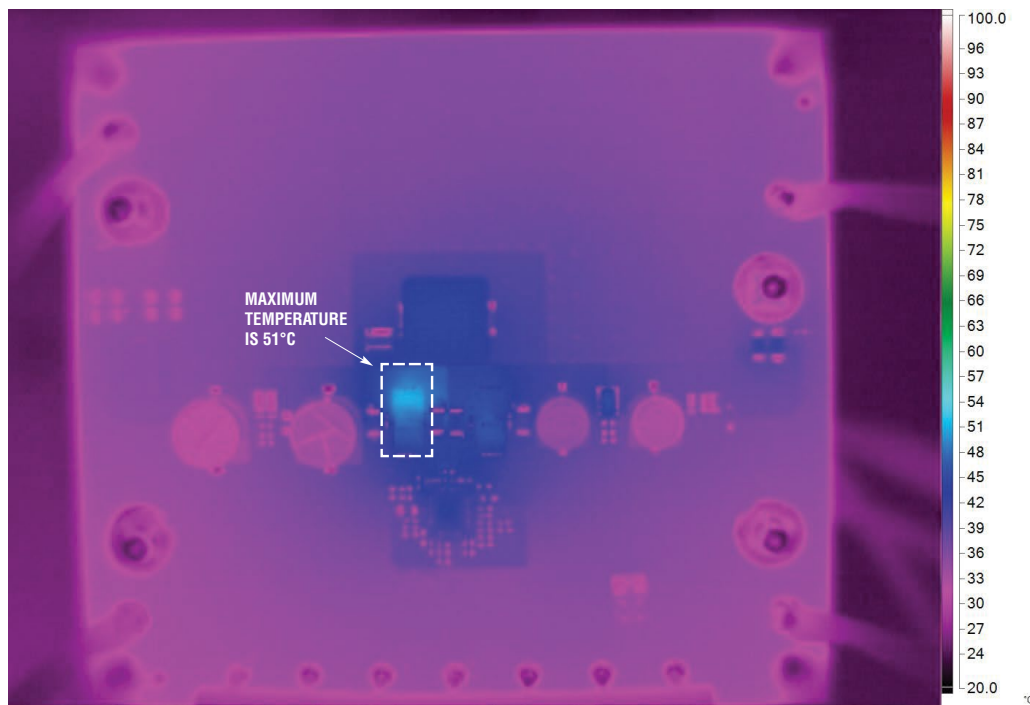

Figure 8. Thermal Performance of DC2457A ($V_{IN} = 12V$, $V_{OUT} = 12V$, $I_{OUT} = 4A$)

PARTS LIST

ITEM	QTY	REFERENCE	PART DESCRIPTION	MANUFACTURER/PART NUMBER
Required Circuit Components				
1	1	C1	CAP, 1 μ F, X7S, 100V, 10%, 0805	MURATA, GRJ21BC72A105KE11L
2	1	C2	CAP, 4.7 μ F, X5R, 10V, 10%, 0402	TDK, C1005X5R1A475K050BC
3	1	C3	CAP, 0.47 μ F, X5R, 16V, 10%, 0402	TDK, C1005X5R1C474K050BC
4	1	C4	CAP, 4.7nF, X7R, 16V, 10%, 0402	MURATA, GRM155R71C472KA01D
5	6	C5, C7, C8, C15, C16, C24	CAP, 0.1 μ F, X7R, 25V, 10%, 0402	AVX, 04023C104KAT2A
6	1	C6	CAP, 1 μ F, X7R, 25V, 10%, 0603	MURATA, GRM188R71E105KA12D
7	4	C9, C10, C21, C22	CAP, CER, 4.7 μ F, X7S, 100V, 20%, 1206	AVX, 12061Z475MAT2A
8	3	C11, C12, C23	CAP, 0.1 μ F, X5R, 100V, 10%, 0402	MURATA, GRM155R62A104KE14D
9	2	C13, C14	CAP, CER, 10 μ F, X7R, 25V, 10%, 1206	MURATA, GRM31CR71E106KA12L
10	2	C17, C18	CAP, ALUM, 22 μ F, 63V, 20%, 8mm \times 10.5mm	SUNCON ELEC, 63HVP22M
11	2	C19, C20	CAP, ALUM, 120 μ F, 25V, 20%, 6.3mm \times 7.7mm	SUNCON ELEC, 16HVHZ120M
12	1	C26	CAP, 100pF, X7R, 16V, 10%, 0402	AVX, 0402YC101KAT2A
13	1	D3	DIODE, SCHOTTKY, 40V, 1A, SOD-323F	NXP, PMEG4010CEJ
14	2	FB1, FB2	BEAD, FERRITE, 1206	WURTH ELEKTRONIK, 742792118
15	1	L1	IND, 4.2 μ H	WURTH, 744325420
16	1	L2	IND, 1.5 μ H	WURTH, 744314150
17	2	M1, M2	XSTR, MOSFET, TSDSON-8	INFINEON, BSZ100N06LS3 G
18	2	M3, M4	XSTR, MOSFET, TSDSON-8	INFINEON, BSZ033NE2LS5
19	1	R1	RES, 0.004 Ω , 1W, 0612	SUSUMU, KRL3216D-M-R004-F-T5
20	1	R3	RES, 0.015 Ω , 1W, 0612	SUSUMU, KRL3216D-M-R015-F-T5
21	2	R5, R11	RES, 100k, 1/16W, 1%, 0402	VISHAY, CRCW0402100KFKED
22	1	R6	RES, 27k, 1/16W, 1%, 0402	VISHAY, CRCW040227K0FKED
23	1	R7	RES, 110k, 1/16W, 1%, 0402	VISHAY, CRCW0402110KFKED
24	1	R8	RES, 10k, 1/16W, 1%, 0402	VISHAY, CRCW040210K0FKED
25	1	R9	RES, 374k, 1/16W, 1%, 0402	VISHAY, CRCW0402374KFKED
26	1	R10	RES, 165k, 1/16W, 1%, 0402	VISHAY, CRCW0402165KFKED
27	4	R14, R15, R16, R17	RES, 10 Ω , 1/16W, 1%, 0402	VISHAY, CRCW040210R0FKED
28	1	U1	IC, VOLTAGE REGULATOR, 28-QFN	LINEAR TECHNOLOGY LT8390EUFDPBF
Additional Demo Board Circuit Components				
29	0	C25, C27, C28 (OPT)	CAP, OPTION, 0402	
30	0	C29 (OPT)	CAP, OPTION, 0805	
31	0	C30 (OPT)	CAP, OPTION, 0805	
32	0	C31, C32 (OPT)	CAP, OPTION, 1206	
33	0	D1, D2 (OPT)	DIODE, OPTION, SOD-123	
34	0	Q1 (OPT)	XSTR, MOSFET, OPTION, PowerPAK 1212-8	
35	3	R2, R4, R18	RES, 0 Ω , 1/16W, 0402	VISHAY, CRCW04020000Z0ED
36	0	R12, R13, R21, R22, R23, R24, R25, R26 (OPT)	RES, OPTION, 0402	
37	0	R19, R20, R28 (OPT)	RES, OPTION, 0805	
38	0	R27 (OPT)	RES, OPTION, 0612	

DEMO MANUAL DC2457A

PARTS LIST

ITEM	QTY	REFERENCE	PART DESCRIPTION	MANUFACTURER/PART NUMBER
Hardware: For Demo Board Only				
39	4	E1, E2, E9, E10	TEST POINT, TURRET, 0.094" MTG HOLE	MILL-MAX, 2501-2-00-80-00-00-07-0
40	7	E3, E4, E5, E6, E7, E8, E11	TEST POINT, TURRET, 0.061" MTG HOLE	MILL-MAX, 2308-2-00-80-00-00-07-0
41	1	JP1	CONN, HEADER, 2X3, 2mm	WURTH ELEKTRONIK, 62000621121
42	1	XJP1	SHUNT, 2mm	WURTH ELEKTRONIK, 60800213421
43	4	J1, J2, J3, J4	CONN, JACK, BANANA, 0.218"	KEYSTONE, 575-4
44	4	MH1 TO MH4	STAND-OFF, NYLON 0.375"	WURTH ELEKTRONIK, 702933000

SCHEMATIC DIAGRAM

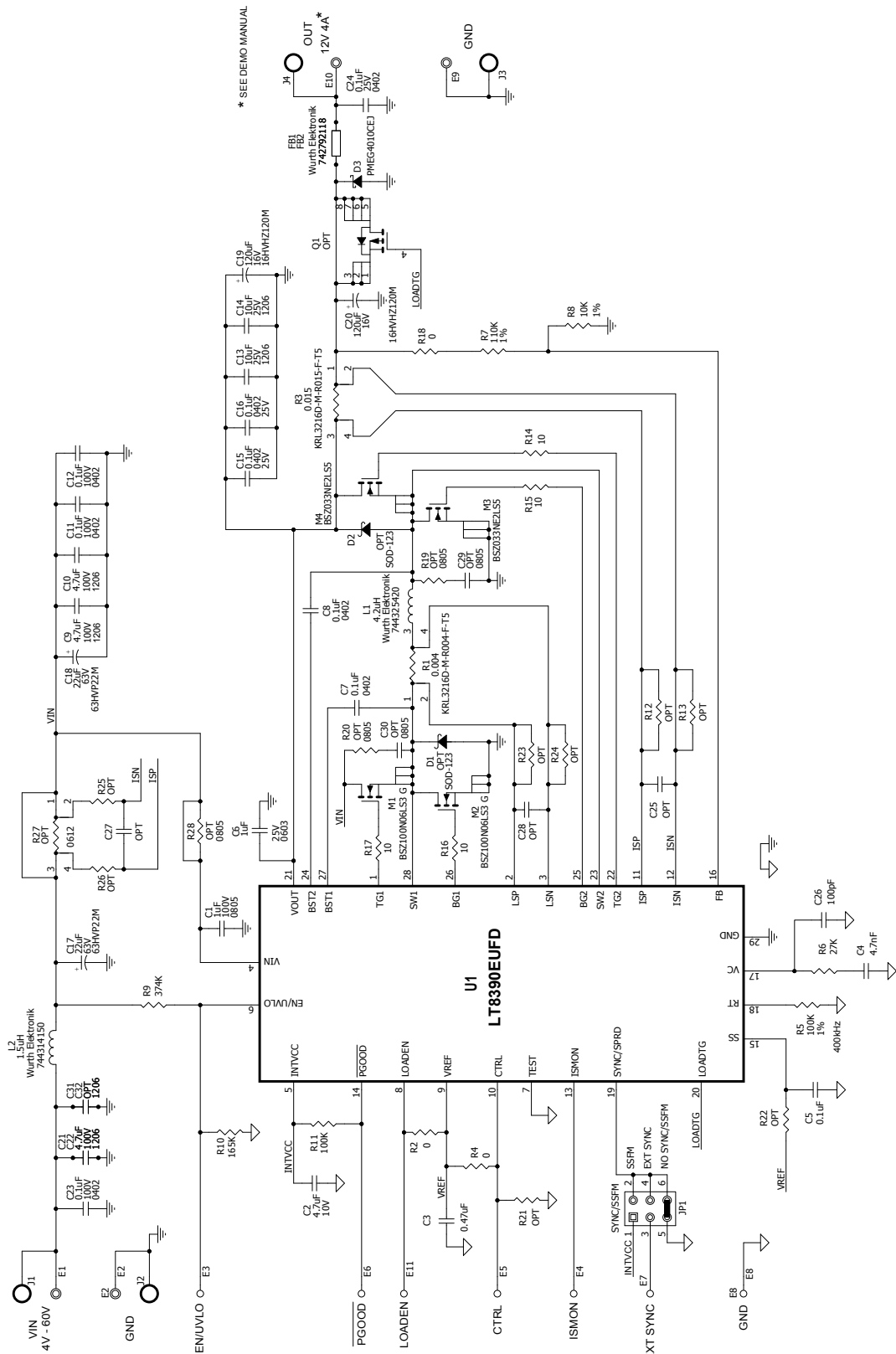

* SEE DEMO MANUAL

NOTE: UNLESS OTHERWISE SPECIFIED
 ALL CAPACITORS ARE 0402.
 ALL RESISTORS ARE 0402.

DEMO MANUAL DC2457A

DEMONSTRATION BOARD IMPORTANT NOTICE

Linear Technology Corporation (LTC) provides the enclosed product(s) under the following **AS IS** conditions:

This demonstration board (DEMO BOARD) kit being sold or provided by Linear Technology is intended for use for **ENGINEERING DEVELOPMENT OR EVALUATION PURPOSES ONLY** and is not provided by LTC for commercial use. As such, the DEMO BOARD herein may not be complete in terms of required design-, marketing-, and/or manufacturing-related protective considerations, including but not limited to product safety measures typically found in finished commercial goods. As a prototype, this product does not fall within the scope of the European Union directive on electromagnetic compatibility and therefore may or may not meet the technical requirements of the directive, or other regulations.

If this evaluation kit does not meet the specifications recited in the DEMO BOARD manual the kit may be returned within 30 days from the date of delivery for a full refund. **THE FOREGOING WARRANTY IS THE EXCLUSIVE WARRANTY MADE BY THE SELLER TO BUYER AND IS IN LIEU OF ALL OTHER WARRANTIES, EXPRESSED, IMPLIED, OR STATUTORY, INCLUDING ANY WARRANTY OF MERCHANTABILITY OR FITNESS FOR ANY PARTICULAR PURPOSE. EXCEPT TO THE EXTENT OF THIS INDEMNITY, NEITHER PARTY SHALL BE LIABLE TO THE OTHER FOR ANY INDIRECT, SPECIAL, INCIDENTAL, OR CONSEQUENTIAL DAMAGES.**

The user assumes all responsibility and liability for proper and safe handling of the goods. Further, the user releases LTC from all claims arising from the handling or use of the goods. Due to the open construction of the product, it is the user's responsibility to take any and all appropriate precautions with regard to electrostatic discharge. Also be aware that the products herein may not be regulatory compliant or agency certified (FCC, UL, CE, etc.).

No License is granted under any patent right or other intellectual property whatsoever. **LTC assumes no liability for applications assistance, customer product design, software performance, or infringement of patents or any other intellectual property rights of any kind.**

LTC currently services a variety of customers for products around the world, and therefore this transaction **is not exclusive**.

Please read the DEMO BOARD manual prior to handling the product. Persons handling this product must have electronics training and observe good laboratory practice standards. **Common sense is encouraged.**

This notice contains important safety information about temperatures and voltages. For further safety concerns, please contact a LTC application engineer.

Mailing Address:

Linear Technology
1630 McCarthy Blvd.
Milpitas, CA 95035

Copyright © 2004, Linear Technology Corporation