

Monolithic Dual Tracking 3.5A Step-Down Switching Regulator

FEATURES

- **Wide Input Range:**
 - Operation from 3V to 36V
 - OVLO Protects Circuit Through 60V Transients
- **Independent Supply, Shutdown, Soft-Start, Programmable Current Limit and Programmable Power Good for Each 3.5A Regulator**
- **Die Temperature Monitor**
- **Adjustable/Synchronizable Fixed Frequency Operation from 250kHz to 2.25MHz with Synchronized Clock Output**
- **Independent Synchronized Switching Frequencies Optimize Component Size**
- **Antiphase Switching**
- **Outputs Can Be Paralleled**
- Flexible Output Voltage Tracking
- Enhanced Short-Circuit Protection
- Low Dropout: 95% Maximum Duty Cycle
- 5mm × 5mm QFN Package

APPLICATIONS

- Automotive Supplies
- Distributed Supply Regulation

DESCRIPTION

The LT[®]3692 is a dual current mode PWM step-down DC/DC converter with two internal 3.8A switches. Independent input voltage, shutdown, feedback, soft-start, current limit and comparator pins for each channel simplify complex power supply tracking and sequencing requirements.

To optimize efficiency and component size, both converters have a programmable maximum current limit and are synchronized to either a common external clock input, or a resistor settable fixed 250kHz to 2.25MHz internal oscillator. A frequency divider is provided for channel 1 to further optimize component size. At all frequencies, a 180° phase relationship between channels is maintained, reducing voltage ripple and component size. A clock output is available for synchronizing multiple regulators.

Minimum input to output voltage ratios are improved by allowing the switch to stay on through multiple clock cycles only switching off when the boost capacitor needs recharging. Independent channel operation can be programmed using the SHDN pin. Disabling both converters reduces the total quiescent to <10 μ A.

LT, LT, LTC, LTM, Burst Mode, Linear Technology and the Linear logo are registered trademarks of Linear Technology Corporation. All other trademarks are the property of their respective owners.

TYPICAL APPLICATION

Dual 1.8V/3.5A and 5V/3.5A Step-Down Converter

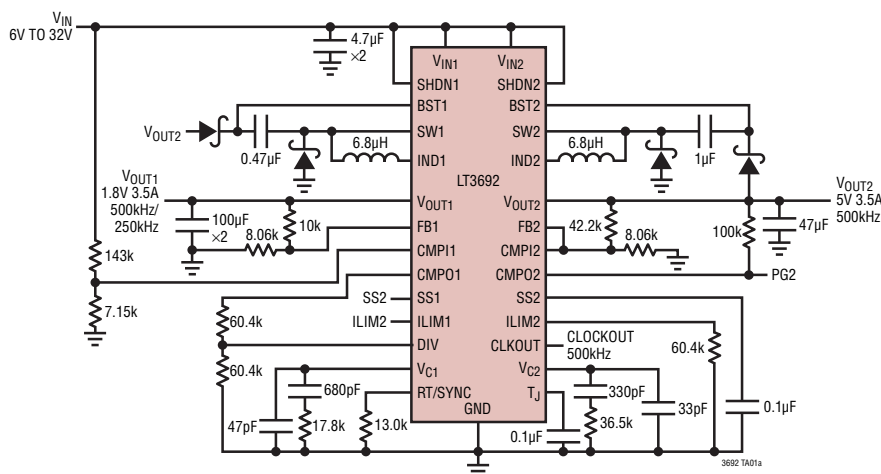

Independent Synchronized Switching Frequencies
Extend Full Frequency Input Range

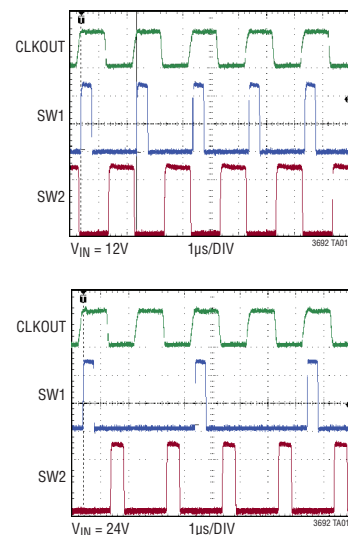

ABSOLUTE MAXIMUM RATINGS

(Note 1)

$V_{IN1/2}$, SHDN1/2, CMP01/2	40V/−0.3V
$V_{IN1/2}$ Transient (Note 2)	60V/−0.3V
SW1/2	$V_{IN1/2}$
BST1/2	60V/−0.3V
BST1/2 Pin Above SW1/2	25V
IND1/2, $V_{OUT1/2}$	40V/−0.3V, 7A
FB1/2, CMPI1/2, SS1/2	5V
RT/SYNC	5V
DIV, ILIM1/2	2.5V
$V_{C1/2}$, T_J	±100 μ A
Operating Junction Temperature Range (Note 3)	
LT3692EUH	−40°C to 125°C
LT3692IUH	−40°C to 125°C
Storage Temperature Range	−65°C to 150°C

PIN CONFIGURATION

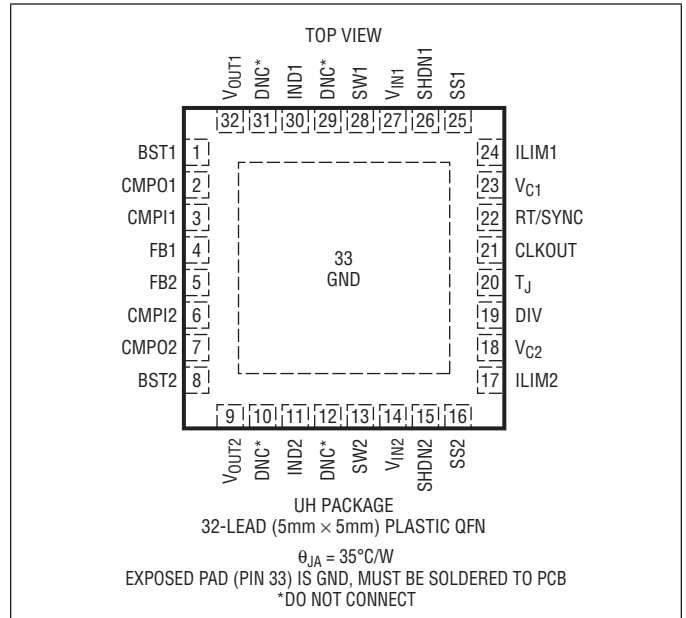

ORDER INFORMATION

LEAD FREE FINISH	TAPE AND REEL	PART MARKING*	PACKAGE DESCRIPTION	TEMPERATURE RANGE
LT3692EUH#PBF	LT3692EUH#TRPBF	3692	32-Lead (5mm × 5mm) Plastic QFN	−40°C to 125°C
LT3692IUH#PBF	LT3692IUH#TRPBF	3692	32-Lead (5mm × 5mm) Plastic QFN	−40°C to 125°C

Consult LTC Marketing for parts specified with wider operating temperature ranges. *The temperature grade is identified by a label on the shipping container. Consult LTC Marketing for information on non-standard lead based finish parts.

For more information on lead free part marking, go to: <http://www.linear.com/leadfree/>

For more information on tape and reel specifications, go to: <http://www.linear.com/tapeandreel/>

ELECTRICAL CHARACTERISTICS

The ● denotes the specifications which apply over the full operating temperature range, otherwise specifications are at $T_A = 25^\circ\text{C}$. $V_{IN1/2} = 15\text{V}$ unless otherwise specified. (Note 3)

PARAMETER	CONDITIONS	MIN	TYP	MAX	UNITS
SHDN Voltage Threshold Ch 1/2 (Note 4)		● 1.24	1.32	1.4	V
SHDN Input Current Ch 1/2	$V_{SHDN} = 1.3\text{V}$		1.5	5	μA
V_{IN1} Undervoltage Lockout (Note 5)	$V_{FB1/2} = 0\text{V}$, $V_{VOUT1/2} = 0\text{V}$, $V_{IND1/2} = 0\text{V}$	2.5	2.8	3.1	V
V_{IN} Overvoltage Lockout Ch 1/2 (Note 6)		36	38	41	V
V_{IN1} Shutdown Current	$V_{SHDN} = 0\text{V}$	●	6	10	μA
V_{IN2} Shutdown Current	$V_{SHDN} = 0\text{V}$	●	0	2	μA
V_{IN1} Quiescent Current	$V_{FB1/2} = 0.9\text{V}$	3	4	5	mA
V_{IN2} Quiescent Current	$V_{FB1/2} = 0.9\text{V}$	400	630	1000	μA
Feedback Voltage Ch 1/2	$V_{VC1/2} = 1\text{V}$	● 790	806	822	mV

ELECTRICAL CHARACTERISTICS The ● denotes the specifications which apply over the full operating temperature range, otherwise specifications are at $T_A = 25^\circ\text{C}$. $V_{\text{VIN}1/2} = 15\text{V}$ unless otherwise specified. (Note 3)

PARAMETER	CONDITIONS		MIN	TYP	MAX	UNITS
Feedback Voltage Regulation	$V_{\text{VIN}1/2} = 3$ to 40V , $V_{\text{VC}1/2} = 0.6$ to 1.6V	●	780	806	830	mV
Feedback Voltage Offset Ch 1 to Ch 2	$V_{\text{VC}1/2} = 1\text{V}$	●	-12	0	12	mV
Feedback Bias Current Ch 1/2	$V_{\text{FB}1/2} = 0.8\text{V}$, $V_{\text{VC}1/2} = 1\text{V}$	●	0	85	200	nA
T_J Output Voltage (Note 7)	$T_J = 25^\circ\text{C}$, $I_{TJ} = 25\mu\text{A}$, Temperature = 25°C $I_{TJ} = 25\mu\text{A}$, Temperature = 125°C $I_{TJ} = 25\mu\text{A}$, Temperature = -40°C			250 1.23 -380		mV V mV
T_J Error		●	-60	0	60	mV
Error Amp g_m Ch 1/2	$V_{\text{VC}1/2} = 1\text{V}$, $I_{\text{VC}1/2} = \pm 5\mu\text{A}$		350	400	450	μMho
Error Amp Source Current Ch 1/2	$V_{\text{FB}1/2} = 0.6\text{V}$, $V_{\text{VC}1/2} = 1\text{V}$		19	25	31	μA
Error Amp Sink Current Ch 1/2	$V_{\text{FB}1/2} = 1\text{V}$, $V_{\text{VC}1/2} = 1\text{V}$		22	28	34	μA
Error Amp High Clamp Ch 1/2	$V_{\text{FB}1/2} = 0.6\text{V}$		1.7	1.9	2.1	V
Error Amp Switching Threshold Ch 1/2	$V_{\text{FB}1/2} = 0.6\text{V}$		0.75	0.9	1.05	V
Soft-Start Source Current Ch 1/2	$V_{\text{FB}1/2} = 0.9\text{V}$, $V_{\text{SS}1/2} = 0.05\text{V}$	●	9.5	12	14.5	μA
Soft-Start V_{OH} Ch 1/2	$V_{\text{FB}1/2} = 0.9\text{V}$		1.9	2.15	2.4	V
Soft-Start Sink Current Ch 1/2	$V_{\text{FB}1/2} = 0.4\text{V}$, $V_{\text{SS}1/2} = 2\text{V}$		0.9	1.4	2	mA
Soft-Start V_{OL} Ch 1/2	$V_{\text{FB}1/2} = 0\text{V}$		120	160	200	mV
Soft-Start to Feedback Offset Ch 1/2	$V_{\text{VC}1/2} = 1\text{V}$, $V_{\text{SS}1/2} = 0.4\text{V}$	●	-12	0	12	mV
Soft-Start Sink Current Ch 1/2 POR	$V_{\text{FB}1/2} = 0\text{V}$, $V_{\text{SS}1/2} = 0.12\text{V}$ (Note 8)		150	400	600	μA
Soft-Start POR Threshold Ch 1/2	$V_{\text{FB}1/2} = 0\text{V}$ (Note 8)		70	90	120	mV
Soft-Start SW Disable Ch 1/2	$V_{\text{FB}1/2} = 0\text{V}$ (Note 8)		95	115	150	mV
CMPI Bias Current Ch 1/2	$V_{\text{CMPI}1/2} = 0.8\text{V}$		-100	0	100	nA
CMPO Leakage Ch 1/2	$V_{\text{CMPI}1/2} = 0.8\text{V}$, $V_{\text{CMPO}1/2} = 25\text{V}$,			70	200	nA
CMPI Threshold Ch 1/2	$V_{\text{CMPI}1/2}$ Rising	●	700	720	740	mV
CMPI Threshold Ch 1/2 of $V_{\text{FB}1/2}$	$V_{\text{CMPI}1/2}$ Rising (Note 9)		86	90	94	%
CMPI Hysteresis Ch 1/2	$V_{\text{CMPI}1/2}$		35	60	85	mV
CMPO Sink Current Ch 1/2	$V_{\text{CMPI}1/2} = 0.6\text{V}$, $V_{\text{CMPO}1/2} = 0.2\text{V}$,		200	300	400	μA
RT/SYNC Reference Current	$V_{\text{FB}1/2} = 0.9\text{V}$, $V_{\text{RT/SYNC}} = 0.5\text{V}$	●	11.3	12	12.7	μA
Minimum Switching Frequency	$R_{\text{RT/SYNC}} = 0\Omega$		50	110	150	kHz
Switching Frequency	$R_{\text{RT/SYNC}} = 28\text{k}$		925	1	1075	MHz
Maximum Switching Frequency	$R_{\text{RT/SYNC}} = 100\text{k}$		2.25	2.5	2.75	MHz
Switching Phase Angle Ch 1 \geq Ch 2				185		Deg
DIV Reference Current	$V_{\text{FB}1/2} = 0.9\text{V}$, $V_{\text{DIV}} = 0.5\text{V}$	●	10.5	12	13.5	μA
CH1 DIV 2 Threshold	$R_{\text{RT/SYNC}} = 0\text{V}$		0.51	0.58	0.61	V
CH1 DIV 4 Threshold	$R_{\text{RT/SYNC}} = 0\text{V}$		0.9	1.05	1.1	V
CH1 DIV 8 Threshold	$R_{\text{RT/SYNC}} = 0\text{V}$		1.45	1.55		V
CLKOUT V_{OL}	$I_{\text{CLKOUT}} = -100\mu\text{A}$			0.25		V
CLKOUT V_{OH}	$I_{\text{CLKOUT}} = 100\mu\text{A}$			2		V
CLKOUT to SW10N Delay (t_{DCLKOSW1})	CLKOUT Rising			60		ns
CLKOUT to SW20N Delay (t_{DCLKOSW2})	CLKOUT Falling			30		ns

ELECTRICAL CHARACTERISTICS

The ● denotes the specifications which apply over the full operating temperature range, otherwise specifications are at $T_A = 25^\circ\text{C}$. $V_{IN1/2} = 15\text{V}$ unless otherwise specified. (Note 3)

PARAMETER	CONDITIONS	MIN	TYP	MAX	UNITS
RT/SYNC to CLKOUT Delay ($t_{DRTSYNCH}$)	$V_{RT/SYNC} = 0\text{V}$ to 2V Rising Edge		300		ns
RT/SYNC to CLKOUT Delay ($t_{DRTSYNCL}$)	$V_{RT/SYNC} = 2\text{V}$ to 0V Falling Edge		150		ns
SYNC Frequency Range		250		2000	kHz
SYNC Phase Angle Ch 1 to Ch 2	SYNC Frequency = 250kHz		180		Deg
Minimum Switch On-Time Ch 1/2			180		ns
Minimum Switch Off-Time Ch 1/2			200		ns
Minimum Boost for 100% DC Ch 1/2 (Note 10)		1.4	1.8	2.2	V
IND + V_{OUT} Current Ch 1/2	$V_{VOUT1/2} = 0\text{V}$ $V_{VOUT1/2} = 5\text{V}$		1.5 0.5	5 5	μA μA
ILIM1/2 Reference Current	$V_{FB1/2} = 0.9\text{V}$, $V_{ILIM} = 0.4\text{V}$	● 10	12	14	μA
IND to V_{OUT} Maximum Current Ch 1/2	$V_{ILIM1/2} = 0\text{V}$, $V_{VOUT} = 1\text{V}$ (Note 11)	1	1.8	2.6	A
	$V_{ILIM1/2} = 0\text{V}$, $V_{VOUT} = 5\text{V}$ (Note 11)	1.25	2	2.75	A
	$V_{ILIM1/2} = 0.5\text{V}$, $V_{VOUT} = 1\text{V}$ (Note 11)	1.6	2.6	3.6	A
	$V_{ILIM1/2} = 0.5\text{V}$, $V_{VOUT} = 5\text{V}$ (Note 11)	1.8	2.8	3.8	A
	$V_{ILIM1/2} = 1.5\text{V}$, $V_{VOUT} = 1\text{V}$ (Note 11)	● 3.8	4.8	5.8	A
	$V_{ILIM1/2} = 1.5\text{V}$, $V_{VOUT} = 5\text{V}$ (Note 11)	● 3.8	4.8	5.8	A
Switch Leakage Current Ch 1/2	$V_{SW1/2} = 0\text{V}$	●	1	5.0	μA
Switch Saturation Voltage Ch 1/2	$I_{SW1/2} = 500\text{mA}$, $V_{BST1/2} = 18\text{V}$ $I_{SW1/2} = 3\text{A}$, $V_{BST1/2} = 18\text{V}$		100		mV
			300		mV
Boost Current Ch 1/2	$I_{SW1/2} = 500\text{mA}$, $V_{BST1/2} = 18\text{V}$ $I_{SW1/2} = 3\text{A}$, $V_{BST1/2} = 18\text{V}$	9	13	17	mA
		40	55	70	mA
Minimum Boost Voltage Ch1/2 (Note 12)	$I_{SW1/2} = 3\text{A}$, $V_{BST1/2} = 18\text{V}$	1.75	2.0	2.5	V

Note 1: Stresses beyond those listed under Absolute Maximum Ratings may cause permanent damage to the device. Exposure to any Absolute Maximum Rating condition for extended periods may affect device reliability and lifetime.

Note 2: Absolute Maximum Voltage at $V_{IN1/2}$ and SHDN1/2 pins is 60V for nonrepetitive 1 second transients and 40V for continuous operation.

Note 3: The LT3692EUH is guaranteed to meet performance specifications from 0°C to 125°C junction temperature. Specifications over the -40°C to 125°C operating junction temperature range are assured by design, characterization and correlation with statistical process controls. The LT3692IUH is guaranteed over the full -40°C to 125°C operating junction temperature range.

Note 4: The SHDN pins can be connected to V_{IN} or driven by a logic-level source with a series current limiting resistor.

Note 5: V_{IN} undervoltage lockout is defined as the voltage which the V_{IN} pin must exceed for operation. The threshold guarantees that internal bias lines are regulated and switching frequency is constant. Actual minimum input voltage to maintain a regulated output will depend upon output voltage and load current. See Applications Information.

Note 6: V_{IN} overvoltage lockout is defined as the voltage when exceeded halts converter operation. See Applications Information.

Note 7: The T_J output voltage represents the temperature at the center of the die while dissipating quiescent power. Due to switch power dissipation and temperature gradients across the die, the T_J output voltage measurement does not guarantee that absolute maximum junction temperature will not be exceeded.

Note 8: An internal power on reset (POR) latch is set on the positive transition of the SHDN1/2 pin through its threshold, thermal shutdown or overvoltage lockout. The output of the latch activates current sources on each SS pin which typically sink $400\mu\text{A}$ and discharge the SS capacitor. The latch is reset when both SS pins are driven below the soft-start POR threshold or the SHDN pin is taken below its threshold.

Note 9: The threshold is expressed as a percentage of the feedback reference voltage for the channel.

Note 10: To enhance dropout operation, the output switch will be turned off for the minimum off-time only when the voltage across the boost capacitor drops below the minimum boost for 100% duty cycle threshold.

Note 11: The IND to V_{OUT} maximum current is defined as the value of current flowing from the IND pin to the V_{OUT} pin which resets the switch latch when the V_C pin is at its high clamp.

Note 12: This is the minimum voltage across the boost capacitor needed to guarantee full saturation of the internal power switch.

TYPICAL PERFORMANCE CHARACTERISTICS

Shutdown Threshold and Minimum Input Voltage vs Temperature

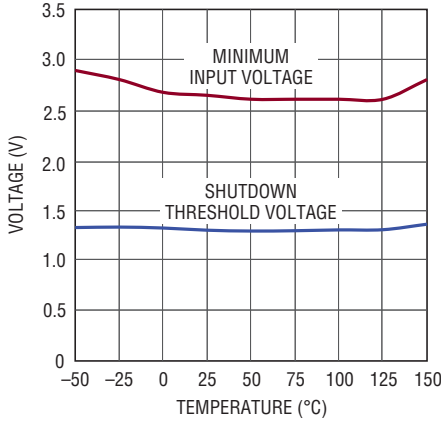

3692 G01

Shutdown Pin Input Current vs Temperature

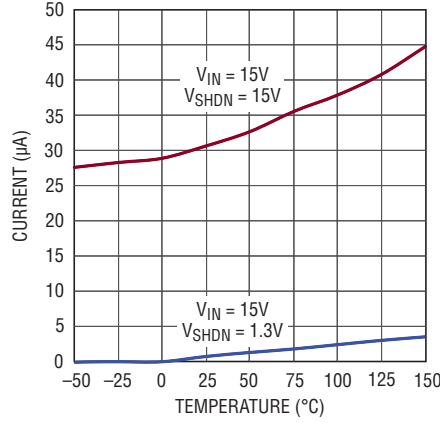

3692 G02

V_{IN} Overvoltage Threshold vs Temperature

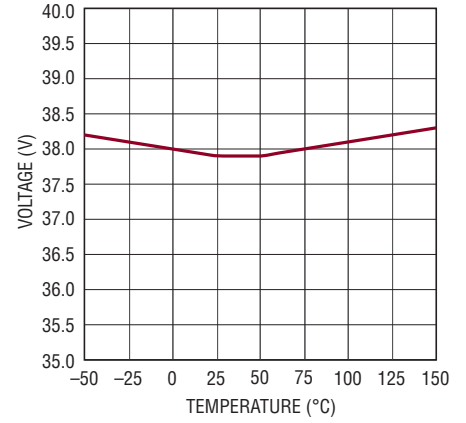

3692 G04

Shutdown Quiescent Current vs Temperature

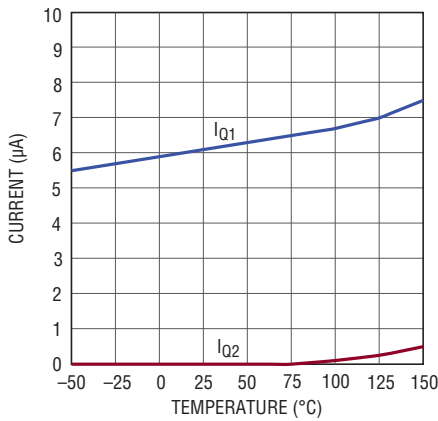

3692 G05

FB Voltage and CH1-CH2 FB Offset vs Temperature

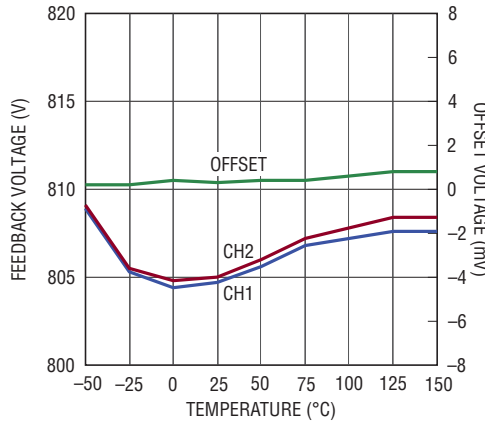

3692 G06

T_J Output Voltage vs Temperature

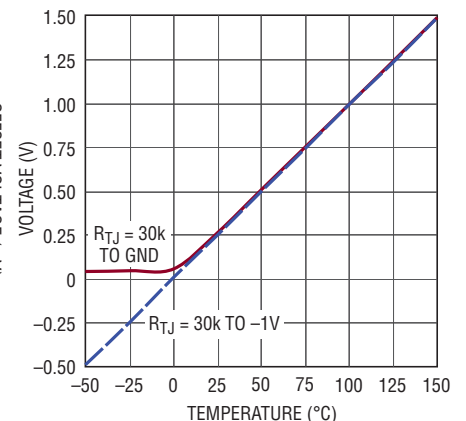

3692 G07

Error Amplifier Transconductance vs Temperature

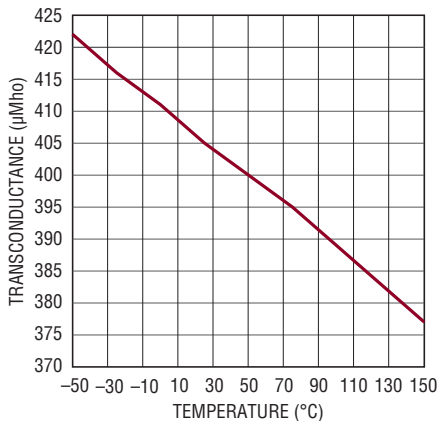

3692 G08

Soft-Start-to-Feedback Offset vs Temperature

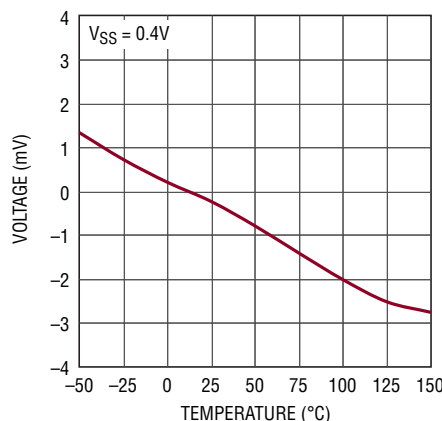

3692 G09

Comparator Thresholds vs Temperature

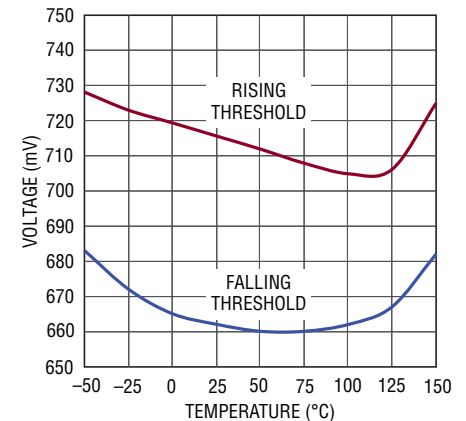

3692 G10

TYPICAL PERFORMANCE CHARACTERISTICS

Comparator Sink Current vs Temperature

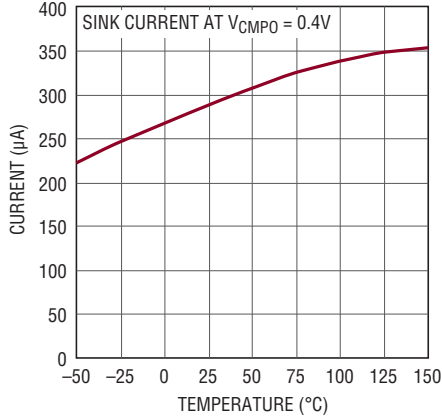

3692 G11

Switching Frequency vs Temperature

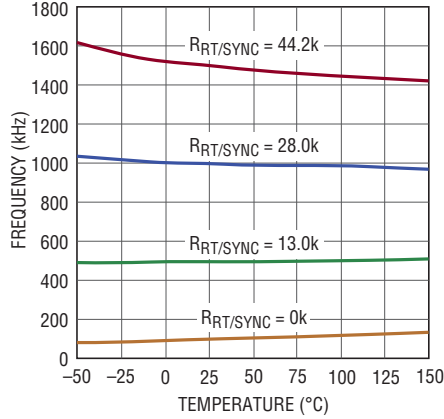

3692 G12

Switching Phase vs Temperature

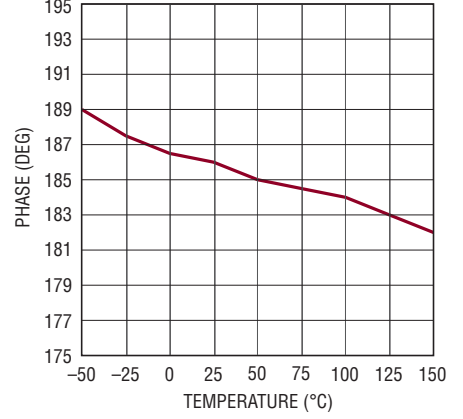

3692 G13

CLKOUT-to-SW1 Delay vs Temperature

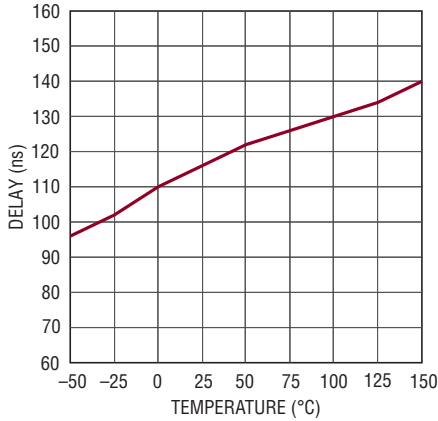

3692 G14

RT/SYNC-to-CLKOUT and SW1 Delay vs Temperature

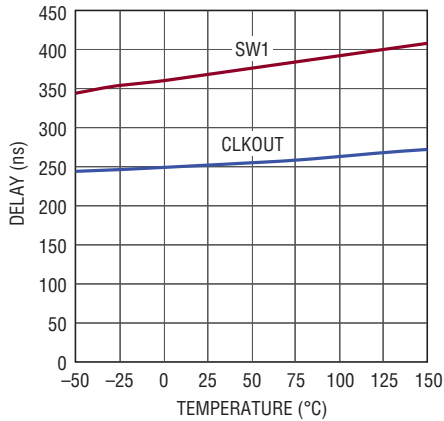

3695 G15

Synchronization Duty Cycles vs Temperature

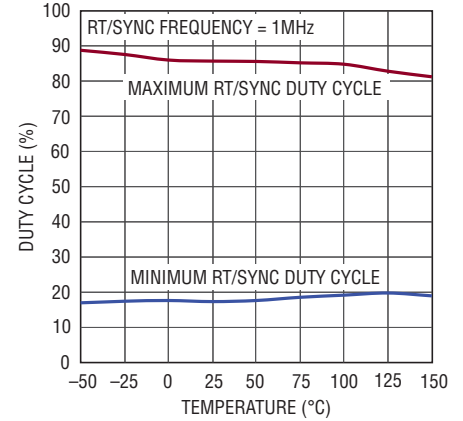

3692 G16

DIV Voltage Threshold vs Temperature

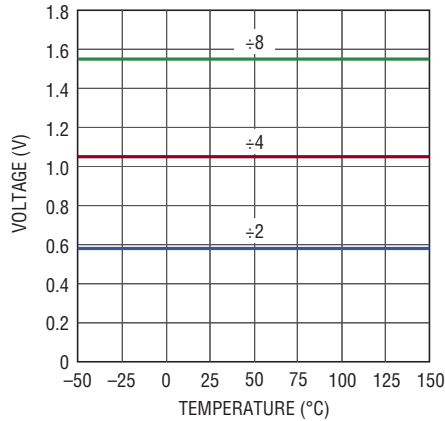

3695 G17

Switch Saturation Voltage vs Temperature

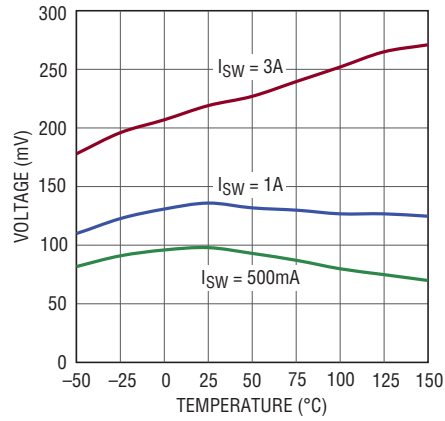

3692 G18

TYPICAL PERFORMANCE CHARACTERISTICS

Boost Current vs Temperature

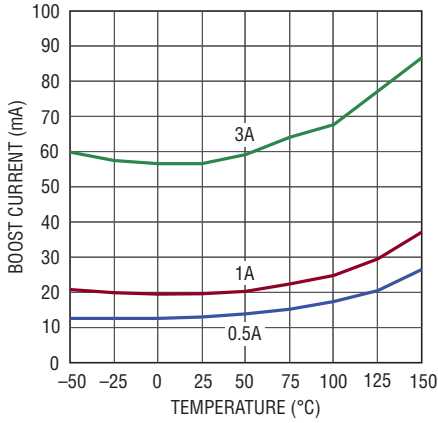

3692 G19

Switch Peak Current vs Temperature

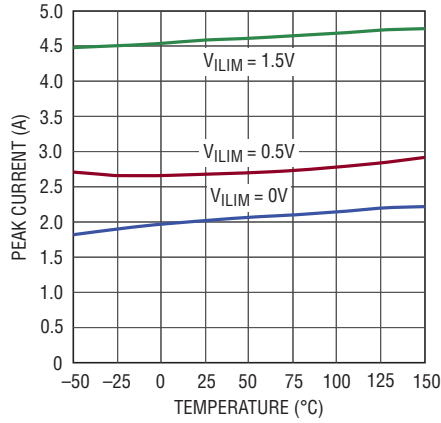

3692 G20

Minimum Boost Voltage vs Temperature

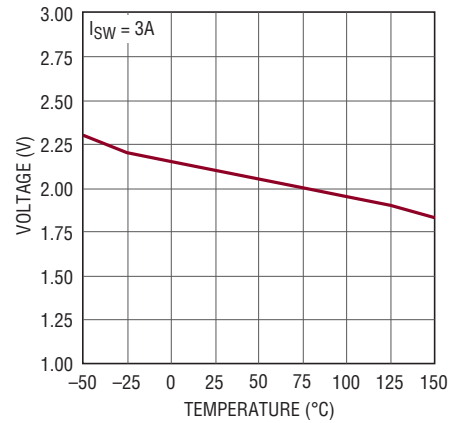

3692 G21

Switching Frequency vs RT/SYNC Resistance

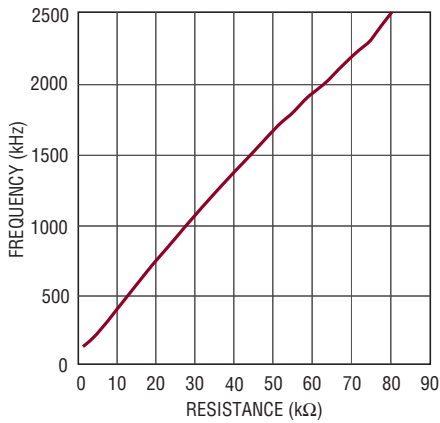

3692 G22

Efficiency, T_J vs Load Current

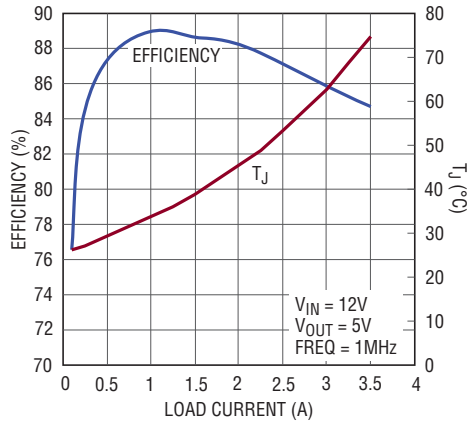

3692 G23

Efficiency, T_J vs Load Current

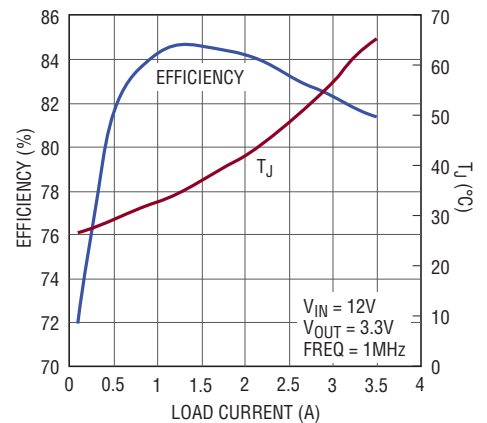

3692 G24

Efficiency, T_J vs Load Current

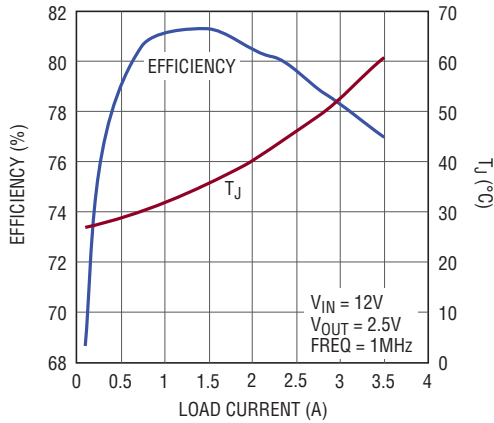

3692 G25

Efficiency, T_J vs Load Current

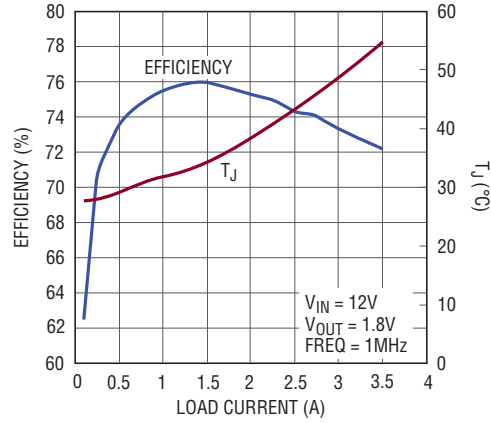

3692 G26

PIN FUNCTIONS

BST1/2: The BST pin provides a higher than V_{IN} base drive to the power NPN to ensure a low switch drop. If the voltage between the BST pin and the V_{IN} pin is less than the voltage required to fully turn on the power NPN, the power switch is turned off to recharge the BST capacitor.

CMPI1/2: The CMPI pin is an input to a comparator with a threshold of 720mV and 60mV of hysteresis. Connecting the CMPI pin to the FB pin will generate a power good signal when the output is within 90% of its regulated value.

CMPO1/2: The CMPO pin is an open-collector output that sinks current when the CMPI pin falls below its threshold. For a typical input voltage above 2.8V, its output state remains true, although during shutdown, V_{IN1} undervoltage lockout or thermal shutdown, its current sink capability is reduced. The COMPO pins can be left open circuit or tied together to form a single power good signal.

DIV: The voltage present at the DIV pin determines the ratio of channel 1 frequency to the master clock frequency set by the RT/SYNC pin. The DIV pin is driven by an internal current source with a typical value of 12 μ A which allows a single resistor from the DIV pin to ground to set the DIV voltage and resulting channel 1 frequency divider. Ratios of 1, 2, 4 and 8 are available. See the Applications Information section for more information.

DNC: Do Not Connect.

GND: The exposed pad pin is the **only ground connection** for the device. The exposed pad should be soldered to a large copper area to reduce thermal resistance. The GND pin is common to both channels and also serves as small-signal ground. For ideal operation all small-signal ground paths should connect to the GND pin at a single point avoiding any high current ground returns.

FB1/2: The FB pin is the negative input to the error amplifier. The output switches to regulate this pin to 806mV with respect to the exposed ground pad. Bias current flows out of the FB pin.

ILIM1/2: The voltage present at the ILIM pin determines the peak inductor current for the channel. The ILIM pin is driven by an internal current source with a typical value of 12 μ A. A resistor from the ILIM pin to ground sets the ILIM voltage. The maximum current limit range is 4.8A to 2A when the ILIM voltages are 1.5V and 0V respectively.

IND1/2: The IND pin is the input to the internal sense resistor that measures current flowing in the inductor. When the current in the resistor exceeds the current dictated by the V_C pin, the SW latch is held in reset, disabling the output switch. Bias current flows out of the IND pin.

RT/SYNC: The voltage present at the RT/SYNC pin determines the constant switching frequency. The RT/SYNC pin is driven by an internal current source with a typical value of 12 μ A which allows a single resistor from the RT/SYNC pin to ground to set the RT/SYNC voltage and resulting switching frequency. Minimum switching frequency is typically 110kHz when $V_{RT/SYNC}$ is 0V and maximum switching frequency is typically 2.5MHz when $V_{RT/SYNC}$ is above 950mV.

Driving the RT/SYNC pin with an external clock signal will synchronize the switch to the applied frequency. Synchronization occurs on the rising edge of the clock signal after the clock signal is detected. Each rising clock edge initiates an oscillator ramp reset. A gain control loop servos the oscillator charging current to maintain constant oscillator amplitude. Hence, the slope compensation and channel phase relationship remain unchanged. If the clock signal is removed, the oscillator reverts to resistor mode after the synchronization detection circuitry times out. The clock source impedance should be set such that the current out of the RT/SYNC pin in resistor mode generates a frequency roughly equivalent to the synchronization frequency. See the Applications Information section for more information.

PIN FUNCTIONS

SHDN1/2: The shutdown pin is used to control each channel's operation. In addition to controlling channel 1, the SHDN1 pin also activates control circuitry for both channels and must be present for channel 2 to operate. When SHDN1 is below its threshold, quiescent current is reduced to a typical value of 6 μ A. If the shutdown features are not used, the SHDN pin can be tied to V_{IN} . If SHDN pin is driven by a logic signal, a series resistor is required. See Applications Information.

SS1/2: Current flowing out the SS pin into an external capacitor defines the rise time of the output voltage. When the SS pin is lower than the 0.8V reference, the feedback is regulated to the SS voltage. When the SS pin exceeds the reference voltage, the output will regulate the FB pin voltage to 0.8V and the SS pin will continue to rise until its clamp voltage. During an output overload, the V_C pin is driven above the maximum switch current level activating its voltage clamp. When the V_C clamp is activated, the SS pin is discharged until the output reaches a regulation point that the maximum output current can maintain. When the overload condition is removed, the output soft starts from that voltage. In the case of a SHDN or thermal shutdown event, a power on reset latch ensures the capacitors on both channels are fully discharged before either is released. Connecting both SS pins together ensures the outputs track together.

CLKOUT: The CLKOUT pin generates a square wave of 0V to 2.5V which is synchronized to the internal oscillator. If the switching frequency is set by an external resistor the resultant clock duty cycle will be 50%. If the RT/SYNC pin is driven by an external clock source, the resultant CLKOUT duty cycle will mirror the external source.

SW1/2: The SW pin is the emitter of the internal power NPN. At switch off, the inductor will drive this pin below ground with a high dV/dt. An external Schottky catch diode to ground, close to the SW pin and respective V_{IN} decoupling capacitor's ground, must be used to prevent this pin from excessive negative voltages.

T_J : The T_J pin outputs a voltage proportional to junction temperature. The pin is 250mV for 25°C and has a slope of 10mV/°C. See the Applications Information section for more information.

V_C 1/2: The V_C pin is the output of the error amplifier and the input to the peak switch current comparator. It is normally used for frequency compensation, but can also be used as a current clamp or control loop override. If the error amplifier drives V_C above the maximum switch current level, a voltage clamp activates. This indicates that the output is overloaded and current is pulled from the SS pin reducing the regulation point.

V_{IN1} : The V_{IN1} pin powers the internal control circuitry for both channels and is monitored by overvoltage/undervoltage lockout comparators. The V_{IN1} pin is also connected to the collector of channel 1's on-chip power NPN switch. The V_{IN1} pin has high dI/dt edges and must be decoupled to ground close to the pin of the device.

V_{IN2} : The V_{IN2} pin powers the output stage for channel 2 and is monitored by overvoltage/undervoltage lockout comparators. V_{IN1} voltage must be greater than 2.8V for V_{IN2} operation. The V_{IN2} pin is also the collector of channel 2's on-chip power NPN switch. The V_{IN2} pin has high dI/dt edges and must be decoupled to ground close to the pin of the device.

$V_{OUT1/2}$: The V_{OUT} pin is the output to the internal sense resistor that measures current flowing in the inductor. When the current in the resistor exceeds the current dictated by the V_C pin, the SW latch is held in reset disabling the output switch. Bias current flows out of the V_{OUT} pin.

BLOCK DIAGRAM

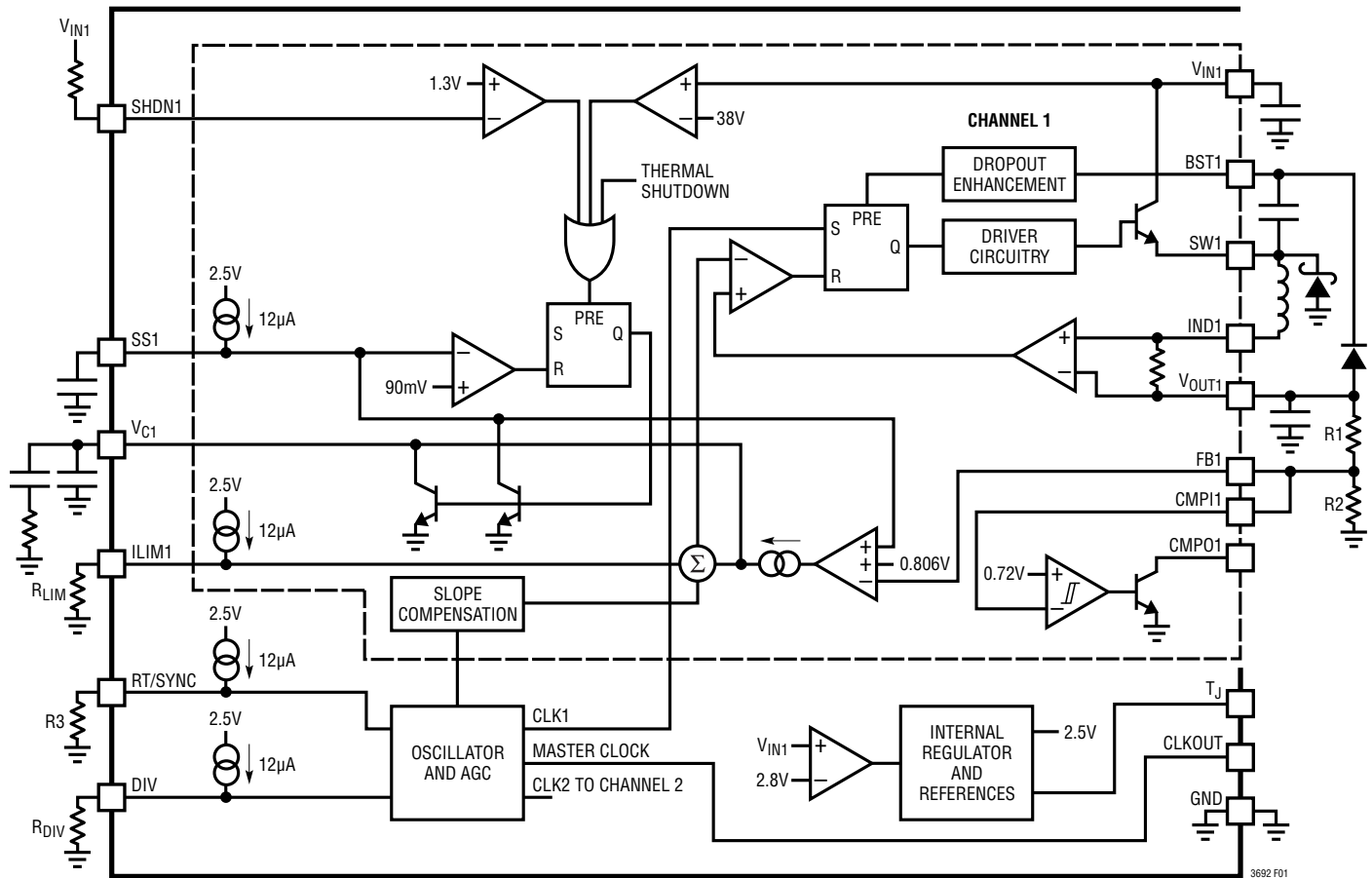

Figure 1. LT3692 Block Diagram

The LT3692 is a dual channel, constant frequency, current mode buck converter with internal 3.5A switches. Each channel can be independently controlled with the exception that V_{IN1} must be above the 2.8V undervoltage lockout threshold to power the common internal regulator, oscillator and thermometer circuitry.

If the SHDN1 pin is taken below its 1.3V threshold the LT3692 will be placed in a low quiescent current mode. In this mode the LT3692 typically draws $6\mu A$ from V_{IN1} and $<1\mu A$ from V_{IN2} . When the SHDN pin is driven above 1.3V, the internal bias circuits turn on generating an internal regulated voltage, $0.806V_{FB}$, $12\mu A$ RT/SYNC, DIV and ILIM current references, and a POR signal which sets the soft-start latch.

Once the internal reference reaches its regulation point, the internal oscillator will start generating a master clock signal for the two regulators at a frequency determined by the voltage present at the RT/SYNC pin. The channel 1 clock is then divided by 1, 2, 4 or 8 depending on the voltage present at the DIV pin. Channel 2's clock runs at the master clock frequency with a 180° phase shift from channel 1.

Alternatively, if a synchronization signal is detected by the LT3692 the RT/SYNC pin, the master clock will be generated at the incoming frequency on the rising edge of the synchronization pulse with channel 1 in phase with the synchronization signal. Frequency division and phase remains the same as the internally generated master clock.

BLOCK DIAGRAM

In addition, the internal slope compensation will be automatically adjusted to prevent subharmonic oscillation during synchronization. In either mode of oscillator operation, a square wave with the master clock frequency, synchronized to channel 1 is present at the CLKOUT pin.

The two regulators are constant frequency, current mode step-down converters. Current mode regulators are controlled by an internal clock and two feedback loops that control the duty cycle of the power switch. In addition to the normal error amplifier, there is a current sense amplifier that monitors switch current on a cycle-by-cycle basis. This technique means that the error amplifier commands current to be delivered to the output rather than voltage. A voltage fed system will have low phase shift up to the resonant frequency of the inductor and output capacitor, then an abrupt 180° shift will occur. The current fed system will have 90° phase shift at a much lower frequency, but will not have the additional 90° shift until well beyond the LC resonant frequency. This makes it much easier to frequency compensate the feedback loop and also gives much quicker transient response.

The Block Diagram in Figure 1 shows only one of the switching regulators whose operation will be discussed below. The additional regulator will operate in a similar manner with the exception that its clock will be 180° out of phase with the other regulator.

When, during power-up, an internal POR signal sets the soft-start latch, both SS pins will be discharged to ground to ensure proper start-up operation. When the SS pin voltage drops below 90mV, the V_C pin is driven low disabling switching and the soft-start latch is reset. Once the latch is reset the soft-start capacitor starts to charge with a typical value of 12 μ A.

As the voltage rises above 115mV on the SS pin, the V_C pin will be driven high by the error amplifier. When the voltage on the V_C pin exceeds 0.8V, the clock set-pulse sets the driver flip-flop, which turns on the internal power NPN switch. This causes current from V_{IN} , through the NPN switch, inductor and internal sense resistor to increase. When the voltage drop across the internal sense resistor exceeds a predetermined level set by the voltage on the V_C pin, the flip-flop is reset and the internal NPN switch

is turned off. Once the switch is turned off the inductor will drive the voltage at the SW pin low until the external Schottky diode starts to conduct, decreasing the current in the inductor. The cycle is repeated with the start of each clock cycle. However, if the internal sense resistor voltage exceeds the predetermined level at the start of a clock cycle, the flip-flop will not be set resulting in a further decrease in inductor current. Since the output current is controlled by the V_C voltage, output regulation is achieved by the error amplifier continually adjusting the V_C pin voltage.

The error amplifier is a transconductance amplifier that compares the FB voltage to the lowest voltage present at either the SS pin or an internal 806mV reference. Compensation of the loop is easily achieved with a simple capacitor or series resistor/capacitor from the V_C pin to ground.

The regulators' maximum output current occurs when the V_C pin is driven to its maximum clamp value by the error amplifier. The value of the maximum switch current can be programmed from 4.8A to 2A by placing a resistor from the ILIM pin to ground.

Since the SS pin is driven by a constant current source, a single capacitor on the soft-start pin will generate controlled linear ramp on the output voltage.

If the current demanded by the output exceeds the maximum current dictated by the V_C pin clamp, the SS pin will be discharged, lowering the regulation point until the output voltage can be supported by the maximum current. Once the overload condition is removed, the regulator will soft-start from the overload regulation point.

Shutdown control, V_{IN} overvoltage, or thermal shutdown will set the soft-start latch, resulting in a complete soft-start sequence.

The switch driver operates from either the V_{IN} or BST voltage. An external diode and capacitor are used to generate a drive voltage higher than V_{IN} to saturate the output NPN and maintain high efficiency. If the BST capacitor voltage is sufficient, the switch is allowed to operate to 100% duty cycle. If the boost capacitor discharges towards a level insufficient to drive the output NPN, a BST pin comparator forces a minimum cycle off time, allowing the boost capacitor to recharge.

BLOCK DIAGRAM

A comparator with a threshold of 720mV and 60mV of hysteresis is provided for detecting error conditions. The CMPO output is an open-collector NPN that is off when the CMPI pin is above the threshold allowing a resistor to pull the CMPO pin to a desired voltage.

The voltage present at the T_J pin is proportional to the junction temperature of the LT3692. The T_J pin will be 250mV for a die temperature of 25°C and will have a slope of 10mV/°C.

APPLICATIONS INFORMATION

Choosing the Output Voltage

The output voltage is programmed with a resistor divider between the output and the FB pin. Choose the 1% resistors according to:

$$R1 = R2 \cdot \left(\frac{V_{OUT}}{0.806} - 1 \right)$$

R2 should be 10k or less to avoid bias current errors. Reference designators refer to the Block Diagram in Figure 1.

Choosing the Switching Frequency

The LT3692 switching frequency is set by resistor R3 in Figure 1. The RT/SYNC pin is driven by a 12µA current source. Setting resistor R3 sets the voltage present at the RT/SYNC pin which determines the master oscillator frequency as illustrated in Figure 2. A 0V to 2.5V square wave with the same frequency as the master oscillator and in phase with channel 1 is output via the CLKOUT pin. The CLKOUT signal can be used to synchronize multiple switching regulators.

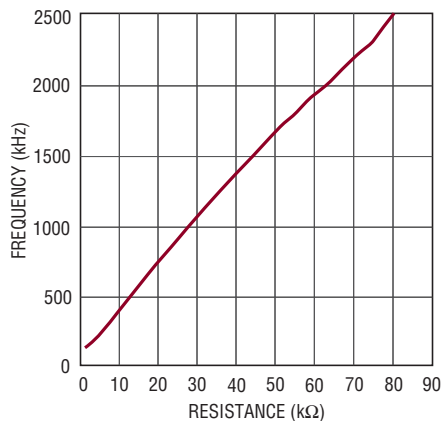

Figure 2. Switching Frequency vs RT/SYNC Resistance

To alleviate duty cycle restrictions due to minimum switch-on times, channel 1's switching frequency can be divided from the master clock by 1, 2, 4 or 8 determined by resistor R_{DIV} in Figure 1. Channel 2's switching frequency is not affected by the DIV pin. The DIV pin is driven by a 12µA current source. Setting resistor R_{DIV} sets the voltage present at the DIV pin which determines the divisor as shown in Table 1. The DIV pin doesn't have any input hysteresis near the ratio thresholds.

Table 1. Channel 1 Divisor vs V_{DIV}

DIV VOLTAGE	FREQUENCY RATIO	R _{DIV}
V _{DIV} < 0.5V	1	0
0.5V < V _{DIV} < 1.0V	2	62k
1.0V < V _{DIV} < 1.5V	4	100k
1.5V < V _{DIV}	8	150k

The switching frequency is typically set as high as possible to reduce overall solution size. The LT3692 employs techniques to enhance dropout at high frequencies but efficiency and maximum input voltage decrease due to switching losses and minimum switch on times.

The maximum recommended frequency can be approximated by the equation:

$$\text{Frequency (Hz)} = \frac{V_{OUT} + V_D}{V_{IN} - V_{SW} + V_D} \cdot \frac{1}{t_{ON(MIN)}}$$

where V_D is the forward voltage drop of the catch diode (D1 Figure 2), V_{SW} is the voltage drop of the internal switch, and t_{ON(MIN)} is the minimum on-time of the switch.

The following example along with the data in Table 2 illustrates the trade-offs of switch frequency selection for a single input voltage system.

APPLICATIONS INFORMATION

Table 2. Efficiency and Size Comparisons for Different $R_{RT/SYNC}$ Values, 3.3V Output

FREQUENCY	RT/SYNC	EFFICIENCY $V_{VIN1/2} = 12V$	$V_{IN(MAX)}^{\dagger}$	L^*	C^*	$C + L$ (Area)
250kHz	5.90k Ω	77.8%	38V	12 μ H	120 μ F	59.8mm ²
500kHz	13.0k Ω	81.2%	31V	6.8 μ H	60 μ F	54.6mm ²
1000kHz	28.0k Ω	80.5%	16V	3.3 μ H	30 μ F	51.9mm ²
1500kHz	44.2k Ω	79.3%	10V	1.5 μ H	22 μ F	46.9mm ²
2250kHz	71.5k Ω	76.7%	6.5V	0.82 μ H	15 μ F	19.1mm ²

[†] $V_{IN(MAX)}$ is defined as the highest input voltage that maintains constant output voltage ripple.

*Inductor and capacitor values chosen for stability and constant ripple current.

Example.

$V_{IN} = 25V$, $V_{OUT} = 3.3V$, $I_{OUT} = 2.5A$, $t_{ON(MIN)} = 250ns$,
 $V_D = 0.6V$, $V_{SW} = 0.4V$:

$$\text{Max Frequency} = \frac{3.3 + 0.6}{25 - 0.4 + 0.6} \cdot \frac{1}{250e-9} \sim 600\text{kHz}$$

$R_{T/SYNC} \sim 15.8k\Omega$ (Figure 2)

Input Voltage Range

Once the switching frequency has been determined, the input voltage range of the regulator can be determined. The minimum input voltage is determined by either the LT3692's minimum operating voltage of $\sim 2.8V$, or by its maximum duty cycle. The duty cycle is the fraction of time that the internal switch is on during a clock cycle. Unlike most fixed frequency regulators, the LT3692 will not switch off at the end of each clock cycle if there is sufficient voltage across the boost capacitor (C3 in Figure 1) to fully saturate the output switch. Forcing switch off for a minimum time will only occur at the end of a clock cycle when the boost capacitor needs to be recharged. This operation

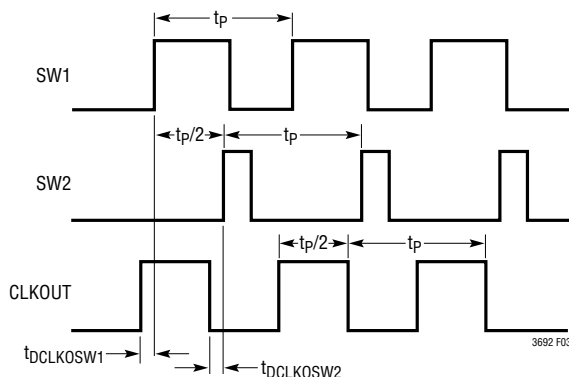

Figure 3. Timing Diagram $R_{T/SYNC} = 28.0k$, $t_p = 1\mu s$, $V_{DIV} = 0V$

has the same effect as lowering the clock frequency for a fixed off time, resulting in a higher duty cycle and lower minimum input voltage. The resultant duty cycle depends on the charging times of the boost capacitor and can be approximated by the following equation:

$$DC_{MAX} = \frac{1}{1 + \frac{1}{B}}$$

where B is 3A divided by the typical boost current from the Electrical Characteristics table.

This leads to a minimum input voltage of:

$$V_{IN(MIN)} = \frac{V_{OUT} + V_D}{DC_{MAX}} - V_D + V_{SW}$$

where V_{SW} is the voltage drop of the internal switch.

Figure 4 shows a typical graph of minimum input voltage vs load current for Figure 19, the 3.3V and 1.8V application.

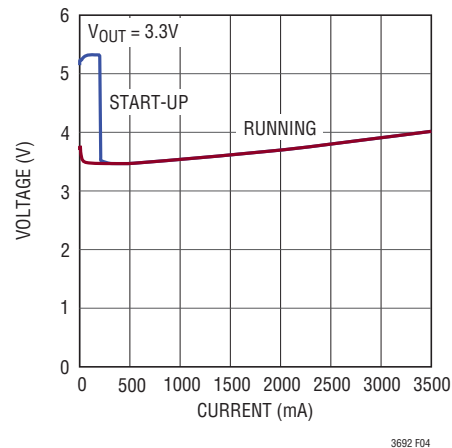

Figure 4. Minimum Input Voltage vs Load Current

APPLICATIONS INFORMATION

The maximum input voltage is determined by the absolute maximum ratings of the V_{IN} and BST pins and by the frequency and minimum duty cycle. The minimum duty cycle is defined as:

$$DC_{MIN} = t_{ON(MIN)} \cdot \text{Frequency}$$

Maximum input voltage as:

$$V_{IN(MAX)} = \frac{V_{OUT} + V_D}{DC_{MIN}} - V_D + V_{SW}$$

Note that the LT3692 will regulate if the input voltage is taken above the calculated maximum voltage as long as maximum ratings of the V_{IN} and BST pins are not violated. However operation in this region of input voltage will exhibit pulse skipping behavior.

Example:

$V_{OUT} = 3.3V$, $I_{OUT} = 1A$, Frequency = 1MHz, Temperature = 25°C, $V_{SW} = 0.1V$, B = 50 (from boost characteristics specification), $V_D = 0.4V$, $t_{ON(MIN)} = 225ns$:

$$DC_{MAX} = \frac{1}{1 + \frac{1}{50}} = 98\%$$

$$V_{IN(MIN)} = \frac{3.3 + 0.4}{0.98} - 0.4 + 0.1 = 3.48V$$

$$DC_{MIN} = t_{ON(MIN)} \cdot \text{Frequency} = 0.225$$

$$V_{IN(MAX)} = \frac{3.3 + 0.4}{0.225} - 0.4 + 0.1 = 16.1V$$

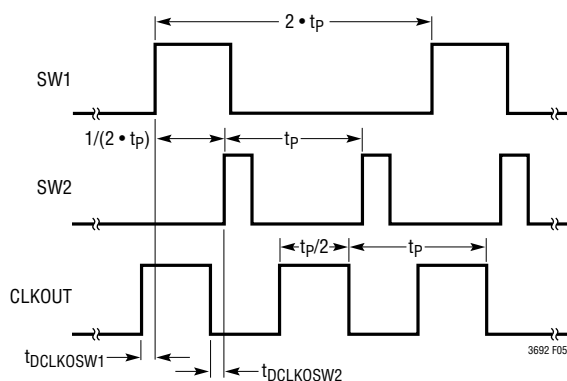

Figure 5. Timing Diagram RT/SYNC = 28.0k,
 $t_p = 1\mu s$, $V_{DIV} = 0.75V$

In cases where multiple input voltages are present, or the V_{IN}/V_{OUT} ratio for channel 1 is significantly different than channel 2, channel 1's frequency can be divided by a factor of 2, 4 or 8 from the programmed value by setting the DIV pin resistor to the appropriate value. Dividing channel 1's frequency will increase the maximum input voltage by the same ratio. Channel 1's external components will have to be chosen according to the resulting frequency.

Example:

$V_{OUT} = 3.3V$, $I_{OUT} = 1A$, Frequency = 1MHz, Temperature = 25°C, $V_{SW} = 0.1V$, B = 50 (from boost characteristics specification), $V_D = 0.4V$, $t_{ON(MIN)} = 225ns$, $V_{DIV} = 0.75V$.

$$DC_{MIN1} = t_{ON(MIN1)} \cdot \text{Frequency}/2 = 0.1125$$

$$V_{IN1(MAX)} = \frac{3.3 + 0.4}{0.1125} - 0.4 + 0.1 = 32.6V$$

Inductor Selection and Maximum Output Current

A good first choice for the LT3692 inductor value is:

$$L = \frac{V_{OUT}}{f}$$

where f is frequency in MHz and L is in μH .

With this value the maximum load current will be ~3.5A, independent of input voltage. The inductor's RMS current rating must be greater than your maximum load current and its saturation current should be higher than the maximum peak switch current, and will reduce the output voltage ripple.

If the maximum load for a single channel is lower than 2.5A, then you can decrease the value of the inductor and operate with higher ripple current, or you can adjust the maximum switch current for the channel via the ILIM pin. This allows you to use a physically smaller inductor, or one with a lower DCR resulting in higher efficiency.

The peak inductor and switch current is:

$$I_{SW(PK)} = I_{L(PK)} = I_{OUT} + \frac{\Delta I_L}{2}$$

To maintain output regulation, this peak current must be less than the LT3692's switch current limit, ILIM. ILIM

APPLICATIONS INFORMATION

can be set between 2A and 4.8A for each channel via a resistor from the ILIM pin to ground. The ILIM pin is driven by a 12μA current source. Setting resistor R_{ILIM} sets the voltage present at the ILIM pin which determines the maximum switch current as illustrated in Figure 6. A capacitor from the ILIM pin to ground, or a resistor divider from the output, can be used to limit the peak current during start-up. If a capacitor is used it must be discharged before power-up to ensure proper operation (see 3.3V and 1.8V 2-Stage Dual Step-Down Multi-Frequency Converter in Typical Applications).

Referring to Figure 6, as the peak current limit is reduced, slope compensation further reduces the peak current with increasing duty cycle.

When the ILIM pin is used to reduce the peak switch current, the equation for inductor choice becomes:

$$L = \frac{50 \cdot V_{OUT}}{f \cdot R_{ILIM}}$$

where f is frequency in MHz, L in μH and R in kΩ.

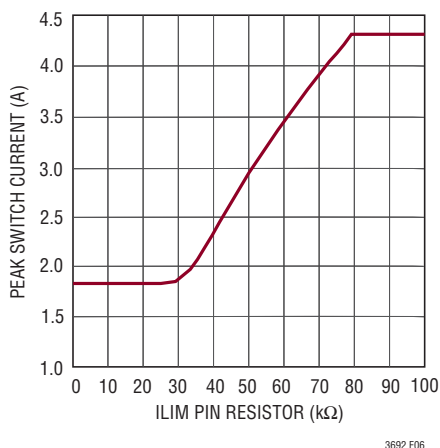

Figure 6. Peak Switch Current vs ILIM Resistor

Input Capacitor Selection

Bypass the inputs of the LT3692 circuit with a 4.7μF or higher ceramic capacitor of X7R or X5R type. A lower value or a less expensive Y5V type can be used if there is additional bypassing provided by bulk electrolytic or tantalum capacitors.

When the LT3692’s input supplies are operated at different input voltages, an input capacitor sized for that channel should be placed as close as possible to the respective V_{IN} pins.

A caution regarding the use of ceramic capacitors at the input. A ceramic input capacitor can combine with stray inductance to form a resonant tank circuit. If power is applied quickly (for example by plugging the circuit into a live power source) this tank can ring, doubling the input voltage and damaging the LT3692. The solution is to either clamp the input voltage or dampen the tank circuit by adding a lossy capacitor in parallel with the ceramic capacitor. For details, see Application Note 88.

Output Capacitor Selection

Typically step-down regulators are easily compensated with an output crossover frequency that is 1/10 of the switching frequency. This means that the time that the output capacitor must supply the output load during a transient step is ~2 or 3 switching periods. With an allowable 1% drop in output voltage during the step, a good starting value for the output capacitor can be expressed by:

$$C_{VOUT} = \frac{\text{Max Load Step}}{\text{Frequency} \cdot 0.01 \cdot V_{OUT}}$$

Example:

V_{OUT} = 3.3V, Frequency = 1MHz, Max Load Step = 2A.

$$C_{VOUT} = \frac{2}{1E6 \cdot 0.01 \cdot 3.3V} = 60\mu F$$

The calculated value is only a suggested starting value. Increase the value if transient response needs improvement or reduce the capacitance if size is a priority. The output capacitor filters the inductor current to generate an output with low voltage ripple. It also stores energy in order to satisfy transient loads and to stabilize the LT3692’s control loop. The switching frequency of the LT3692 determines the value of output capacitance required. Also, the current mode control loop doesn’t require the presence of output capacitor series resistance (ESR). For these reasons, you are free to use ceramic capacitors to achieve very low output ripple and small circuit size.

APPLICATIONS INFORMATION

You can also use electrolytic capacitors. The ESRs of most aluminum electrolytics are too large to deliver low output ripple. Tantalum and newer, lower ESR organic electrolytic capacitors intended for power supply use, are suitable and the manufacturers will specify the ESR. The choice of capacitor value will be based on the ESR required for low ripple. Because the volume of the capacitor determines its ESR, both the size and the value will be larger than a ceramic capacitor that would give you similar ripple performance. One benefit is that the larger capacitance may give better transient response for large changes in load current. Table 3 lists several capacitor vendors.

Table 3

VENDOR	TYPE	SERIES
Taiyo Yuden	Ceramic X5R, X7R	
AVX	Ceramic X5R, X7R Tantalum	
Kemet	Tantalum TA Organic AL Organic	T491, T494, T495 T520 A700
Sanyo	TA/AL Organic	POSCAP
Panasonic	AL Organic	SP CAP
TDK	Ceramic X5R, X7R	

Catch Diode

The diode D1 conducts current only during switch off time. Use a Schottky diode to limit forward voltage drop to increase efficiency. The Schottky diode must have a peak reverse voltage that is equal to regulator input voltage and sized for average forward current in normal operation. Average forward current can be calculated from:

$$I_{D(AVG)} = \frac{I_{OUT}}{V_{IN}} \cdot (V_{IN} - V_{OUT})$$

With a shorted condition, diode current will increase to the typical value determined by the peak switch current limit of the LT3692 set by the ILIM pin. This is safe for short periods of time, but it would be prudent to check with the diode manufacturer if continuous operation under these conditions can be tolerated.

BST Pin Considerations

The capacitor and diode tied to the BST pin generate a voltage that is higher than the input voltage. In most cases a 0.47µF capacitor and a small Schottky diode (such as the CMDSH-4E) will work well. To ensure optimal performance at duty cycles greater than 80%, use a 0.5A Schottky diode (such as a PMEG4005). Almost any type of film or ceramic capacitor is suitable, but the ESR should be <1Ω to ensure it can be fully recharged during the off time of the switch. The capacitor value can be approximated by:

$$C_{BST} = \frac{I_{OUT(MAX)} \cdot V_{OUT}}{5 \cdot V_{IN} (V_{OUT} - 2) \cdot f}$$

where $I_{OUT(MAX)}$ is the maximum load current.

Figure 7 shows four ways to arrange the boost circuit. The BST pin must be more than 3V above the SW pin for full efficiency. Generally, for outputs of 3.3V and higher the standard circuit (Figure 7a) is the best. For lower output voltages the boost diode can be tied to the input (Figure 7b). The circuit in Figure 7a is more efficient because the BST pin current comes from a lower voltage source. Figure 7c shows the boost voltage source from available DC sources that are greater than 3V. The highest efficiency is attained by choosing the lowest boost voltage above 3V. For example, if you are generating 3.3V and 1.8V and the 3.3V is on whenever the 1.8V is on, the 1.8V boost diode can be connected to the 3.3V output. In any case, you must also be sure that the maximum voltage at the BST pin is less than the maximum specified in the Absolute Maximum Ratings section.

The boost circuit can also run directly from a DC voltage that is higher than the input voltage by more than 3V, as in Figure 7d. The diode is used to prevent damage to the LT3692 in case V_X is held low while V_{IN} is present. The circuit saves several components (both BST pins can be tied to D2). However, efficiency may be lower and dissipation in the LT3692 may be higher. Also, if V_X is absent, the LT3692 will still attempt to regulate the output, but will do so with very low efficiency and high dissipation because

APPLICATIONS INFORMATION

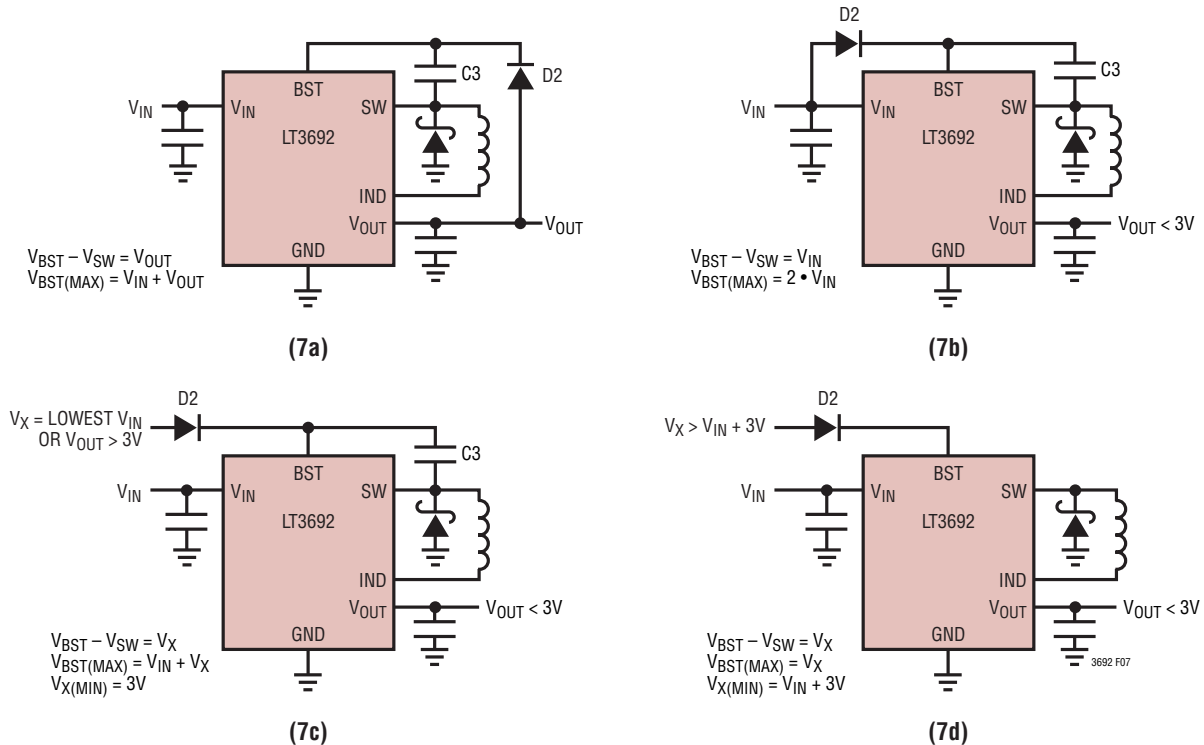

Figure 7. BST Pin Considerations

the switch will not be able to saturate, dropping 1.5V to 2V in conduction.

The minimum input voltage of an LT3692 application is limited by the minimum operating voltage (<3V) and by the maximum duty cycle as outlined above. For proper start-up, the minimum input voltage is also limited by the boost circuit. If the input voltage is ramped slowly, or the LT3692 is turned on with its SS pin when the output is already in regulation, then the boost capacitor may not be fully charged. Because the boost capacitor is charged with the energy stored in the inductor, the circuit will rely on some minimum load current to get the boost circuit running properly. This minimum load will depend on input and output voltages, and on the arrangement of the boost circuit. The Typical Performance Characteristics section shows plots of the minimum load current to start and to run as a function of input voltage for 3.3V outputs. In many cases the discharged output capacitor will present a load to the switcher which will allow it to start. The plots show the worst-case situation where V_{IN} is ramping very slowly. Use a Schottky diode for the lowest start-up voltage.

Outputs Greater Than 6V

For outputs greater than 6V, add a resistor of 1k to 2.5k across the inductor to damp the discontinuous ringing of the SW node, preventing unintended SW current. The 12V output circuit in the Typical Applications section shows the location of this resistor.

Frequency Compensation

The LT3692 uses current mode control to regulate the output. This simplifies loop compensation. In particular, the LT3692 does not require the ESR of the output capacitor for stability so you are free to use ceramic capacitors to achieve low output ripple and small circuit size. Frequency compensation is provided by the components tied to the V_C pin. Generally a capacitor and a resistor in series to ground determine loop gain. In addition, there is a lower value capacitor in parallel. This capacitor is not part of the loop compensation but is used to filter noise at the switching frequency.

APPLICATIONS INFORMATION

Loop compensation determines the stability and transient performance. Designing the compensation network is a bit complicated and the best values depend on the application and in particular the type of output capacitor. A practical approach is to start with one of the circuits in this data sheet that is similar to your application and tune the compensation network to optimize the performance. Stability should then be checked across all operating conditions, including load current, input voltage and temperature.

The LT1375 data sheet contains a more thorough discussion of loop compensation and describes how to test the stability using a transient load.

Figure 8 shows an equivalent circuit for the LT3692 control loop. The error amp is a transconductance amplifier with finite output impedance. The power section, consisting of the modulator, power switch and inductor, is modeled as a transconductance amplifier generating an output current proportional to the voltage at the V_C pin. Note that the output capacitor integrates this current, and that the capacitor on the V_C pin (C_C) integrates the error amplifier output current, resulting in two poles in the loop. In most cases a zero is required and comes from either the output capacitor ESR or from a resistor in series with C_C .

This simple model works well as long as the value of the inductor is not too high and the loop crossover frequency is much lower than the switching frequency. A phase lead capacitor (C_{PL}) across the feedback divider may improve the transient response.

Synchronization

The RT/SYNC pin can also be used to synchronize the regulators to an external clock source. Driving the RT/SYNC resistor with a clock source triggers the synchronization detection circuitry. Once synchronization is detected, the rising edge of SW1 will be synchronized to the rising edge of the RT/SYNC signal and the rising edge of SW2 synchronized to the falling edge of the RT/SYNC signal (see Figures 10 and 11). During synchronization, a 0V to 2.4V square wave with the same frequency and duty cycle as the synchronization signal is output via the CLKOUT pin with a typical propagation delay of 250ns. In addition, an internal AGC loop will adjust slope compensation to avoid subharmonic oscillation. If the synchronization signal is halted, the synchronization detection circuitry will timeout in typically 10 μ s at which time the LT3692 reverts to the free-running frequency based on the RT/SYNC pin voltage.

The synchronizing clock signal input to the LT3692 must have a frequency between 200kHz and 2MHz, a duty cycle between 20% and 80%, a low state below 0.5V and a high state above 1.6V. Synchronization signals outside of these parameters will cause erratic switching behavior. If the RT/SYNC pin is held above 1.6V at any time, switching will be disabled.

If the synchronization signal is not present during regulator start-up (for example, the synchronization circuitry is powered from the regulator output) the RT/SYNC pin must remain below 1V until the synchronization circuitry is active for proper start-up operation.

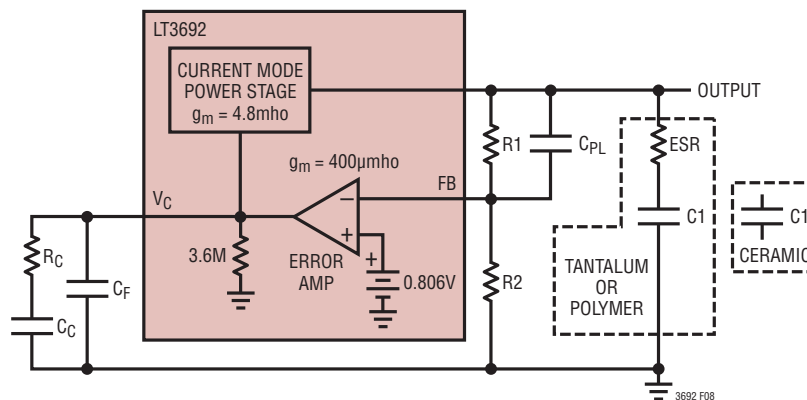

Figure 8. Model for Loop Response

APPLICATIONS INFORMATION

If the synchronization signal powers up in an undetermined state (V_{OL} , V_{OH} , Hi-Z), connect the synchronization clock to the LT3692 as shown in Figure 9. The circuit as shown will isolate the synchronization signal when the output voltage is below 90% of the regulated output. The LT3692 will start up with a switching frequency determined by the resistor from the RT/SYNC pin to ground.

If the synchronization signal powers up in a low impedance state (V_{OL}), connect a resistor between the RT/SYNC pin and the synchronizing clock. The equivalent resistance seen from the RT/SYNC pin to ground will set the start-up frequency.

If the synchronization signal powers up in a high impedance state (Hi-Z), connect a resistor from the RT/SYNC pin to ground. The equivalent resistance seen from the RT/SYNC pin to ground will set the start-up frequency.

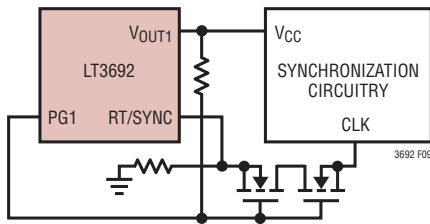

Figure 9. Synchronous Signal Powered from Regulator's Output

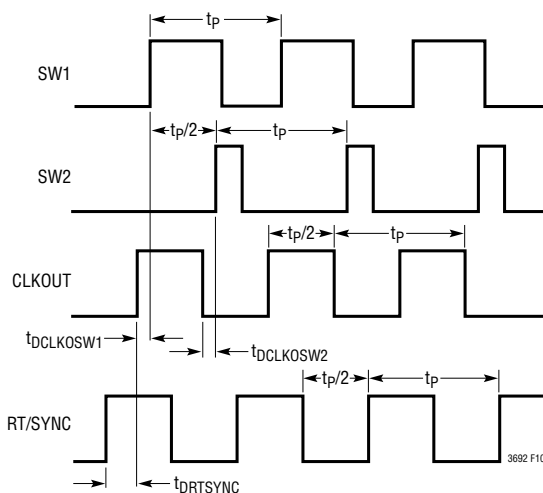

Figure 10. Timing Diagram RT/SYNC = 1MHz, Duty Cycle = 50%

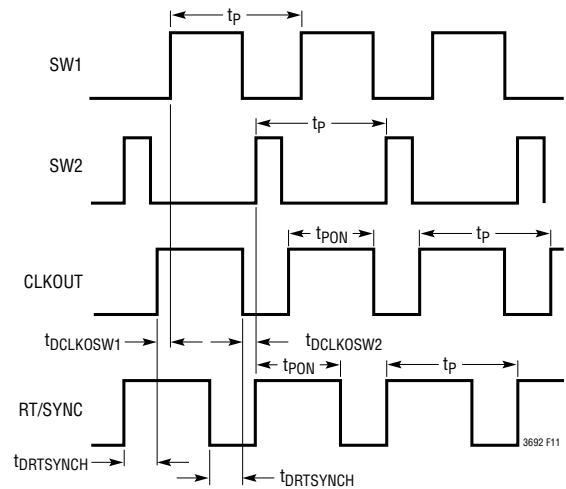

Figure 11. Timing Diagram RT/SYNC = 1MHz, Duty Cycle > 50%

Reducing Input Ripple Voltage

Synchronizing the switches to the rising and falling edges of the synchronization signal provides the unique ability to reduce input ripple currents in systems where V_{IN1} and V_{IN2} are connected to the same supply. Decreasing the input current ripple reduces the required input capacitance. For example, the input ripple voltage shown in Figure 12 for a typical antiphase dual 14.4V to 8.5V and 14.4V to 3.3V regulator is decreased from a peak of 472mV to 160mV as shown in Figure 13 by driving the LT3692 with a 71% duty cycle synchronization signal.

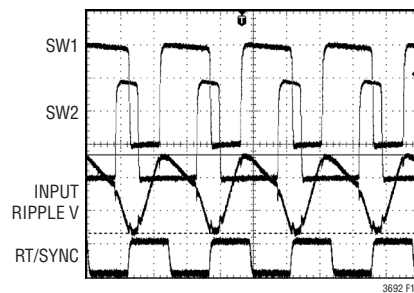

Figure 12. Dual 14.4V/8.5V, 14.4V/3.3V with 180° Phase

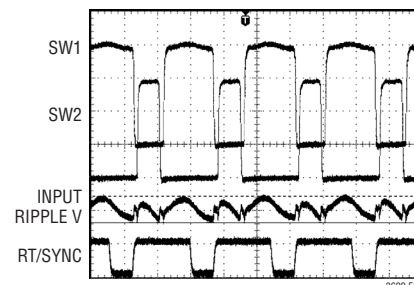

Figure 13. Dual 14.4V/8.5V, 14.4V/3.3V with 256° Phase

APPLICATIONS INFORMATION

Shutdown and Undervoltage/Overvoltage Lockout

Typically, undervoltage lockout (UVLO) is used in situations where the input supply is current limited, or has a relatively high source resistance. A switching regulator draws constant power from the source, so source current increases as source voltage drops. This looks like a negative resistance load to the source and can cause the source to current limit or latch low under low source voltage conditions. UVLO prevents the regulator from operating at source voltages where these problems might occur.

Overvoltage lockout (OVLO) is typically used to shut down the switching regulator during potentially harmful input voltage transients.

Referring to Figure 14, if the SHDN pin is connected to V_{IN} , then the overvoltage lockout threshold is set to the typical maximum value of 38V.

Additionally, an internal comparator will force both channels into shutdown below the minimum V_{IN1} of 2.8V. This feature can be used to prevent excessive discharge of battery-operated systems. In addition to the V_{IN1} undervoltage lockout, both channels will be disabled when SHDN1 is less than 1.3V.

Programmable UVLO may be implemented using an input voltage divider and one of the internal comparators (see the Typical Applications section).

When the SHDN pin is taken above 1.3V, its respective channel is allowed to operate. When the SHDN pin is driven below 1.3V, its channel is placed in a low quiescent current state. There is no hysteresis on the SHDN pins. If the SHDN pins are not connected to V_{IN} , then an internal clamp regulates the SHDN pin voltage to 2.5V.

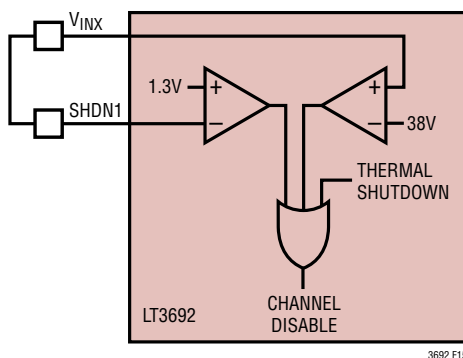

Figure 14. Connect SHDN to V_{IN} to Select Default OVLO and UVLO

If the SHDN pin is driven by a logic signal greater than 2.5V, a series resistor is required to limit the current into the SHDN pin to no more than 10 μ A.

Referring to Figure 15, a 249k resistor will suffice for a typical logic-level signal. If the logic signal is 5V or greater, choose a current limiting resistor equal to $R_{SHDN} = (V_{LOGIC} - 2.5V)/10\mu A$. Place a small Schottky diode (such as a BAT54) in parallel to the current-limiting resistor as shown in Figure 15.

Keep the connections from any series resistors to the SHDN pins short and make sure that the interplane or surface capacitance to switching nodes is minimized.

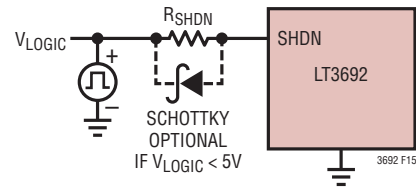

Figure 15. External Control of the SHDN Pin

Soft-Start

The output of the LT3692 regulates to the lowest voltage present at either the SS pin or an internal 0.806V reference. A capacitor from the SS pin to ground is charged by an internal 12 μ A current source resulting in a linear output ramp from 0V to the regulated output whose duration is given by:

$$t_{RAMP} = \frac{C_{SS} \cdot 0.806V}{12\mu A}$$

At power-up, a reset signal sets the soft-start latch and discharges both SS pins to approximately 0V to ensure proper start-up. When both SS pins are fully discharged the latch is reset and the internal 12 μ A current source starts to charge the SS pin.

When the SS pin voltage is below 115mV, the V_C pin is pulled low which disables switching. This allows the SS pin to be used as an individual shutdown for each channel.

As the SS pin voltage rises above 90mV, the V_C pin is released and the output is regulated to the SS voltage. When the SS pin voltage exceeds the internal 0.806V reference,

APPLICATIONS INFORMATION

the output is regulated to the reference. The SS pin voltage will continue to rise until it is clamped at 2V.

In the event of a V_{IN1} undervoltage lockout, the soft-start latch is set for both channels, triggering a full start-up sequence. If a channel's SHDN pin is driven below 1.3V, its overvoltage lockout is enabled, or the internal die temperature for its power switch exceeds its maximum rating during normal operation, the soft-start latch is set for that channel.

In addition, if the load exceeds the maximum output switch current, the output will start to drop causing the V_C pin clamp to be activated. As long as the V_C pin is clamped, the SS pin will be discharged. As a result, the output will be regulated to the highest voltage that the maximum output current can support. For example, if a 6V output is loaded by 1Ω the SS pin will drop to 0.48V, regulating the output at 4.8V ($4.8A \cdot 1\Omega$). Once the overload condition is removed, the output will soft start from the temporary voltage level to the normal regulation point.

Since the SS pin is clamped at 2V and has to discharge to 0.806V before taking control of regulation, momentary overload conditions will be tolerated without a soft-start recovery. The typical time before the SS pin takes control is:

$$t_{SS(\text{CONTROL})} = \frac{C_{SS} \cdot 1.2V}{1.4mA}$$

Open-Collector Comparators

The CMPO pin is the open-collector output of an internal comparator. The comparator compares the CMPI pin voltage to 90% of the reference voltage (0.72V) with 60mV of hysteresis.

The CMPO pin has a typical sink capability of $300\mu A$ when the CMPI pin is below the threshold and can withstand 38V when the threshold is exceeded. The CMPO pin is active (sink capability is reduced in shutdown and undervoltage lockout mode) as long as the V_{IN1} pin voltage exceeds 2.8V.

The comparators can be used to monitor input and output voltages as well as die temperature. See the Typical Applications circuit collection for examples.

Output Tracking/Sequencing

Complex output tracking and sequencing between channels can be implemented using the LT3692's SS and CMPO pins. Figure 16 shows several configurations for output tracking/sequencing for a 3.3V and 1.8V application.

Independent soft-start for each channel is shown in Figure 16a. The output ramp time for each channel is set by the soft-start capacitor as described in the soft-start section.

Ratiometric tracking is achieved in Figure 16b by connecting both SS pins together. In this configuration, the SS pin source current is doubled ($24\mu A$) which must be taken into account when calculating the output rise time.

By connecting a feedback network from V_{OUT1} to the SS2 pin with the same ratio that sets V_{OUT2} voltage, absolute tracking shown in Figure 16c is implemented. The minimum value of the top feedback resistor ($R1$) should be set such that the SS pin can be driven all the way to ground with 1.4mA of sink current when V_{OUT1} is at its regulated voltage. In addition, a small V_{OUT2} voltage offset will be present due to the SS2 $12\mu A$ source current. This offset can be corrected for by slightly reducing the value of $R2$.

Figure 16d illustrates output sequencing. When V_{OUT1} is within 10% of its regulated voltage, CMPO1 releases the SS2 soft-start pin allowing V_{OUT2} to soft-start. In this case CMPO1 will be pulled up to 2V by the SS pin. If a greater voltage is needed for CMPO1 logic, a pull-up resistor to V_{OUT1} can be used. This will decrease the soft-start ramp time and increase tolerance to momentary shorts.

If precise output ramp up and down is required, drive the SS pins as shown in Figure 16e. The minimum value of resistor ($R3$) should be set such that the SS pin can be driven all the way to ground with 1.4mA of sink current during power-up and fault conditions.

APPLICATIONS INFORMATION

Independent Start-Up

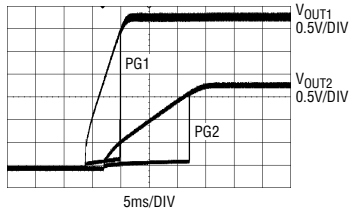

Ratiometric Start-Up

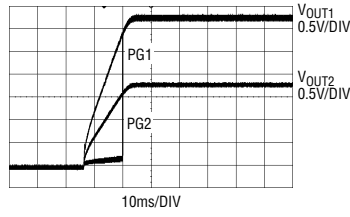

Absolute Start-Up

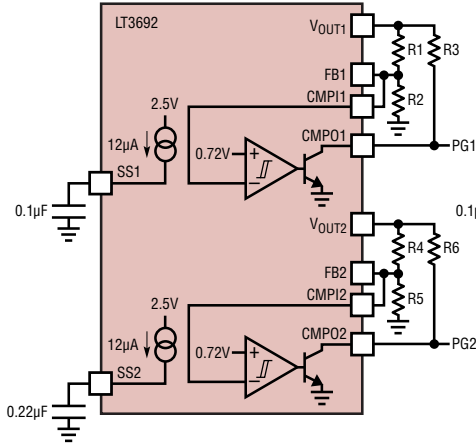
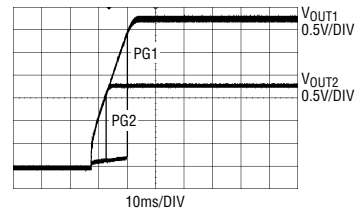

(16a)

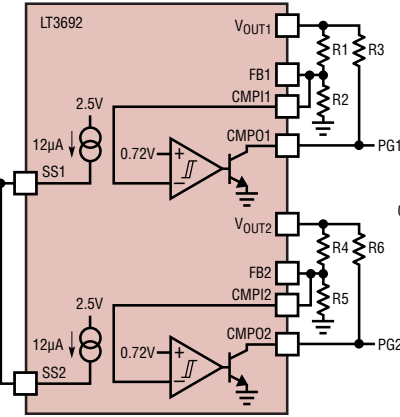

(16b)

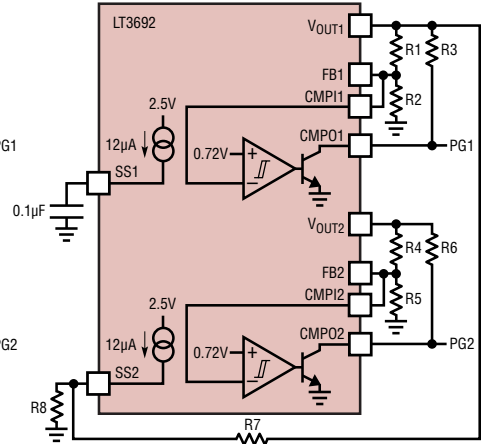

(16c)

Output Sequencing

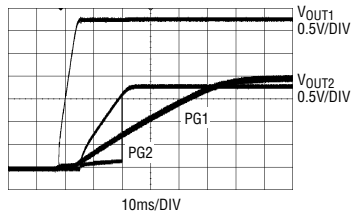

Controlled Power Up and Down

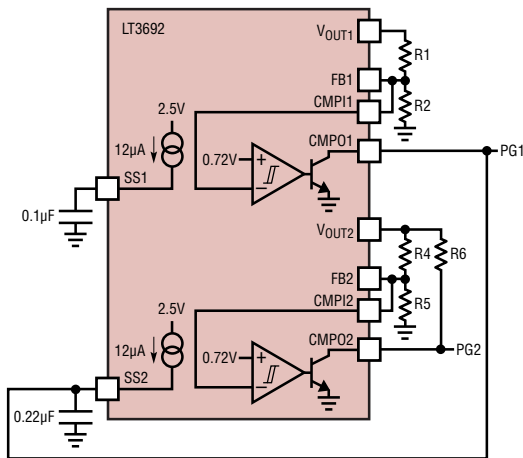
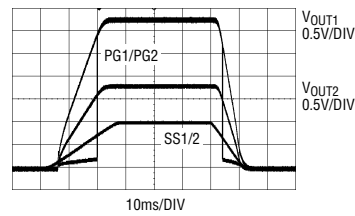

(16d)

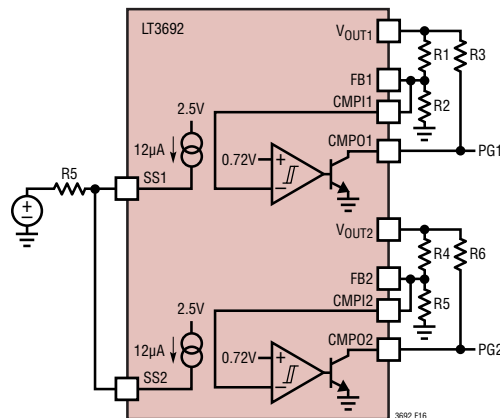

(16e)

Figure 16. SS Pin Configurations

APPLICATIONS INFORMATION

Application Optimization

In multiple channel applications requiring large V_{IN} to V_{OUT} ratios, the maximum frequency and resulting inductor size is determined by the channel with the largest ratio. The LT3692's multi-frequency operation allows the user to minimize component size for each channel while maintaining constant frequency operation. The circuit in Figure 17 illustrates this approach. A 2-stage step-down approach coupled with multi-frequency operation will further reduce external component size by allowing an increase in frequency for the channel with the lower V_{IN} to V_{OUT} ratio. The drawback to this approach is that the output power capability for the first stage is determined by the output power drawn from the second stage. The dual step-down application in Figure 18 steps down the input voltage (V_{IN1}) to the highest output voltage then uses that voltage to power the second output (V_{IN2}). V_{OUT1} must be able to provide enough current for its output plus V_{OUT2} maximum load. Note that the V_{OUT1} voltage must be above V_{IN2} 's minimum input voltage as specified in the Electrical Characteristics (2.8V) when the second channel starts to switch. Delaying channel 2 can be accomplished by either independent soft-start capacitors or sequencing with the CMP01 output.

For example, assume a maximum input of 36V:

$V_{IN} = 36V$, $V_{OUT1} = 3.3V$ at 1.5A and $V_{OUT2} = 1.8V$ at 1.5A.

$$\text{Frequency (Hz)} = \frac{V_{OUT} + V_D}{V_{IN} - V_{SW} + V_D} \cdot \frac{1}{t_{ON(MIN)}}$$

$$L = \frac{(V_{IN} - V_{OUT}) \cdot V_{OUT}}{V_{IN} \cdot f}$$

Single Step Down:

$$\text{Frequency (Hz)} = \frac{1.8 + 0.6}{36V - 0.4 + 0.6} \cdot \frac{1}{225ns} \cong 250kHz$$

$$L1 = \frac{(36V - 3.3) \cdot 3.3}{36V \cdot 250kHz} \geq 12\mu H$$

$$L2 = \frac{(36V - 1.8) \cdot 1.8}{36V \cdot 250kHz} \geq 6.8\mu H$$

2-Stage Step-Down:

$$\text{Frequency (Hz)} = \frac{3.3 + 0.6}{36V - 0.4 + 0.6} \cdot \frac{1}{225ns} \cong 400kHz$$

$$L1 = \frac{(36V - 3.3) \cdot 3.3}{36V \cdot 400kHz} \geq 7.5\mu H$$

$$L2 = \frac{(3.3 - 1.8) \cdot 1.8}{3.3 \cdot 400kHz} \geq 2\mu H$$

2-Stage Step-Down Multi-Frequency:

$R_{DIV} = 100k$, $FREQ1 = 400kHz$, $FREQ2 = 1600kHz$.

$$L1 = \frac{(36V - 3.3) \cdot 3.3}{36V \cdot 400kHz} \geq 7.5\mu H$$

$$L2 = \frac{(3.3 - 1.8) \cdot 1.8}{3.3 \cdot 2MHz} \geq 500nH$$

In addition, $R_{ILIM2} = 40.2k$ reduces the peak current limit on channel 2 to 2.5A, which reduces inductor size and catch diode requirements.

APPLICATIONS INFORMATION

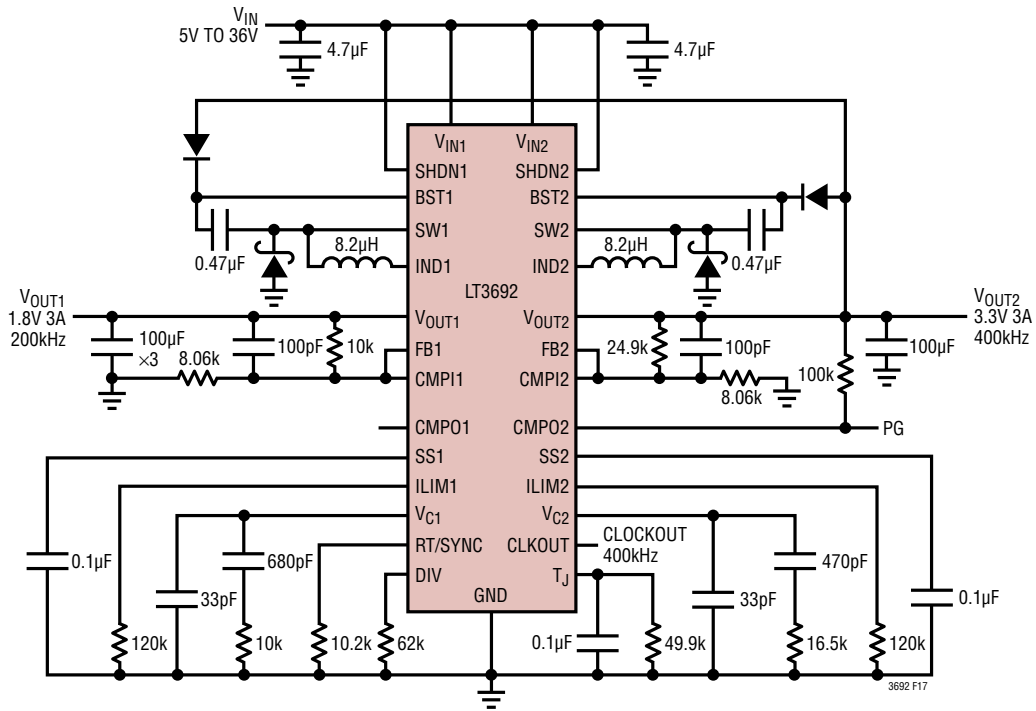

Figure 17. 3.3V and 1.8V Dual Step-Down Multi-Frequency Converter

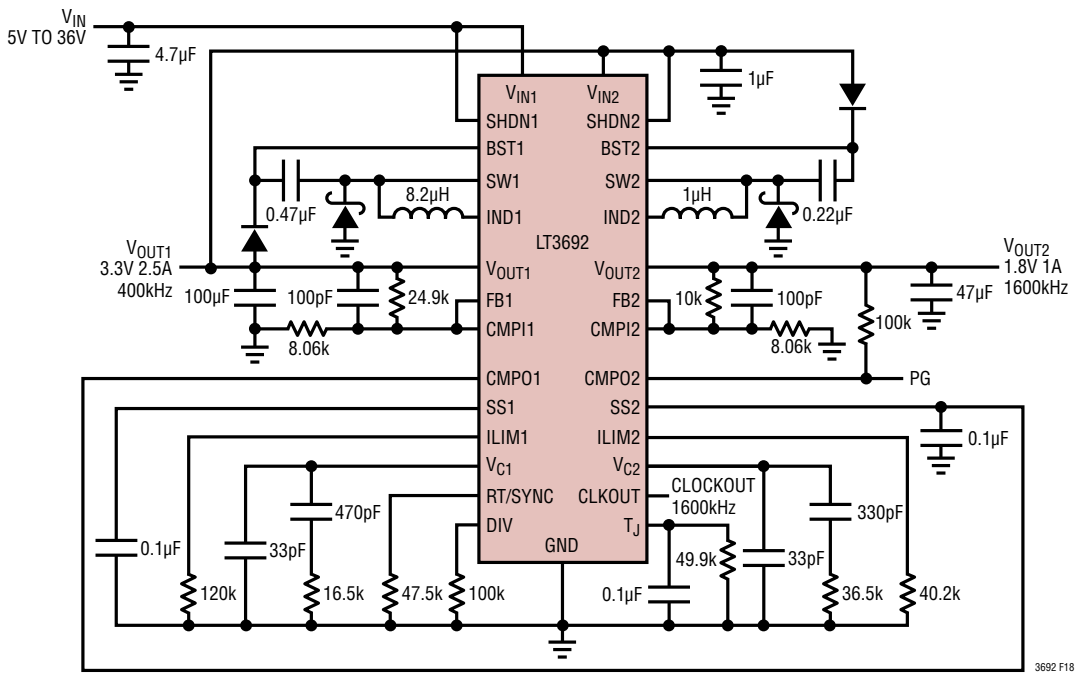

Figure 18. 3.3V and 1.8V 2-Stage Dual Step-Down Multi-Frequency Converter

APPLICATIONS INFORMATION

Shorted and Reverse Input Protection

If the inductor is chosen so that it won't saturate excessively, an LT3692 step-down regulator will tolerate a shorted output. There is another situation to consider in systems where the output will be held high when the input to the LT3692 is absent. This may occur in battery charging applications or in battery back-up systems where a battery or some other supply is diode OR-ed with the LT3692's output. If the $V_{IN1/2}$ pin is allowed to float and the SHDN pin is held high (either by a logic signal or because it is tied to V_{IN}), then the LT3692's internal circuitry will pull its quiescent current through its SW pin. This is fine if your system can tolerate a few mA in this state. If you ground the SHDN pin, the SW pin current will drop to essentially zero. However, if the V_{IN} pin is grounded while the output is held high, then parasitic diodes inside the LT3692 can pull large currents from the output through the SW pin and the $V_{IN1/2}$ pin. Figure 19 shows a circuit that will run only when the input voltage is present and that protects against a shorted or reversed input.

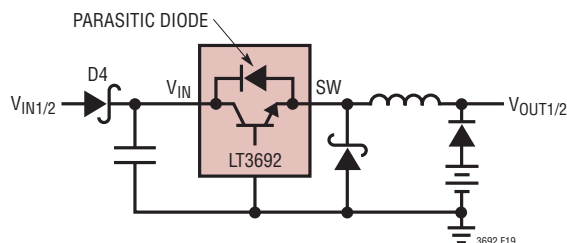

Figure 19. Diode D4 Prevents a Shorted Input from Discharging a Backup Battery Tied to the Output

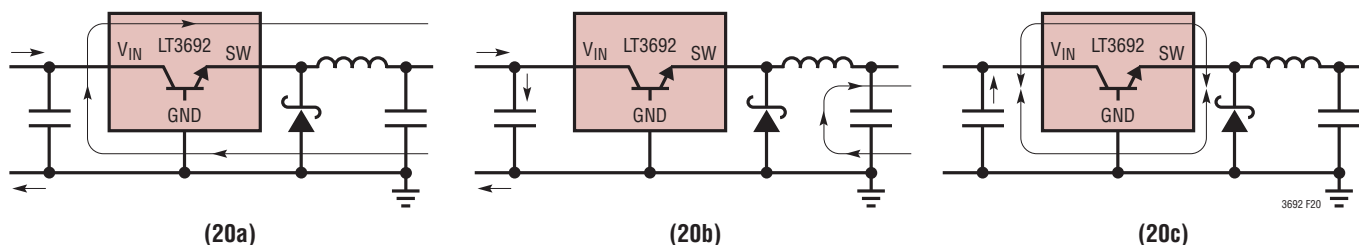

Figure 20. Subtracting the Current when the Switch is On (20a) from the Current when the Switch is Off (20b) Reveals the Path of the High Frequency Switching Current (20c). Keep this Loop Small. The Voltage on the SW and BST Traces will Also Be Switched; Keep These Traces as Short as Possible. Finally, Make Sure the Circuit is Shielded with a Local Ground Plane

PCB Layout

For proper operation and minimum EMI, care must be taken during printed circuit board (PCB) layout. Figure 20 shows the high di/dt paths in the buck regulator circuit. Note that large switched currents flow in the power switch, the catch diode and the input capacitor. The loop formed by these components should be as small as possible.

These components, along with the inductor and output capacitor, should be placed on the same side of the circuit board and their connections should be made on that layer. Place a local, unbroken ground plane below these components, and tie this ground plane to system ground at one location, ideally at the ground terminal of the output capacitor C2. Additionally, the SW and BST traces should be kept as short as possible.

Thermal Considerations

The PCB must also provide heat sinking to keep the LT3692 cool. The exposed metal on the bottom of the package must be soldered to a ground plane. This ground should be tied to other copper layers below with thermal vias; these layers will spread the heat dissipated by the LT3692. Place additional vias near the catch diodes. Adding more copper to the top and bottom layers and tying this copper to the internal planes with vias can further reduce thermal resistance. With these steps, the thermal resistance from die (or junction) to ambient can be reduced to $\theta_{JA} = 35^{\circ}\text{C}/\text{W}$.

APPLICATIONS INFORMATION

The power dissipation in the other power components such as catch diodes, boost diodes and inductors, cause additional copper heating and can further increase what the IC sees as ambient temperature. See the LT1767 data sheet's Thermal Considerations section.

Die Temperature and Thermal Shutdown

The LT3692 T_J pin outputs a voltage proportional to the internal junction temperature. The T_J pin typically outputs 250mV for 25°C and has a slope of 10mV/°C. Without the aid of external circuitry, the T_J pin output is valid from 20°C to 150°C (200mV to 1.5V) with a maximum load of 100µA.

Full Temperature Range Measurement

To extend the operating temperature range of the T_J output below 20°C, connect a resistor from the T_J pin to a negative supply as shown in Figure 21. The negative rail voltage and T_J pin resistor may be calculated using the following equations:

$$V_{NEG} \leq \frac{2 \cdot \text{TEMP(MIN)}^\circ\text{C}}{100}$$

$$R1 \leq \frac{|V_{NEG}|}{33\mu\text{A}}$$

where:

TEMP(MIN)°C is the minimum temperature where a valid T_J pin output is required.

V_{NEG} = Regulated negative voltage supply.

For example:

$$\text{TEMP(MIN)}^\circ\text{C} = -40^\circ\text{C}$$

$$V_{NEG} \leq -0.8\text{V}$$

$$V_{NEG} = -1, R1 \leq |V_{NEG}|/33\mu\text{A} = 30.2\text{k}\Omega$$

Generating a Negative Regulated Voltage

The simple charge pump circuit in Figure 22 uses the CLKOUT pin output to generate a negative voltage, eliminating the need for an external regulated supply. Surface mount capacitors and dual-package Schottky diodes minimize the board area needed to implement the negative voltage supply.

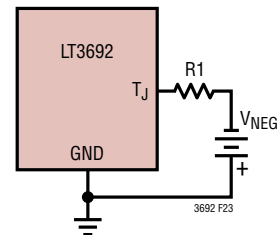

Figure 21. Circuit to Extend the T_J Pin Operating Range

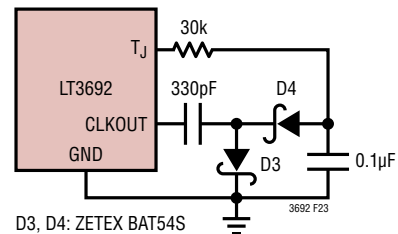

Figure 22. Circuit to Generate the Negative Voltage Rail to Extend the T_J Pin Operating Range

APPLICATIONS INFORMATION

As a safeguard, the LT3692 has an additional thermal shutdown threshold set at a typical value of 163°C for each channel. Each time the threshold is exceeded, a power on sequence for that channel will be initiated. The sequence will then repeat until the thermal overload is removed.

It should be noted that the T_J pin voltage represents a steady-state temperature and should not be used to guarantee that maximum junction temperatures are not exceeded. Instantaneous power along with thermal gradients and time constants may cause portions of the die to exceed maximum ratings and thermal shutdown thresholds. Be sure to calculate die temperature rise for steady state (>1Min) as well as impulse conditions.

CLKOUT Capacitive Loading

A minor drawback to generating a negative rail from the CLKOUT pin is that the charge pump adds capacitance to the CLKOUT pin, resulting in an output synchronization

clock signal phase delay. Figures 23 and 24 show the impact of capacitive loading on the CLKOUT signal rise and fall times. Note that a typical 10:1 150MHz oscilloscope probe contributes significant capacitance to the CLKOUT node, necessitating a low capacitance probe for accurate measurements. Applications requiring CLKOUT to generate the negative supply voltage and provide the synchronization clock to other regulators may benefit from buffering CLKOUT prior to the charge pump circuitry.

Other Linear Technology Publications

Application notes AN19, AN35 and AN44 contain more detailed descriptions and design information for buck regulators and other switching regulators. The LT1376 data sheet has a more extensive discussion of output ripple, loop compensation and stability testing. Design Note DN100 shows how to generate a dual (+ and -) output supply using a buck regulator.

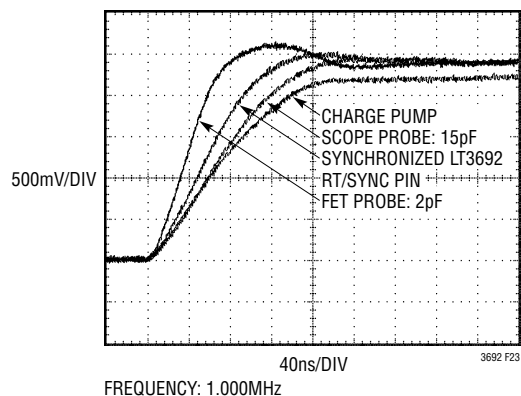

Figure 23. CLKOUT Rise Time

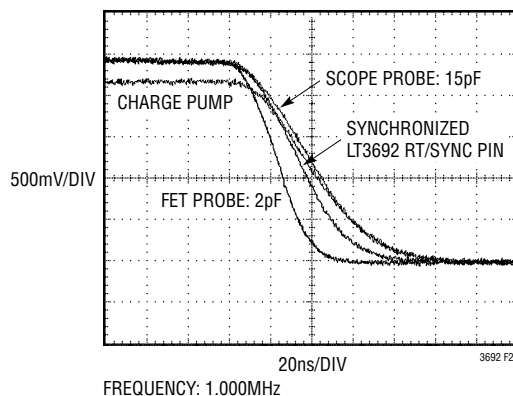
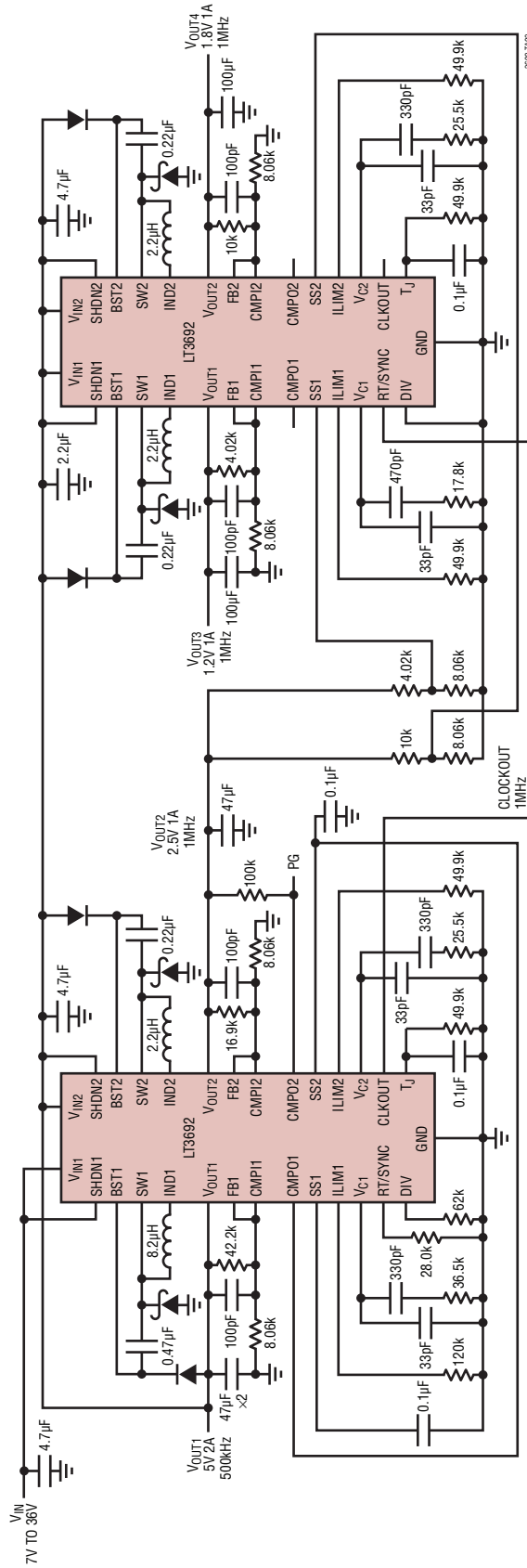

Figure 24. CLKOUT Fall Time

TYPICAL APPLICATIONS

Quad Output 5V, 2.5V, 1.8V and 2V Multi-Frequency Synchronized, 2-Stage Converter with Output Sequencing, Absolute Tracking and Current Limiting



TYPICAL APPLICATIONS

3.3V and 1.8V 2-Stage Dual Step-Down Multi-Frequency Converter

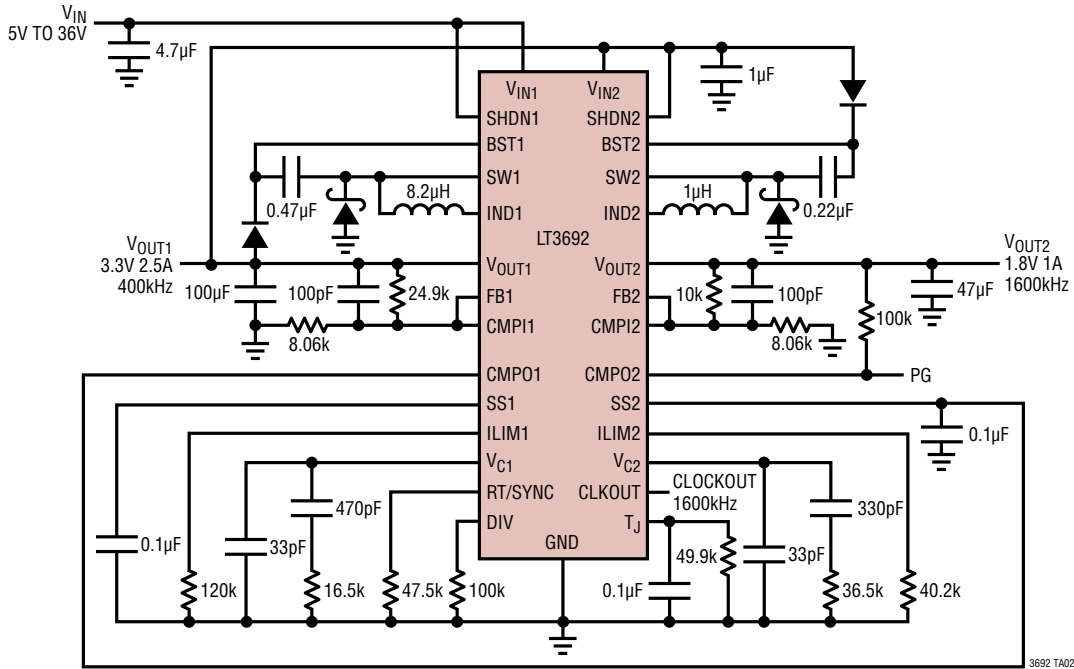

12V to 3.3V and 2.5V Converter with Start-Up Current Limiting

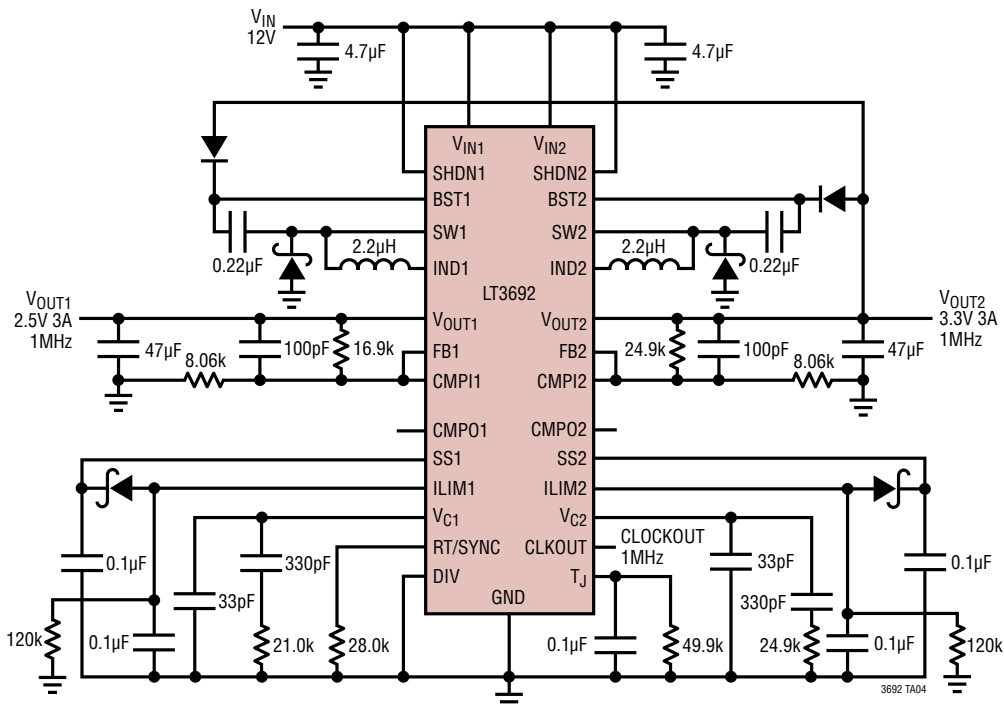

TYPICAL APPLICATIONS

3.3V/6A Single Output with UVLO and 100°C Temperature Warning

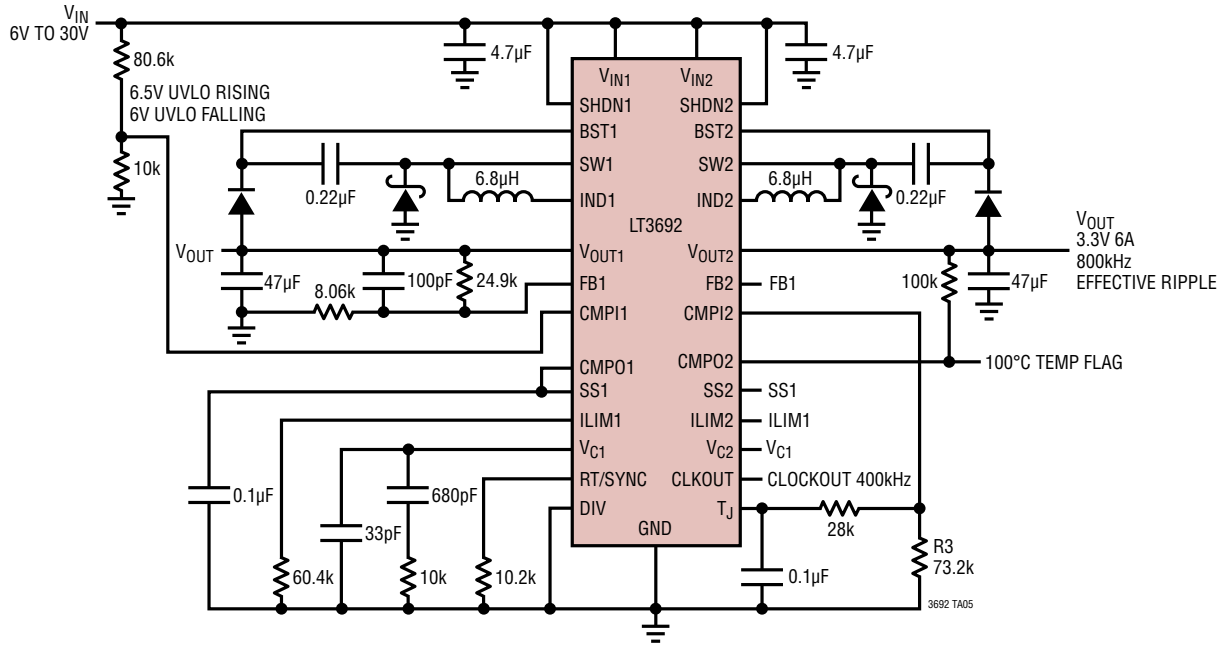

TYPICAL APPLICATIONS

Power Supply Dual Input Single 3.3V/4A Output Step-Down Converter

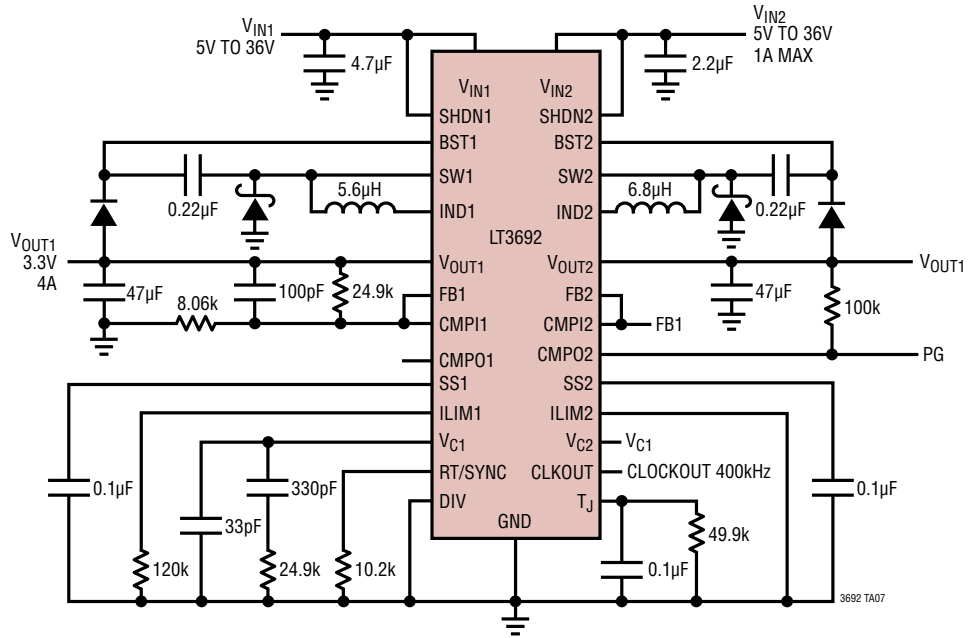

TYPICAL APPLICATIONS

5V and 1.8V Dual 2-Stage Converter

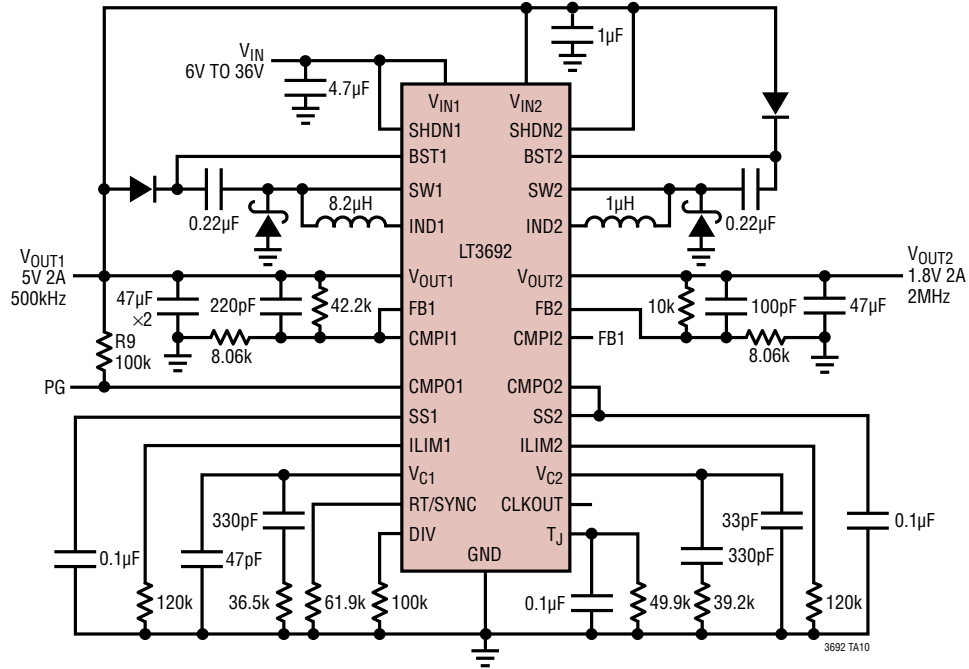

TYPICAL APPLICATIONS

12V, 3.3V, 2.5V, 1.2V Quad Output with External Synchronization, Output Sequencing and Tracking Application

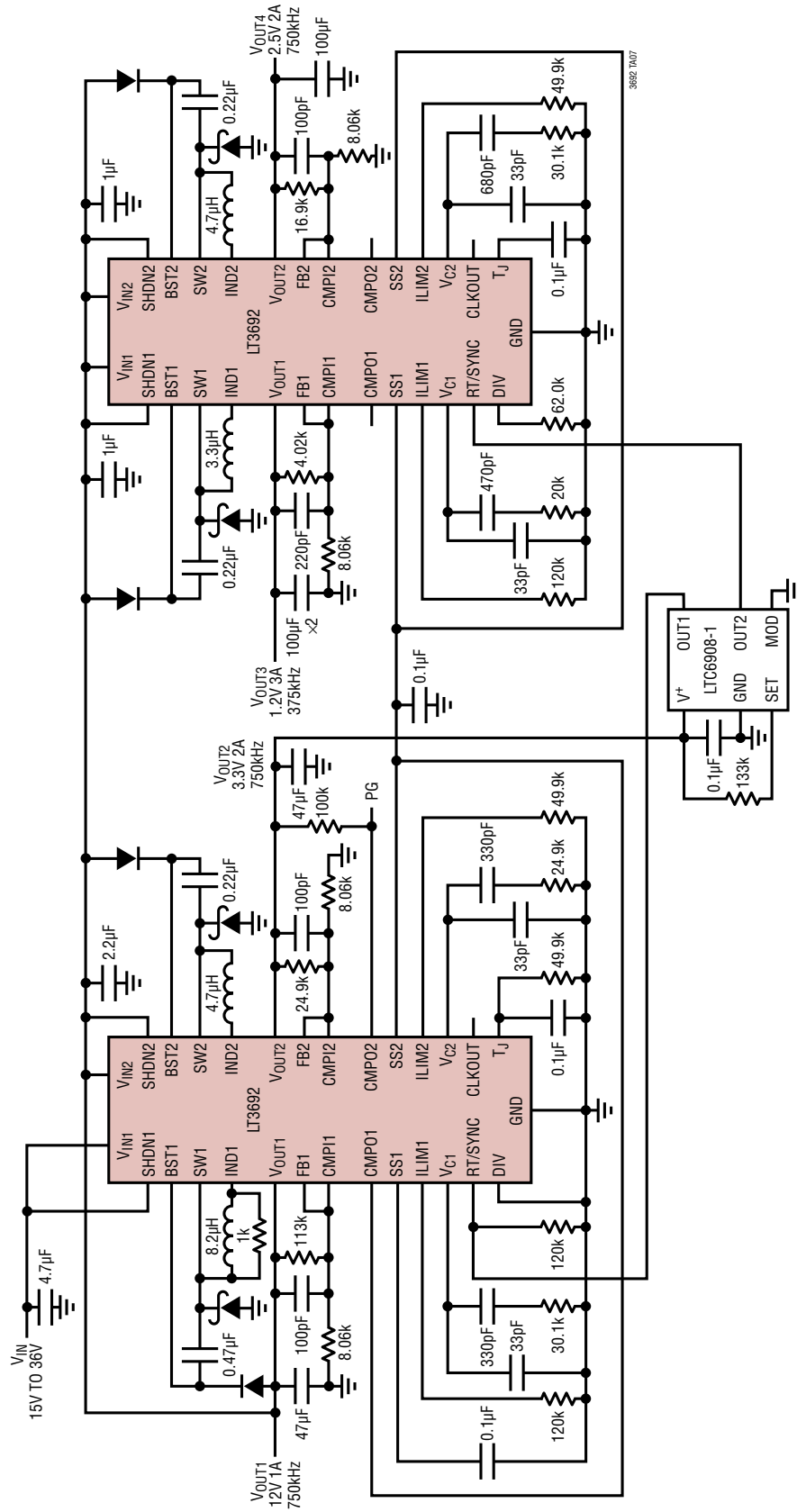

TYPICAL APPLICATIONS

5V, 3.3V, 2.5V, 1.8V Synchronized Quad Output

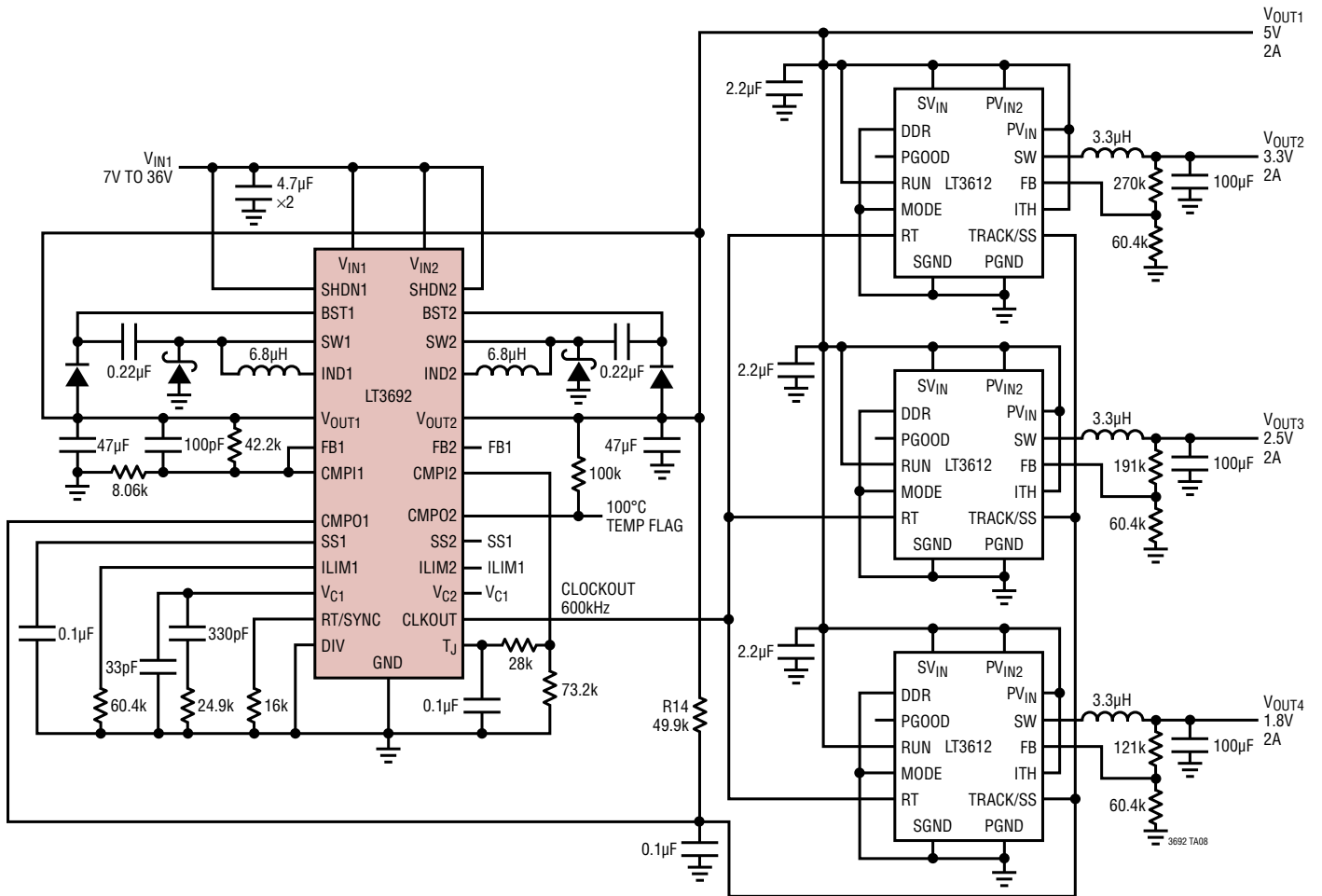

PACKAGE DESCRIPTION

UH Package
32-Lead Plastic QFN (5mm × 5mm)
 (Reference LTC DWG # 05-08-1693 Rev D)

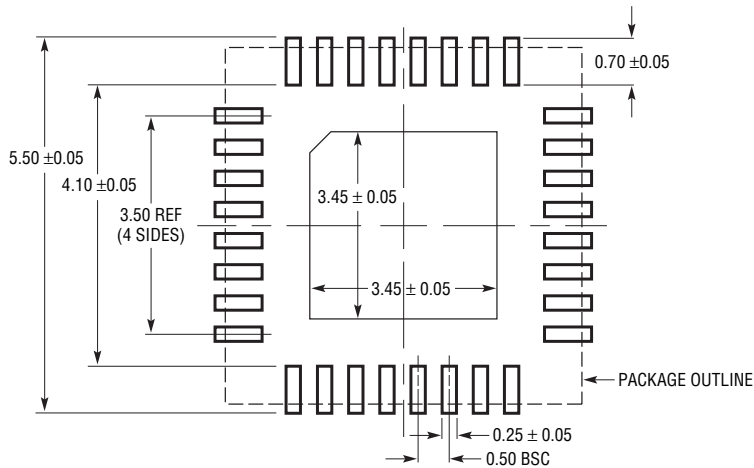

RECOMMENDED SOLDER PAD LAYOUT
 APPLY SOLDER MASK TO AREAS THAT ARE NOT SOLDERED

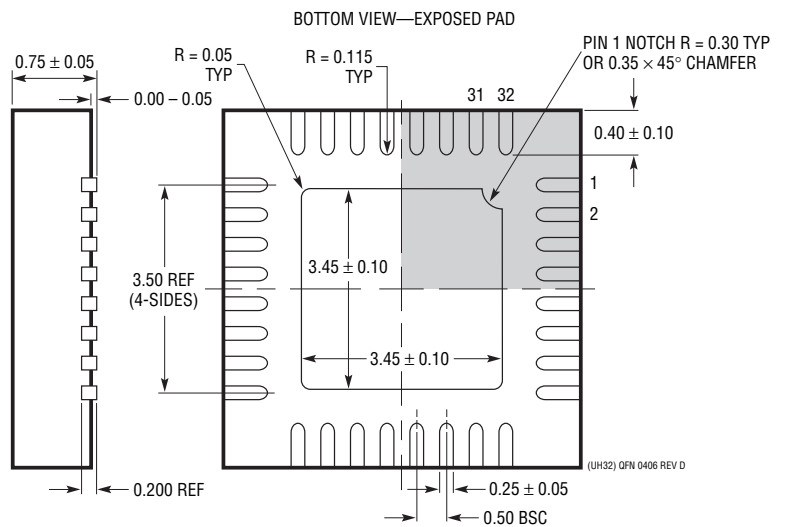
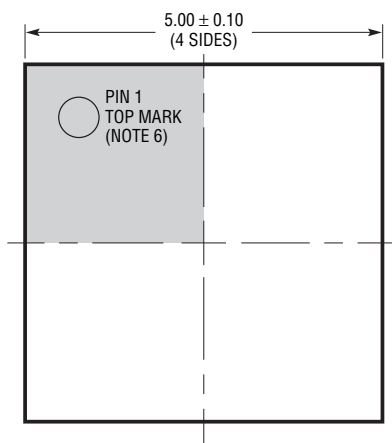

- NOTE:
1. DRAWING PROPOSED TO BE A JEDEC PACKAGE OUTLINE MO-220 VARIATION WHHD-(X) (TO BE APPROVED)
 2. DRAWING NOT TO SCALE
 3. ALL DIMENSIONS ARE IN MILLIMETERS
 4. DIMENSIONS OF EXPOSED PAD ON BOTTOM OF PACKAGE DO NOT INCLUDE MOLD FLASH. MOLD FLASH, IF PRESENT, SHALL NOT EXCEED 0.20mm ON ANY SIDE
 5. EXPOSED PAD SHALL BE SOLDER PLATED
 6. SHADED AREA IS ONLY A REFERENCE FOR PIN 1 LOCATION ON THE TOP AND BOTTOM OF PACKAGE

TYPICAL APPLICATION

1.2MHz, 12V to 3.3V at 3A, 5V at 3A

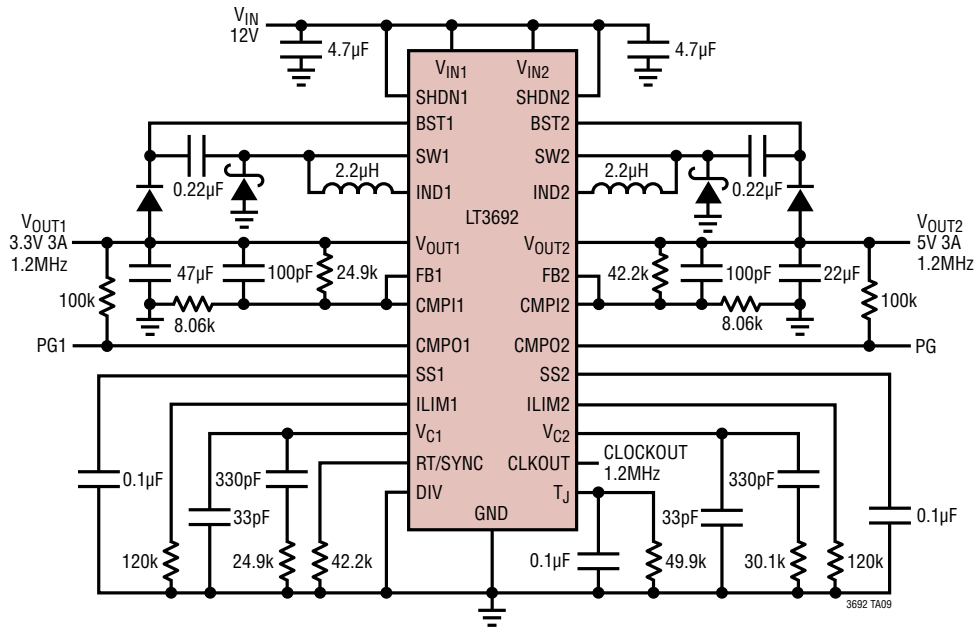

RELATED PARTS

PART	DESCRIPTION	COMMENTS
LT3507	36V, Triple 2.4A, 1.4A and 1.4A (I _{OUT}), 2.5MHz, High Efficiency Step-Down DC/DC Converter with LDO Controller	V _{IN} : 4V to 36V, V _{OUT(MIN)} = 0.8V, I _Q = 7mA, I _{SD} = 1µA, (5mm × 7mm) QFN-38
LT3508	36V with Transient Protection to 40V, Dual 1.4A (I _{OUT}), 3MHz, High Efficiency Step-Down DC/DC Converter	V _{IN} : 3.7V to 37V, V _{OUT(MIN)} = 0.8V, I _Q = 4.6mA, I _{SD} = 1µA, (4mm × 4mm) QFN-24, TSSOP-16E
LT3680	36V, 3A, 2.4MHz High Efficiency Micropower Step-Down DC/DC Converter	V _{IN} : 3.6V to 36V, V _{OUT(MIN)} = 0.8V, I _Q = 75µA, I _{SD} < 1µA, (3mm × 3mm) DFN-10, MSOP-10E
LT3693	36V, 3A, 2.4MHz High Efficiency Step-Down DC/DC Converter	V _{IN} : 3.6V to 36V, V _{OUT(MIN)} = 0.8V, I _Q = 1.3mA, I _{SD} < 1µA, (3mm × 3mm) DFN-10, MSOP-10E
LT3480	36V with Transient Protection to 60V, 2A (I _{OUT}), 2.4MHz, High Efficiency Step-Down DC/DC Converter with Burst Mode [®] Operation	V _{IN} : 3.6V to 38V, Transients to 60V, V _{OUT(MIN)} = 0.78V, I _Q = 70µA, I _{SD} < 1µA, (3mm × 3mm) DFN-10, MSOP-10E
LT3980	58V with Transient Protection to 80V, 2A (I _{OUT}), 2.4MHz, High Efficiency Step-Down DC/DC Converter with Burst Mode Operation	V _{IN} : 3.6V to 58V, Transients to 80V, V _{OUT(MIN)} = 0.79V, I _Q = 75µA, I _{SD} < 1µA, (3mm × 4mm) DFN-16, MSOP-16E
LT3971	38V, 1.2A (I _{OUT}), 2MHz, High Efficiency Step-Down DC/DC Converter with Only 2.8µA of Quiescent Current	V _{IN} : 4.2V to 38V, V _{OUT(MIN)} = 1.2V, I _Q = 2.8µA, I _{SD} < 1µA, (3mm × 3mm) DFN-10, MSOP-10E
LT3991	55V, 1.2A (I _{OUT}), 2MHz, High Efficiency Step-Down DC/DC Converter with Only 2.8µA of Quiescent Current	V _{IN} : 4.2V to 55V, V _{OUT(MIN)} = 1.2V, I _Q = 2.8µA, I _{SD} < 1µA, (3mm × 3mm) DFN-10, MSOP-10E