

## FEATURES

- **6A, 42V Combined Power Switch**
- **Output Short Circuit Protection**
- **Wide Input Range: 2.5V to 16V Operating, 40V Maximum Transient**
- **LT3579-1: Dual-Phase Capable**
- Master/Slave (3.4A/2.6A) Switch Design
- User Configurable Undervoltage Lockout
- Easily Configurable as a Boost, SEPIC, Inverting, or Flyback Converter
- Low  $V_{CESAT}$  Switch: 250mV at 5.5A (Typical)
- Can be Synchronized to External Clock
- Can Synchronize other Switching Regulators
- High Gain  $\overline{SHDN}$  Pin Accepts Slowly Varying Input Signals
- 20-Lead TSSOP and 20-Pin 4mm × 5mm QFN Packages

## APPLICATIONS

- Local Power Supply
- Vacuum Fluorescent Display (VFD) Bias Supplies
- TFT-LCD Bias Supplies
- Automotive Engine Control Unit (ECU) Power

LT, LT, LTC, LTM, Linear Technology and the Linear logo are registered trademarks of Linear Technology Corporation. All other trademarks are the property of their respective owners. Protected by U.S. Patents, including 7579816.

## DESCRIPTION

The LT<sup>®</sup>3579 is a PWM DC/DC converter with built-in fault protection features to aid in protecting against output shorts, input/output overvoltage, and overtemperature conditions. The part consists of a 42V master switch, and a 42V slave switch that can be tied together for a total current limit of 6A.

The LT3579 is ideal for many local power supply designs. It can be easily configured in Boost, SEPIC, Inverting, or Flyback configurations, and is capable of generating 12V at 1.7A, or -12V at 1.2A from a 5V input. In addition, the LT3579's slave switch allows the part to be configured in high voltage, high power charge pump topologies that are very efficient and require fewer components than traditional circuits.

The LT3579's switching frequency range can be set between 200kHz and 2.5MHz. The part may be clocked internally at a frequency set by the resistor from the RT pin to ground, or it may be synchronized to an external clock. A buffered version of the clock signal is driven out of the CLKOUT pin, and may be used to synchronize other compatible switching regulator ICs to the LT3579.

The LT3579 also features innovative  $\overline{SHDN}$  pin circuitry that allows for slowly varying input signals and an adjustable undervoltage lockout function. Additional features such as frequency foldback and soft-start are integrated. The LT3579 is available in 20-lead TSSOP and 20-pin 4mm × 5mm QFN packages.

## TYPICAL APPLICATION

**1MHz, 5V to 12V Boost Converter with Output Short Circuit Protection**

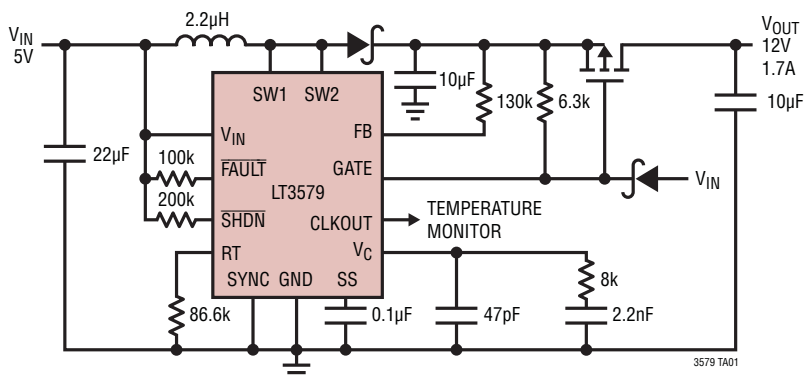

**Efficiency and Power Loss**

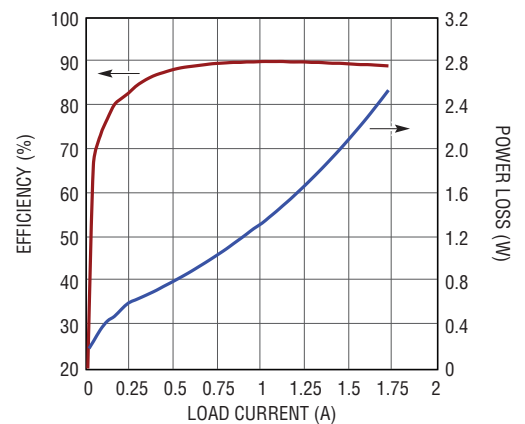

# LT3579/LT3579-1

## ABSOLUTE MAXIMUM RATINGS

(Note 1)

$V_{IN}$ Voltage	-0.3V to 40V	$\overline{FAULT}$	-0.3V to 40V
SW1/SW2 Voltage	-0.4V to 42V	$\overline{FAULT}$ Current	$\pm 0.5mA$
$R_T$ Voltage	-0.3V to 5V	CLKOUT	-0.3V to 3V
SS, FB Voltage	-0.3V to 2.5V	CLKOUT Current	$\pm 1mA$
$V_C$ Voltage	-0.3V to 2V	Operating Junction Temperature Range	
SHDN Voltage	-0.3V to 40V	LT3579E (Notes 2, 4)	-40°C to 125°C
SYNC Voltage	-0.3V to 5.5V	LT3579I (Notes 2, 4)	-40°C to 125°C
GATE Voltage	-0.3V to 80V	Storage Temperature Range	
			-65°C to 150°C

## PIN CONFIGURATION

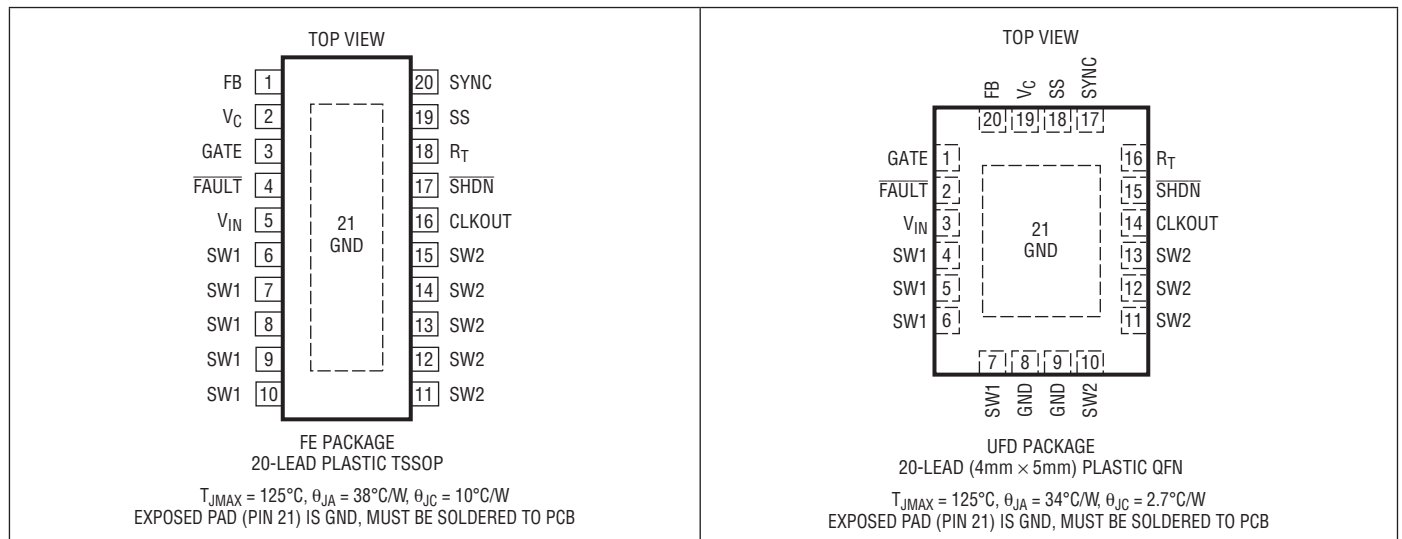

## ORDER INFORMATION

LEAD FREE FINISH	TAPE AND REEL	PART MARKING*	PACKAGE DESCRIPTION	TEMPERATURE RANGE
LT3579EFE#PBF	LT3579EFE#TRPBF	LT3579FE	20-Lead Plastic TSSOP	-40°C to 125°C
LT3579IFE#PBF	LT3579IFE#TRPBF	LT3579FE	20-Lead Plastic TSSOP	-40°C to 125°C
LT3579EUF#PBF	LT3579EUF#TRPBF	3579	20-Lead (4mm x 5mm) Plastic QFN	-40°C to 125°C
LT3579IUF#PBF	LT3579IUF#TRPBF	3579	20-Lead (4mm x 5mm) Plastic QFN	-40°C to 125°C
LT3579EFE-1#PBF	LT3579EFE-1#TRPBF	LT3579FE-1	20-Lead Plastic TSSOP	-40°C to 125°C
LT3579IFE-1#PBF	LT3579IFE-1#TRPBF	LT3579FE-1	20-Lead Plastic TSSOP	-40°C to 125°C
LT3579EUF-1#PBF	LT3579EUF-1#TRPBF	35791	20-Lead (4mm x 5mm) Plastic QFN	-40°C to 125°C
LT3579IUF-1#PBF	LT3579IUF-1#TRPBF	35791	20-Lead (4mm x 5mm) Plastic QFN	-40°C to 125°C

Consult LTC Marketing for parts specified with wider operating temperature ranges. \*The temperature grade is identified by a label on the shipping container.

For more information on lead free part marking, go to: <http://www.linear.com/leadfree/>

For more information on tape and reel specifications, go to: <http://www.linear.com/tapeandreeel/>

**ELECTRICAL CHARACTERISTICS** The ● denotes the specifications which apply over the full operating temperature range, otherwise specifications are at  $T_A = 25^\circ\text{C}$ .  $V_{IN} = 5\text{V}$ ,  $V_{SHDN} = V_{IN}$ ,  $V_{FAULT} = V_{IN}$  unless otherwise noted. (Note 2).

PARAMETER	CONDITIONS		MIN	TYP	MAX	UNITS
Minimum Input Voltage		●		2.3	2.5	V
$V_{IN}$ Overvoltage Lockout			16.2	18.7	21.2	V
Positive Feedback Voltage		●	1.195	1.215	1.230	V
Negative Feedback Voltage		●	3	9	16	mV
Positive FB Pin Bias Current	$V_{FB}$ =Positive Feedback Voltage, Current into Pin	●	80.5	83.3	85	$\mu\text{A}$
Negative FB Pin Bias Current	$V_{FB}$ =Negative Feedback Voltage, Current out of Pin	●	81	83.3	85.5	$\mu\text{A}$
Error Amp Transconductance	$\Delta I = 10\mu\text{A}$			250		$\mu\text{mhos}$
Error Amp Voltage Gain				70		V/V
Quiescent Current	Not Switching			1.9	2.4	mA
Quiescent Current in Shutdown	$V_{SHDN} = 0\text{V}$			0	1	$\mu\text{A}$
Reference Line Regulation	$2.5\text{V} \leq V_{IN} \leq 15\text{V}$			0.01	0.05	%/V
Switching Frequency, $f_{OSC}$	$R_T = 34\text{k}\Omega$	●	2.2	2.5	2.8	MHz
	$R_T = 432\text{k}\Omega$	●	175	200	225	kHz
Switching Frequency in Foldback	Compared to Normal $f_{OSC}$			1/6		ratio
Switching Frequency Range	Free-Running or Synchronizing	●	200		2500	kHz
SYNC High Level for Sync		●	1.3			V
SYNC Low Level for Sync		●			0.4	V
SYNC Clock Pulse Duty Cycle	$V_{SYNC} = 0\text{V}$ to $2\text{V}$		20		80	%
Recommended Minimum SYNC Ratio $f_{SYNC}/f_{OSC}$				3/4		
Minimum Off-Time				45		nS
Minimum On-Time				55		nS
SW1 Current Limit	At All Duty Cycles (Note 3)	●	3.4	4.2	5.1	A
SW Current Sharing, $I_{SW2}/I_{SW1}$	SW1 and SW2 Tied Together			0.78		A/A
SW1 + SW2 Current Limit	$I_{SW2}/I_{SW1} = 0.78$ , At All Duty Cycles (Note 3)	●	6	7.5	9.4	A
Switch $V_{CESAT}$	SW1 and SW2 Tied Together, $I_{SW1} + I_{SW2} = 5.5\text{A}$			250	350	mV
SW1 Leakage Current	$V_{SW1} = 5\text{V}$			0.01	1	$\mu\text{A}$
SW2 Leakage Current	$V_{SW2} = 5\text{V}$			0.01	1	$\mu\text{A}$

## ELECTRICAL CHARACTERISTICS

The ● denotes the specifications which apply over the full operating temperature range, otherwise specifications are at  $T_A = 25^\circ\text{C}$ .  $V_{IN} = 5\text{V}$ ,  $V_{SHDN} = V_{IN}$ ,  $V_{FAULT} = V_{IN}$  unless otherwise noted. (Note 2).

PARAMETER	CONDITIONS		MIN	TYP	MAX	UNITS
Soft-Start Charge Current	$V_{SS} = 30\text{mV}$ , Current Flows Out of SS pin	●	5.7	8.7	11.3	$\mu\text{A}$
Soft-Start Discharge Current	Part in FAULT $V_{SS} = 2.1\text{V}$ , Current Flows into SS Pin	●	5.7	8.7	11.3	$\mu\text{A}$
Soft-Start High Detection Voltage	Part in FAULT	●	1.65	1.8	1.95	V
Soft-Start Low Detection Voltage	Part Exiting FAULT	●	30	50	85	mV
SHDN Minimum Input Voltage High	Active Mode, SHDN Rising Active Mode, SHDN Falling	●	1.27	1.33	1.41	V
		●	1.24	1.3	1.38	V
SHDN Input Voltage Low	Shutdown Mode	●			.3	V
SHDN Pin Bias Current	$V_{SHDN} = 3\text{V}$ $V_{SHDN} = 1.3\text{V}$ $V_{SHDN} = 0\text{V}$		9.5	40	60	$\mu\text{A}$
				11.4	13.4	$\mu\text{A}$
				0	0.1	$\mu\text{A}$
CLKOUT Output Voltage High	$C_{CLKOUT} = 50\text{pF}$		1.9	2.1	2.3	V
CLKOUT Output Voltage Low	$C_{CLKOUT} = 50\text{pF}$			100	200	mV
CLKOUT Duty Cycle	LT3579, $T_J = 25^\circ\text{C}$			42		%
	LT3579-1, All $T_J$			50		%
CLKOUT Rise Time	$C_{CLKOUT} = 50\text{pF}$			12		ns
CLKOUT Fall Time	$C_{CLKOUT} = 50\text{pF}$			8		ns
GATE Pull Down Current	$V_{GATE} = 3\text{V}$ $V_{GATE} = 80\text{V}$	●	800	933	1100	$\mu\text{A}$
		●	800	933	1100	$\mu\text{A}$
GATE Leakage Current	$V_{GATE} = 50\text{V}$ , GATE Off			0.01	1	$\mu\text{A}$
FAULT Output Voltage Low	100 $\mu\text{A}$ into FAULT Pin	●		150	300	mV
FAULT Leakage Current	$V_{FAULT} = 40\text{V}$ , FAULT Off			0.01	1	$\mu\text{A}$
FAULT Input Voltage Low Threshold		●	700	750	800	mV
FAULT Input Voltage High Threshold		●	950	1000	1050	mV

**Note 1:** Stresses beyond those listed under Absolute Maximum Ratings may cause permanent damage to the device. Exposure to any Absolute Maximum Rating condition for extended periods may affect device reliability and lifetime.

**Note 2:** The LT3579E is guaranteed to meet performance specifications from  $0^\circ\text{C}$  to  $125^\circ\text{C}$  junction temperature. Specifications over the  $-40^\circ\text{C}$  to  $125^\circ\text{C}$  operating junction temperature range are assured by design, characterization and correlation with statistical process controls. The LT3579I is guaranteed over the full  $-40^\circ\text{C}$  to  $125^\circ\text{C}$  operating junction temperature range.

**Note 3:** Current limit guaranteed by design and/or correlation to static test.

**Note 4:** This IC includes overtemperature protection that is intended to protect the device during momentary overload conditions. Junction temperature will exceed  $125^\circ\text{C}$  when overtemperature protection is active. Continuous operation over the specified maximum operating junction temperature may impair device reliability.

**TYPICAL PERFORMANCE CHARACTERISTICS**  $T_A = 25^\circ\text{C}$ , unless otherwise noted.

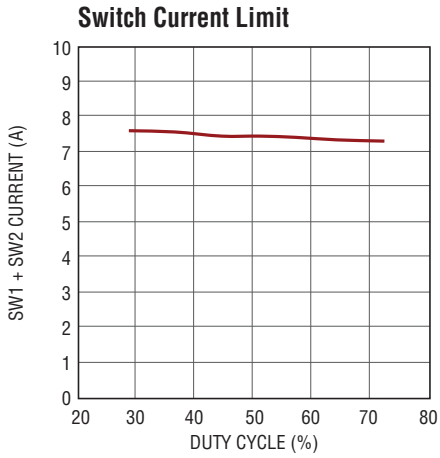

35791 G01

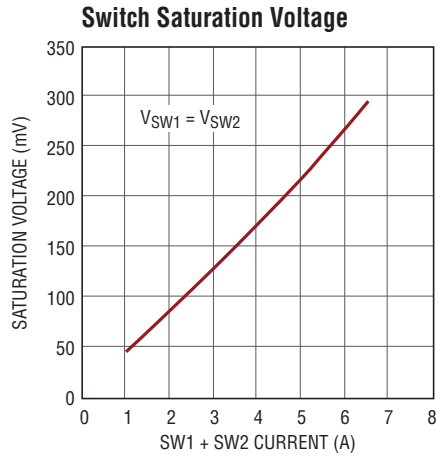

35791 G02

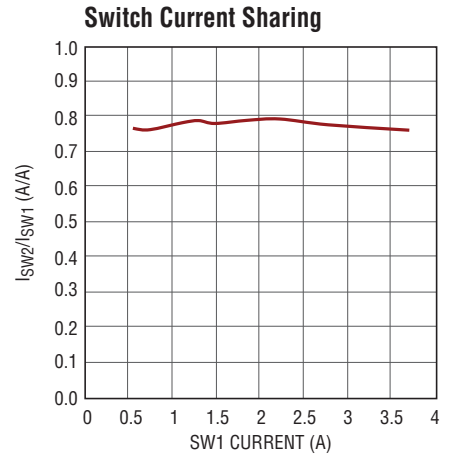

35791 G03

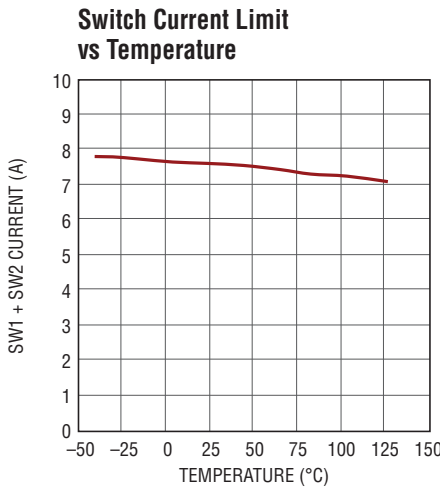

35791 G04

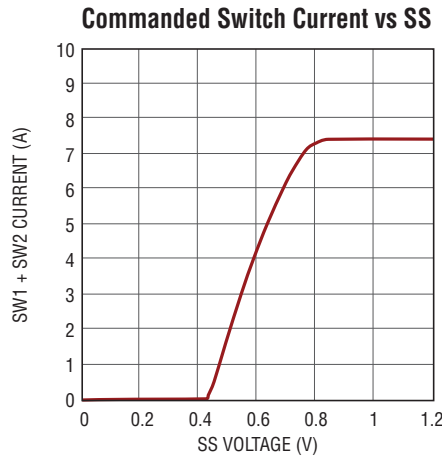

35791 G05

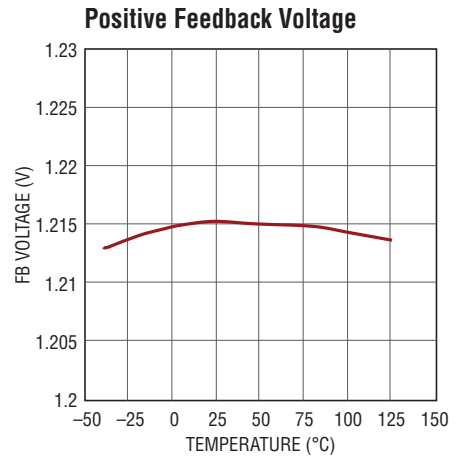

35791 G06

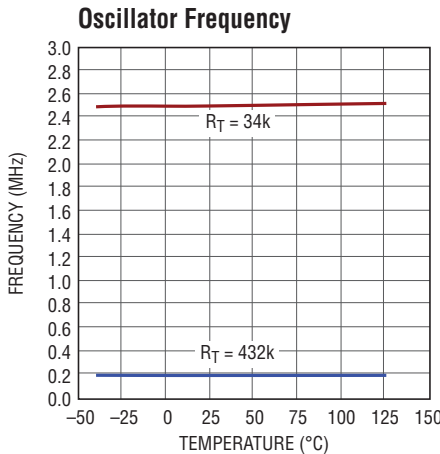

35791 G07

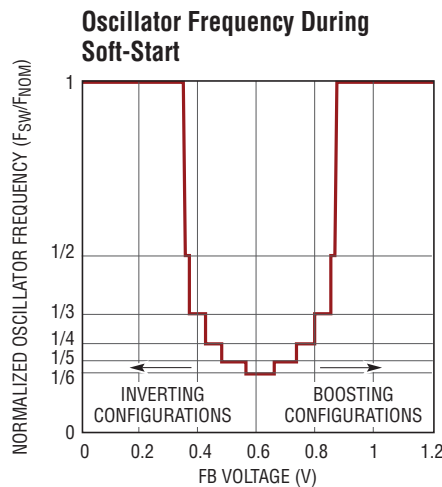

35791 G08

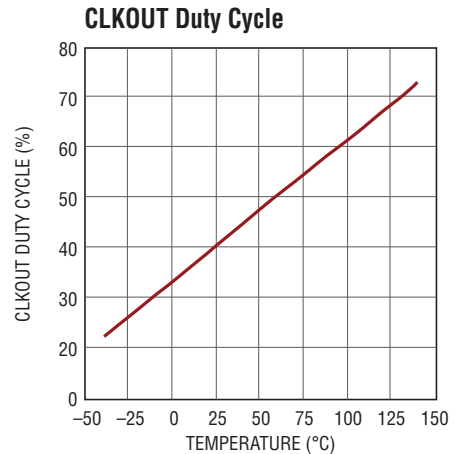

35791 G09

**TYPICAL PERFORMANCE CHARACTERISTICS**  $T_A = 25^\circ\text{C}$ , unless otherwise noted.

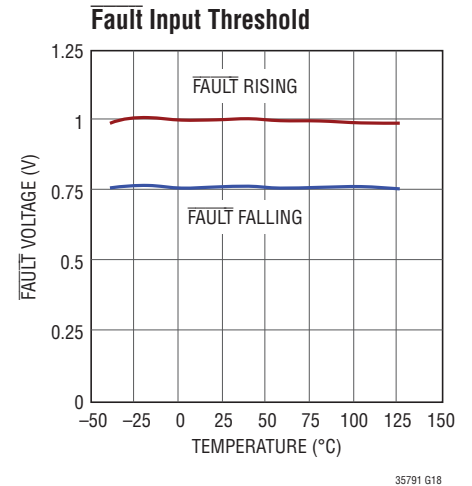
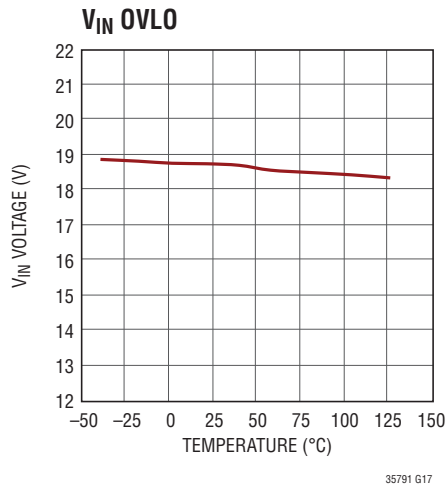
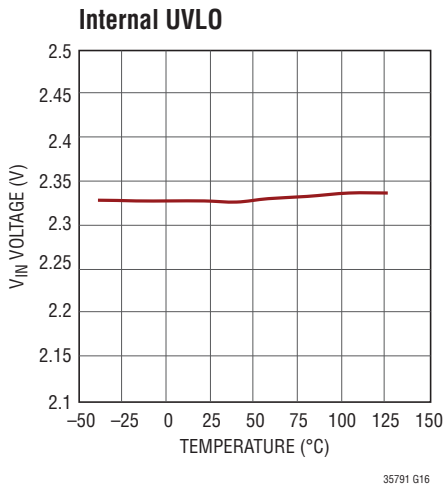
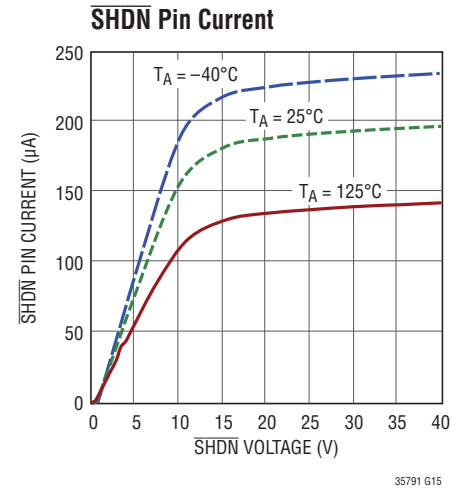
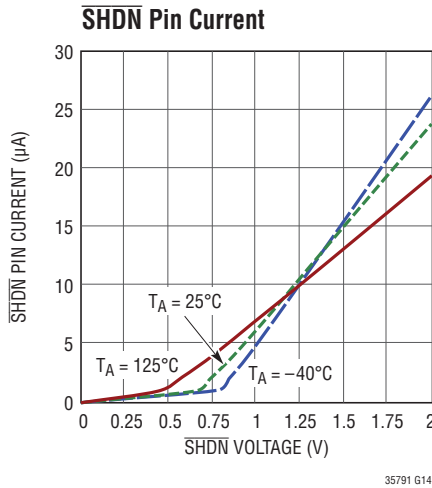
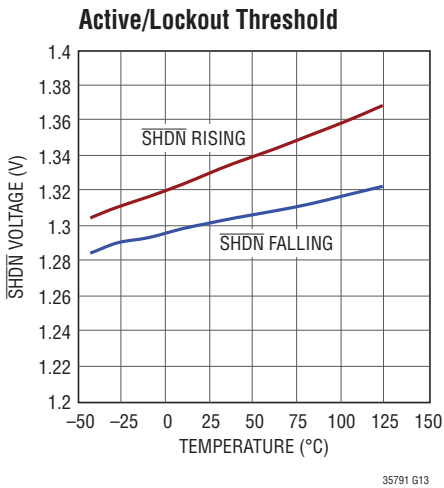
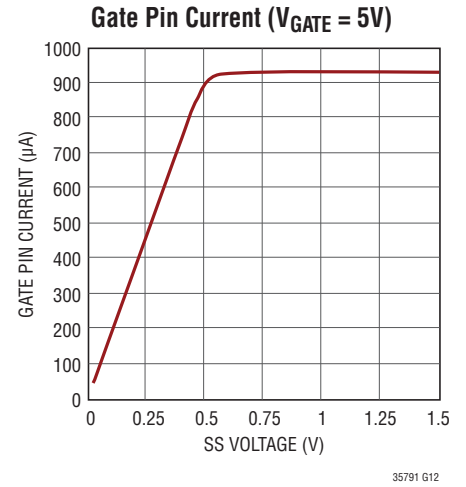
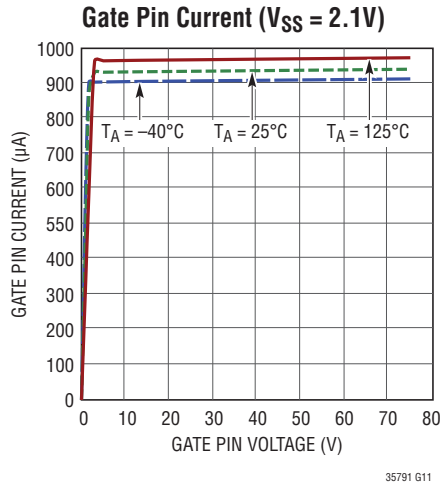
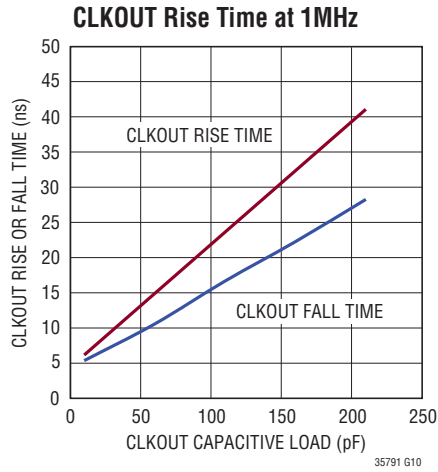

## PIN FUNCTIONS (QFN/TSSOP)

**GATE (Pin 1/Pin 3):** PMOS Gate Drive Pin. The GATE pin is a pull-down current source, and can be used to drive the gate of an external PMOS transistor for output short circuit protection or output disconnect. The GATE pin current increases linearly with the SS pin's voltage, with a maximum pull-down current of 933 $\mu$ A at SS voltages exceeding 500mV. Note that if the SS voltage is greater than 500mV, and the GATE pin voltage is less than 2V, the GATE pin looks like a 2k $\Omega$  impedance to ground. See the Appendix for more information.

**FAULT (Pin 2/Pin 4):** Fault Indication Pin. This active low, bidirectional pin can either be pulled low (below 750mV) by an external source, or internally by the chip to indicate a fault. When pulled low, this pin causes the power switches to turn off, the GATE pin to become high impedance, the CLKOUT pin to become disabled, and the SS pin to go through a charge/discharge sequence. The end/absence of a fault is indicated when the voltage on this pin exceeds 1V. A pull-up resistor or some other form of pull-up network needs to exist on this pin to pull it above 1V in the absence of a fault.

**V<sub>IN</sub> (Pin 3/Pin 5):** Input Supply Pin. Must be locally bypassed.

**SW1 (Pins 4 - 7/Pins 6 - 10):** Master Switch Pin. This is the collector of the internal master NPN power switch. SW1 is designed to handle a peak collector current of 3.4A (minimum). Minimize the metal trace area connected to this pin to minimize EMI.

**GND (Pins 8, 9, Exposed Pad Pin 21/Exposed Pad Pin 21):** Ground. Must be soldered directly to local ground plane.

**SW2 (Pins 10-13/Pins 11-15):** Slave Switch Pin. This is the collector of the internal slave NPN power switch. SW2 is designed to handle a peak collector current of 2.6A (minimum). Minimize the metal trace area connected to this pin to minimize EMI.

**CLKOUT (Pin 14/Pin 16):** Clock Output Pin. Use this pin to synchronize one or more other ICs to the LT3579. This pin oscillates at the same frequency as the internal oscillator of the part or as the SYNC pin. CLKOUT may also be used as

a temperature monitor since the CLKOUT pin's duty cycle varies linearly with the part's junction temperature. The CLKOUT pin signal of the LT3579-1 is 180° out of phase with the internal oscillator or SYNC pin, and the duty cycle is fixed at ~50%. The LT3579-1 is useful for multiphase switching regulators.

**SHDN (Pin 15/Pin 17):** Shutdown Pin. In conjunction with the UVLO (undervoltage lockout) circuit, this pin is used to enable/disable the chip and restart the soft-start sequence. Drive below 0.3V to disable the chip with very low quiescent current. Drive above 1.33V (typical) to activate the chip and restart the soft-start sequence. Do not float this pin.

**RT (Pin 16/Pin 18):** Timing Resistor Pin. Adjusts the LT3579's switching frequency. Place a resistor from this pin to ground to set the frequency to a fixed free running level. Do not float this pin.

**SYNC (Pin 17/Pin 20):** To synchronize the switching frequency to an outside clock, simply drive this pin with a clock. The high voltage level of the clock must exceed 1.3V, and the low level must be less than 0.4V. Drive this pin to less than 0.4V to revert to the internal free running clock. See the Applications Information section for more information.

**SS (Pin 18/Pin 19):** Soft-Start Pin. Place a soft-start capacitor here. Upon start-up, the SS pin will be charged by a (nominally) 250k $\Omega$  resistor to ~2.1V. During a fault, the SS pin will be slowly charged up and discharged as part of a timeout sequence.

**V<sub>C</sub> (Pin 19/Pin 2):** Error Amplifier Output Pin. Tie external compensation network to this pin.

**FB (Pin 20/Pin 1):** Positive and Negative Feedback Pin. For a Boost or Inverting Converter, tie a resistor from the FB pin to V<sub>OUT</sub> according to the following equations:

$$R_{FB} = \left( \frac{V_{OUT} - 1.215V}{83.3\mu A} \right); \text{ Boost or SEPIC Converter}$$

$$R_{FB} = \left( \frac{|V_{OUT}| + 9mV}{83.3\mu A} \right); \text{ Inverting Converter}$$

**BLOCK DIAGRAM**

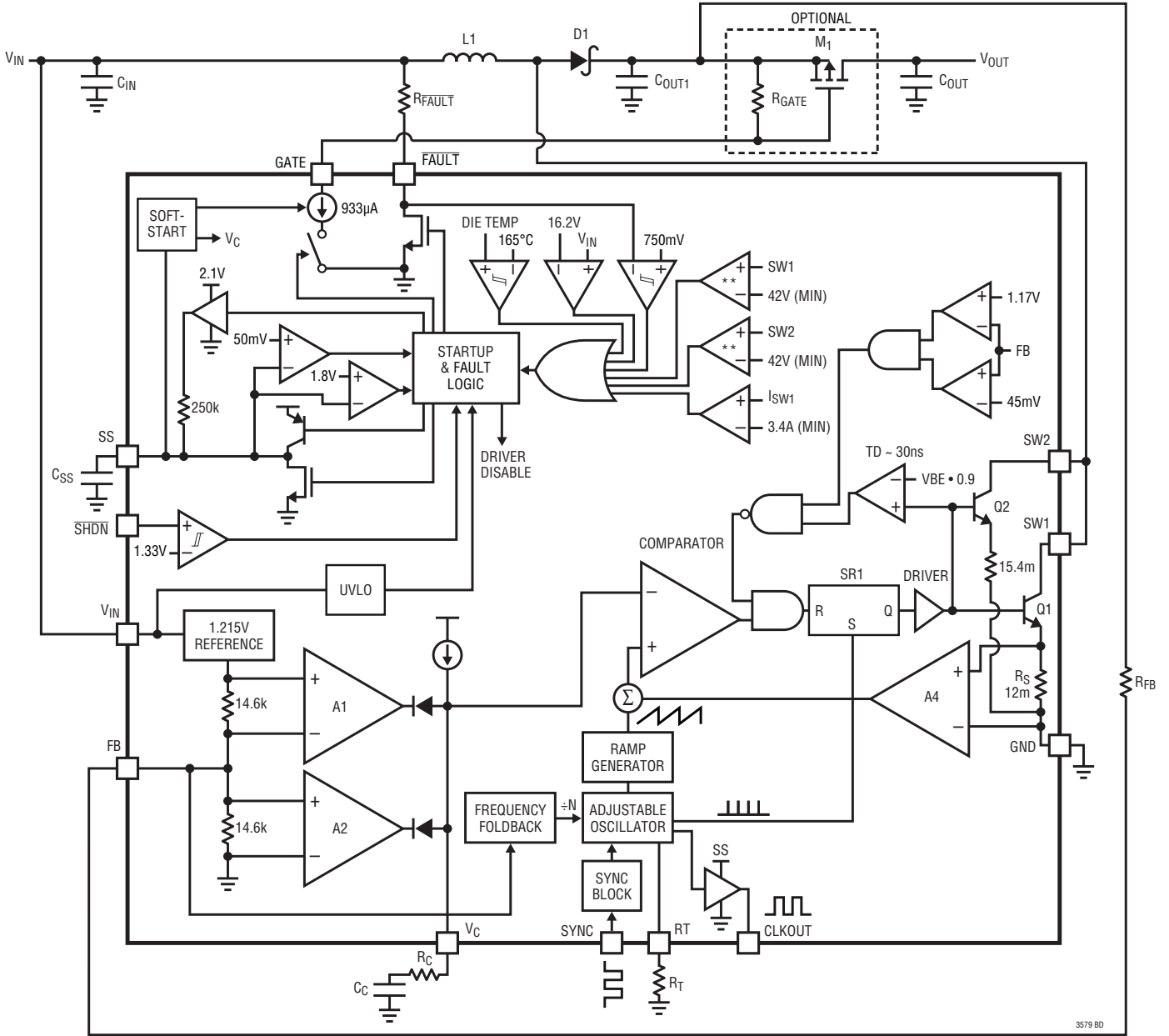

\*\* SW OVERVOLTAGE PROTECTION IS NOT GUARANTEED TO PROTECT THE LT3579/LT3579-1 DURING SW OVERVOLTAGE EVENTS.

Figure 1. Block Diagram



STATE DIAGRAM

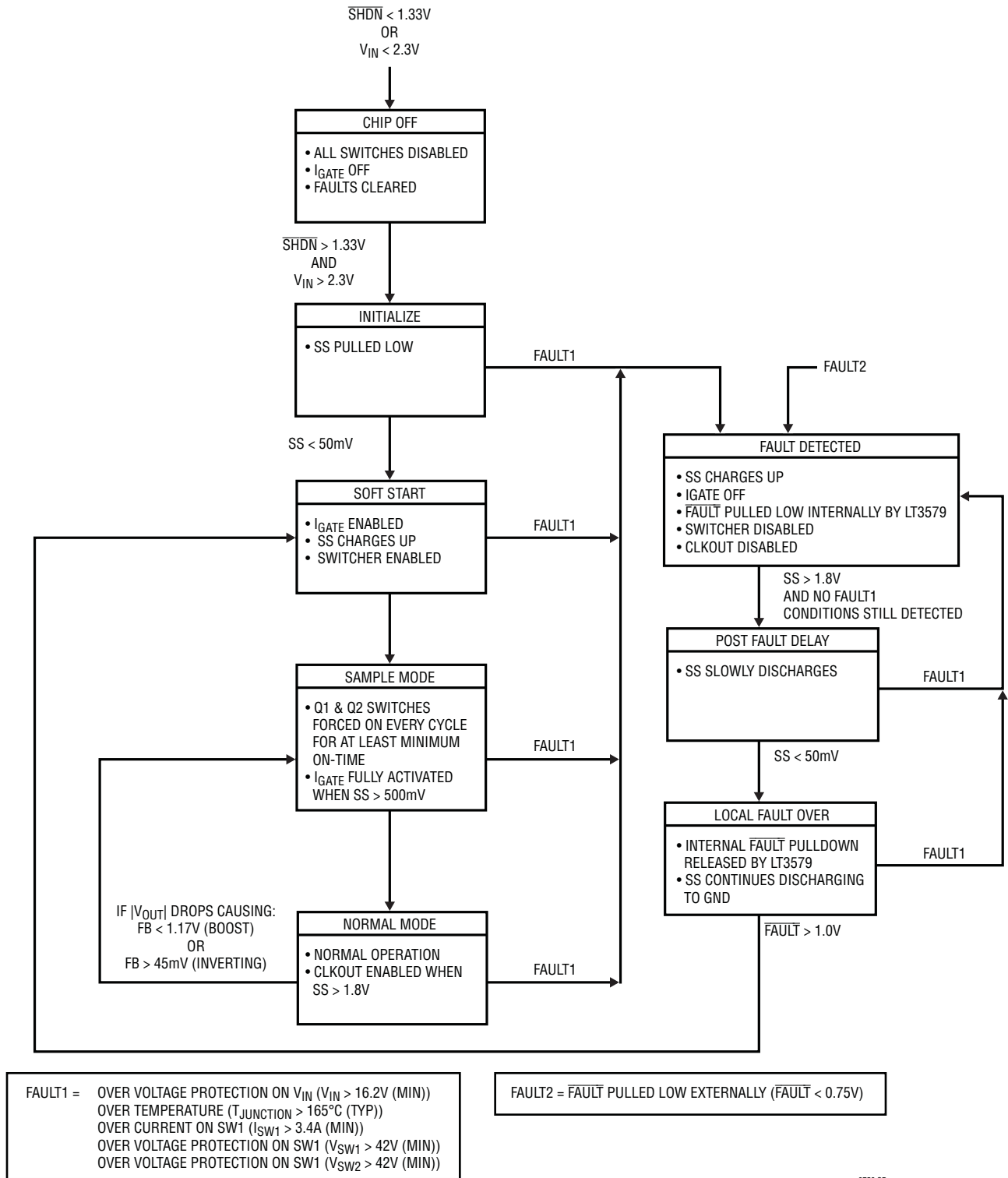

Figure 2. State Diagram

3759 SD

## OPERATION

### OPERATION – OVERVIEW

The LT3579 uses a constant-frequency, current mode control scheme to provide excellent line and load regulation. The part's undervoltage lockout (UVLO) function, together with soft-start and frequency foldback, offers a controlled means of starting up. Fault features are incorporated in the LT3579 to aid in the detection of output shorts, over-voltage, and overtemperature conditions. Refer to the Block Diagram (Figure 1) and the State Diagram (Figure 2) for the following description of the part's operation.

### OPERATION – START-UP

Several functions are provided to enable a very clean start-up for the LT3579.

#### Precise Turn-On Voltage

The  $\overline{\text{SHDN}}$  pin compares to an internal voltage reference to give a precise turn on voltage level. Taking the  $\overline{\text{SHDN}}$  pin above 1.33V (typical) enables the part. Taking the  $\overline{\text{SHDN}}$  pin below 0.3V shuts down the chip, resulting in extremely low quiescent current. The  $\overline{\text{SHDN}}$  pin has 30mV of hysteresis to protect against glitches and slow ramping.

#### Undervoltage-Lockout (UVLO)

The  $\overline{\text{SHDN}}$  pin can also be used to create a configurable UVLO. The UVLO function sets the turn on/off of the LT3579 at a desired input voltage ( $V_{\text{IN\_UVLO}}$ ). Figure 3 shows how a resistor divider (or single resistor) from  $V_{\text{IN}}$  to the  $\overline{\text{SHDN}}$  pin can be used to set  $V_{\text{IN\_UVLO}}$ .  $R_{\text{UVLO2}}$  is optional. It may be left out, in which case set it to infinite in the equation below. For increased accuracy, set  $R_{\text{UVLO2}} \leq 10\text{k}\Omega$ . Pick  $R_{\text{UVLO1}}$  as follows:

$$R_{\text{UVLO1}} = \frac{V_{\text{IN\_UVLO}} - 1.33\text{V}}{\left(\frac{1.33\text{V}}{R_{\text{UVLO2}}}\right) + 11.6\mu\text{A}}$$

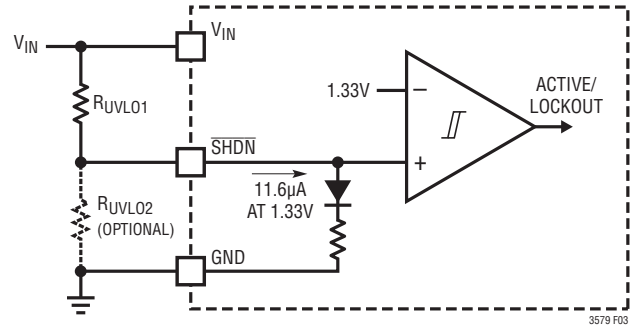

Figure 3. Configurable UVLO

The LT3579 also has internal UVLO circuitry that disables the chip when  $V_{\text{IN}} < 2.3\text{V}$  (typical).

#### Soft-Start of Switch Current

The soft-start circuitry provides for a gradual ramp-up of the switch current (refer to *Commanded Switch Current vs. SS* in Typical Performance Characteristics). When the part is brought out of shutdown, the external SS capacitor is first discharged which resets the states of the logic circuits in the chip. Then an integrated 250k resistor pulls the SS pin to  $\sim 1.8\text{V}$  at a ramp rate set by the external capacitor connected to the pin. Once SS gets to 1.8V, the CLKOUT pin is enabled, and an internal regulator pulls the pin up quickly to  $\sim 2.1\text{V}$ . Typical values for the external soft-start capacitor range from 100nF to 1µF.

#### Soft-Start of External PMOS (if used)

The soft-start circuitry also gradually ramps up the GATE pin pull-down current which allows an external PMOS to slowly turn on (M1 in Block Diagram). The GATE pin current increases linearly with SS voltage, with a maximum current of 933µA when the SS voltage gets above 500mV. Note that if the GATE pin voltage is less than 2V for SS voltages exceeding 500mV, then the GATE pin impedance to ground is 2kΩ. The soft turn on of the external PMOS helps limit inrush current at start-up, making hot plugs of the LT3579 feasible and safe.

## OPERATION

### Sample Mode

Sample Mode is the mechanism used by the LT3579 to aid in the detection of output shorts. It refers to a state of the LT3579 where the master and slave power switches (Q1 and Q2) are turned on for a minimum period of time every clock cycle (or every few clock cycles in frequency foldback) in order to “sample” the inductor current. If the sampled current through Q1 exceeds the master switch current limit of 3.4A (minimum), the LT3579 triggers an overcurrent fault internally (see Operation-Fault section for details). Sample Mode exists when FB is out of regulation by more than 3.7% or  $45\text{mV} < \text{FB} < 1.17\text{V}$  (typical). The LT3579's power switches are designed to handle a total peak current of 6A (minimum).

### Frequency Foldback

The frequency foldback circuit reduces the switching frequency when  $350\text{mV} < \text{FB} < 900\text{mV}$  (typical). This feature lowers the minimum duty cycle that the part can achieve, thus allowing better control of the inductor current during start-up. When the FB voltage is pulled outside of this range, the switching frequency returns to normal.

Note that the peak inductor current at start-up is a function of many variables including load profile, output capacitance, target  $V_{\text{OUT}}$ ,  $V_{\text{IN}}$ , switching frequency, etc. **Test the application's performance at start-up to ensure that the peak inductor current does not exceed the minimum current limit.**

### OPERATION – REGULATION

The following description of the LT3579's operation assumes the FB voltage is close enough to its regulation target so that the part is not in Sample Mode. Use the Block Diagram as a reference when stepping through the following description of the LT3579 operating in regulation. At the start of each oscillator cycle, the SR latch (SR1) is set, which turns on the power switches Q1 and Q2. The collector current through the master switch, Q1, is ~1.3 times the collector current through the slave switch, Q2, when the collectors of the two switches are tied together. Q1's emitter current flows through a current

sense resistor ( $R_S$ ) generating a voltage proportional to the total switch current. This voltage (amplified by A4) is added to a stabilizing ramp and the resulting sum is fed into the positive terminal of the PWM comparator A3. When the voltage on the positive input of A3 exceeds the voltage on the negative input, the SR latch is reset, turning off the master and slave power switches. The voltage on the negative input of A3 ( $V_C$  pin) is set by A1 (or A2), which is simply an amplified difference between the FB pin voltage and the reference voltage (1.215V if the LT3579 is configured as a boost converter, or 9mV if configured as an inverting converter). In this manner, the error amplifier sets the correct peak current level to maintain output regulation.

As long as the part is not in fault (see Operation – FAULT section) and the SS pin exceeds 1.8V, the LT3579 drives its CLKOUT pin at the frequency set by the RT pin or the SYNC pin. The CLKOUT pin can synchronize other compatible switching regulator ICs (including additional LT3579s) with the LT3579. Additionally, the duty cycle of CLKOUT varies linearly with the part's junction temperature and may be used as a temperature monitor. The CLKOUT signal on the LT3579-1 is ~180° out of phase with the internal oscillator and has a fixed duty cycle of ~50%.

### OPERATION – FAULT

The LT3579's  $\overline{\text{FAULT}}$  pin is an active low, bidirectional pin (refer to Block Diagram) that pulls low to indicate a fault. Each of the following events can trigger a fault in the LT3579:

- A. FAULT1 Events:
  1. SW Overcurrent
    - a.  $I_{\text{SW1}} > 3.4\text{A}$  (minimum)
    - b.  $(I_{\text{SW1}} + I_{\text{SW2}}) > 6\text{A}$  (minimum)
  2.  $V_{\text{IN}}$  Voltage  $> 16.2\text{V}$  (minimum)
  3. SW1 Voltage and/or SW2 Voltage  $> 42\text{V}$  (minimum)
  4. Die Temperature  $> 165^\circ\text{C}$
- B. FAULT2 Events:
  1. Pulling the  $\overline{\text{FAULT}}$  pin low externally

## OPERATION

When a fault is detected, in addition to the  $\overline{\text{FAULT}}$  pin being pulled low internally, the LT3579 also disables its CLKOUT pin, turns off its power switches, and the GATE pin becomes high impedance (refer to the State Diagram). The external PMOS, M1, turns off when the gate of M1 is pulled up to its source by the external  $R_{\text{GATE}}$  resistor (see Block Diagram). With the external PMOS turned off, the power path from  $V_{\text{IN}}$  to  $V_{\text{OUT}}$  is cut off, protecting power components downstream.

At the same time, a timeout sequence commences where the SS pin is charged up to 1.8V (the SS pin will continue charging up to ~2.1V and be held there in the case of a FAULT1 event still existing), and then discharged to 50mV. This timeout period relieves the part, the PMOS, and other downstream power components from electrical and thermal stress for a minimum amount of time as set by the voltage ramp rate on the SS pin.

In the absence of faults, the  $\overline{\text{FAULT}}$  pin is pulled high by the external  $R_{\overline{\text{FAULT}}}$  resistor (typically 100k). Figures 4 and 5 show the events that accompany the detection of an output short on the LT3579.

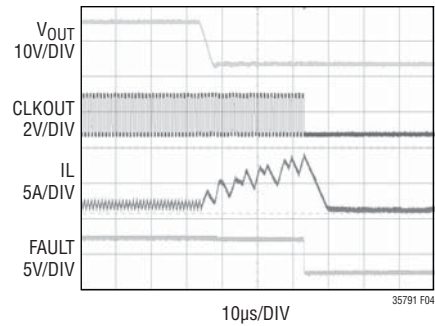

Figure 4. Output Short Circuit Protection of the LT3579

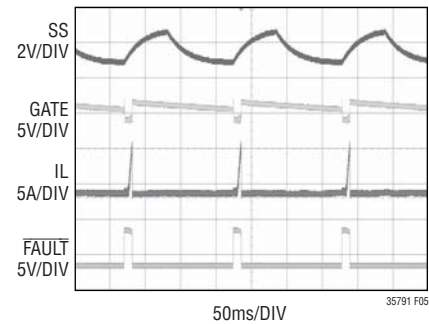
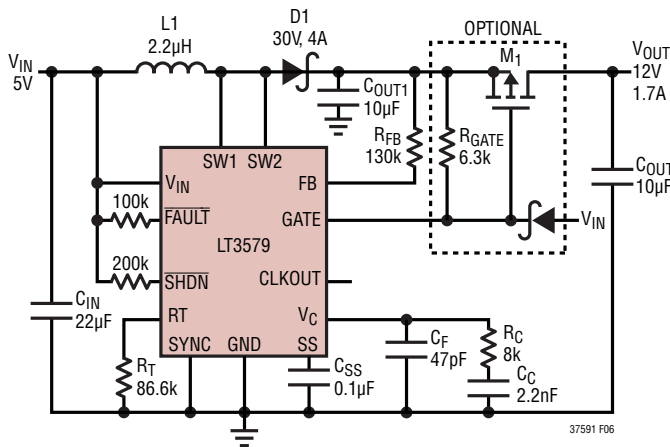

Figure 5. Continuous Output Short Showing  $\overline{\text{FAULT}}$  Timeout Cycle

# APPLICATIONS INFORMATION

## BOOST CONVERTER COMPONENT SELECTION



**Figure 6. Boost Converter – The Component Values Given Are Typical Values for a 1MHz, 5V to 12V Boost**

The LT3579 can be configured as a Boost converter as in Figure 6. This topology allows for positive output voltages that are higher than the input voltage. An external PMOS (optional) driven by the GATE pin of the LT3579 can achieve input or output disconnect during a FAULT event. A single feedback resistor sets the output voltage. For output voltages higher than 40V, see the Charge Pump topology in the Charge Pump Aided Regulators section.

Table 1 is a step-by-step set of equations to calculate component values for the LT3579 when operating as a Boost converter. Input parameters are input and output voltage, and switching frequency ( $V_{IN}$ ,  $V_{OUT}$  and  $f_{OSC}$  respectively). Refer to the Appendix for further information on the design equations presented in Table 1.

### Variable Definitions:

- $V_{IN}$  = Input Voltage
- $V_{OUT}$  = Output Voltage
- DC = Power Switch Duty Cycle
- $f_{OSC}$  = Switching Frequency
- $I_{OUT}$  = Maximum Output Current
- $I_{RIPPLE}$  = Inductor Ripple Current
- $R_{DSON\_PMOS}$  =  $R_{DSON}$  of External PMOS (set to 0 if not using PMOS)

**Table 1. Boost Design Equations**

	PARAMETERS/EQUATIONS
<b>Step 1: Inputs</b>	Pick $V_{IN}$ , $V_{OUT}$ , and $f_{OSC}$ to calculate equations below.
<b>Step 2: DC</b>	$DC \approx \frac{V_{OUT} - V_{IN} + 0.5V}{V_{OUT} + 0.5V - 0.27V}$
<b>Step 3: L1</b>	$L_{TYP} = \frac{(V_{IN} - 0.27V) \cdot DC}{f_{OSC} \cdot 1.8A} \quad (1)$
	$L_{MIN} = \frac{(V_{IN} - 0.27V) \cdot (2 \cdot DC - 1)}{4A \cdot f_{OSC} \cdot (1 - DC)} \quad (2)$
	$L_{MAX} = \frac{(V_{IN} - 0.27V) \cdot DC}{f_{OSC} \cdot 0.5A} \quad (3)$
	<ul style="list-style-type: none"> <li>• Solve equations 1, 2, and 3.</li> <li>• Choose the higher value between <math>L_{TYP}</math> and <math>L_{MIN}</math> for L1. L1 should never exceed <math>L_{MAX}</math>.</li> </ul>
<b>Step 4: <math>I_{RIPPLE}</math></b>	$I_{RIPPLE} = \frac{(V_{IN} - 0.27V) \cdot DC}{f_{OSC} \cdot L1}$
<b>Step 5: <math>I_{OUT}</math></b>	$I_{OUT} = \left( 6A - \frac{I_{RIPPLE}}{2} \right) \cdot (1 - DC)$
<b>Step 6: D1</b>	$V_R > V_{OUT}; I_{AVG} > I_{OUT}$
<b>Step 7: <math>C_{OUT}</math>, <math>C_{OUT1}</math></b>	$C_{OUT} = C_{OUT1} = \frac{I_{OUT} \cdot DC}{f_{OSC} \cdot (0.01 \cdot V_{OUT} - 0.5 \cdot I_{OUT} \cdot R_{DSON\_PMOS})}$
<b>Step 8: <math>C_{IN}</math></b>	$C_{IN} = C_{PWR} + C_{VIN}$ $C_{IN} = \frac{I_{RIPPLE}}{8 \cdot f_{OSC} \cdot 0.005 \cdot V_{IN}} + \frac{6A \cdot DC}{40 \cdot f_{OSC} \cdot 0.005 \cdot V_{IN}}$
<b>Step 9: <math>R_{FB}</math></b>	$R_{FB} = \frac{V_{OUT} - 1.215V}{83.3\mu A}$
<b>Step 10: <math>R_T</math></b>	$R_T = \frac{87.6}{f_{OSC}} - 1; f_{OSC} \text{ in MHz and } R_T \text{ in } k\Omega$
<b>Step 11: PMOS</b>	Only needed for input or output disconnect. See PMOS Selection in the Appendix for information on sizing the PMOS and the biasing resistor, $R_{GATE}$ .

**Note:** The maximum design target for peak switch current is 6A and is used in this table. The final values for  $C_{OUT}$  and  $C_{IN}$  may deviate from the above equations in order to obtain desired load transient performance for a particular application.

## APPLICATIONS INFORMATION

### SEPIC CONVERTER COMPONENT SELECTION – COUPLED OR UN-COUPLED INDUCTORS

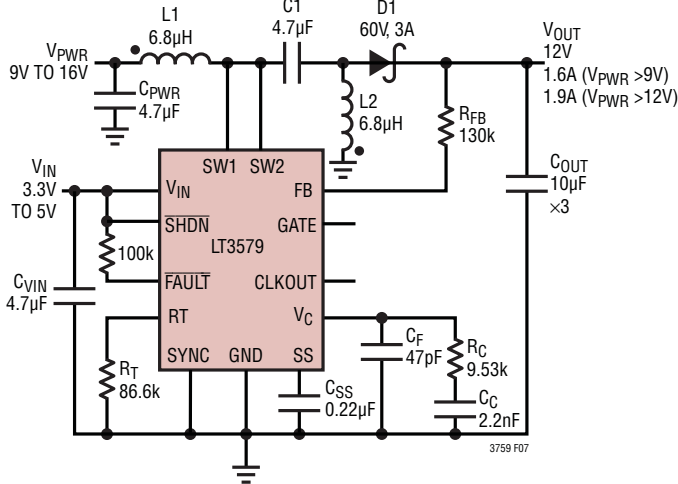

**Figure 7. SEPIC Converter – The Component Values Given Are Typical Values for a 1MHz, 9V–16V to 12V SEPIC Topology Using Coupled Inductors**

The LT3579 can also be configured as a SEPIC as in Figure 7. This topology allows for positive output voltages that are lower, equal, or higher than the input voltage. Output disconnect is inherently built into the SEPIC topology, meaning no DC path exists between the input and output due to capacitor C1. This implies that a PMOS controlled by the GATE pin is not required in the power path.

Table 2 is a step-by-step set of equations to calculate component values for the LT3579 when operating as a SEPIC converter using coupled inductors. Input parameters are input and output voltage, and switching frequency ( $V_{IN}$ ,  $V_{OUT}$  and  $f_{OSC}$  respectively). Refer to the Appendix for further information on the design equations presented in Table 2.

#### Variable Definitions:

- $V_{IN}$  = Input Voltage
- $V_{OUT}$  = Output Voltage
- DC = Power Switch Duty Cycle
- $f_{OSC}$  = Switching Frequency
- $I_{OUT}$  = Maximum Output Current
- $I_{RIPPLE}$  = Inductor Ripple Current

**Table 2. SEPIC Design Equations**

	PARAMETERS/EQUATIONS
<b>Step 1: Inputs</b>	Pick $V_{IN}$ , $V_{OUT}$ , and $f_{OSC}$ to calculate equations below.
<b>Step 2: DC</b>	$DC \cong \frac{V_{OUT} + 0.5V}{V_{IN} + V_{OUT} + 0.5V - 0.27V}$
<b>Step 3: L</b>	$L_{TYP} = \frac{(V_{IN} - 0.27V) \cdot DC}{f_{OSC} \cdot 1.8A} \quad (1)$
	$L_{MIN} = \frac{(V_{IN} - 0.27V) \cdot (2 \cdot DC - 1)}{4A \cdot f_{OSC} \cdot (1 - DC)} \quad (2)$
	$L_{MAX} = \frac{(V_{IN} - 0.27V) \cdot DC}{f_{OSC} \cdot 0.5A} \quad (3)$
	<ul style="list-style-type: none"> <li>• Solve equations 1, 2, and 3.</li> <li>• Choose the higher value between <math>L_{TYP}</math> and <math>L_{MIN}</math> for L. L should never exceed <math>L_{MAX}</math>.</li> <li>• <math>L = L1 = L2</math> for coupled inductors.</li> <li>• <math>L = L1 \parallel L2</math> for un-coupled inductors.</li> </ul>
<b>Step 4: <math>I_{RIPPLE}</math></b>	$I_{RIPPLE} = \frac{(V_{IN} - 0.27V) \cdot DC}{f_{OSC} \cdot L}$
<b>Step 5: <math>I_{OUT}</math></b>	$I_{OUT} = \left( 6A - \frac{I_{RIPPLE}}{2} \right) \cdot (1 - DC)$
<b>Step 6: D1</b>	$V_R > V_{IN} + V_{OUT}; I_{AVG} > I_{OUT}$
<b>Step 7: C1</b>	4.7µF (typical); $V_{RATING} > V_{IN}$
<b>Step 8: <math>C_{OUT}</math></b>	$C_{OUT} = \frac{I_{OUT} \cdot DC}{f_{OSC} \cdot 0.005 \cdot V_{OUT}}$
<b>Step 9: <math>C_{PWR}</math></b>	$C_{PWR} = \frac{I_{RIPPLE}}{8 \cdot f_{OSC} \cdot 0.005 \cdot V_{IN}}$
<b>Step 10: <math>C_{VIN}</math></b>	$C_{VIN} = \frac{6A \cdot DC}{40 \cdot f_{OSC} \cdot 0.005 \cdot V_{IN}}$
<b>Step 11: <math>R_{FB}</math></b>	$R_{FB} = \frac{V_{OUT} - 1.215V}{83.3\mu A}$
<b>Step 12: <math>R_T</math></b>	$R_T = \frac{87.6}{f_{OSC}} - 1; f_{OSC} \text{ in MHz and } R_T \text{ in k}\Omega$

**Note:** The maximum design target for peak switch current is 6A and is used in this table. The final values for  $C_{OUT}$ ,  $C_{PWR}$ , and  $C_{VIN}$  may deviate from the above equations in order to obtain desired load transient performance for a particular application.



## APPLICATIONS INFORMATION

### DUAL INDUCTOR INVERTING CONVERTER COMPONENT SELECTION – COUPLED OR UN-COUPLED INDUCTORS

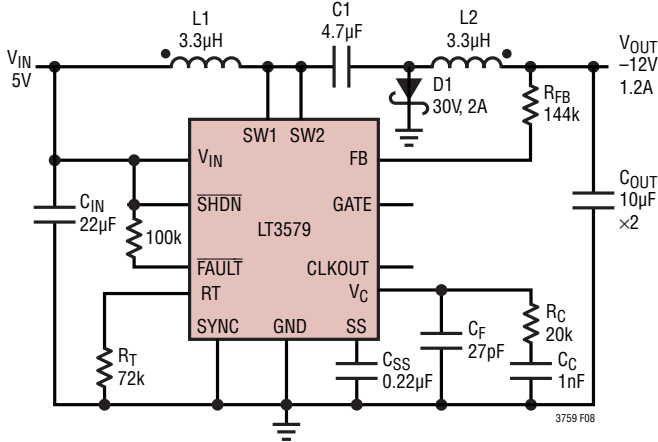

**Figure 8. Dual Inductor Inverting Converter – The Component Values Given Are Typical Values for a 1.2MHz, 5V to -12V Inverting Topology Using Coupled Inductors**

Due to its unique FB pin, the LT3579 can work in a Dual Inductor Inverting configuration as in Figure 8. Changing the connections of L2 and the Schottky diode in the SEPIC topology, results in generating negative output voltages. This solution results in very low output voltage ripple due to inductor L2 in series with the output. Output disconnect is inherently built into this topology due to the capacitor C1.

Table 3 is a step-by-step set of equations to calculate component values for the LT3579 when operating as a Dual Inductor Inverting converter using coupled inductors. Input parameters are input and output voltage, and switching frequency ( $V_{IN}$ ,  $V_{OUT}$  and  $f_{OSC}$  respectively). Refer to the Appendix for further information on the design equations presented in Table 3.

#### Variable Definitions:

- $V_{IN}$  = Input Voltage
- $V_{OUT}$  = Output Voltage
- DC = Power Switch Duty Cycle
- $f_{OSC}$  = Switching Frequency
- $I_{OUT}$  = Maximum Output Current
- $I_{RIPPLE}$  = Inductor Ripple Current

**Table 3. Dual Inductor Inverting Design Equations**

	PARAMETERS/EQUATIONS
<b>Step 1: Inputs</b>	Pick $V_{IN}$ , $V_{OUT}$ , and $f_{OSC}$ to calculate equations below.
<b>Step 2: DC</b>	$DC = \frac{ V_{OUT}  + 0.5V}{V_{IN} +  V_{OUT}  + 0.5V - 0.27V}$
<b>Step 3: L</b>	$L_{TYP} = \frac{(V_{IN} - 0.27V) \cdot DC}{f_{OSC} \cdot 1.8A} \quad (1)$
	$L_{MIN} = \frac{(V_{IN} - 0.27V) \cdot (2 \cdot DC - 1)}{4A \cdot f_{OSC} \cdot (1 - DC)} \quad (2)$
	$L_{MAX} = \frac{(V_{IN} - 0.27V) \cdot DC}{f_{OSC} \cdot 0.5A} \quad (3)$
	<ul style="list-style-type: none"> <li>• Solve equations 1, 2, and 3.</li> <li>• Choose the higher value between <math>L_{TYP}</math> and <math>L_{MIN}</math> for L. L should never exceed <math>L_{MAX}</math>.</li> <li>• <math>L = L1 = L2</math> for coupled inductors.</li> <li>• <math>L = L1 \parallel L2</math> for un-coupled inductors.</li> </ul>
<b>Step 4: <math>I_{RIPPLE}</math></b>	$I_{RIPPLE} = \frac{(V_{IN} - 0.27V) \cdot DC}{f_{OSC} \cdot L}$
<b>Step 5: <math>I_{OUT}</math></b>	$I_{OUT} = \left(6A - \frac{I_{RIPPLE}}{2}\right) \cdot (1 - DC)$
<b>Step 6: D1</b>	$V_R > V_{IN} +  V_{OUT} ; I_{AVG} > I_{OUT}$
<b>Step 7: C1</b>	$4.7\mu F \text{ (typical)}; V_{RATING} > V_{IN} +  V_{OUT} $
<b>Step 8: <math>C_{OUT}</math></b>	$C_{OUT} = \frac{I_{RIPPLE}}{8 \cdot f_{OSC} \cdot 0.005 \cdot  V_{OUT} }$
<b>Step 9: <math>C_{IN}</math></b>	$C_{IN} = C_{PWR} + C_{VIN}$ $C_{IN} = \frac{I_{RIPPLE}}{8 \cdot f_{OSC} \cdot 0.005 \cdot V_{IN}} + \frac{6A \cdot DC}{40 \cdot f_{OSC} \cdot 0.005 \cdot V_{IN}}$
<b>Step 10: <math>R_{FB}</math></b>	$R_{FB} = \frac{ V_{OUT}  + 9mV}{83.3\mu A}$
<b>Step 11: <math>R_T</math></b>	$R_T = \frac{87.6}{f_{OSC}} - 1; f_{OSC} \text{ in MHz and } R_T \text{ in } k\Omega$

**Note:** The maximum design target for peak switch current is 6A and is used in this table. The final values for  $C_{OUT}$  and  $C_{IN}$  may deviate from the above equations in order to obtain desired load transient performance for a particular application.

## APPLICATIONS INFORMATION

### LAYOUT GUIDELINES FOR BOOST, SEPIC, AND DUAL INDUCTOR INVERTING TOPOLOGIES

#### General Layout Guidelines

- To optimize thermal performance, solder the exposed ground pad of the LT3579 to the ground plane with multiple vias around the pad connecting to additional ground planes.
- A ground plane should be used under the switcher circuitry to prevent interplane coupling and overall noise.
- High speed switching path (see specific topology below for more information) must be kept as short as possible.
- The  $V_C$ , FB, and RT components should be placed as close to the LT3579 as possible, while being as far away as practically possible from the switch node. The ground for these components should be separated from the switch current path.
- Place the bypass capacitor for the  $V_{IN}$  pin ( $C_{VIN}$ ) as close as possible to the LT3579.

- Place the bypass capacitor for the inductor ( $C_{PWR}$ ) as close as possible to the inductor.
- Bypass capacitors,  $C_{PWR}$  and  $C_{VIN}$ , may be combined into a single bypass capacitor,  $C_{IN}$ , if the input side of the inductor can be close to the  $V_{IN}$  pin of the LT3579.
- The load should connect directly to the positive and negative terminals of the output capacitor for best load regulation.

#### Boost Topology Specific Layout Guidelines

- Keep length of loop (high speed switching path) governing switch, diode D1, output capacitor  $C_{OUT}$ , and ground return as short as possible to minimize parasitic inductive spikes at the switch node during switching.

#### SEPIC Topology Specific Layout Guidelines

- Keep length of loop (high speed switching path) governing switch, flying capacitor C1, diode D1, output capacitor  $C_{OUT}$ , and ground return as short as possible to minimize parasitic inductive spikes at the switch node during switching.

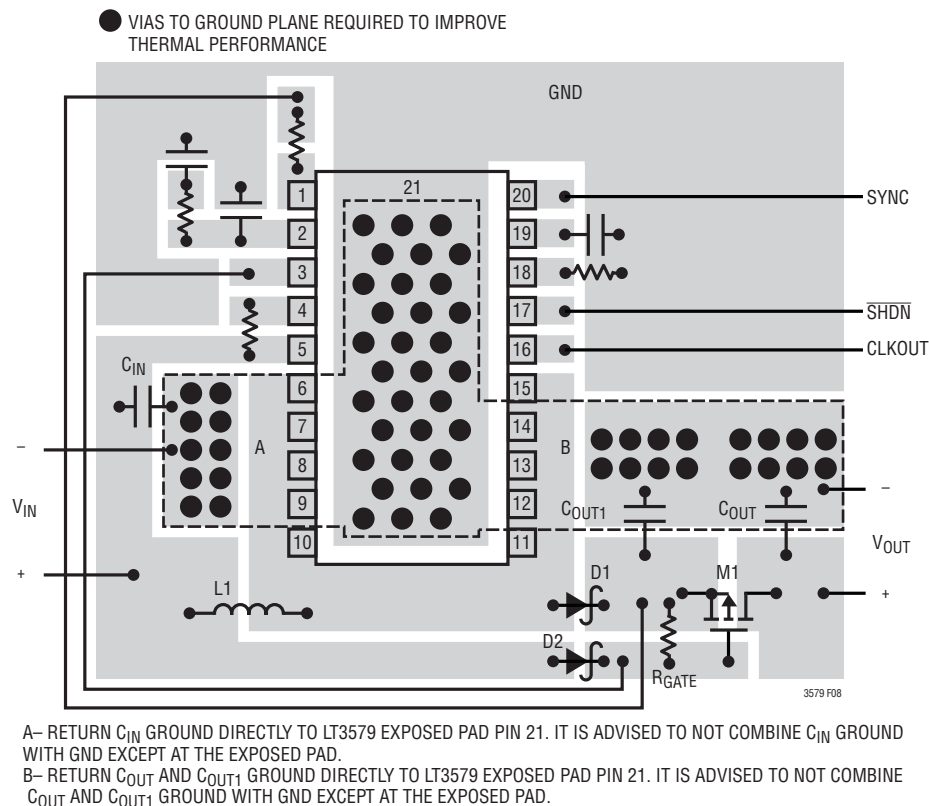

Figure 9. Suggested Component Placement for Boost Topology in FE20 Package



## APPLICATIONS INFORMATION

### Inverting Topology Specific Layout Guidelines

- Keep ground return path from the cathode of D1 (to chip) separated from output capacitor  $C_{OUT}$ 's ground return path (to chip) in order to minimize switching noise coupling into the output. Notice the separate ground return for D1's cathode in Figure 11.
- Keep length of loop (high speed switching path) governing switch, flying capacitor C1, diode D1, and ground return as short as possible to minimize parasitic inductive spikes at the switch node during switching.

### THERMAL CONSIDERATIONS

For the LT3579 to deliver its full output power, it is imperative that a good thermal path be provided to dissipate

the heat generated within the package. This can be accomplished by taking advantage of the thermal pad on the underside of the IC. It is recommended that multiple vias in the printed circuit board be used to conduct heat away from the IC and into a copper plane with as much area as possible.

### Power & Thermal Calculations

Power dissipation in the LT3579 chip comes from four primary sources: switch  $I^2R$  loss, NPN base drive loss (AC), NPN base drive loss (DC), and additional  $V_{IN}$  pin current. These formulas assume continuous mode operation, so they should not be used for calculating thermal losses or efficiency in discontinuous mode or at light load currents.

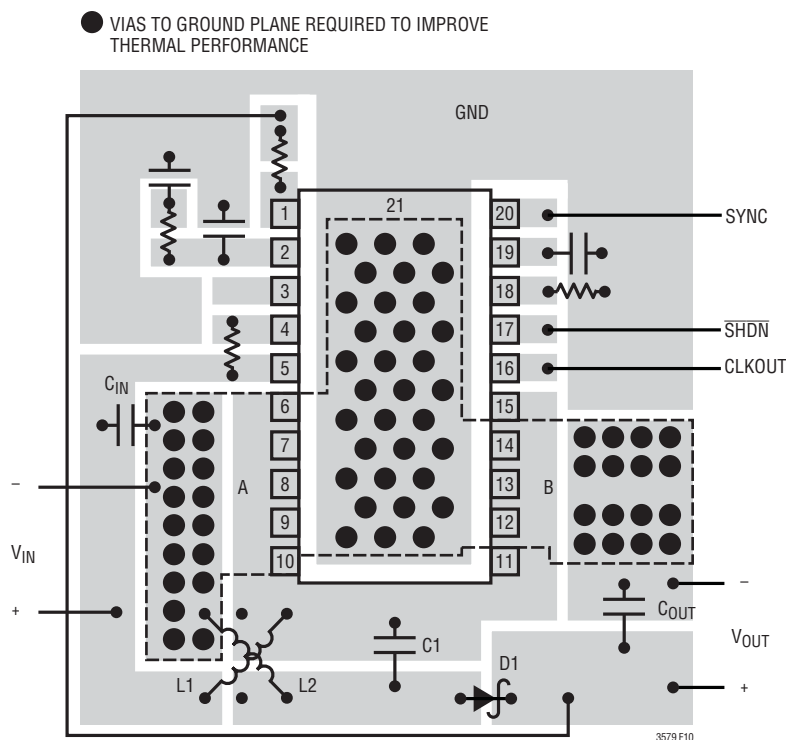

A- RETURN  $C_{IN}$  AND L2 GROUND DIRECTLY TO LT3579 EXPOSED PAD PIN 21. IT IS ADVISED TO NOT COMBINE  $C_{IN}$  AND L2 GROUND WITH GND EXCEPT AT THE EXPOSED PAD.  
 B- RETURN  $C_{OUT}$  GROUND DIRECTLY TO LT3579 EXPOSED PAD PIN 21. IT IS ADVISED TO NOT COMBINE  $C_{OUT}$  GROUND WITH GND EXCEPT AT THE EXPOSED PAD.  
 L1, L2 - MOST COUPLED INDUCTOR MANUFACTURERS USE CROSS PINOUT FOR IMPROVED PERFORMANCE.

Figure 10. Suggested Component Placement for SEPIC Topology in FE20 Package

APPLICATIONS INFORMATION

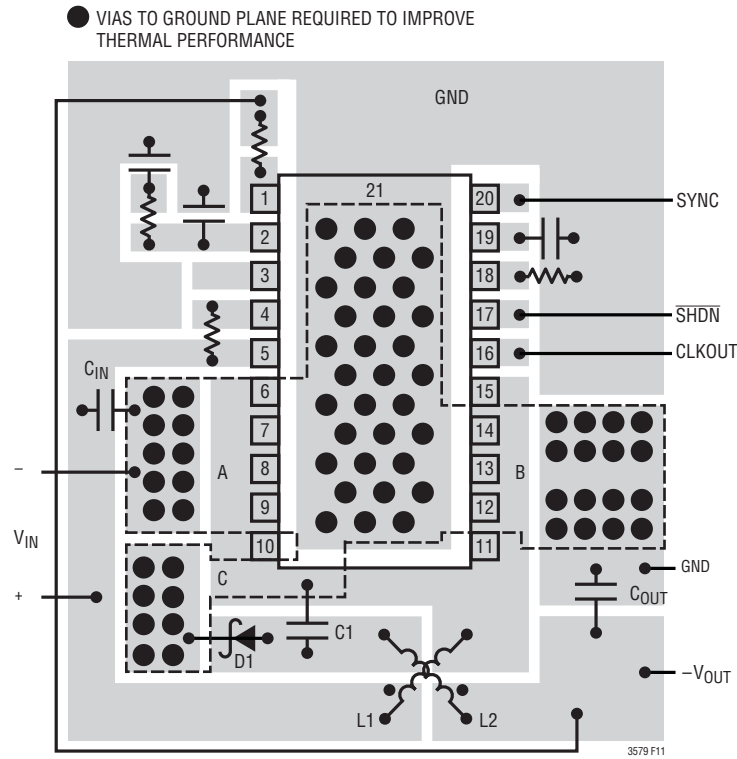

A- RETURN  $C_{IN}$  GROUND DIRECTLY TO LT3579 EXPOSED PAD PIN 21. IT IS ADVISED TO NOT COMBINE  $C_{IN}$  GROUND WITH GND EXCEPT AT THE EXPOSED PAD.  
 B- RETURN  $C_{OUT}$  GROUND DIRECTLY TO LT3579 EXPOSED PAD PIN 21. IT IS ADVISED TO NOT COMBINE  $C_{OUT}$  GROUND WITH GND EXCEPT AT THE EXPOSED PAD.  
 C- RETURN D1 GROUND DIRECTLY TO LT3579 EXPOSED PAD PIN 21. IT IS ADVISED TO NOT COMBINE D1 GROUND WITH GND EXCEPT AT THE EXPOSED PAD.  
 L1, L2 - MOST COUPLED INDUCTOR MANUFACTURERS USE CROSS PINOUT FOR IMPROVED PERFORMANCE.

**Figure 11. Suggested Component Placement for Inverting Topology in FE20 Package.  
 Note Separate Ground Path for D1's Cathode**

## APPLICATIONS INFORMATION

The following example calculates the power dissipation in the LT3579 for a particular boost application:

$$(V_{IN} = 5V, V_{OUT} = 12V, I_{OUT} = 1.5A, f_{OSC} = 1MHz, V_D = 0.5V, V_{CESAT} = 0.185V).$$

To calculate die junction temperature, use the appropriate thermal resistance number and add in worst-case ambient temperature:

$$T_J = T_A + \theta_{JA} \cdot P_{TOTAL}$$

where  $T_J$ =Die Junction Temperature,  $T_A$ =Ambient Temperature,  $P_{TOTAL}$  is the final result from the calculations shown in Table 4, and  $\theta_{JA}$  is the thermal resistance from the silicon junction to the ambient air.

**Table 4. Boost Power Calculations Example with  $V_{IN} = 5V$ ,  $V_{OUT} = 12V$ ,  $I_{OUT} = 1.5A$ ,  $f_{OSC} = 1MHz$ ,  $V_D = 0.5V$ ,  $V_{CESAT} = 0.185V$**

DEFINITION OF VARIABLES	EQUATIONS	DESIGN EXAMPLE	VALUE
DC = Switch Duty Cycle	$DC = \frac{V_{OUT} - V_{IN} + V_D}{V_{OUT} + V_D - V_{CESAT}}$	$DC = \frac{12V - 5V + 0.5V}{12V + 0.5V - .185V}$	DC = 60.9%
$I_{IN}$ = Average Input Current $\eta$ = Power Conversion Efficiency (typically 90% at high currents)	$I_{IN} = \frac{V_{OUT} \cdot I_{OUT}}{V_{IN} \cdot \eta}$	$I_{IN} = \frac{12V \cdot 1.5A}{5V \cdot 0.9}$	$I_{IN} = 4A$
$P_{SW}$ = Switch $I^2R$ Loss $R_{SW}$ = Switch Resistance (typically 45m $\Omega$ combined SW1 and SW2)	$P_{SW} = DC \cdot I_{IN}^2 \cdot R_{SW}$	$P_{SW} = 0.609 \cdot (4A)^2 \cdot 45m\Omega$	$P_{SW} = 438mW$
$P_{BAC}$ = Base Drive Loss (AC)	$P_{BAC} = 13ns \cdot I_{IN} \cdot V_{OUT} \cdot f_{OSC}$	$P_{BAC} = 13ns \cdot 4A \cdot 12V \cdot 1MHz$	$P_{BAC} = 624mW$
$P_{BDC}$ = Base Drive Loss (DC)	$P_{BDC} = \frac{V_{IN} \cdot I_{IN} \cdot DC}{40}$	$P_{BDC} = \frac{5V \cdot 4A \cdot 0.609}{40}$	$P_{BDC} = 305mW$
$P_{INP}$ = Input Power Loss	$P_{INP} = 14mA \cdot V_{IN}$	$P_{INP} = 14mA \cdot 5V$	$P_{INP} = 70mW$
			$P_{TOTAL} = 1.437W$

## APPLICATIONS INFORMATION

The published ([http://www.linear.com/designtools/packaging/Linear\\_Technology\\_Thermal\\_Resistance\\_Table.pdf](http://www.linear.com/designtools/packaging/Linear_Technology_Thermal_Resistance_Table.pdf))  $\theta_{JA}$  value is 38°C/W for the TSSOP Exposed Pad package and 34°C/W for the 4mm × 5mm QFN package. In practice, lower  $\theta_{JA}$  values are realizable if board layout is performed with appropriate grounding (accounting for heat sinking properties of the board) and other considerations listed in the Layout Guidelines section. For instance, a  $\theta_{JA}$  value of ~22°C/W was consistently achieved for both TSSOP and QFN packages of the LT3579 (at  $V_{IN} = 5V$ ,  $V_{OUT} = 12V$ ,  $I_{OUT} = 1.7A$ ,  $f_{OSC} = 1MHz$ ) when board layout was optimized as per the suggestions in the Layout Guidelines section.

### Junction Temperature Measurement

The duty cycle of the CLKOUT signal on the LT3579 is linearly proportional to die junction temperature,  $T_J$  (the CLKOUT duty cycle on the LT3579-1 is fixed at ~50%). To get an accurate reading, measure the duty cycle of the CLKOUT signal and use the following equation to approximate the junction temperature:

$$T_J = \frac{DC_{CLKOUT} - 35\%}{0.3\%}$$

where  $DC_{CLKOUT}$  is the CLKOUT duty cycle in % and  $T_J$  is the die junction temperature in °C. Although the absolute die temperature can deviate from the above equation by ±15°C, the relationship between change in CLKOUT duty cycle and change in die temperature is well defined. A 3% increase in CLKOUT duty cycle corresponds to ~10°C increase in die temperature:

Note that the CLKOUT pin is only meant to drive capacitive loads up to 50pF.

### Thermal Lockout

A fault condition occurs when the die temperature exceeds ~165°C (see Operation – FAULT Section), and the part goes into thermal lockout. The fault condition ceases when the die temperature drops by ~5°C (nominal).

### SWITCHING FREQUENCY

There are several considerations in selecting the operating frequency of the converter. The first is staying clear of sensitive frequency bands, which cannot tolerate any spectral noise. For example, in products incorporating RF communications, the 455kHz IF frequency is sensitive to any noise, therefore switching above 600kHz is desired. Some communications have sensitivity to 1.1MHz and in that case a 1.5MHz switching converter frequency may be employed. The second consideration is the physical size of the converter. As the operating frequency goes up, the inductor and filter capacitors go down in value and size. The tradeoff is efficiency, since the switching losses due to NPN base charge (see Thermal Considerations), Schottky diode charge, and other capacitive loss terms increase proportionally with frequency.

### Oscillator Timing Resistor ( $R_T$ )

The operating frequency of the LT3579 can be set by the internal free-running oscillator. When the SYNC pin is driven low (< 0.4V), the frequency of operation is set by a resistor from the  $R_T$  pin to ground. An internally trimmed timing capacitor resides inside the IC. The oscillator frequency is calculated using the following formula:

$$f_{OSC} = \frac{87.6}{R_T + 1}$$

where  $f_{OSC}$  is in MHz and  $R_T$  is in kΩ. Conversely,  $R_T$  (in kΩ) can be calculated from the desired frequency (in MHz) using:

$$R_T = \frac{87.6}{f_{OSC}} - 1$$

## APPLICATIONS INFORMATION

### Clock Synchronization

An external source can set the operating frequency of the LT3579 by providing a digital clock signal into the SYNC pin ( $R_T$  resistor still required). The LT3579 will operate at the SYNC clock frequency. The LT3579 will revert to its internal free-running oscillator clock when the SYNC pin is driven below 0.4V for a few free-running clock periods.

Driving SYNC high for an extended period of time effectively stops the operating clock and prevents latch SR1 from becoming set (see Block Diagram). As a result, the switching operation of the LT3579 will stop and the CLKOUT pin will be held at ground.

The duty cycle of the SYNC signal must be between 20% and 80% for proper operation. Also, the frequency of the SYNC signal must meet the following two criteria:

1. SYNC may not toggle outside the frequency range of 200kHz-2.5MHz unless it is stopped below 0.4V to enable the free-running oscillator.
2. The SYNC frequency can always be higher than the free-running oscillator frequency (as set by the  $R_T$  resistor),  $f_{OSC}$ , but should not be less than 25% below  $f_{OSC}$ .

### CLOCK SYNCHRONIZATION OF ADDITIONAL REGULATORS

The CLKOUT pin of the LT3579 can synchronize additional switching regulators and/or additional LT3579s as shown in Figure 12.

The frequency of the master LT3579 is set by the external  $R_T$  resistor. The SYNC pin of the slave LT3579 is driven by the CLKOUT pin of the master LT3579. Note that the RT pin of the slave LT3579 must have a resistor tied to ground. It takes a few clock cycles for the CLKOUT signal to begin oscillating, and it's preferable for all LT3579s to have the same internal free-running frequency. Therefore, in general, use the same value  $R_T$  resistor for all of the synchronized LT3579s.

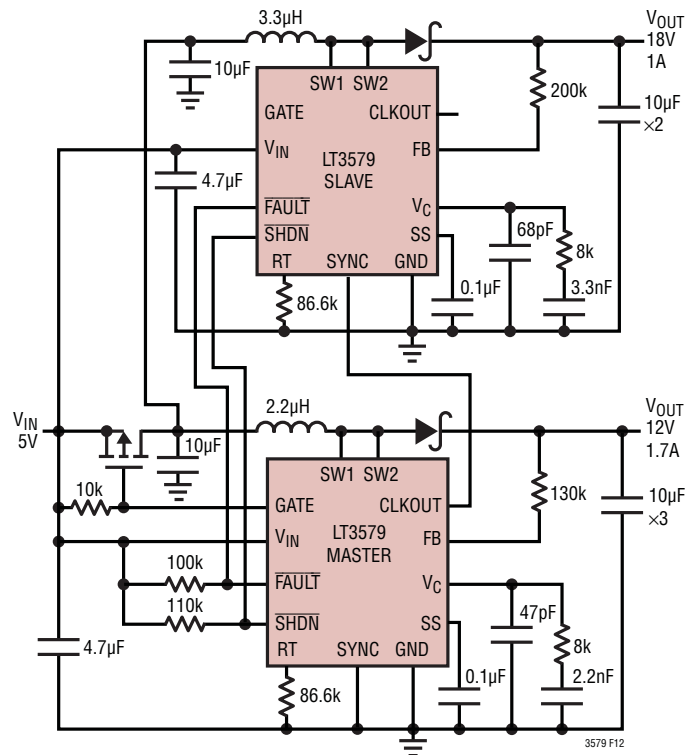

Figure 12. Synchronize Multiple LT3579s. The External PMOS Disconnects the Input from Both Power Paths During FAULT Events

Also, the  $\overline{\text{FAULT}}$  pins can be tied together so that a fault condition from one LT3579 causes all of the LT3579s to enter fault, until the fault condition disappears.

### 2-Phase Converters using LT3579-1

The CLKOUT pin on the LT3579-1 is  $\sim 180^\circ$  out of phase with the internal oscillator, which allows two LT3579-1s to operate in parallel for a high current, high power output. The advantage of multiphase converters is that the ripple current flowing into the output node is divided by the number of phases or ICs used to generate the output voltage. The  $V_{IN}$ ,  $\overline{\text{SHDN}}$ ,  $\overline{\text{FAULT}}$ , FB, and  $V_C$  pins of all the LT3579-1s should be connected together. Figure 13 shows a typical application of a 2-phase 12V to 24V boost with output disconnect.

## APPLICATIONS INFORMATION

Use the following equations to calculate the FB resistor for 2-phase converters:

$$R_{FB} = \left( \frac{V_{OUT} - 1.215V}{2 \cdot 83.3\mu A} \right); \text{ Boost or SEPIC Multiphase Converter}$$

$$R_{FB} = \left( \frac{|V_{OUT}| + 9mV}{2 \cdot 83.3\mu A} \right); \text{ Inverting Multiphase Converter}$$

Note that the CLKOUT pin on the LT3579-1 runs at a fixed duty cycle of ~50%. If monitoring the die temperature is desired, the slave IC can be a LT3579.

It is possible to use the LT3579-1 in a multiphase converter of more than 2 phases. Consult the LTC Applications Engineering Department for more information.

### CHARGE PUMP AIDED REGULATORS

Designing charge pumps with the LT3579 can offer efficient solutions with fewer components than traditional circuits because of the master/slave switch configuration on the IC. The current in the master switch (SW1) is sensed by the current comparator (A4 in Block Diagram), but the current in the slave switch (SW2) is not. Note that the slave switch, SW2, operates in phase with SW1. This method of operation by the master/slave switches can offer the following benefits to charge pump designs:

- The slave switch, by not performing a current sense operation like the master switch, can sustain fairly large current spikes when the flying capacitors charge up. Since this current spike flows through SW2, it does not affect the operation of the current comparator (A4 in Block Diagram).
- The master switch, immune from the capacitor current spike, can sense the inductor current more accurately.
- Since the slave switch can sustain large current spikes, the diodes that feed current into the flying capacitors do not need current limiting resistors, leading to efficiency and thermal improvements.

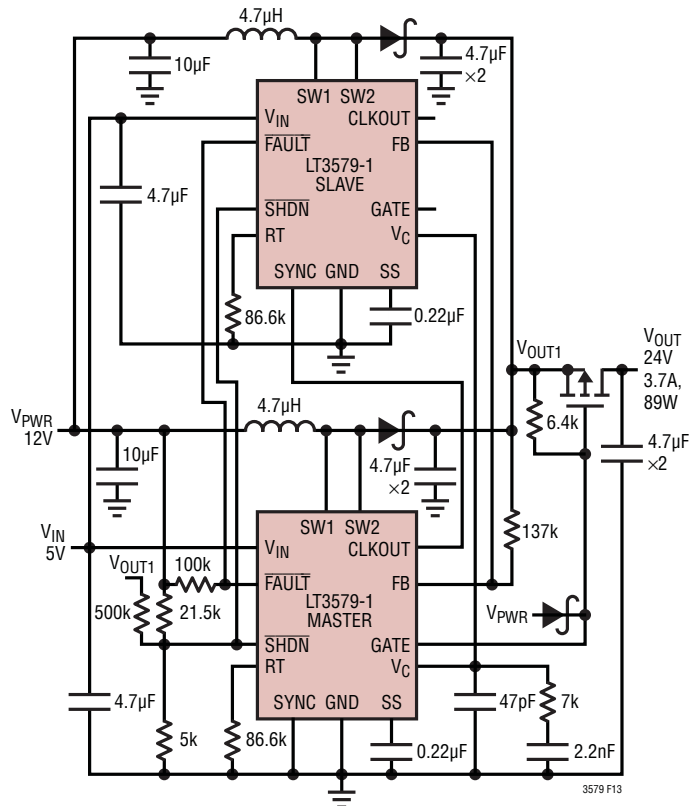

Figure 13. 2-Phase Converters Using LT3579-1

### High V<sub>OUT</sub> Charge Pump Topology

The LT3579 can be used in a charge-pump topology (refer to Figure 16), multiplying the output of an inductive boost converter. The master switch (SW1) can be used to drive the inductive boost converter, while the slave switch (SW2) can be used to drive one or more charge pump stages. This topology is useful for high voltage applications including VFD Bias Supplies.

### Single Inductor Inverting Topology

If there is a need to use just 1 inductor to generate a negative output voltage whose magnitude is greater than V<sub>IN</sub>, the Single Inductor Inverting topology (shown in Figure 15) can be used. Since the master and slave switches are isolated by an external Schottky diode, the current spike through C1 will flow through the slave switch, thereby preventing the current comparator (A4 in Block Diagram) from falsely tripping. Output disconnect is inherently built into the single inductor topology.

## APPLICATIONS INFORMATION

### HOT PLUG

The high inrush current associated with hot-plugging  $V_{IN}$  can be largely rejected with the use of an external PMOS. A simple hot-plug controller can be designed by connecting an external PMOS in series with  $V_{IN}$ , with the gate of the PMOS being driven by the GATE pin of the LT3579. Since the GATE pin pull-down current is linearly proportional to the SS voltage, and the SS charge up time is relatively slow, the GATE pin pull-down current will increase gradually, thereby turning on the external PMOS slowly. Controlled in this manner, the PMOS acts as an input current limiter when  $V_{IN}$  hot-plugs or ramps up sharply.

Likewise, when the PMOS is connected in series with the output, inrush currents into the output capacitor can be limited during a hot-plug event. To illustrate this, the circuit in Figure 6 was re-configured by adding a large 1500 $\mu$ F capacitor to the output. An 18 $\Omega$  resistive load was used and a 2.2 $\mu$ F capacitor was placed on SS. Figure 14 shows the result of hot-plugging this re-configured circuit. The inductor current is well behaved and  $V_{OUT}$  comes up once  $V_{IN}$  settles out.

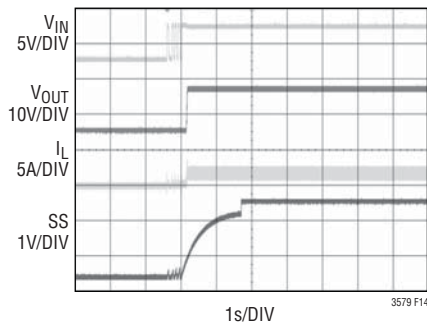

Figure 14.  $V_{IN}$  Hot-Plug Control. Inrush Current is Well Controlled

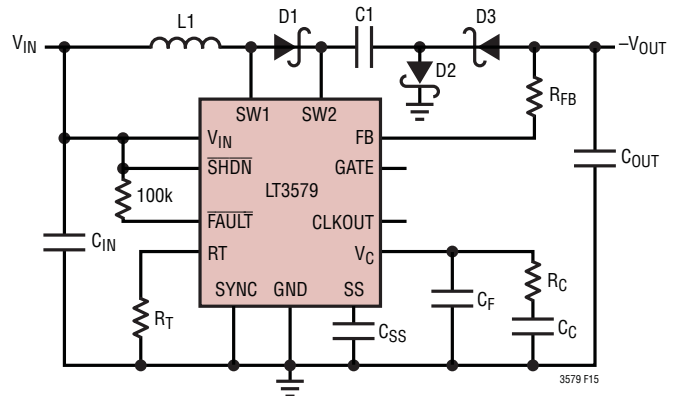

Figure 15. Single Inductor Inverting Topology

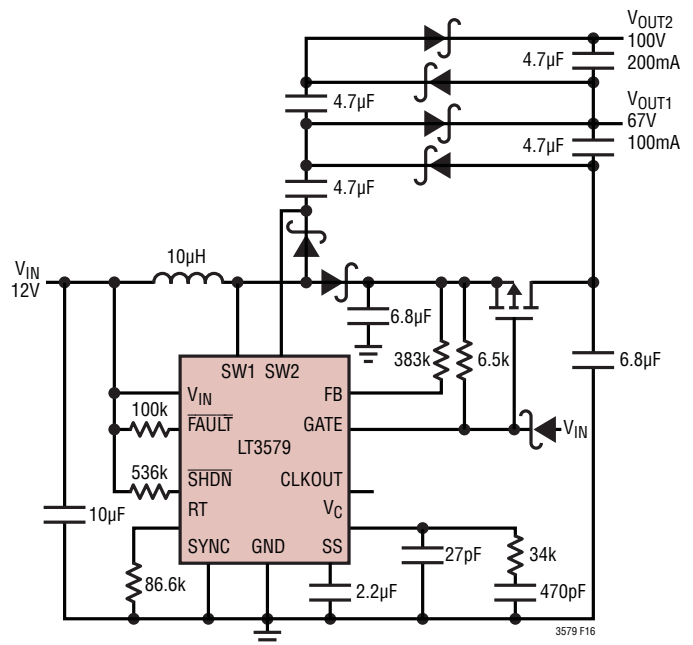

Figure 16. High  $V_{OUT}$  Charge Pump Topology



## APPENDIX

### SETTING THE OUTPUT VOLTAGE

The output voltage is set by connecting a resistor ( $R_{FB}$ ) from  $V_{OUT}$  to the FB pin.  $R_{FB}$  is determined from the following equation:

$$R_{FB} = \frac{|V_{OUT} - V_{FB}|}{83.3\mu A}$$

where  $V_{FB}$  is 1.215V (typical) for non-inverting topologies (i.e. boost and SEPIC regulators) and 9mV (typical) for inverting topologies (see Electrical Characteristics).

### POWER SWITCH DUTY CYCLE

In order to maintain loop stability and deliver adequate current to the load, the power NPNs (Q1 and Q2 in the Block Diagram) cannot remain “on” for 100% of each clock cycle. The maximum allowable duty cycle is given by:

$$DC_{MAX} = \frac{(T_P - \text{MinOffTime})}{T_P} \cdot 100\%$$

where  $T_P$  is the clock period and MinOffTime (found in the Electrical Characteristics) is typically 45nS.

Conversely, the power NPNs (Q1 and Q2 in the Block Diagram) cannot remain “off” for 100% of each clock cycle, and will turn on for a minimum time (MinOnTime) when in regulation. This MinOnTime governs the minimum allowable duty cycle given by:

$$DC_{MIN} = \frac{(\text{MinOnTime})}{T_P} \cdot 100\%$$

where  $T_P$  is the clock period and MinOnTime (found in the Electrical Characteristics) is typically 55nS.

The application should be designed such that the operating duty cycle is between  $DC_{MIN}$  and  $DC_{MAX}$ .

Duty cycle equations for several common topologies are given below where  $V_D$  is the diode forward voltage drop and  $V_{CESAT}$  is typically 250mV at 5.5A for a combined SW1 and SW2 current.

For the boost topology (see Figure 6):

$$DC_{BOOST} \approx \frac{V_{OUT} - V_{IN} + V_D}{V_{OUT} + V_D - V_{CESAT}}$$

For the SEPIC or Dual Inductor Inverting topology (see Figures 7 and 8):

$$DC_{SEPIC\_ \& \_ INVERT} \approx \frac{V_D + |V_{OUT}|}{V_{IN} + |V_D| + V_{OUT} - V_{CESAT}}$$

For the Single Inductor Inverting topology (see Figure 14):

$$DC_{SI\_ INVERT} \approx \frac{|V_{OUT}| - V_{IN} + V_{CESAT} + 3 \cdot V_D}{|V_{OUT}| + 3 \cdot V_D}$$

The LT3579 can be used in configurations where the duty cycle is higher than  $DC_{MAX}$ , but it must be operated in the discontinuous conduction mode so that the effective duty cycle is reduced.

### INDUCTOR SELECTION

The high frequency operation of the LT3579 allows for the use of small surface mount inductors. For high efficiency, choose inductors with high frequency core material, such as ferrite, to reduce core losses. Also to improve efficiency, choose inductors with more volume for a given inductance. The inductor should have low DCR (copper-wire resistance) to reduce  $I^2R$  losses, and must be able to handle the peak inductor current without saturating. Note that in some applications, the current handling requirements of the inductor can be lower, such as in the SEPIC topology where each inductor only carries one half of the total switch current. Multilayer chokes or chip inductors usually do not have enough core volume to support peak inductor currents in the 4A to 7A range. To minimize radiated noise, use a toroidal or shielded inductor. See Table 5 for a list of inductor manufacturers.



## APPENDIX

**Table 5. Inductor Manufacturers**

Vishay	IHLP-2020BZ-01 and IHLP-2525CZ-01 Series	www.vishay.com
Coilcraft	XLP, MLC and MSS Series	www.coilcraft.com
Cooper Bussmann	DRQ125 and DRQ127 Series	www.cooperbussmann.com
Sumida	CDRH series	www.sumida.com
TDK	RLF and SLF series	www.tdk.com
Würth	WE-PD, WE-PDF, WE-HC and WE-DD Series	www.we-online.com

### Minimum Inductance

Although there can be a tradeoff with efficiency, it is often desirable to minimize board space by choosing smaller inductors. When choosing an inductor, there are three conditions that limit the minimum inductance; (1) providing adequate load current, (2) avoidance of subharmonic oscillation, and (3) supplying a minimum ripple current to avoid false tripping of the current comparator.

### Adequate Load Current

Small value inductors result in increased ripple currents and thus, due to the limited peak switch current, decrease the average current that can be provided to the load. In order to provide adequate load current, L should be at least:

$$L_{\text{BOOST}} > \frac{DC \cdot (V_{\text{IN}} - V_{\text{CESAT}})}{2 \cdot f_{\text{OSC}} \cdot \left( I_{\text{PK}} - \frac{V_{\text{OUT}} \cdot I_{\text{OUT}}}{V_{\text{IN}} \cdot \eta} \right)} \quad \text{Boost Topology}$$

or

$$L_{\text{DUAL}} > \frac{DC \cdot (V_{\text{IN}} - V_{\text{CESAT}})}{2 \cdot f_{\text{OSC}} \cdot \left( I_{\text{PK}} - \frac{|V_{\text{OUT}}| \cdot I_{\text{OUT}}}{V_{\text{IN}} \cdot \eta} - I_{\text{OUT}} \right)} \quad \text{SEPIC or Inverting Topologies}$$

where:

- $L_{\text{BOOST}}$  = L1 for Boost Topologies (see Figure 6)
- $L_{\text{DUAL}}$  = L1 = L2 for Coupled Dual Inductor Topologies (see Figures 7 and 8)
- $L_{\text{DUAL}}$  = L1 || L2 for Uncoupled Dual Inductor Topologies (see Figures 7 and 8)
- DC = Switch Duty Cycle (see Power Switch Duty Cycle section in Appendix)
- $I_{\text{PK}}$  = Maximum Peak Switch Current; Should Not Exceed 6A for a Combined SW1 + SW2 Current or 3.4A of SW1 Current (see Electrical Characteristics section.)
- $\eta$  = Power Conversion Efficiency (typically 90% for Boost and 85% for Dual Inductor Topologies at high currents)
- $f_{\text{OSC}}$  = Switching Frequency
- $I_{\text{OUT}}$  = Maximum Output Current

Negative values of  $L_{\text{BOOST}}$  or  $L_{\text{DUAL}}$  indicate that the output load current,  $I_{\text{OUT}}$ , exceeds the switch current limit capability of the LT3579.

### Avoiding Sub-Harmonic Oscillations

The LT3579's internal slope compensation circuit will prevent sub-harmonic oscillations that can occur when the duty cycle is greater than 50%, provided that the inductance exceeds a minimum value. In applications that operate with duty cycles greater than 50%, the inductance must be at least:

$$L_{\text{MIN}} = \frac{(V_{\text{IN}} - V_{\text{CESAT}}) \cdot (2 \cdot DC - 1)}{4A \cdot f_{\text{OSC}} \cdot (1 - DC)}$$

where:

- $L_{\text{MIN}}$  = L1 for Boost Topologies (see Figure 6)
- $L_{\text{MIN}}$  = L1 = L2 for Coupled Dual Inductor Topologies (see Figures 7 and 8)
- $L_{\text{MIN}}$  = L1 || L2 for Uncoupled Dual Inductor Topologies (see Figures 7 and 8)

## APPENDIX

### Maximum Inductance

Excessive inductance can reduce ripple current to levels that are difficult for the current comparator (A4 in the Block Diagram) to cleanly discriminate, thus causing duty cycle jitter and/or poor regulation. The maximum inductance can be calculated by:

$$L_{MAX} = \frac{(V_{IN} - V_{CESAT}) \cdot DC}{f_{OSC} \cdot 0.5A}$$

where:

- $L_{MAX}$  = L1 for Boost Topologies (see Figure 6)
- $L_{MAX}$  = L1 = L2 for Coupled Dual Inductor Topologies (see Figures 7 and 8)
- $L_{MAX}$  = L1 || L2 for Uncoupled Dual Inductor Topologies (see Figures 7 and 8)

### Inductor Current Rating

The inductor(s) must have a rating greater than its (their) peak operating current to prevent inductor saturation, which would result in catastrophic failure and efficiency losses. The maximum inductor current (considering start-up and steady-state conditions) is given by:

$$I_{L\_PEAK} = I_{LIM} + \frac{V_{IN} \cdot T_{MIN\_PROP}}{L}$$

where:

- $I_{L\_PEAK}$  = Peak Inductor Current in L1 for a Boost Topology, or the sum of the Peak Inductor Currents in L1 and L2 for Dual Inductor Topologies.
- $I_{LIM}$  = For Hard-Saturation Inductors, 9.4A with SW1 and SW2 Tied Together, or 5.1A with just SW1 used. For Soft-Saturation Inductors, 6A with SW1 and SW2 Tied Together, or 3.4A with just SW1 used.
- $T_{MIN\_PROP}$  = 100ns (Propagation Delay through the Current Feedback Loop).

Note that these equations offer conservative results for the required inductor current ratings. The current ratings could be lower for applications with light loads, provided the SS capacitor is sized appropriately to limit inductor currents at start-up.

### DIODE SELECTION

Schottky diodes, with their low forward voltage drops and fast switching speeds, are recommended for use with the LT3579. Choose a Schottky with low parasitic capacitance to reduce reverse current spikes through the power switch of the LT3579. The Diodes Inc. MBRM360 is a very good choice with a 60V reverse voltage rating and an average forward current of 3A.

### OUTPUT CAPACITOR SELECTION

Low ESR (equivalent series resistance) capacitors should be used at the output to minimize the output ripple voltage. Multilayer ceramic capacitors are an excellent choice, as they have an extremely low ESR and are available in very small packages. X5R or X7R type are preferred, as these materials retain their capacitance over wide voltage and temperature ranges. A 22 $\mu$ F to 47 $\mu$ F output capacitor is sufficient for most applications, but systems with low output currents may need only 4.7 $\mu$ F to 22 $\mu$ F. Always use a capacitor with a sufficient voltage rating. Many ceramic capacitors, particularly 0805 or 0603 case sizes, have greatly reduced capacitance at the desired output voltage. Tantalum polymer or OS-CON capacitors can be used, but it is likely that these capacitors will occupy more board area than a ceramic, and will have higher ESR with greater output ripple.

### INPUT CAPACITOR SELECTION

Ceramic capacitors make a good choice for the input decoupling capacitor,  $C_{VIN}$ , which should be placed as close as possible to the  $V_{IN}$  pin of the LT3579. This ensures that the voltage seen at the  $V_{IN}$  pin of the LT3579 remains a nearly flat DC voltage. A 1 $\mu$ F to 4.7 $\mu$ F input capacitor is sufficient for most applications.

A ceramic bypass capacitor,  $C_{PWR}$ , should also be placed as close as possible to the input of the inductor. This ensures that the inductor ripple current is supplied from the bypass capacitor and provides a nearly flat DC voltage to the input of the voltage converter. A 4.7 $\mu$ F to 10 $\mu$ F input power capacitor is sufficient for most applications.

## APPENDIX

Table 6 shows a list of several ceramic capacitor manufacturers. Consult the manufacturers for detailed information on their entire selection of ceramic parts.

**Table 6. Ceramic Capacitor Manufacturers**

TDK	www.tdk.com
Murata	www.murata.com
Taiyo Yuden	www.t-yuden.com

### PMOS SELECTION

An external PMOS, controlled by the LT3579's GATE pin, can be used to facilitate input or output disconnect. The GATE pin turns on the PMOS gradually during start-up (see Soft-Start of External PMOS in the Operation section), and turns the PMOS off when the LT3579 is in shutdown or in fault.

The use of the external PMOS, controlled by the GATE pin, is particularly beneficial when dealing with unintended output shorts in a boost regulator. In a conventional boost regulator, the inductor, Schottky diode, and power switches are susceptible to damage in the event of an output short to ground. Using an external PMOS in the boost regulator's power path (path from  $V_{IN}$  to  $V_{OUT}$ ) controlled by the GATE pin, will serve to disconnect the input from the output when the output has a short to ground, thereby helping save the IC, and the other components in the power path from damage.

The PMOS chosen must be capable of handling the maximum input or output current depending on whether the PMOS is used at the input (see Figure 12) or the output (see Figure 13).

Ensure that the PMOS is biased with enough source to gate voltage ( $V_{SG}$ ) to enhance the device into the triode mode of operation. The higher the  $V_{SG}$  voltage that biases the PMOS, the lower the  $R_{DS(ON)}$  of the PMOS, thereby lowering power dissipation in the device during normal operation, as well as improving the efficiency of the application in which the PMOS is used. The following equations show

the relationship between  $R_{GATE}$  (see Block Diagram) and the desired  $V_{SG}$  that the PMOS is biased with:

$$V_{SG} = \begin{cases} V_S \frac{R_{GATE}}{R_{GATE} + 2k\Omega} & \text{if } V_{GATE} < 2V \\ 933\mu A \cdot R_{GATE} & \text{if } V_{GATE} > 2V \end{cases}$$

When using a PMOS, it is advisable to configure the specific application for undervoltage lockout (see the Operations section). The goal is to have  $V_{IN}$  get to a certain minimum voltage where the PMOS has sufficient headroom to attain a high enough  $V_{SG}$ , which prevents it from entering the saturation mode of operation during start-up.

Figure 6 shows the PMOS connected in series with the output to act as an output disconnect during a fault condition. The Schottky diode from the  $V_{IN}$  pin to the GATE pin is optional and helps turn off the PMOS quicker in the event of hard shorts. The resistor from  $V_{IN}$  to the  $\overline{SHDN}$  pin sets a UVLO of 4V for this application.

Connecting the PMOS in series with the output offers certain advantages over connecting it in series with the input:

- Since the load current is always less than the input current for a boost converter, the current rating of the PMOS goes down when connected in series with the output as opposed to the input.
- A PMOS in series with the output can be biased with a higher overdrive voltage than a PMOS used in series with the input, since  $V_{OUT} > V_{IN}$ . This higher overdrive results in a lower  $R_{DS(ON)}$  for the PMOS, thereby improving the efficiency of the regulator.

In contrast, an input connected PMOS works as a simple hot-plug controller (covered in more detail in the Hot-Plug section). The input connected PMOS also functions as an inexpensive means of protecting against multiple output shorts in boost applications that synchronize the LT3579 with other compatible ICs (see Figure 12).

## APPENDIX

Table 7 shows a list of several discrete PMOS manufacturers. Consult the manufacturers for detailed information on their entire selection of PMOS devices.

**Table 7. Discrete PMOS Manufacturers**

Vishay	www.vishay.com
Fairchild Semiconductor	www.fairchildsemi.com
Central Semiconductor	www.centalsemi.com

### COMPENSATION – ADJUSTMENT

To compensate the feedback loop of the LT3579, a series resistor-capacitor network in parallel with an optional single capacitor must be connected from the  $V_C$  pin to GND. For most applications, choose a series capacitor in the range of 1nF to 10nF with 2.2nF being a good starting value. The optional parallel capacitor should range in value from 22pF to 180pF with 47pF being a good starting value. The compensation resistor,  $R_C$ , is usually in the range of 5k to 50k. A good technique to compensate a new application is to use a 100k $\Omega$  potentiometer in place of the series resistor  $R_C$ . With the series and parallel capacitors at 2.2nF and 47pF respectively, adjust the potentiometer while observing the transient response and the optimum value for  $R_C$  can be found. Figures 17a to 17c illustrate this process for the circuit of Figure 20 with a load current stepped between 0.7A and 1.5A. Figure 17a shows the transient response with  $R_C$  equal to 1k. The phase margin is poor as evidenced by the excessive ringing in the output voltage and inductor current. In Figure 17b, the value of  $R_C$  is increased to 3.5k, which results in a more damped response. Figure 17c shows the results when  $R_C$  is increased further to 8k. The transient response is nicely damped and the compensation procedure is complete.

### COMPENSATION – THEORY

Like all other current mode switching regulators, the LT3579 needs to be compensated for stable and efficient operation. Two feedback loops are used in the LT3579: a fast current loop which does not require compensation, and a slower voltage loop which does. Standard Bode plot analysis can be used to understand and adjust the voltage

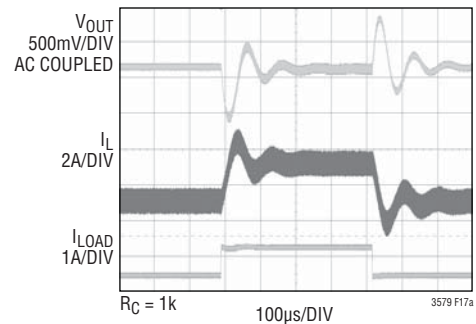

**Figure 17a. Transient Response Shows Excessive Ringing**

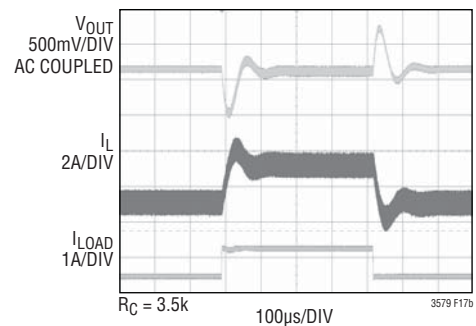

**Figure 17b. Transient Response Is Better**

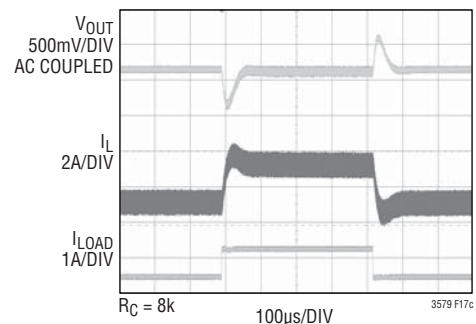
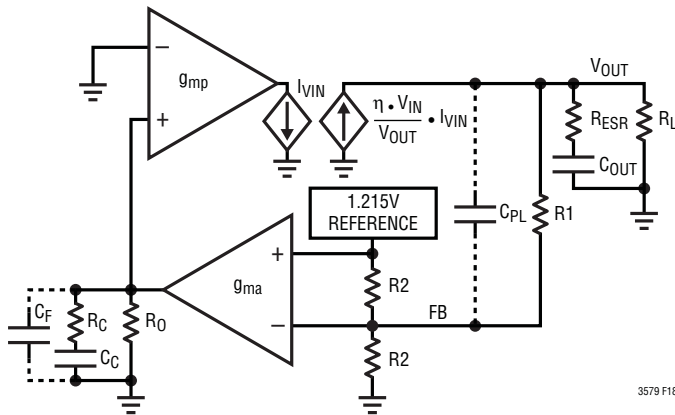

**Figure 17c. Transient Response Is Well Damped**

## APPENDIX

feedback loop.

As with any feedback loop, identifying the gain and phase contribution of the various elements in the loop is critical. Figure 18 shows the key equivalent elements of a boost converter. Because of the fast current control loop, the power stage of the IC, inductor and diode have been replaced by a combination of the equivalent transconductance amplifier  $g_{mp}$  and the current controlled current source (which converts  $I_{VIN}$  to  $\frac{\eta V_{IN}}{V_{OUT}} I_{VIN}$ ).  $G_{mp}$  acts as a current



$C_C$ : COMPENSATION CAPACITOR  
 $C_{OUT}$ : OUTPUT CAPACITOR  
 $C_{PL}$ : PHASE LEAD CAPACITOR  
 $C_F$ : HIGH FREQUENCY FILTER CAPACITOR  
 $g_{ma}$ : TRANSCONDUCTOR AMPLIFIER INSIDE IC  
 $g_{mp}$ : POWER STAGE TRANSCONDUCTANCE AMPLIFIER  
 $R_C$ : COMPENSATION RESISTOR  
 $R_L$ : OUTPUT RESISTANCE DEFINED AS  $V_{OUT}/I_{LOADMAX}$   
 $R_0$ : OUTPUT RESISTANCE OF  $g_{ma}$   
 $R_1, R_2$ : FEEDBACK RESISTOR DIVIDER NETWORK  
 $R_{ESR}$ : OUTPUT CAPACITOR ESR  
 $\eta$ : CONVERTER EFFICIENCY (~90% AT HIGHER CURRENTS)

Figure 18. Boost Converter Equivalent Model

source where the peak input current,  $I_{VIN}$ , is proportional to the  $V_C$  voltage.

Note that the maximum output currents of  $g_{mp}$  and  $g_{ma}$

are finite. The output of the  $g_{mp}$  stage is limited by the minimum switch current limit (see Electrical Specifications) and  $g_{ma}$  is nominally limited to about  $\pm 12\mu A$ .

From Figure 18, the DC gain, poles and zeros can be calculated as follows:

DC Gain:

$$A_{DC} = g_{ma} \cdot R_0 \cdot g_{mp} \cdot \eta \cdot \frac{V_{IN}}{V_{OUT}} \cdot \frac{R_L}{2} \cdot \frac{0.5R_2}{R_1 + 0.5R_2}$$

$$\text{Output Pole: } P1 = \frac{2}{2 \cdot \pi \cdot R_L \cdot C_{OUT}}$$

$$\text{Error Amp Pole: } P2 = \frac{1}{2 \cdot \pi \cdot (R_0 + R_C) \cdot C_C}$$

$$\text{Error Amp Zero: } Z1 = \frac{1}{2 \cdot \pi \cdot R_C \cdot C_C}$$

$$\text{ESR Zero: } Z2 = \frac{1}{2 \cdot \pi \cdot R_{ESR} \cdot C_{OUT}}$$

$$\text{RHP Zero: } Z3 = \frac{V_{IN}^2 \cdot R_L}{2 \cdot \pi \cdot V_{OUT}^2 \cdot L}$$

$$\text{High Frequency Pole: } P3 > \frac{f_s}{3}$$

$$\text{Phase Lead Zero: } Z4 = \frac{1}{2 \cdot \pi \cdot R_1 \cdot C_{PL}}$$

$$\text{Phase Lead Pole: } P4 = \frac{1}{2 \cdot \pi \cdot \frac{R_1 \cdot 0.5R_2}{R_1 + 0.5R_2} \cdot C_{PL}}$$

Error Amp Filter Pole:

$$P5 = \frac{1}{2 \cdot \pi \cdot \frac{R_C \cdot R_0}{R_C + R_0} \cdot C_F}, C_F < \frac{C_C}{10}$$

## APPENDIX

The current mode zero (Z3) is a right half plane zero which can be an issue in feedback control design, but is manageable with proper external component selection.

Using the circuit in Figure 20 as an example, Table 8 shows the parameters used to generate the Bode plot shown in Figure 19.

**Table 8. Bode Plot Parameters**

PARAMETER	VALUE	UNITS	COMMENT
$R_L$	7	$\Omega$	Application Specific
$C_{OUT}$	30	$\mu F$	Application Specific
$R_{ESR}$	2	$m\Omega$	Application Specific
$R_0$	305	$k\Omega$	Not Adjustable
$C_C$	2200	$pF$	Adjustable
$C_F$	47	$pF$	Optional/Adjustable
$C_{PL}$	0	$pF$	Optional/Adjustable
$R_C$	8	$k\Omega$	Adjustable
$R_1$	130	$k\Omega$	Adjustable
$R_2$	14.6	$k\Omega$	Not Adjustable
$V_{OUT}$	12	V	Application Specific
$V_{IN}$	5	V	Application Specific
$g_{ma}$	250	$\mu mho$	Not Adjustable
$g_{mp}$	28	$mho$	Not Adjustable
$L$	2.2	$\mu H$	Application Specific
$f_{OSC}$	1.0	MHz	Adjustable

From Figure 19, the phase is  $-134^\circ$  when the gain reaches 0dB giving a phase margin of  $46^\circ$ . The crossover frequency

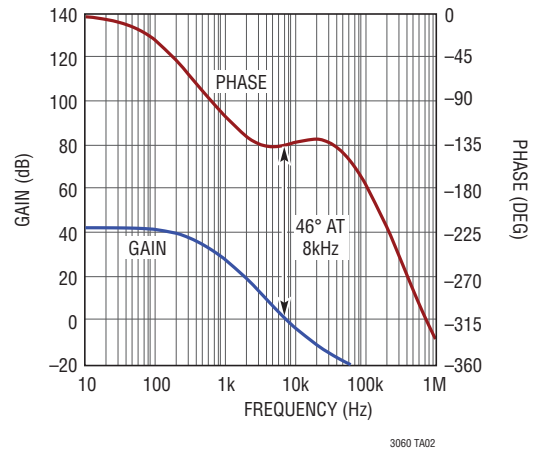

**Figure 19. Bode Plot for Example Boost Converter**

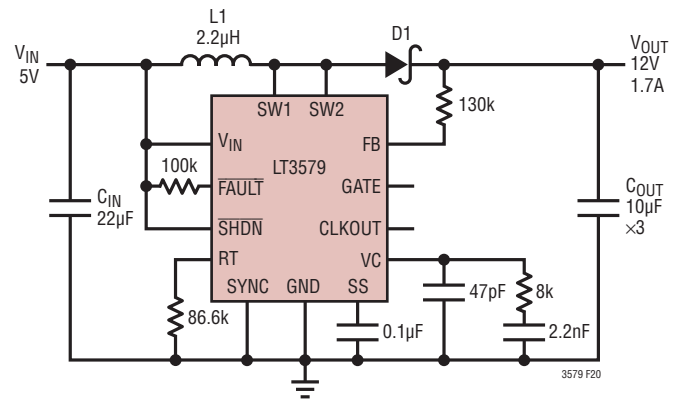
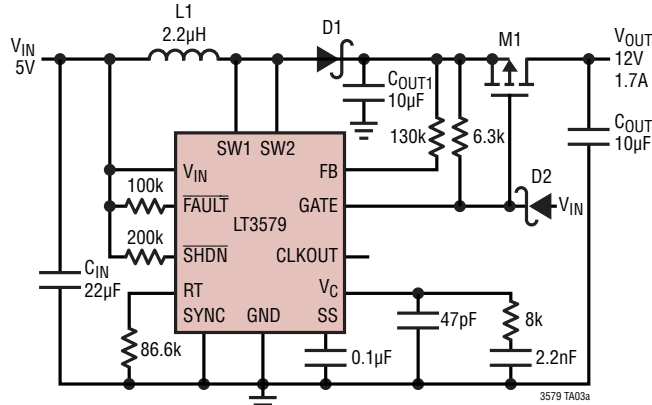

**Figure 20. 5V to 12V Boost Converter**



# TYPICAL APPLICATION

## 1MHz, 5V to 12V Boost Converter can Survive Output Shorts



- C<sub>IN</sub>: 22µF, 16V, X7R, 1210
- C<sub>OUT1</sub>, C<sub>OUT</sub>: 10µF, 25V, X7R, 1210
- D1: VISHAY SSB43L
- D2: CENTRAL SEMI CMDSH-3TR
- L1: WÜRTH WE-PD 744771002
- M1: SILICONIX SI7123DN

### Efficiency and Power Loss

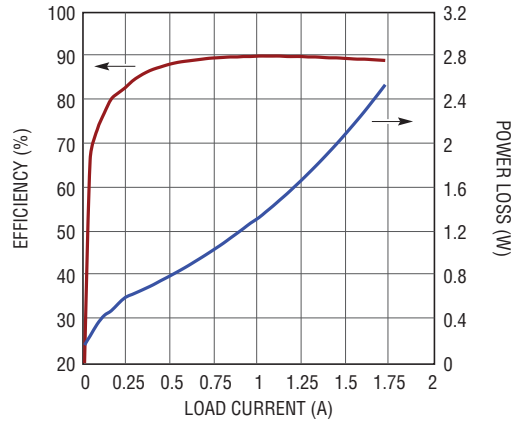

3579 TA03

### Output Short

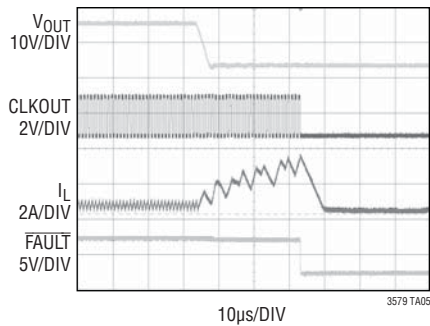

3579 TA05

### Transient Response with 0.7A to 1.5A to 0.7A Output Load Step

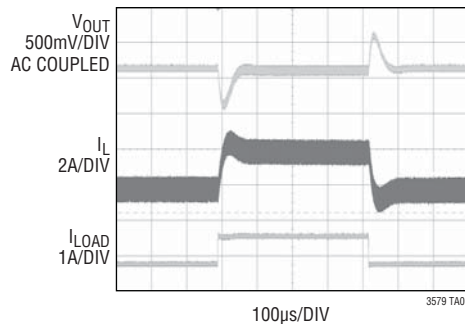

3579 TA06

## TYPICAL APPLICATION

### 500kHz SEPIC Converter Generates 3.3V from a 3V to 33V Input

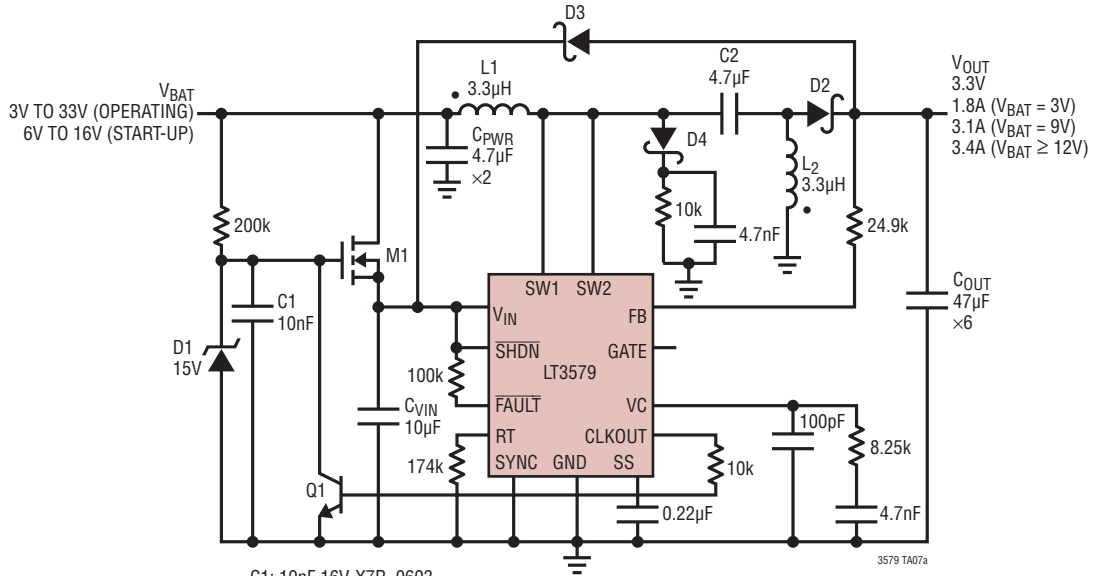

- C1: 10nF, 16V, X7R, 0603
- C<sub>VIN</sub>: 10µF, 16V, X7R, 1206
- C<sub>PWR</sub>, C2: 4.7µF, 50V, X7R, 1210
- C<sub>OUT</sub>: 47µF, 6.3V, X7R, 1210
- D1: CENTRAL SEMI CMHZ5245B-LTZ
- D2: VISHAY SS5P6
- D3: CENTRAL SEMI CMMSH2-40
- D4: CENTRAL SEMI CMMSH2-40
- L1, L2: WÜRTH WE-DD 744870003
- M1: 2N7002
- Q1: MMBT3904

Efficiency and Power Loss

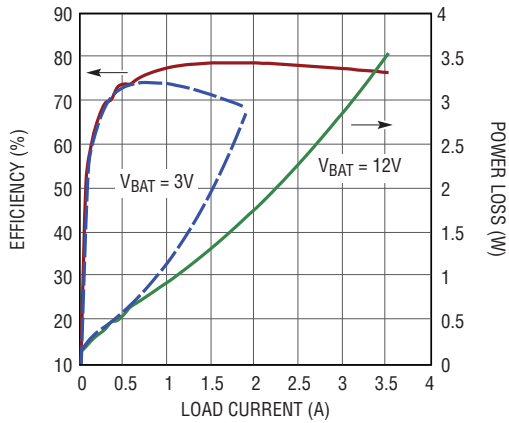

Transient Response with 9V to 33V to 9V V<sub>BAT</sub> Glitch (R<sub>LOAD</sub> = 1.5Ω)

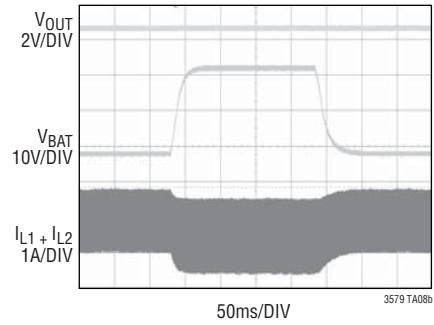



# TYPICAL APPLICATION

## 1.2MHz, 5V to -12V Inverting Converter

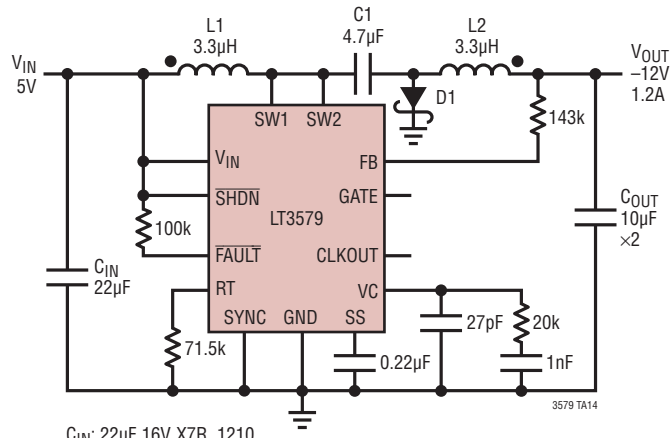

$C_{IN}$ : 22µF, 16V, X7R, 1210  
 $C_1$ : 4.7µF, 25V, X7R, 1206  
 $C_{OUT}$ : 10µF, 25V, X7R, 1210  
 D1: DIODES INC B230A  
 L1, L2: COOPER BUSSMANN DRQ125-3R3-R

Efficiency and Power Loss

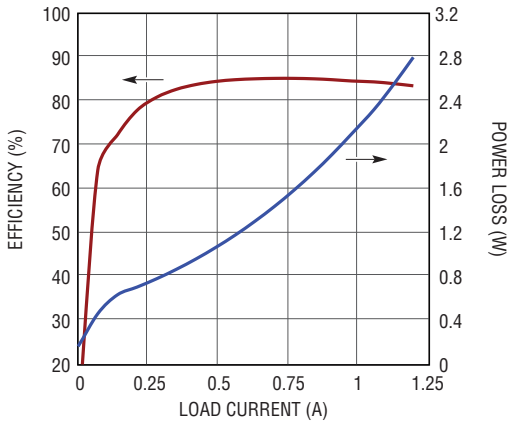

3579 TA15

Transient Response with 0.5A to 1A to 0.5A Output Load Step

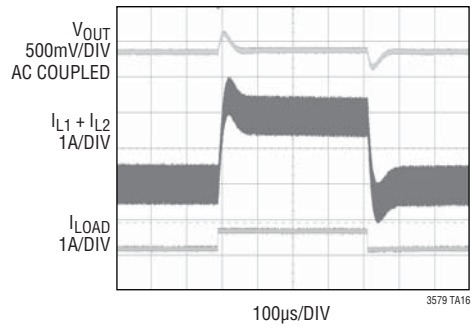

3579 TA16

## TYPICAL APPLICATION

### VFD (Vacuum Fluorescent Display) Power Supply Switches at 1MHz Danger High Voltage! Operation by High Voltage Trained Personnel Only

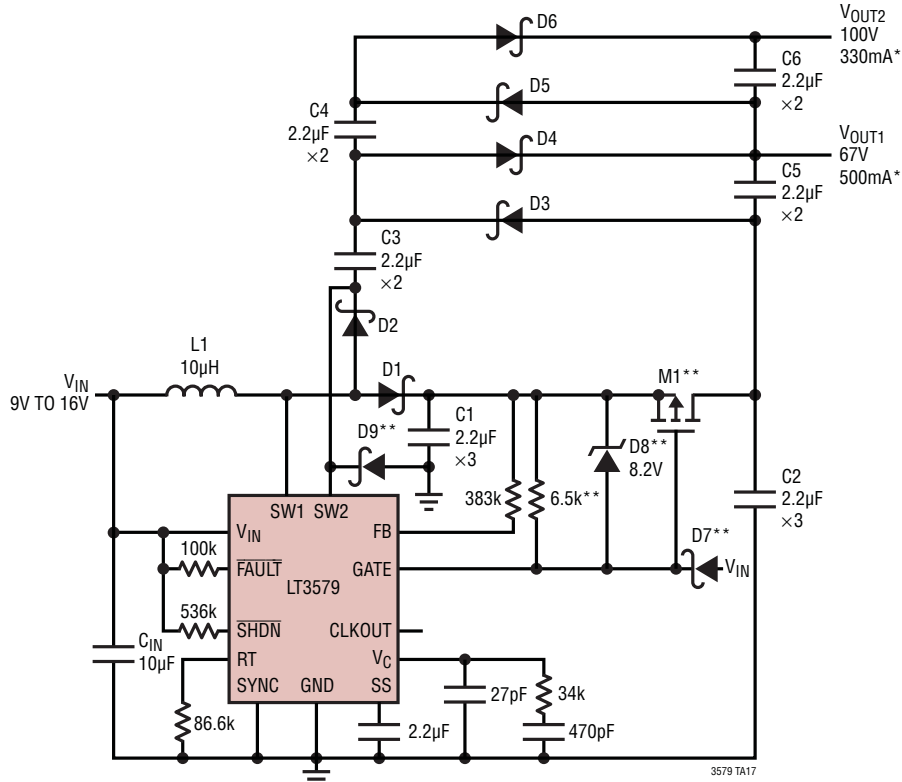

- C<sub>IN</sub>: 10µF 25V, X7R, 1210
- C1-C6: 2.2µF 50V, X7R, 1210
- D1-D6: DIODES INC SBR2A40P1
- D7: CENTRAL SEMI CMDSH-3TR
- D8: CENTRAL SEMI CMDZ5237B-LTZ
- D9: DIODES INC MBRM360
- L1: WÜRTH WE-PD 7447710
- M1: SILICONIX SI7461DP

- \*MAX TOTAL OUTPUT POWER
- 22W (V<sub>IN</sub> = 9V)
- 27W (V<sub>IN</sub> = 12V)
- 33W (V<sub>IN</sub> = 16V)
- \*\*OPTIONAL FOR OUTPUT SHORT CIRCUIT PROTECTION

Efficiency and Power Loss (V<sub>IN</sub> = 12V)

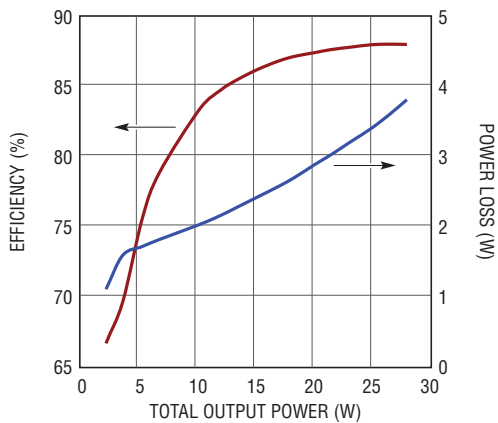

Cycle-to-Cycle

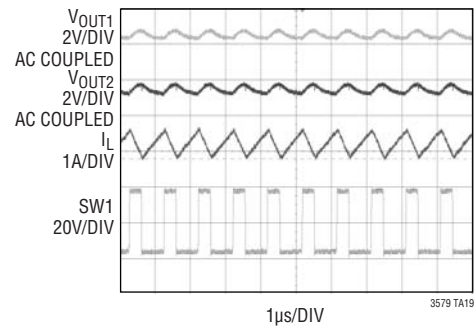

TYPICAL APPLICATION

1MHz, 5V to ±12V Converter

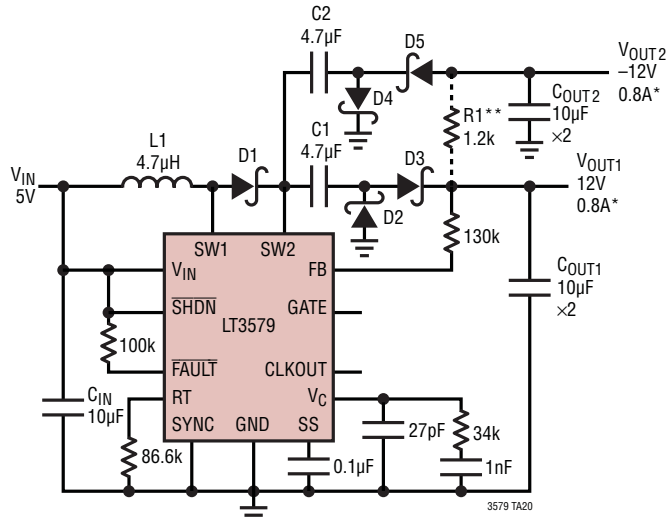

- C<sub>IN</sub>: 10µF 16V, X7R, 1206
  - C<sub>1</sub>, C<sub>2</sub>: 4.7µF, 25V, X7R, 1206
  - C<sub>OUT1</sub>, C<sub>OUT2</sub>: 10µF, 25V, X7R, 1210
  - D1-D5: DIODES INC SBR2A40P1
  - L1: VISHAY IHLP-2525CZ-01-4R7
  - R1: 1.2k, 2W
- \*MAX TOTAL OUTPUT POWER = 9.6W

\*\*IF DRIVING ASYMMETRICAL LOADS, PLACE A 1.2k, 2W RESISTOR FROM THE +12V OUTPUT TO THE -12V OUTPUT FOR IMPROVED LOAD REGULATION OF THE -12V OUTPUT.

Efficiency and Power Loss

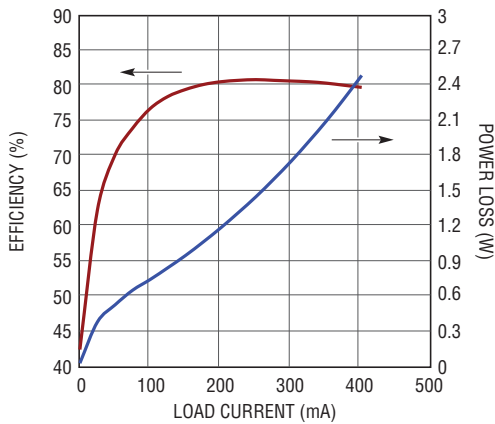

3579 TA21

Transient Response with 0.15A to 0.35A to 0.15A Symmetrical Output Load Step

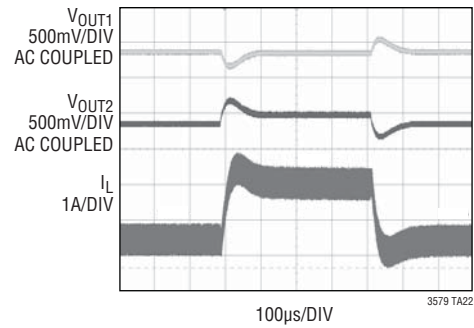

3579 TA22

## TYPICAL APPLICATION

1MHz, 2-Phase Converter Generates a 24V Output from a 8V to 16V Input and Uses Small Components

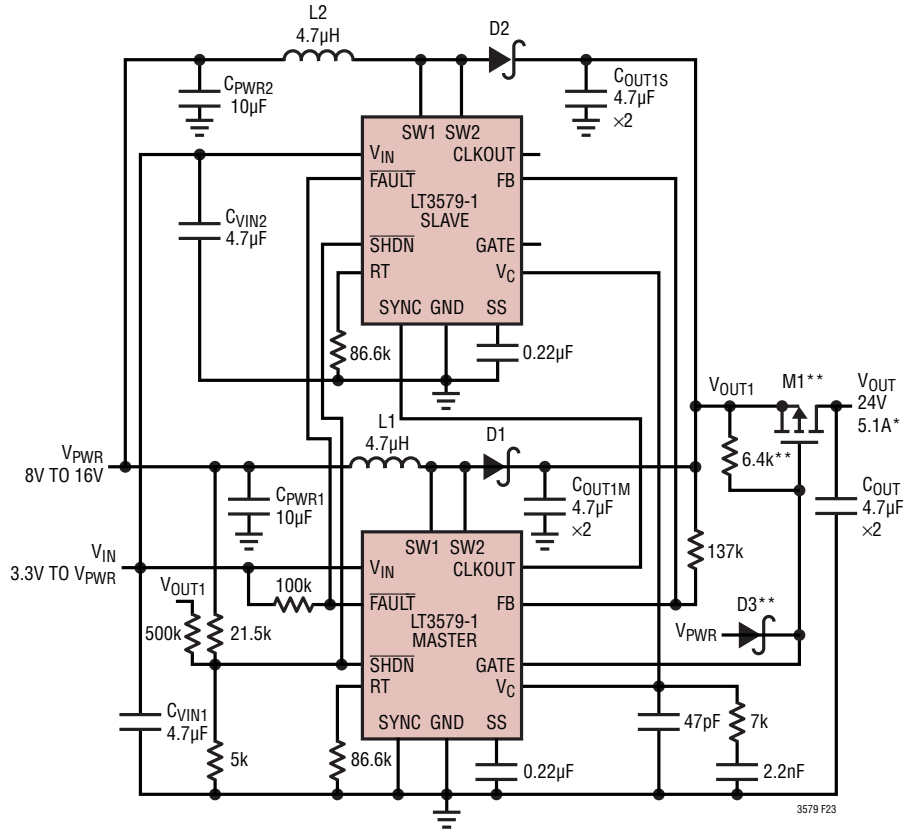

$C_{PWR1}$ ,  $C_{PWR2}$ : 10 $\mu$ F, 25V, X7R, 1210  
 $C_{VIN1}$ ,  $C_{VIN2}$ : 4.7 $\mu$ F, 25V, X7R, 1206  
 $C_{OUT1M}$ ,  $C_{OUT1S}$ ,  $C_{OUT}$ : 4.7 $\mu$ F, 50V, X5R, 1210  
 D1, D2: CENTRAL SEMI CTL5H5-40M833  
 D3: CENTRAL SEMI CTL5H1-40M563  
 L1, L2: VISHAY IHLP-2525CZ-01-4R7  
 M1: SILICONIX SI7461DP

### \* MAX OUTPUT CURRENT

	$V_{PWR} = 8V$	$V_{PWR} = 12V$	$V_{PWR} = 16V$
$V_{IN} = 3.3V$ TO 5V	2.4A	3.7A	5.1A
$V_{IN} = V_{PWR}$	2.2A	3.1A	3.9A

\*\* OPTIONAL FOR OUTPUT SHORT CIRCUIT PROTECTION

### Efficiency and Power Loss ( $V_{PWR} = 12V$ )

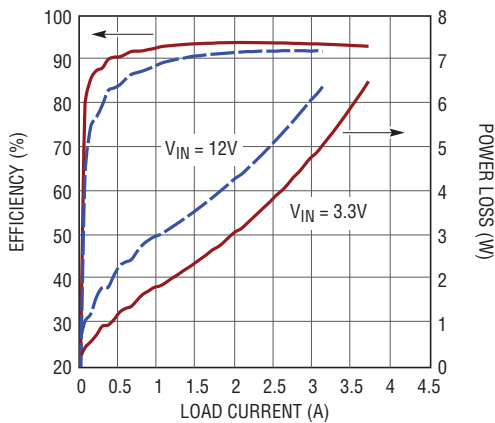

3579 TA24

### Transient Response with 1.5A to 3.25A to 1.5A Output Load Step ( $V_{PWR} = 12V$ and $V_{IN} = 3.3V$ )

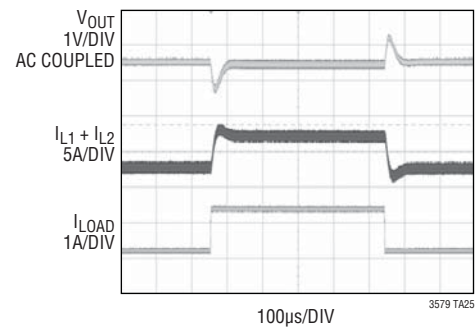

3579 TA25

# TYPICAL APPLICATION

2MHz, Boost Converter with Output Disconnect Generates a 5V Output from 2.8V to 4.2V Input

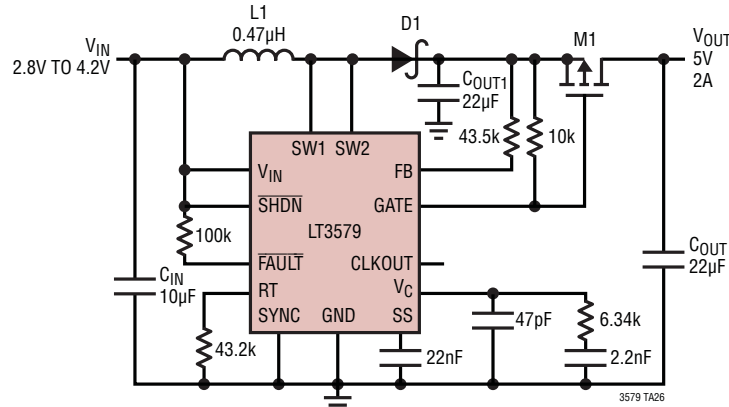

- C<sub>IN</sub>: 10µF, 16V, X7R, 1206
- C<sub>OUT1</sub>, C<sub>OUT</sub>: 22µF, 16V, X7R, 1210
- D1: CENTRAL SEMI CTL5H3-30M833
- L1: VISHAY IHLP-2020BZ-01-R47
- M1: SILICONIX SI7123DN

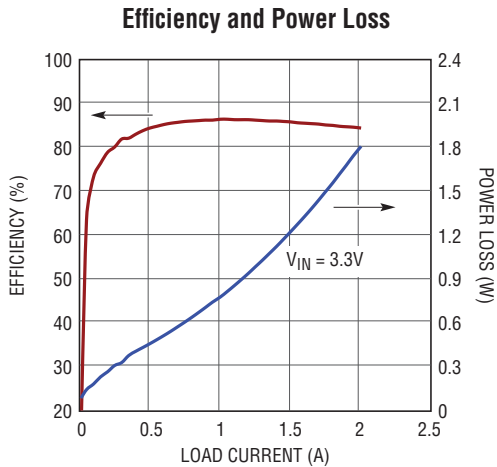

Transient Response with 0.8A to 1.8A to 0.8A Output Load Step (VIN = 3.3V)

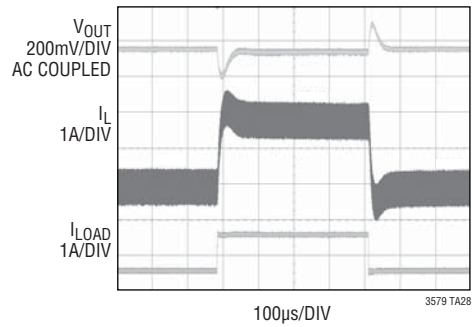

**PACKAGE DESCRIPTION**

**FE Package  
20-Lead Plastic TSSOP (4.4mm)  
(Reference LTC DWG # 05-08-1663)  
Exposed Pad Variation CB**

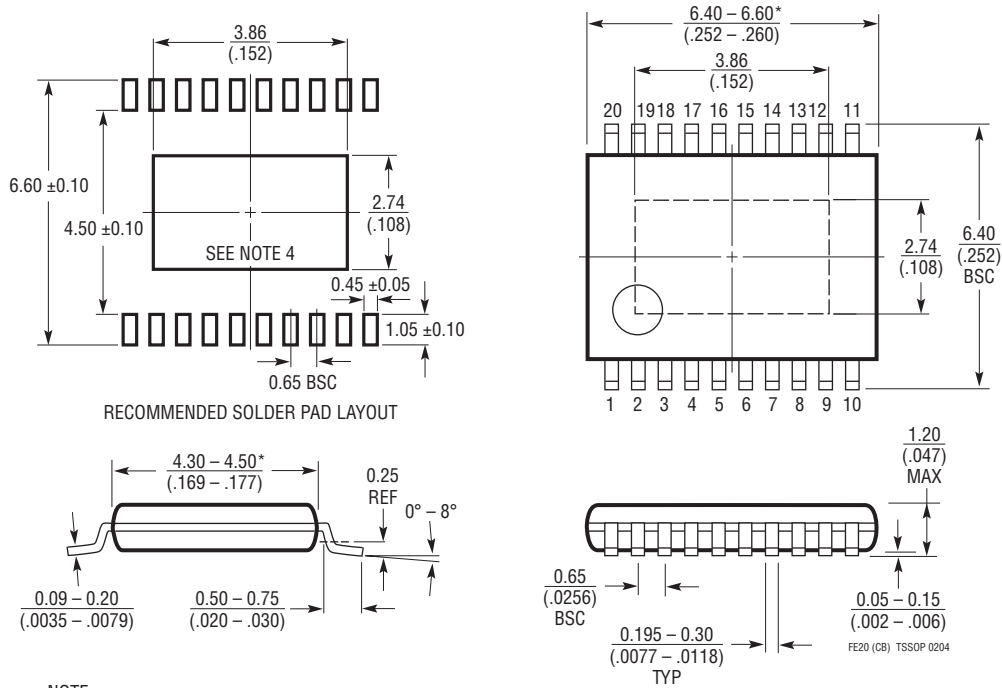

- NOTE:
1. CONTROLLING DIMENSION: MILLIMETERS
  2. DIMENSIONS ARE IN  $\frac{\text{MILLIMETERS}}{\text{INCHES}}$
  3. DRAWING NOT TO SCALE
  4. RECOMMENDED MINIMUM PCB METAL SIZE FOR EXPOSED PAD ATTACHMENT
- \*DIMENSIONS DO NOT INCLUDE MOLD FLASH. MOLD FLASH SHALL NOT EXCEED 0.150mm (.006) PER SIDE

# PACKAGE DESCRIPTION

**UFD Package**  
**20-Lead Plastic QFN (4mm × 5mm)**  
 (Reference LTC DWG # 05-08-1711 Rev B)

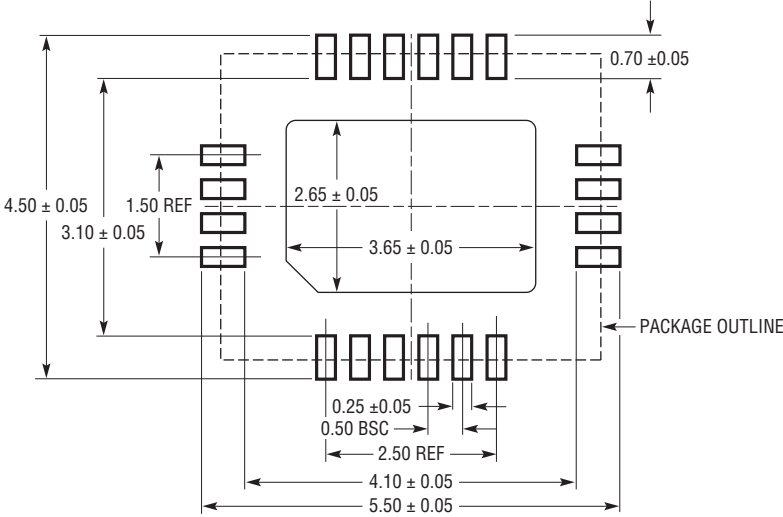

RECOMMENDED SOLDER PAD PITCH AND DIMENSIONS  
 APPLY SOLDER MASK TO AREAS THAT ARE NOT SOLDERED

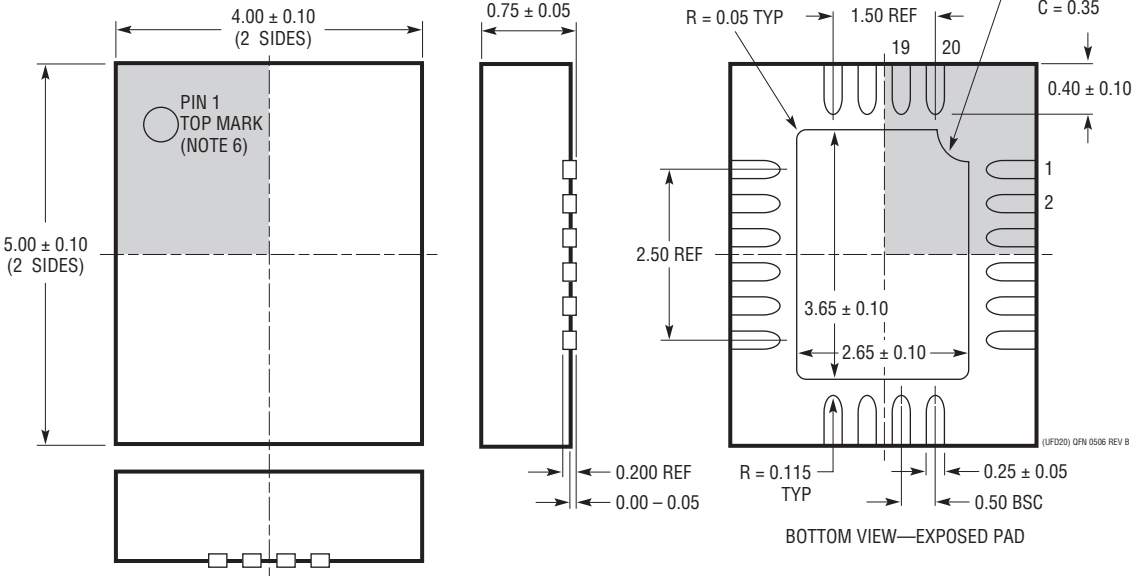

- NOTE:
1. DRAWING PROPOSED TO BE MADE A JEDEC PACKAGE OUTLINE MO-220 VARIATION (WXXX-X).
  2. DRAWING NOT TO SCALE
  3. ALL DIMENSIONS ARE IN MILLIMETERS
  4. DIMENSIONS OF EXPOSED PAD ON BOTTOM OF PACKAGE DO NOT INCLUDE MOLD FLASH. MOLD FLASH, IF PRESENT, SHALL NOT EXCEED 0.15mm ON ANY SIDE
  5. EXPOSED PAD SHALL BE SOLDER PLATED
  6. SHADED AREA IS ONLY A REFERENCE FOR PIN 1 LOCATION ON THE TOP AND BOTTOM OF PACKAGE

# LT3579/LT3579-1

## TYPICAL APPLICATION

1MHz SEPIC Converter Generates a 12V Output from a 9V to 16V Input

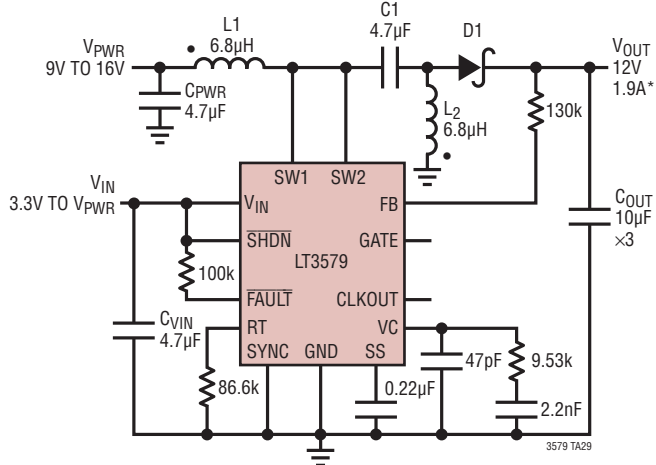

C<sub>PWR</sub>: 4.7µF, 25V, X7R, 1206  
 C<sub>VIN</sub>: 4.7µF, 25V, X7R, 1206  
 C1: 4.7µF, 25V, X7R, 1206  
 C<sub>OUT</sub>: 10µF, 25V, X7R, 1210  
 D1: DIODES INC MBRM360  
 L1, L2: COOPER BUSSMANN DRQ125-6R8-R

**\*MAX OUTPUT CURRENT**

	V <sub>PWR</sub> = 9V	V <sub>PWR</sub> = 12V
V <sub>IN</sub> = 3.3V TO 5V	1.6A	1.9A
V <sub>IN</sub> = V <sub>PWR</sub>	1.4A	1.4A

LINE REGULATION (V<sub>IN</sub> = 5V, I<sub>OUT</sub> = 1A) = 0.017%/V  
 LOAD REGULATION (V<sub>PWR</sub> = 12V, V<sub>IN</sub> = 5V) = -0.23%/A

### Efficiency and Power Loss

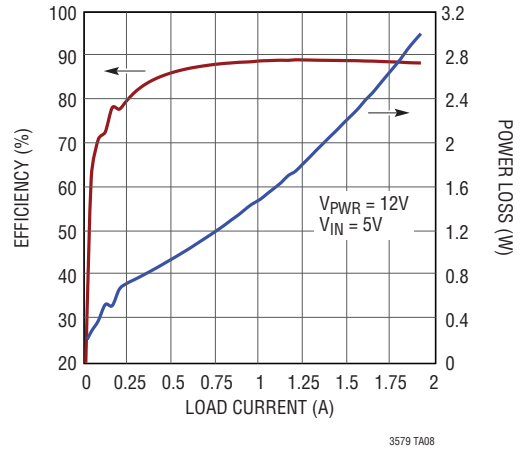

3579 TA08

## RELATED PARTS

PART NUMBER	DESCRIPTION	COMMENTS
LT3581	3.3A (I <sub>SW</sub> ), 42V, 2.5MHz, High Efficiency Step-Up DC/DC Converter	V <sub>IN</sub> : 2.5V to 22V, V <sub>OUT(MAX)</sub> = 42V, I <sub>Q</sub> = 1.9mA, I <sub>SD</sub> = < 1µA, 4mm × 3mm DFN-14, MSOP-16E
LT3580	2A (I <sub>SW</sub> ), 42V, 2.5MHz, High Efficiency Step-Up DC/DC Converter	V <sub>IN</sub> : 2.5V to 32V, V <sub>OUT(MAX)</sub> = 42V, I <sub>Q</sub> = 1mA, I <sub>SD</sub> = < 1µA, 3mm × 3mm DFN-8, MSOP-8E
LT3479	3A (I <sub>SW</sub> ), 40V, 3.5MHz, High Efficiency Step-Up DC/DC Converter	V <sub>IN</sub> : 2.5V to 24V, V <sub>OUT(MAX)</sub> = 40V, I <sub>Q</sub> = 5mA, I <sub>SD</sub> = < 1µA, 4mm × 3mm DFN-14, TSSOP-16E

35791f