

FEATURES

- True Color PWM™ Dimming Delivers Up to 5000:1 Dimming Ratio (In Boost Configuration)
- LED Current Regulation with High-Side Sense
- VADJ Pin Accurately Sets LED Current Sense Threshold Over Range 10mV to 120mV
- Four Independent Driver Channels with 1.5A, 36V Internal NPN Switches
- Frequency Adjust Pin: 200kHz to 2MHz
- High Efficiency Conversion = Up to 96%
- Open LED Protection
- Low Quiescent Current
 - 22mA in Active Mode
 - <10µA in Shutdown Mode
- Wide V_{IN} Range: 2.8V to 16V
- Thermally Enhanced, 38-Lead, 5mm × 7mm QFN Package

APPLICATIONS

- RRGB Lighting
- Automotive and Avionic Lighting
- TFT LCD Backlighting
- Constant-Current Sources

DESCRIPTION

The LT®3476 is a quad output DC/DC converter designed to operate as a constant-current source for driving high current LEDs. A fixed frequency, current mode architecture results in stable operation over a wide range of supply and output voltages. A frequency adjust pin allows the user to program switching frequency between 200kHz and 2MHz to optimize efficiency and external component size.

The LT3476 senses output current at the high side of the LED. High side current sensing is the most flexible scheme for driving LEDs, allowing buck, boost or buck-boost configurations. Each current monitor threshold is trimmed to within 2.5% at the full scale of 105mV. With an external sense resistor, the user programs the output current range of each channel. Each of the four regulators is independently operated by that channel's PWM signal. This PWM feature allows precise adjustment of the color mixing or dimming ratio of the LED source. Dimming ratios up to 1000:1 can be achieved.

LT, LT, LTC and LTM are registered trademarks of Linear Technology Corporation. True Color PWM is a trademark of Linear Technology Corporation. All other trademarks are the property of their respective owners.

TYPICAL APPLICATION

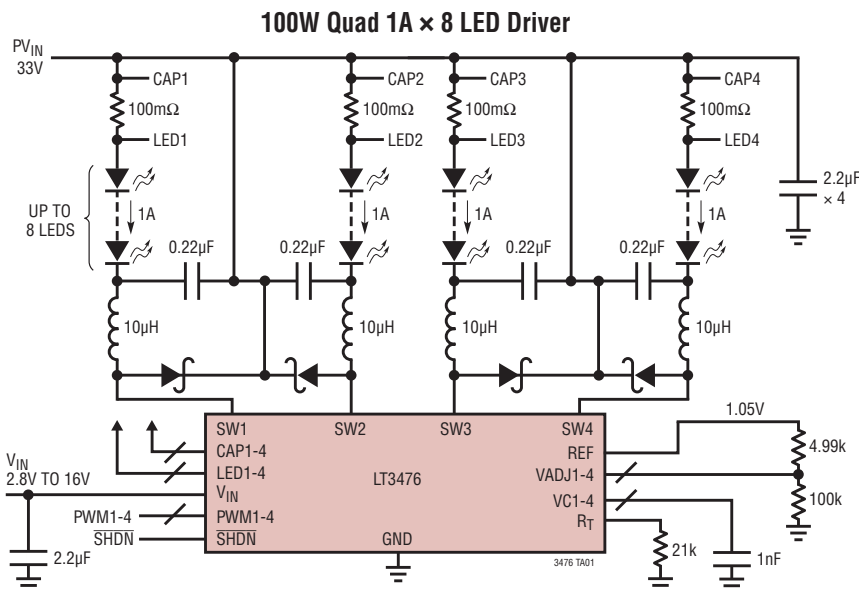

1000:1 PWM Dimming at 100Hz

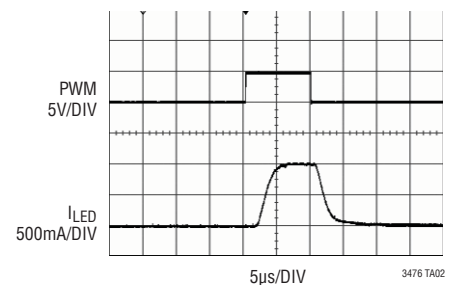

LT3476

ABSOLUTE MAXIMUM RATINGS

(Note 1)

V_{IN}	16V
PWM1-4, SHDN	16V
SW1-4, LED1-4, CAP1-4	36V
REF, R_T , V_{ADJ1-4} , V_C1-4	2V
Operating Temperature Range (Note 2)....	-40°C to 85°C
Maximum Junction Temperature.....	125°C
Storage Temperature Range.....	-65°C to 125°C
Lead Temperature	300°C

PIN CONFIGURATION

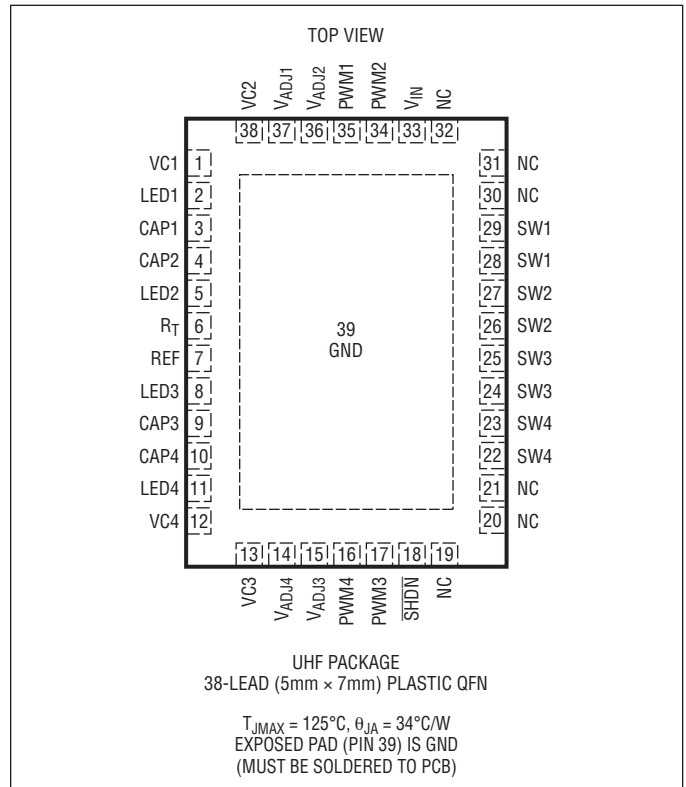

ORDER INFORMATION

LEAD FREE FINISH	TAPE AND REEL	PART MARKING	PACKAGE DESCRIPTION	TEMPERATURE RANGE
LT3476EUHF#PBF	LT3476EUHF#TRPBF	3476	38-Lead (5mm × 7mm) Plastic QFN	-40°C to 85°C
LEAD BASED FINISH	TAPE AND REEL	PART MARKING	PACKAGE DESCRIPTION	TEMPERATURE RANGE
LT3476EUHF	LT3476EUHF#TR	3476	38-Lead (5mm × 7mm) Plastic QFN	-40°C to 85°C

Consult LTC Marketing for parts specified with wider operating temperature ranges.

For more information on lead free part marking, go to: <http://www.linear.com/leadfree/>

For more information on tape and reel specifications, go to: <http://www.linear.com/tapeandreeel/>

ELECTRICAL CHARACTERISTICS The ● denotes the specifications which apply over the full operating temperature range, (Note 3) otherwise specifications are at $T_A = 25^{\circ}\text{C}$. SW1-4 = 5V, $V_{IN} = 3.3\text{V}$, SHDN = 3.3V, $R_T = 21\text{k}$ to GND, PWM1-4 = 3.3V, $V_{ADJ1-4} = \text{REF}$, CAP1-4 = 5V, unless otherwise noted.

PARAMETER	CONDITIONS	MIN	TYP	MAX	UNITS
V_{IN} Operating Range		2.8		16	V
Full-Scale LED Current Monitor Threshold	Over CAP1-4/LED1-4 Operating Range	102 100	105	107 108	mV mV
One-Tenth Scale LED Current Monitor Threshold	$V_{ADJ1-4} = 100\text{mV}$	8	12	16	mV
CAP1-4/LED1-4 Operating Range		2.2		36	V
REF Output Voltage	$10\mu\text{A} \geq I_{REF} \geq -200\mu\text{A}$	1.032	1.050	1.063	V
REF Line Regulation	$2.8\text{V} \leq V_{IN} \leq 16\text{V}$		0.003		%/V
Quiescent Current in Shutdown	SHDN = 0V		0.1	10	μA

3476fa

ELECTRICAL CHARACTERISTICS The ● denotes the specifications which apply over the full operating temperature range, (Note 3) otherwise specifications are at $T_A = 25^\circ\text{C}$. SW1-4 = 5V, $V_{IN} = 3.3\text{V}$, $\overline{\text{SHDN}} = 3.3\text{V}$, $R_T = 21\text{k}$ to GND, PWM1-4 = 3.3V, $V_{\text{ADJ1-4}} = \text{REF}$, CAP1-4 = 5V, unless otherwise noted.

PARAMETER	CONDITIONS	MIN	TYP	MAX	UNITS
Quiescent Current Idle	PWM1-4 = 0V		5.5		mA
Quiescent Current Active (Not Switching)	VC1-4 = 0V		22	30	mA
Switching Frequency	$R_T = 8.25\text{k}$	1700	2000	2300	kHz
	$R_T = 21\text{k}$	850	1000	1150	kHz
	$R_T = 140\text{k}$	160	200	240	kHz
Nominal R_T Pin Voltage			1.26		V
Maximum Duty Cycle	$R_T = 8.25\text{k}$ (2MHz)		76		%
	$R_T = 21\text{k}$ (1MHz)	84	90		%
	$R_T = 140\text{k}$ (200kHz)		98		%
$V_{\text{ADJ1-4}}$ Input Bias Current	Current Out of Pin	-10	20	100	nA
VC1-4 Idle Input Bias Current	PWM1-4 = 0V	-20	0	20	nA
EAMP GM ($\Delta I_{VC}/\Delta V_{\text{CAP-LED}}$)			200		μS
VC Output Impedance			3		$\text{M}\Omega$
SW1-4 Current Limit	Static Test	1.5	2	2.5	A
SW1-4 V_{CESAT}	$I_{\text{SW}} = 1.3\text{A}$ to GND		350		mV
SW1-4 Leakage Current	$\overline{\text{SHDN}} = 0\text{V}$		0.1	5	μA
CAP1-4 Overvoltage Protect Threshold		33.5	35		V
CAP1-4/LED1-4 Idle Input Bias Current	PWM1-4 < 0.4V, CAP = LED = 5V			100	nA
CAP1-4/LED1-4 Input Bias Current	CAP = LED = 5V		70		μA
$\overline{\text{SHDN}}$ Input Low Voltage				0.4	V
$\overline{\text{SHDN}}$ Input High Voltage		1.5			V
$\overline{\text{SHDN}}$ Pin Current			16	30	μA
PWM1-4 Input Low Voltage				0.4	V
PWM1-4 Input High Voltage		1.5			V
PWM1-4 Pin Current			50	100	μA

Note 1: Stresses beyond those listed under Absolute Maximum Ratings may cause permanent damage to the device. Exposure to any Absolute Maximum Rating condition for extended periods may affect device reliability and lifetime.

Note 2: This IC includes overtemperature protection that is intended to protect the device during momentary overload conditions. Junction temperature will exceed 125°C when overtemperature protection is active. Continuous operation above the specified maximum operating junction temperature may impair device reliability.

Note 3: The LT3476E is guaranteed to meet specifications from 0°C to 85°C . Specifications over the -40°C to 85°C operating temperature range are assured by design, characterization and correlation with statistical process controls.

TYPICAL PERFORMANCE CHARACTERISTICS $T_A = 25^\circ\text{C}$, unless otherwise noted.

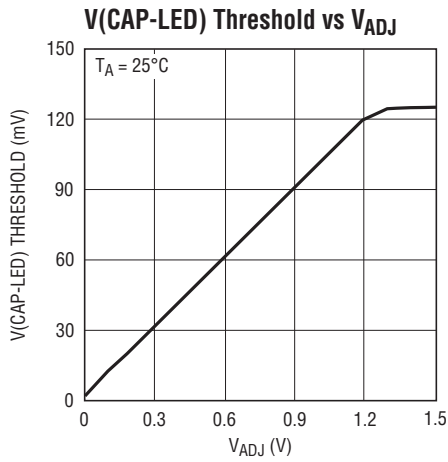

3476 G01

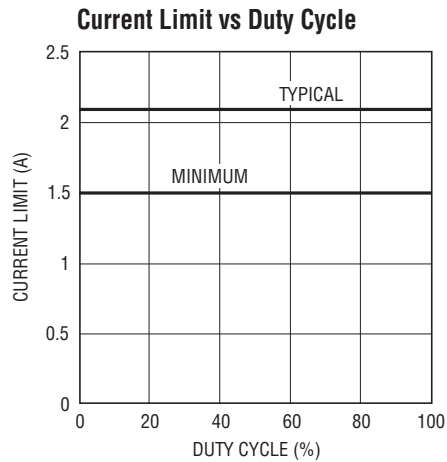

3476 G02

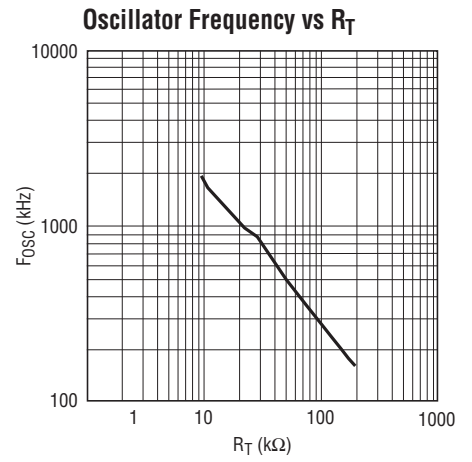

3476 G03

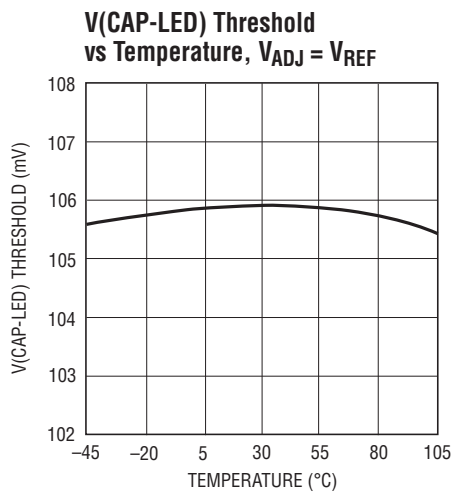

3476 G04

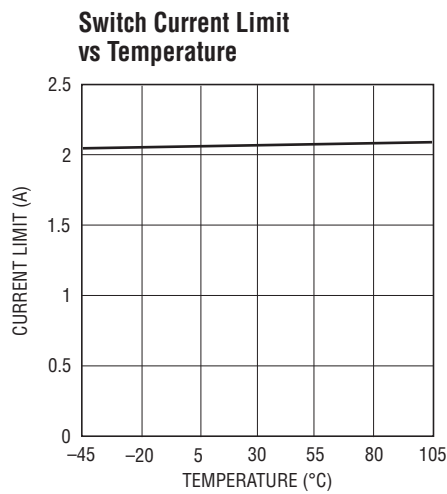

3476 G05

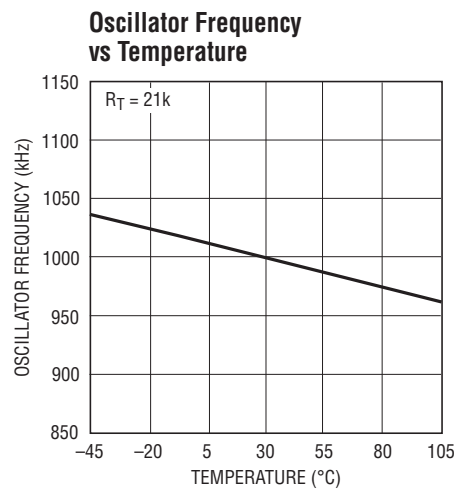

3476 G06

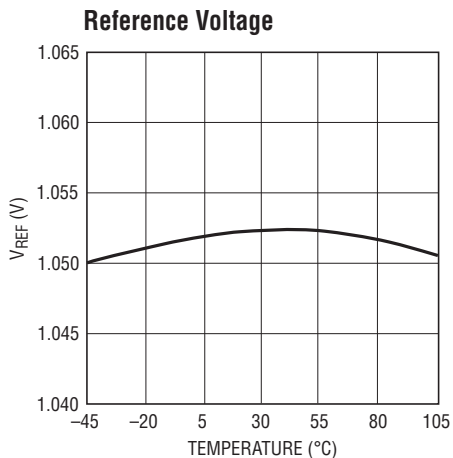

3476 G07

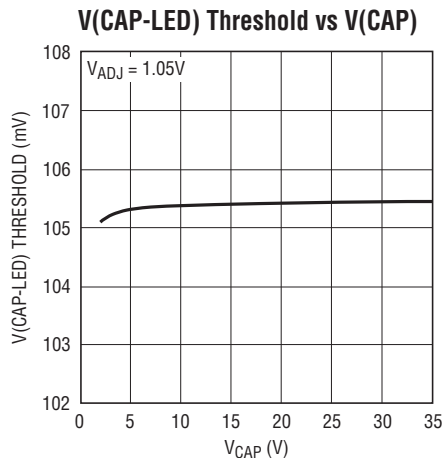

3476 G08

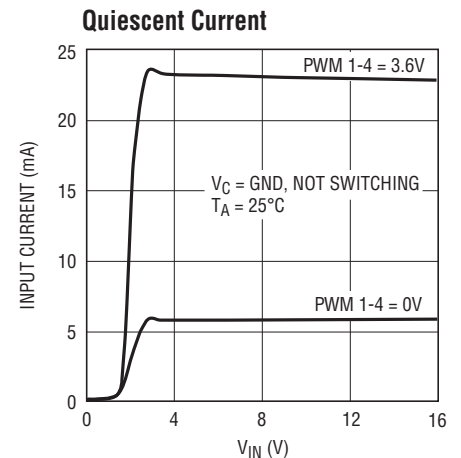

3476 G09

3476fa

PIN FUNCTIONS

VC1, VC4, VC3, VC2, (Pins 1, 12, 13, 38): Error Amplifier Compensation Pin. When PWM is low, V_C pin floats external compensation capacitor to save state for next cycle.

LED1, LED2, LED3, LED4, (Pins 2, 5, 8, 11): Non-Inverting Input of Current Sense Error Amplifier. Connect directly to LED current sense resistor terminal. Switcher will regulate this node to a voltage of $0.1 \cdot V_{ADJ}$ below the CAP node. Also connected to CAP node through external sense resistor and to anode of LED string. Do not allow this pin to float independently of corresponding CAP input pin. In applications where the LED current is low and the PV_{IN} changes widely, connect the output filter capacitor to LED n .

CAP1, CAP2, CAP3, CAP4, (Pins 3, 4, 9, 10): Inverting input of current sense error amplifier. Connect directly to other terminal of LED current sense resistor. Also connected to output filter capacitor and cathode of external Schottky rectifier. CAP greater than the overvoltage protect threshold will inhibit switching.

R_T (Pin 6): Oscillator Programming Pin. Place resistor connected to GND to program oscillator frequency.

REF: (Pin 7): Reference Output Pin. Connect to V_{ADJ} pin to get full-scale LED current. Connect to resistor dividers to program V_{ADJ} pins to values lower than 1.05V. Bypass to local GND with 0.1 μ F capacitor.

V_{ADJ4}, V_{ADJ3}, V_{ADJ2}, V_{ADJ1}, (Pins 14, 15, 36, 37): LED Current Adjustment Pin. Sets voltage across external sense resistor between CAP n and LED n . Connect directly to REF for full-scale threshold of 105mV, or use signal vales between GND and REF to modulate LED current. V_{ADJ} pin input range is 1.25V maximum.

PWM4, PWM3, PWM2, PWM1, (Pins 16, 17, 34, 35): Signal low turns off the channel—disables the main switch, reduces quiescent supply current to the channel, and causes the V_C pin for the channel to become high impedance.

SHDN (Pin 18): Shutdown Pin. Higher than 1.5V turns the device on.

NC (Pins 19, 20, 21, 30, 31, 32): Not Used. Connect to GND (Pin 39) for better heat dissipation.

SW4, SW3, SW2, SW1, (Pins 22, 23, 24, 25, 26, 27, 28, 29): Switch Pin. Connect to external inductor and anode of external Schottky rectifier. Minimize area of SW trace and use a GND plane to reduce EMI. Adjacent pins of same name are internally connected.

V_{IN} (Pin 33): Input Supply Pin. Must be locally bypassed.

GND (Pin 39): Signal and Power GND. Solder Exposed Pad directly to ground plane. The Exposed Pad metal of the package provides both electrical contact to ground and good thermal contact to the printed circuit board. It must be soldered to the circuit board for proper operation.

BLOCK DIAGRAM

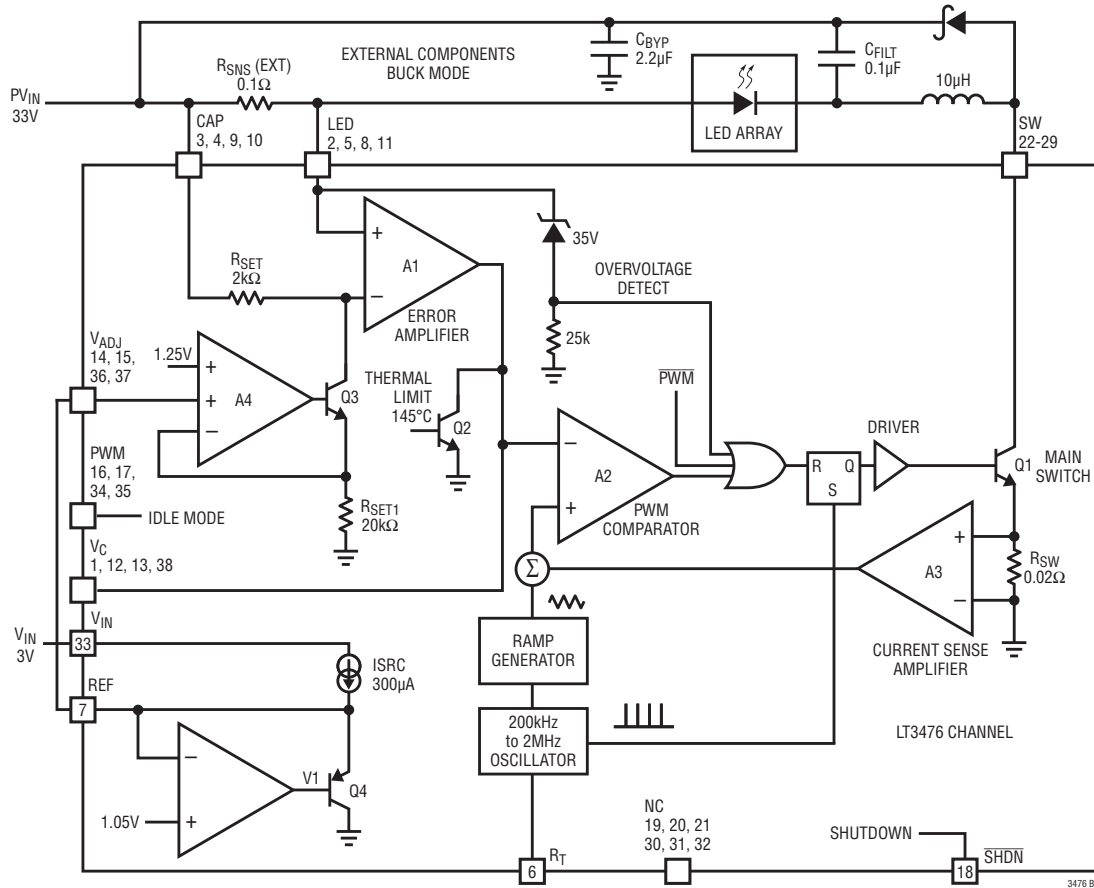

OPERATION

The LT3476 is a constant-frequency, current mode regulator with an internal power switch. Operation can be best understood by referring to the Block Diagram. At the start of each oscillator cycle, the SR latch is set, which turns on the Q1 power switch. A voltage proportional to the switch current is added to a stabilizing ramp and the resulting sum is fed into the positive terminal of the PWM comparator, A2. When this voltage exceeds the level at the negative input of A2, the SR latch is reset, turning off the power switch. The level at the negative input of A2 is set by the error amplifier A1, and is simply an amplified version of the difference between the voltage across the internal resistor R_{SET} and the voltage across the external current sense resistor R_{SNS} . In this manner, the error amplifier sets the correct peak switch current level to regulate the current through R_{SNS} . If the error amplifier's output increases, more current is delivered to the output; if it decreases, less current is delivered.

The current regulated in R_{SNS} can be adjusted by changing the voltage across R_{SET} using the V_{ADJ} input pin. The amplifier A4 regulates current in Q3 to produce a voltage across R_{SET} equal to V_{ADJ} . This current flowing through transistor Q3 also produces a voltage across R_{SET} one-tenth the magnitude of the V_{ADJ} input and level shifted to the CAP input. The voltage across R_{SET} is limited to 125mV (typ) by the separate 1.25V input on A4.

The average current regulated in R_{SNS} can also be adjusted for dimming using the PWM pin. When the PWM pin is low, switching is disabled and the error amplifier is turned off so that it does not drive the V_C pin. Also, all internal loads on the V_C pin are disabled so that the charge state of the V_C pin will be saved on the external compensation capacitor. This feature reduces transient recovery time because when the PWM input again transitions high, the demand current for the switch returns to the value just before PWM last transitioned low.

APPLICATIONS INFORMATION

Layout Hints

The high speed operation of the LT3476 demands careful attention to board layout. Several items are worthy of note. The exposed pad of the package is the only GND terminal of the IC and is also important to thermal management for the IC, so it is crucial to achieve a good electrical and thermal contact between the exposed pad and the ground plane of the board. Also, the Schottky rectifier and the capacitor between GND at the cathode of the Schottky are in the high frequency switching path where current flow is discontinuous. These elements should be placed so as to minimize the path between SW and the GND of the IC. To reduce EMI, it is important to minimize the area of the SW trace. Use a GND plane under SW to minimize interplane coupling to sensitive signals. To obtain good current regulation accuracy and eliminate sources of channel-to-channel coupling, the CAP and LED inputs of each channel of the LT3476 should be run as separate lines back to the terminals of the appropriate sense resistor. Since there is a small DC input bias current (~50 μ A) to the LED and CAP inputs, resistance in series with these inputs should be minimized, otherwise there will be an offset. Finally, the bypass capacitor on the V_{IN} supply to the LT3476 should be placed as close as possible to the V_{IN} terminal of the device.

Open-Circuit Protection/Overvoltage Lockout

The LT3476 has independent internal overvoltage/open-circuit protection (OVP) for all four converters, sensed through their respective CAP inputs. The purpose of the OVP feature is to protect the main switch of the device from damage. In the boost configuration, if the LEDs are disconnected from the circuit or fail open, the converter output voltage at CAP is clamped at the OVP voltage of 35V (typ). Figure 1 shows the transient response of the step-up converter application with LED1 disconnected. With LED1 disconnected, the converter switches at current limit as the output ramps up to OVP. Upon reaching the OVP clamp voltage, the converter will switch with a reduced current limit to regulate the converter output voltage at the OVP clamp. In the buck mode application shown in the Block Diagram, should the external supply for CAP exceed the OVP clamp, then switching will be inhibited for the converter. In order for the overvoltage

protection feature to adequately protect the switch, it is important that the CAP input sample a voltage at or near the highest voltage reached by the SW node. As a result, this OVP function will not provide adequate protection from open load events in isolated power configurations such as the 1:1 flyback, since input and output voltage magnitudes must be summed to obtain the voltage seen by the switch.

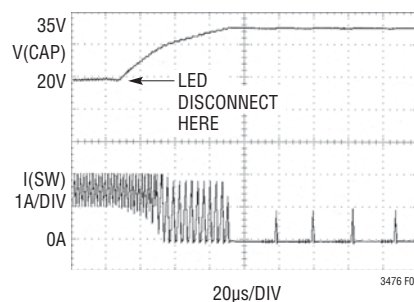

Figure 1. LED Disconnect Transient

Setting the Switching Frequency

The switching frequency of the LT3476 is set by an external resistor connected between the R_T pin and GND. Do not leave this pin open. Also, do not load this pin with a capacitor. A resistor must always be connected for proper operation. See Table 1 below or see the Oscillator Frequency vs R_T graph in the Typical Performance Characteristics for resistor values and corresponding switching frequencies.

Table 1. Switching Frequency vs R_T

SWITCHING FREQUENCY (kHz)	R_T (k Ω)
200	140
400	61.9
1000	21
1200	16.2
2000	8.25

In general, a lower switching frequency should be used where either very high or very low switch duty cycle operation is required, or higher efficiency is desired. Selection of a higher switching frequency will allow use of smaller value external components and yield a smaller solution size and profile. Also for high frequency PWM dimming, a higher switching frequency (shorter switching period)

APPLICATIONS INFORMATION

will give better dimming control since for turning on the switch, the state of the PWM pin is sampled only during a narrow time slot at the beginning of each switch period.

Inductor Selection

The inductors used with the LT3476 should have a saturation current rating of 2.5A or greater. For best loop stability results, the inductor value selected should provide a ripple current of 350mA or more. For buck (step-down) or boost (step-up) configurations, and using a 21kΩ resistor on R_T ($T_{SW} \sim 1\mu s$), inductor values from 4.7μH to 10μH are recommended for most applications. In the buck mode, the inductor value can be estimated using the formula:

$$L(\mu H) = \frac{D_{BUCK} \cdot T_{SW}(\mu S) \cdot (V_{CAP} - V_{LED})}{\Delta I}$$

$$D_{BUCK} = \frac{V_{LED}}{V_{CAP}}$$

V_{LED} is the voltage across the LED string and V_{CAP} is the input voltage to the converter. In the boost mode, the inductor value can be estimated using the formula:

$$L(\mu H) = \frac{D_{BOOST} \cdot T_{SW}(\mu S) \cdot V_{IN}}{\Delta I}$$

$$D_{BOOST} = \frac{V_{CAP} - V_{IN}}{V_{CAP}}$$

V_{IN} is the input voltage and V_{CAP} is the voltage across the LED string. Table 2 below provides some suggested components and vendors.

Table 2. Inductors

PART NUMBER	VALUE (μH)	IRMS (A)	DCR (Ω)	HEIGHT (mm)
Sumida				
CDRH6D38-100	10	2.0	0.028	4.0
CDRH5D28-5R3	5.3	1.90	0.028	3.0
CDRH73-100	10	1.68	0.072	3.4
Toko				
D63CB	10	1.49	0.042	3.5
D63CB	4.7	2.08	0.026	3.5
Cooper-ET				
SD25-4R7	4.7	1.80	0.047	2.5

Input Capacitor Selection

For proper operation, it is necessary to place a bypass capacitor to GND close to the V_{IN} pin of the LT3476. A 1μF, or greater, capacitor with low ESR should be used. A ceramic capacitor is usually the best choice.

In the buck configuration, the capacitor at the input to the power converter has large pulsed currents due to the current returned through the Schottky diode when the switch is off. For best reliability, this capacitor should have low ESR and ESL and meet the ripple current requirement,

$$I_{RMS} = I_{SW} \cdot \sqrt{((1-D) \cdot D)}$$

where D is the switch duty cycle. A 2.2μF ceramic type capacitor placed close to the Schottky and the ground plane is usually sufficient for each channel.

Output Capacitor Selection

The selection of output filter capacitor depends on the load and the converter configuration, i.e., step-up or step-down. For LED applications, the equivalent resistance of the LED is typically low, and the output filter capacitor should be sized to attenuate the current ripple from the inductor to 35mA or less. The following equation is useful to estimate the required capacitor value:

$$C_{FILT} = 2 \cdot \frac{T_{SW}}{R_{LED}}$$

A typical filter capacitor value for $R_{LED} = 5\Omega$ and $T_{SW} = 1\mu s$ is 0.47μF. For loop stability, consider the output pole is at the frequency where closed loop gain should be unity, so the dominant pole for loop compensation will be established by the capacitor at the V_C input.

For the LED boost applications, to achieve the same LED ripple current the required filter capacitor value is about five times larger than the value calculated above due to the pulsed nature of the source current. A 2.2μF ceramic type capacitor placed close to the Schottky and the ground plane of the I_C is usually sufficient for each channel.

As the output capacitor is subject to high ripple current, ceramic capacitors are recommended due to their low ESR and ESL at high frequency.

APPLICATIONS INFORMATION

Ceramic type capacitors using X7R dielectric are best for temperature and DC bias stability of the capacitor value. All ceramic capacitors exhibit loss of capacitance value with increasing DC voltage bias, so it may be necessary to choose a higher value capacitor or larger case size to get the required capacitance at the operating voltage. Always check that the voltage rating of the capacitor is sufficient. Table 3 shows some recommended capacitor vendors.

Table 3. Low-ESR Surface Mount Capacitors

VENDOR	TYPE	SERIES
Taiyo-Yuden	Ceramic	X5R, X7R
AVX	Ceramic	X5R, X7R
Murata	Ceramic	X5R, X7R

Compensation Design

The LT3476 uses an internal transconductance error amplifier whose V_C output compensates the control loop. The external inductor, output capacitor, and compensation resistor and capacitor determine the loop stability. The inductor and output capacitor are chosen based on performance, size and cost. The compensation resistor and capacitor at V_C are selected to optimize control loop stability. The component values shown in the typical applications circuits yield stable operation over the given range of input-to-output voltages and load currents. For most buck applications, a small filter capacitor (1 μ F or less) across the load is desirable. In this case, a 10nF compensation capacitor at V_C is usually quite adequate. A compensation resistor of 5k Ω placed between the V_C output and the compensation capacitor minimizes channel-to-channel interaction by reducing transient recovery time. The boost configuration will have a larger output capacitor, 2.2 μ F to 10 μ F.

The following circuit techniques involving the compensation pin may be helpful where there is a large variation in programmed LED current, or a large input supply range is expected. At low duty cycles (T_{ON} less than 350ns) and low average inductor current (less than 500mA), the LT3476 may start to skip switching pulses to maintain output regulation. Pulse-skipping mode is usually less desirable because it leads to increased ripple current in the LED. To improve the onset of pulse-skipping behavior, place a capacitor between the SW node and the compensation

capacitor that is 1:1000 the value of the compensation capacitor. In the buck configuration, an additional technique is available. The filter capacitor between the CAP node and the LED bottom (see the Typical Application on the first page) can be moved to between the LED top and the LED bottom. This circuit change places the inductor ripple current through the sense resistor, which improves pulse-skipping behavior. There is usually less than 1% impact to the current regulation point.

Diode Selection

The Schottky rectifier conducts current during the interval when the switch is turned off. Select a diode with V_R rated for the maximum SW voltage. For boost circuits that may use the output disconnect feature, the diode should be rated for at least 40V. It is not necessary that the forward current rating of the diode equal the switch current limit. The average current I_F through the diode is a function of the switch duty cycle, so select a diode with forward current rating of $I_F = 1.5A \cdot (1-D)$. If using the PWM feature for dimming, it may also be important to consider diode leakage from the output (especially at hot) during the PWM low interval. Table 4 has some recommended component vendors.

Table 4. Schottky Diodes

PART NUMBER	V_R (V)	I_{AVE} (A)	V_F AT 1A (mV)
On Semiconductor			
MBRM140	40	1	550
Diodes Inc.			
DFLS140L	40	1	550
B140 HB	40	1	530
Philips Semiconductor			
PMEG4010EJ	40	1	540

APPLICATIONS INFORMATION

Programming the LED Current

The LED Current is programmed using an external sense resistor in series with the load. This method allows flexibility in driving the load (i.e., sensing one of several parallel strings) while maintaining good accuracy. The V_{ADJ} input sets the voltage regulation threshold across the external sense resistor between 10mV and 120mV. A 1.05V reference output (REF) is provided to drive the V_{ADJ} pins either through a resistor divider, or connected directly to REF to give the full-scale threshold of 105mV. A DAC may also be used to drive the V_{ADJ} pins. The V_{ADJ} pins should not be left open. If the V_{ADJ} input is connected to a voltage higher than 1.25V, the default regulation threshold across CAP and LED is 125mV (typ). The V_{ADJ} pin can also be used in conjunction with a PTC thermistor to provide overtemperature protection for the LED load as shown in Figure 2.

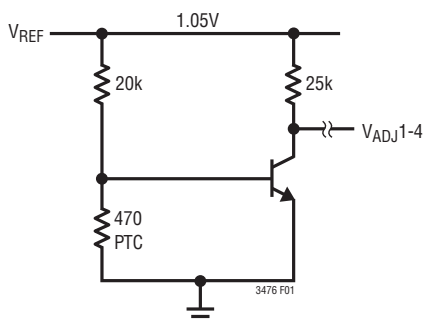

Figure 2. Overtemperature Protect Circuit

Dimming Control

There are two methods to control the current source for dimming using the LT3476. The first method, popular with LED applications, uses the PWM pin to modulate the current source between zero and full current to achieve a precisely programmed average current. To make this method of current control more accurate, during the quiescent phase the switch demand current is stored on the V_C node. This feature minimizes recovery time when the PWM signal goes high. The minimum PWM on- or off-time will depend on the choice of operating frequency through the R_T input pin. For best current accuracy, the minimum PWM low or high time should be at least ten switching cycles. This guideline has two reasons: first to allow the output to reach steady state before shutting off, and second because the oscillator is not synchronized to the PWM signal and there may be as much as one switching cycle delay from PWM going high to the start of switching. This delay, however, does not apply to the negative transition of the PWM signal. The minimum PWM low/high time can be reduced to five switching cycles if a disconnect switch is used in the LED current path.

The second method of dimming control uses the V_{ADJ} pin to linearly adjust the current sense threshold during the PWM high state. The LED current programming feature augments the PWM dimming control, possibly increasing total dimming range by a factor of ten.

TYPICAL APPLICATION

5V to 25V Step-Up/Step-Down Driver for 2 Series 350mA LEDs

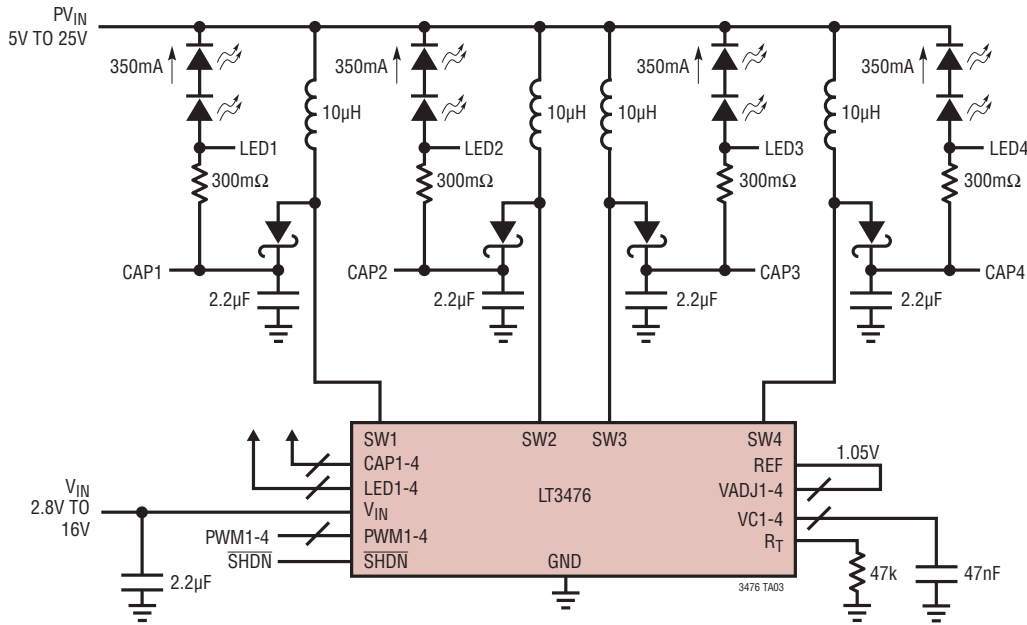

PACKAGE DESCRIPTION

UHF Package
38-Lead Plastic QFN (5mm × 7mm)
 (Reference LTC DWG # 05-08-1701)

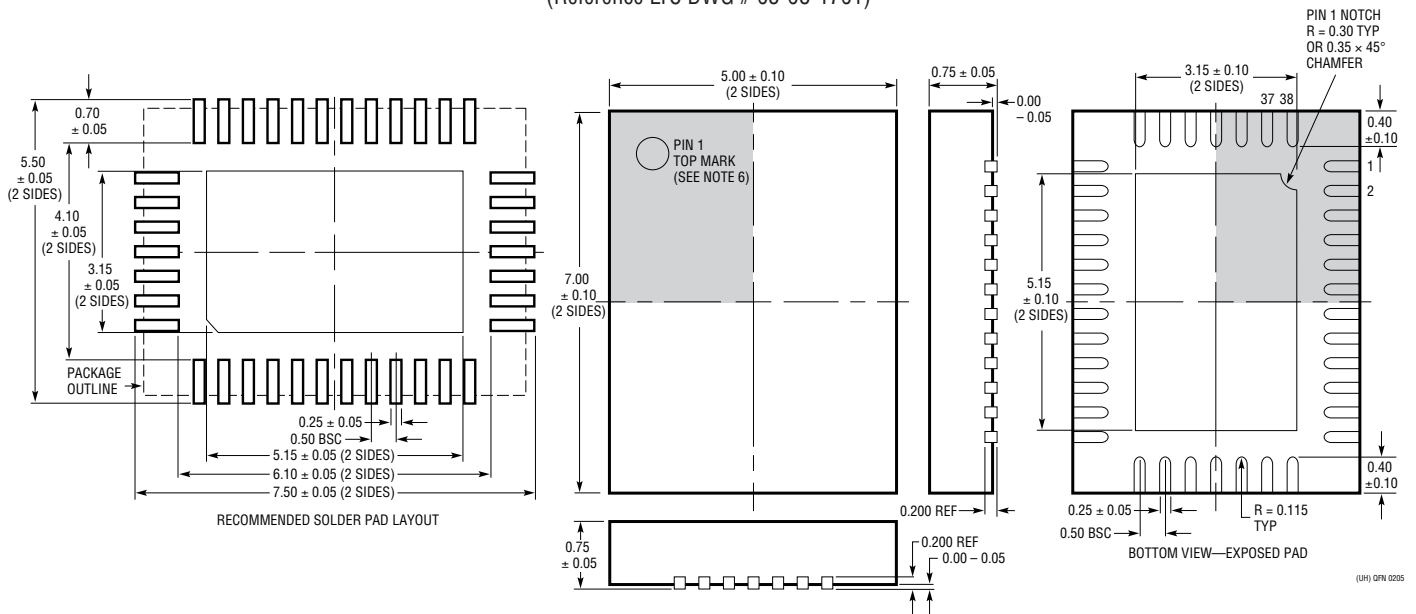

- NOTE:
1. DRAWING CONFORMS TO JEDEC PACKAGE OUTLINE M0-220 VARIATION WHKD
 2. DRAWING NOT TO SCALE
 3. ALL DIMENSIONS ARE IN MILLIMETERS
 4. DIMENSIONS OF EXPOSED PAD ON BOTTOM OF PACKAGE DO NOT INCLUDE MOLD FLASH. MOLD FLASH, IF PRESENT, SHALL NOT EXCEED 0.20mm ON ANY SIDE
 5. EXPOSED PAD SHALL BE SOLDER PLATED
 6. SHADED AREA IS ONLY A REFERENCE FOR PIN 1 LOCATION ON THE TOP AND BOTTOM OF PACKAGE

TYPICAL APPLICATION

Quad Boost 100mA × 8LED Driver

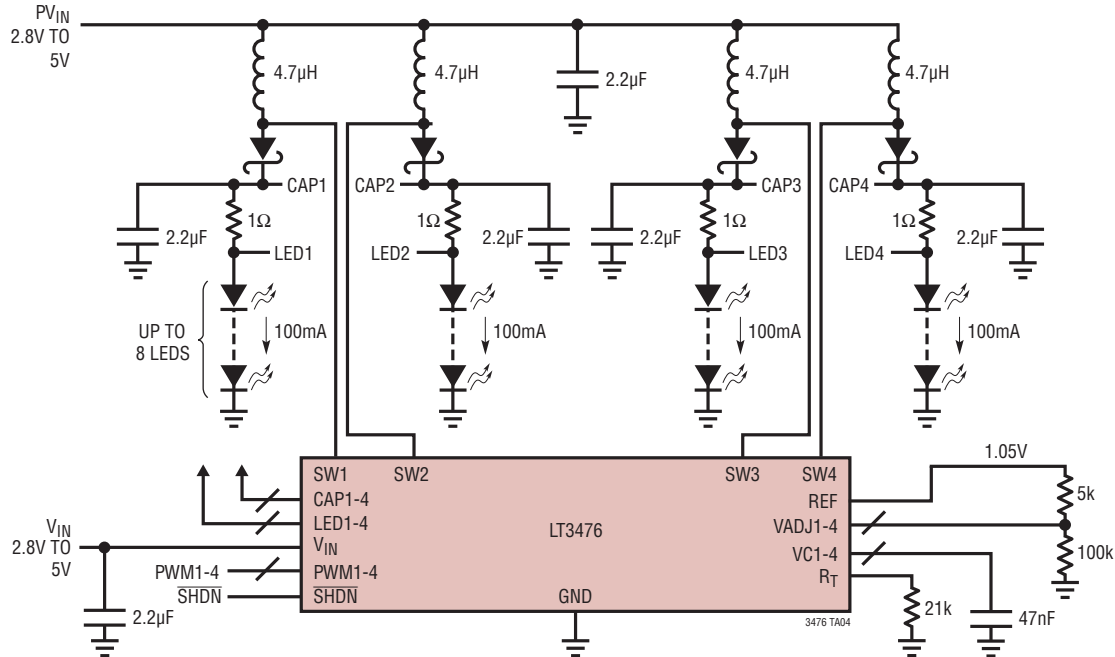

RELATED PARTS

PART NUMBER	DESCRIPTION	COMMENTS
LT1618	1.5A, Constant-Current, 1.4MHz, Boost Converter	$V_{IN(MIN)} = 5V$, $V_{IN(MAX)} = 18V$, $V_{OUT(MAX)} = 36V$, Dimming = Analog/PWM, $I_{SD} < 1\mu A$, MS10 Package
LTC3454	1A Synchronous Buck-Boost LED Driver	$V_{IN(MIN)} = 2.7V$, $V_{IN(MAX)} = 5.5V$, $V_{OUT(MAX)} = 5.5V$, Dimming = 4-Levels of Adj, $I_{SD} < 1\mu A$, DFN-10 Package
LTC3474	1A (I_{LED}), 36V, 2MHz, Step-Down LED Driver	$V_{IN(MIN)} = 4V$, $V_{IN(MAX)} = 36V$, $V_{OUT(MAX)} = 13.5V$, 400:1 True Color PWM, $I_{SD} < 1\mu A$, TSSOP-16E Package
LT3475	Dual 1.5A (I_{LED}), 36V, 2MHz, Step-Down LED Driver	$V_{IN(MIN)} = 4.0V$, $V_{IN(MAX)} = 36V$, $V_{OUT(MAX)} = 13.5V$, Dimming = 3000:1 True Color PWM, $I_{SD} < 1\mu A$, TSSOP-20E Package
LT3477	3A, 42V, 3.5MHz Boost, Buck-Boost, Buck LED Driver	$V_{IN(MIN)} = 2.5V$, $V_{IN(MAX)} = 25V$, $V_{OUT(MAX)} = 40V$, Dimming = Analog/PWM, $I_{SD} < 1\mu A$, QFN and TSSOP-20E Packages
LT3479	3A, Full-Featured DC/DC Converter with Soft-Start and Inrush Current Protection	$V_{IN(MIN)} = 2.5V$, $V_{IN(MAX)} = 24V$, $V_{OUT(MAX)} = 40V$, Dimming = Analog/PWM, $I_{SD} < 1\mu A$, DFN and TSSOP Packages