

LT3042EDD

20V, 200mA, Ultralow Noise Ultrahigh PSRR RF LDO Regulator

DESCRIPTION

DC2246B is a linear regulator featuring the **LT[®]3042EDD**, which is a 200mA, ultralow noise, and ultrahigh power supply rejection ratio (PSRR) RF low dropout (LDO) regulator with programmable current limit.

DC2246B operates over an input voltage range of 3.8V to 20V. The LT3042 has a maximum output current of 200mA. It features ultralow noise ($0.8\mu\text{V}_{\text{RMS}}$ from 10Hz to 100kHz) and very high PSRR (79dB at 1MHz). The power good feedback (PGFB) pin voltage is programmable for power good threshold. A current limit function is provided. Current monitoring is also achievable by sensing the voltage on the ILIM pin.

Built-in protection includes reverse battery protection, reverse current protection, internal current limit with foldback and thermal limit with hysteresis.

The LT3042 data sheet gives a complete description of the device, operation and applications information. The data sheet must be read in conjunction with this Demo Manual for demonstration circuit DC2246B. The LT3042EDD is assembled in a 10-lead (3mm × 3mm) plastic DFN package with an exposed pad on the bottom-side of the IC. **Proper board layout is essential for maximum thermal performance.**

Design files for this circuit board are available at <http://www.linear.com/demo/DC2246B>

LT, LT, LTC, LTM, Linear Technology and the Linear logo are registered trademarks of Linear Technology Corporation. All other trademarks are the property of their respective owners.

PERFORMANCE SUMMARY

Specifications are at $T_A = 25^\circ\text{C}$

PARAMETER	CONDITIONS	MIN	TYP	MAX	UNITS
Input Voltage Range (V_{IN})	$V_{\text{OUT}} = 3.3\text{V}$	3.8		20	VDC
Shutdown Input Current (I_{IN})	JP1 = OFF, $V_{\text{IN}} = 6\text{V}$		0.1		μA
Output Voltage (V_{OUT})	$V_{\text{IN}} = 5\text{V}$, $I_{\text{OUT}} = 200\text{mA}$	3.2	3.3	3.4	VDC
Output Current Range (I_{OUT})	$V_{\text{IN}} = 3.8\text{V} \sim 19.7\text{V}$, $V_{\text{OUT}} = 3.3\text{V}$	0		200	mA
Output Current Range (I_{OUT})	$V_{\text{IN}} = 3.8\text{V} \sim 20\text{V}$, $V_{\text{OUT}} = 3.3\text{V}$	0		195*	mA

* Please refer to the Current Limit vs Input-to-Output Differential in the LT3042 data sheet.

BOARD PHOTO

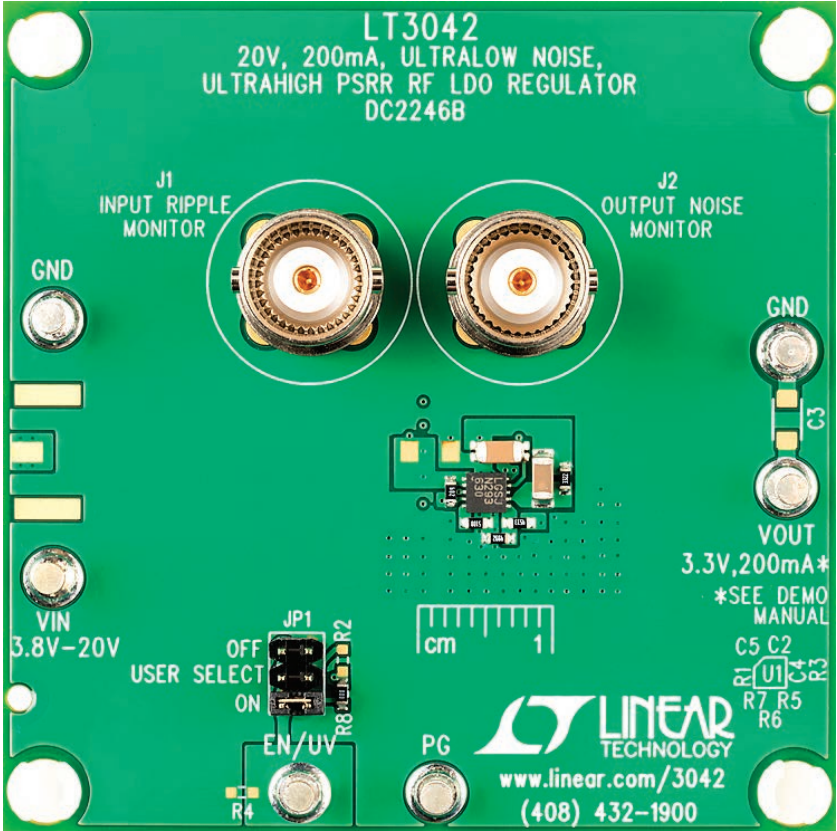

QUICK START PROCEDURE

The DC2246B is easy to set up to evaluate the performance of the LT3042EDD. Refer to Figure 1 for proper measurement equipment setup and follow the procedure below:

1. Connect Load between the VOUT and GND terminals.
2. With power off, connect the input power supply to the VIN and GND terminals.
3. Make sure the shunt of JP1 is at ON option.
4. Turn the input power supply on and make sure the

voltage is between 3.8V and 20V.

5. Refer to Application Notes AN70 and AN159 for measuring the output noise and PSRR.
6. R2 and R4 can define an accurate undervoltage lockout (UVLO) threshold when the shunt of JP1 is at USER SELECT option.

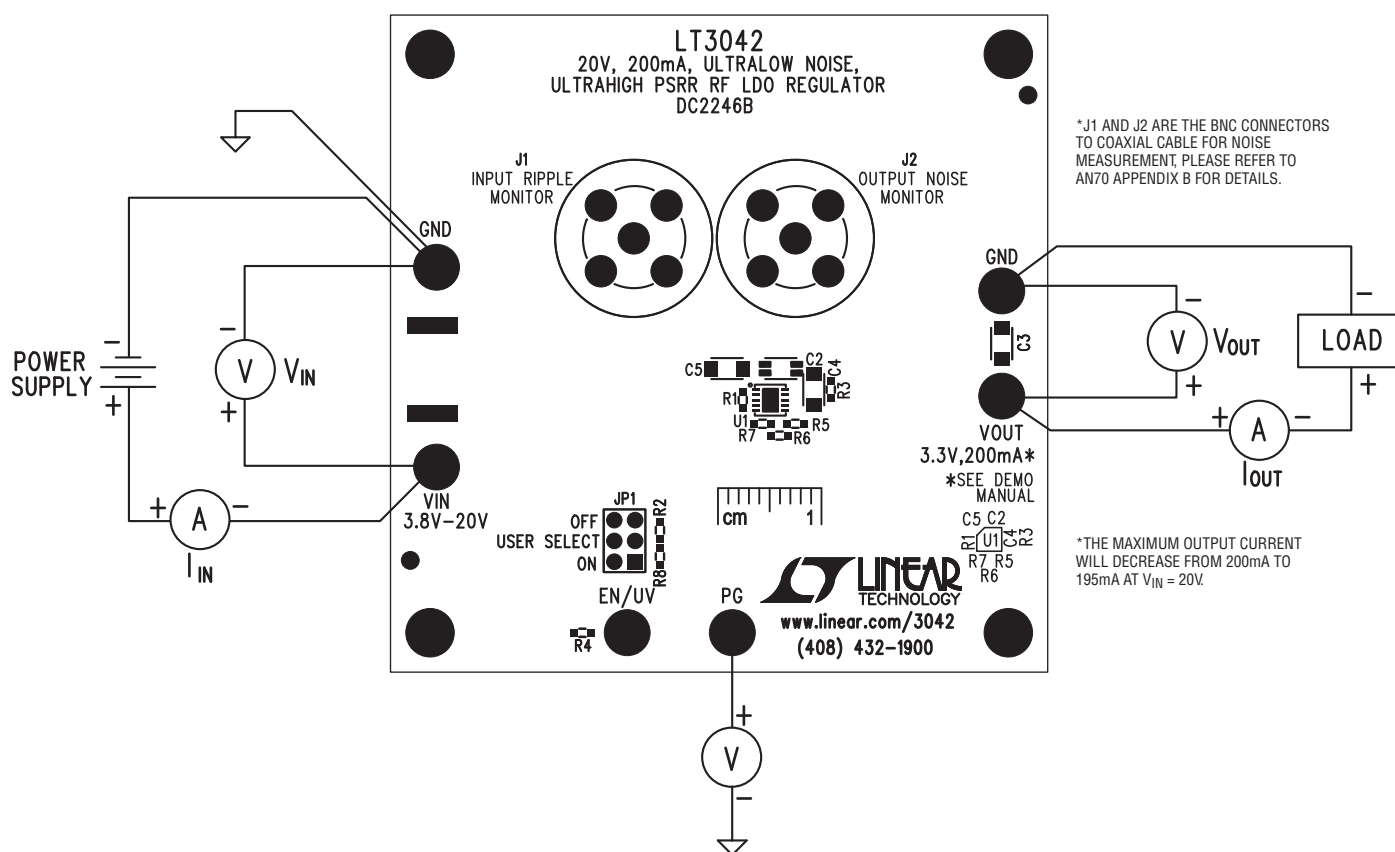

Figure 1. Test Procedure Setup Drawing for DC2246B

PCB LAYOUT

Best PSRR Performance: PCB Layout for Input Trace

For applications utilizing the LT3042 for post-regulating switching converters, placing a capacitor directly at the LT3042 input results in AC current (at the switching frequency) to flow near the LT3042. Without careful attention to PCB layout, this relatively high frequency switching current generates an Electromagnetic Field (EMF) that couples to the LT3042 output, thereby degrading its effective PSRR. While highly dependent on the PCB, the switching pre-regulator, the input capacitor size, among other factors, the PSRR degradation can easily be 30dB at 1MHz. This degradation is present even if the LT3042 is de-soldered from the board, because it effectively degrades the PSRR of the PC board itself. While negligible for conventional low PSRR LDOs, LT3042's ultrahigh PSRR requires careful

attention to higher order parasitics in order to realize the full performance offered by the regulator.

The LT3042 demo board alleviates this degradation in PSRR by using a specialized layout technique. On layer 3, the input trace (VIN) is highlighted in red, with the return path (GND) highlighted on the bottom layer together with input capacitor C1. When an AC voltage is applied to the input of the board, AC current flows on this path, thus generating EMF. This EMF couples to output capacitor C2 and related traces, making the PSRR appear worse than it actually is. **With the input trace directly above the return path, the EMFs are in opposite directions, and consequently cancels each other out. Making sure these traces exactly overlap each other maximizes the cancellation effect and thus provides the maximum PSRR offered by the regulator.**

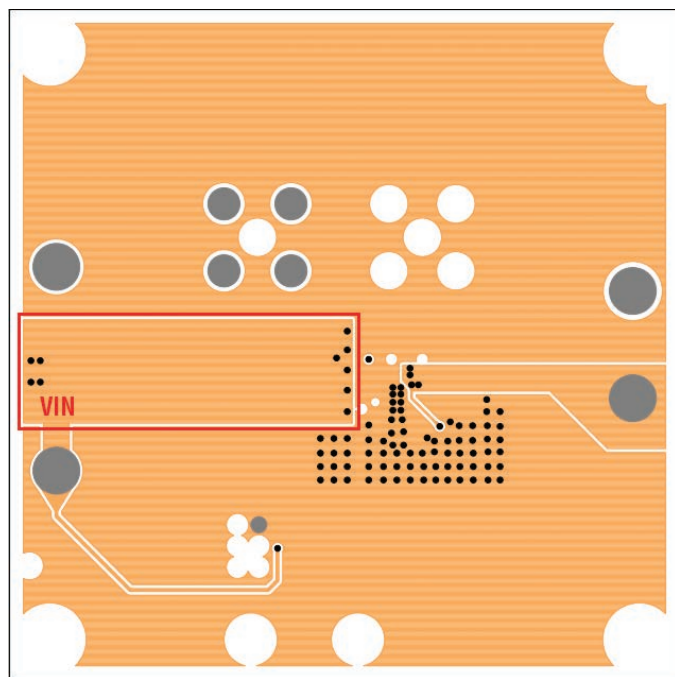

Figure 2. Layer 3 of the DC2246B

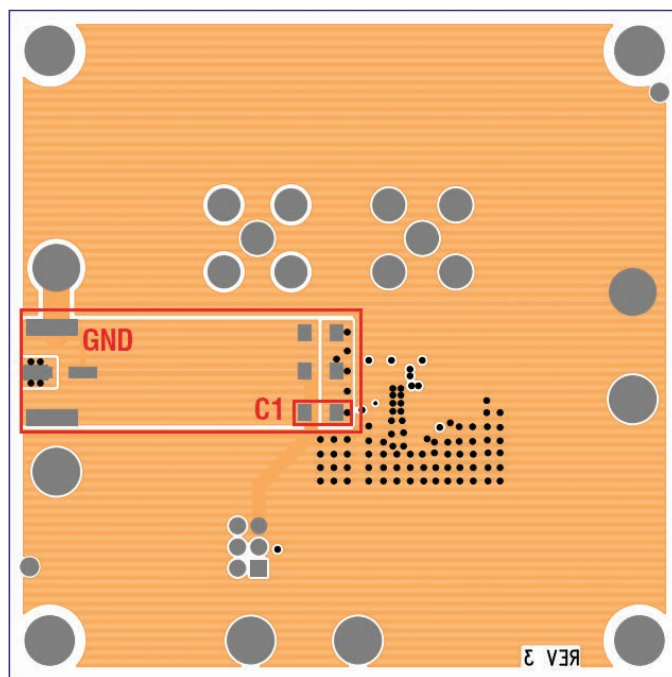

Figure 3. Bottom Layer of the DC2246B

PCB LAYOUT

Best AC Performance: PCB Layout for Output Capacitor C2

For ultrahigh PSRR performance, the LT3042 bandwidth is made quite high (~1MHz), making it close to the output capacitor's self-resonance frequency (~2MHz). Therefore, it is very important to avoid adding extra impedance (ESL and ESR) outside the feedback loop. To that end, minimize the effects of PCB trace and solder inductance by Kelvin connecting OUTS and SET pin capacitor (C4) GND directly to output capacitor (C2) terminals using split capacitor techniques. Pad 4 connects to the OUTS pin and Pad 1 connects to the GND side of the SET pin capacitor. With only small AC current flowing through these connections, the impact of solder joint/PCB trace inductance on stability is eliminated. While the LT3042 is robust enough not to

oscillate if the recommended layout is not followed, phase/gain margin and stability will degrade.

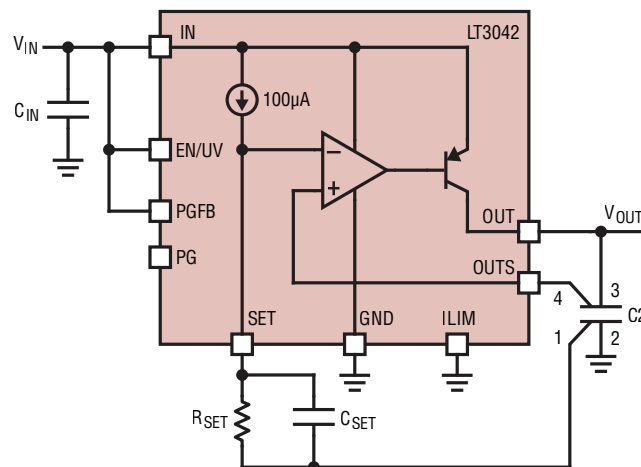

Figure 4. C2 and C_{SET} Connections for Best Performance

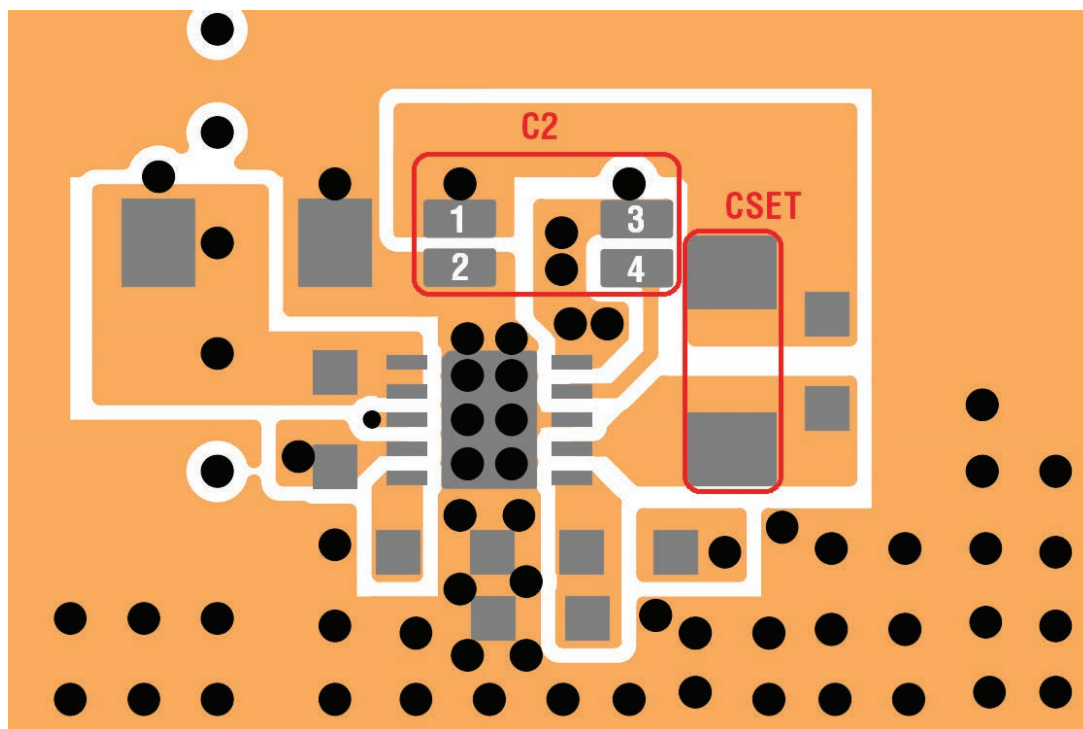

Figure 5. Split Pads for C2 on Top Layer of DC2246B

DEMO MANUAL DC2246B

PARTS LIST

ITEM	QTY	REFERENCE	PART DESCRIPTION	MANUFACTURER/PART NUMBER
Required Circuit Components				
1	1	C1N	CAP., ALUM, 22 μ F, 35V, 5X5.4MM	SUN ELEC., 32CE22BSS
2	3	C1, C2, C4	CAP., X7R, 4.7 μ F, 25V, 10%, 1206	MURATA, GRM31CR71E475KA88L
3	1	R1	RES., CHIP, 200k, 1/16W, 5% 0603	VISHAY, CRCW0603200KJNEA
4	1	R3	RES., CHIP, 33.2k, 1/8W, 1% 0603	VISHAY, CRCW060333K2FKEA
5	1	R5	RES., CHIP, 453k, 1/8W, 1% 0603	VISHAY, CRCW0603453KFKFA
6	1	R6	RES., CHIP, 49.9k, 1/8W, 1% 0603	VISHAY, CRCW060349K9FKFA
7	1	R7	RES., CHIP, 510 Ω , 1/10W, 1% 0603	VISHAY, CRCW0603510RFKEA
8	1	U1	IC, LT3042EDD DFN 3X3MM	LINEAR TECH., LT3042EDD#PBF
Optional Electronic Components				
1	1	R8	RES., CHIP, 0 Ω , 1/16W, 5% 0603	VISHAY, CRCW06030000Z0EA
2	0	R2, R4 (OPT)	RES., OPT, 0603	
3	0	C3, C5(OPT)	CAP., OPT, 1206	
Hardware: For Demo Board Only				
1	6	E1-E6	TESTPOINT, TURRET, 0.094" PBF	MILL-MAX, 2501-2-00-80-00-00-07-0
2	1	JP1	HEADER 3 PIN 0.079" DOUBLE ROW	WURTH ELEKTRONIK, 62000621121
3	1	XJP1	SHUNT, 0.079" CENTER	WURTH ELEKTRONIK, 60800213421
4	2	J1, J2	CONN, BNC, 5 PINS	CONNEX, 112404
5	4	MH1-MH4	STAND-OFF, NYLON 6.4MM	WURTH ELEKTRONIK, 702931000

SCHEMATIC DIAGRAM

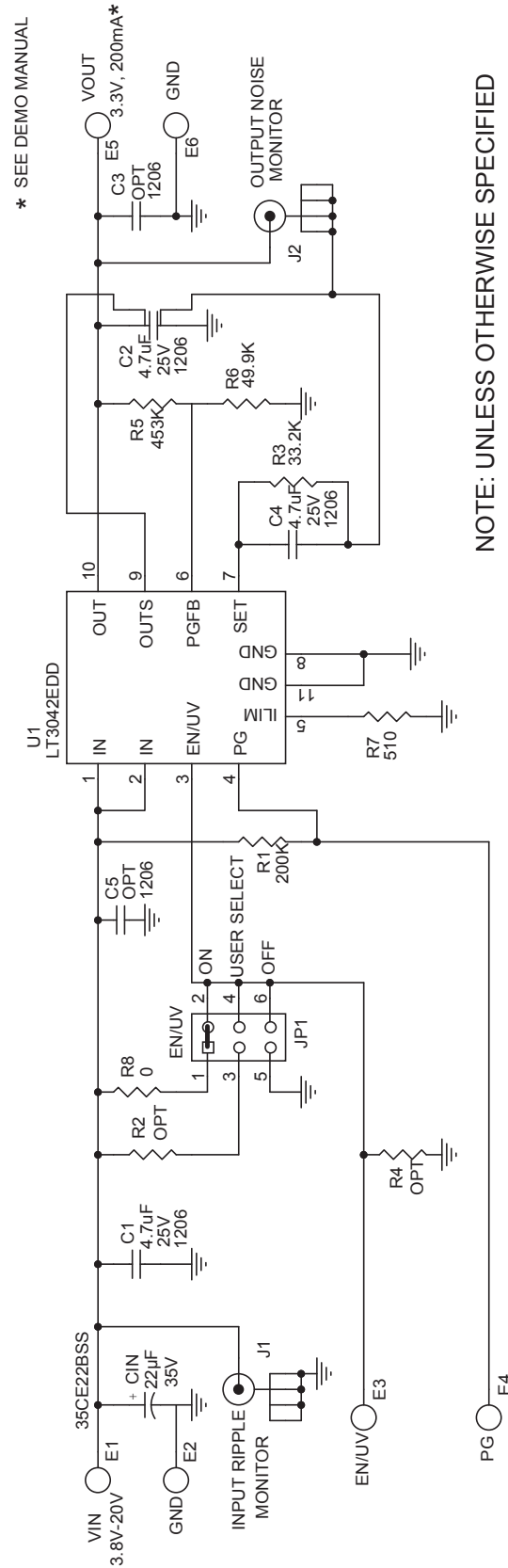

* SEE DEMO MANUAL

NOTE: UNLESS OTHERWISE SPECIFIED

1. ALL RESISTORS ARE 0603.

DEMO MANUAL DC2246B

DEMONSTRATION BOARD IMPORTANT NOTICE

Linear Technology Corporation (LTC) provides the enclosed product(s) under the following **AS IS** conditions:

This demonstration board (DEMO BOARD) kit being sold or provided by Linear Technology is intended for use for **ENGINEERING DEVELOPMENT OR EVALUATION PURPOSES ONLY** and is not provided by LTC for commercial use. As such, the DEMO BOARD herein may not be complete in terms of required design-, marketing-, and/or manufacturing-related protective considerations, including but not limited to product safety measures typically found in finished commercial goods. As a prototype, this product does not fall within the scope of the European Union directive on electromagnetic compatibility and therefore may or may not meet the technical requirements of the directive, or other regulations.

If this evaluation kit does not meet the specifications recited in the DEMO BOARD manual the kit may be returned within 30 days from the date of delivery for a full refund. **THE FOREGOING WARRANTY IS THE EXCLUSIVE WARRANTY MADE BY THE SELLER TO BUYER AND IS IN LIEU OF ALL OTHER WARRANTIES, EXPRESSED, IMPLIED, OR STATUTORY, INCLUDING ANY WARRANTY OF MERCHANTABILITY OR FITNESS FOR ANY PARTICULAR PURPOSE. EXCEPT TO THE EXTENT OF THIS INDEMNITY, NEITHER PARTY SHALL BE LIABLE TO THE OTHER FOR ANY INDIRECT, SPECIAL, INCIDENTAL, OR CONSEQUENTIAL DAMAGES.**

The user assumes all responsibility and liability for proper and safe handling of the goods. Further, the user releases LTC from all claims arising from the handling or use of the goods. Due to the open construction of the product, it is the user's responsibility to take any and all appropriate precautions with regard to electrostatic discharge. Also be aware that the products herein may not be regulatory compliant or agency certified (FCC, UL, CE, etc.).

No License is granted under any patent right or other intellectual property whatsoever. **LTC assumes no liability for applications assistance, customer product design, software performance, or infringement of patents or any other intellectual property rights of any kind.**

LTC currently services a variety of customers for products around the world, and therefore this transaction **is not exclusive**.

Please read the DEMO BOARD manual prior to handling the product. Persons handling this product must have electronics training and observe good laboratory practice standards. **Common sense is encouraged.**

This notice contains important safety information about temperatures and voltages. For further safety concerns, please contact a LTC application engineer.

Mailing Address:

Linear Technology
1630 McCarthy Blvd.
Milpitas, CA 95035

Copyright © 2004, Linear Technology Corporation