

1.4MHz, Single Cell DC/DC Converter in 5-Lead SOT-23

FEATURES

- Uses Tiny Capacitors and Inductor
- Internally Compensated
- Fixed Frequency 1.4MHz Operation
- Operates with V_{IN} as Low as 1.1V
- 3V at 30mA from a Single Cell
- 5V at 200mA from 3.3V Input
- 15V at 60mA from Four Alkaline Cells
- High Output Voltage: Up to 34V
- Low Shutdown Current: $<1\mu A$
- Low V_{CESAT} Switch: 300mV at 300mA
- Tiny 5-Lead SOT-23 Package

APPLICATIONS

- Digital Cameras
- Pagers
- Cordless Phones
- Battery Backup
- LCD Bias
- Medical Diagnostic Equipment
- Local 5V or 12V Supply
- External Modems
- PC Cards

DESCRIPTION

The LT[®]1613 is the industry's first 5-lead SOT-23 current mode DC/DC converter. Intended for small, low power applications, it operates from an input voltage as low as 1.1V and switches at 1.4MHz, allowing the use of tiny, low cost capacitors and inductors 2mm or less in height. Its small size and high switching frequency enables the complete DC/DC converter function to take up less than 0.2 square inches of PC board area. Multiple output power supplies can now use a separate regulator for each output voltage, replacing cumbersome quasi-regulated approaches using a single regulator and a custom transformer.

A constant frequency, internally compensated current mode PWM architecture results in low, predictable output noise that is easy to filter. The high voltage switch on the LT1613 is rated at 36V, making the device ideal for boost converters up to 34V as well as for Single-Ended Primary Inductance Converter (SEPIC) and flyback designs. The device can generate 5V at up to 200mA from a 3.3V supply or 5V at 175mA from four alkaline cells in a SEPIC design.

The LT1613 is available in the 5-lead SOT-23 package.

 LTC and LT are registered trademarks of Linear Technology Corporation.

TYPICAL APPLICATION

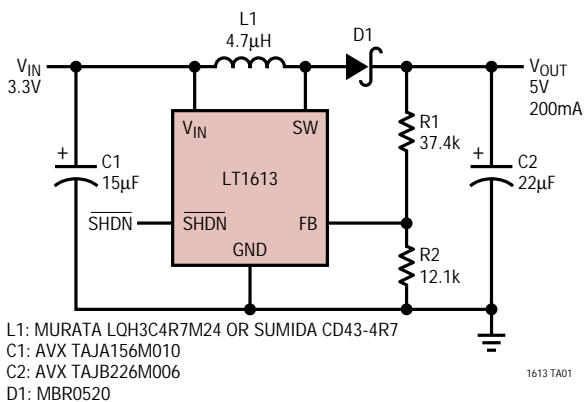
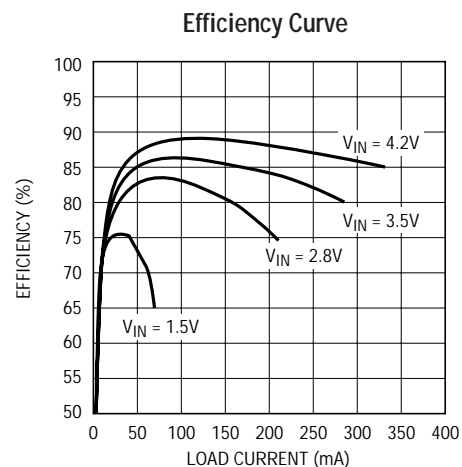

Figure 1. 3.3V to 5V 200mA DC/DC Converter



1613 TA01a

ABSOLUTE MAXIMUM RATINGS

(Note 1)

V_{IN} Voltage	10V
SW Voltage	-0.4V to 36V
FB Voltage	$V_{IN} + 0.3V$
Current into FB Pin	$\pm 1mA$
SHDN Voltage	10V
Maximum Junction Temperature	125°C
Operating Temperature Range	
Commercial	0°C to 70°C
Extended Commercial (Note 2)	-40°C to 85°C
Storage Temperature Range	-65°C to 150°C
Lead Temperature (Soldering, 10 sec)	300°C

PACKAGE/ORDER INFORMATION

	ORDER PART NUMBER
	LT1613CS5
	S5 PART MARKING
	LTED

Consult factory for Industrial and Military grade parts.

ELECTRICAL CHARACTERISTICS

The ● denotes the specifications which apply over the full operating temperature range, otherwise specifications are at $T_A = 25^\circ C$. Commercial grade 0°C to 70°C, $V_{IN} = 1.5V$, $V_{SHDN} = V_{IN}$ unless otherwise noted. (Note 2)

PARAMETER	CONDITIONS	MIN	TYP	MAX	UNITS
Minimum Operating Voltage			0.9	1.1	V
Maximum Operating Voltage				10	V
Feedback Voltage		● 1.205	1.23	1.255	V
FB Pin Bias Current		●	27	80	nA
Quiescent Current	$V_{SHDN} = 1.5V$		3	4.5	mA
Quiescent Current in Shutdown	$V_{SHDN} = 0V, V_{IN} = 2V$		0.01	0.5	μA
	$V_{SHDN} = 0V, V_{IN} = 5V$		0.01	1.0	μA
Reference Line Regulation	$1.5V \leq V_{IN} \leq 10V$		0.02	0.2	%/V
Switching Frequency		● 1.0	1.4	1.8	MHz
Maximum Duty Cycle		● 82	86		%
Switch Current Limit	(Note 3)	550	800		mA
Switch V_{CESAT}	$I_{SW} = 300mA$		300	350	mV
Switch Leakage Current	$V_{SW} = 5V$		0.01	1	μA
SHDN Input Voltage High		1			V
SHDN Input Voltage Low				0.3	V
SHDN Pin Bias Current	$V_{SHDN} = 3V$		25	50	μA
	$V_{SHDN} = 0V$		0.01	0.1	μA

Note 1: Absolute Maximum Ratings are those values beyond which the life of a device may be impaired.

Note 2: The LT1613C is guaranteed to meet performance specifications from 0°C to 70°C. Specifications over the -40°C to 85°C operating temperature range are assured by design, characterization and correlation with statistical process controls.

Note 3: Current limit guaranteed by design and/or correlation to static test.

TYPICAL PERFORMANCE CHARACTERISTICS

Switch V_{CESAT} vs Switch Current

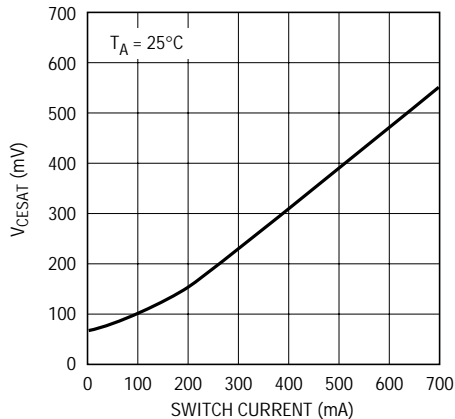

1613 G01

Oscillator Frequency vs Temperature

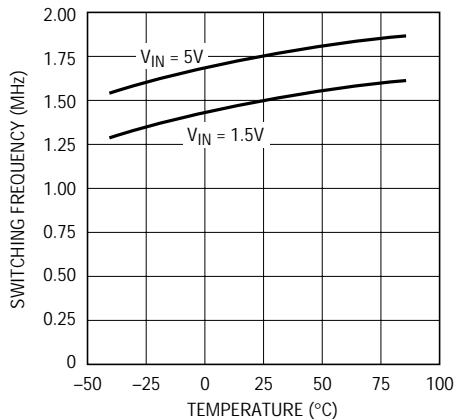

1613 G02

\overline{SHDN} Pin Current vs $V_{\overline{SHDN}}$

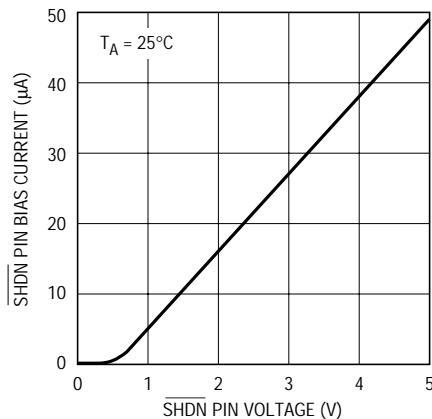

1613 G03

Current Limit vs Duty Cycle

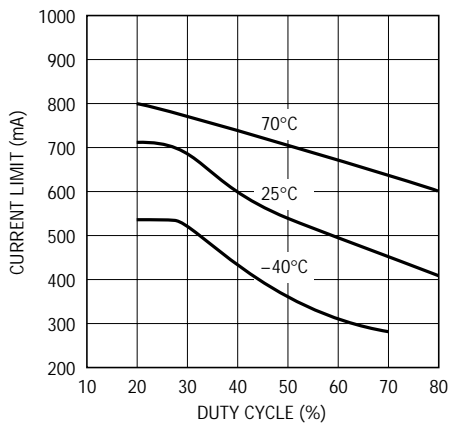

1613 G04

Feedback Pin Voltage

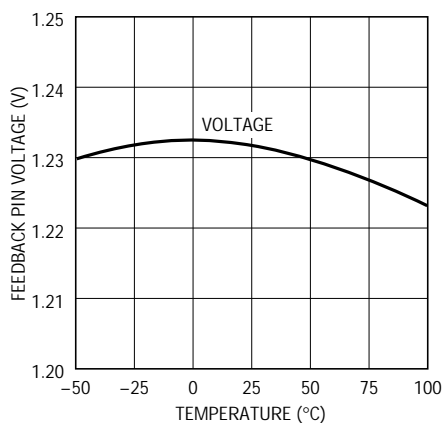

1613 G05

Switching Waveforms, Circuit of Figure 1

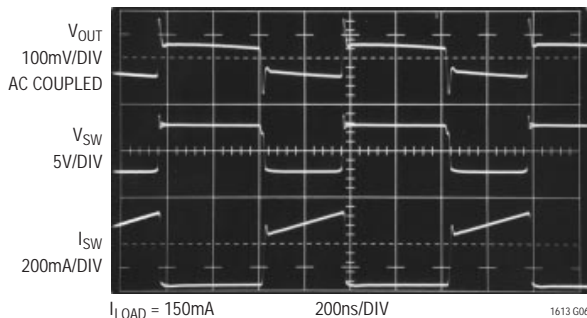

1613 G06

PIN FUNCTIONS

SW (Pin 1): Switch Pin. Connect inductor/diode here. Minimize trace area at this pin to keep EMI down.

GND (Pin 2): Ground. Tie directly to local ground plane.

FB (Pin 3): Feedback Pin. Reference voltage is 1.23V. Connect resistive divider tap here. Minimize trace area at FB. Set V_{OUT} according to $V_{OUT} = 1.23V(1 + R1/R2)$.

SHDN (Pin 4): Shutdown Pin. Tie to 1V or more to enable device. Ground to shut down.

V_{IN} (Pin 5): Input Supply Pin. Must be locally bypassed.

BLOCK DIAGRAM

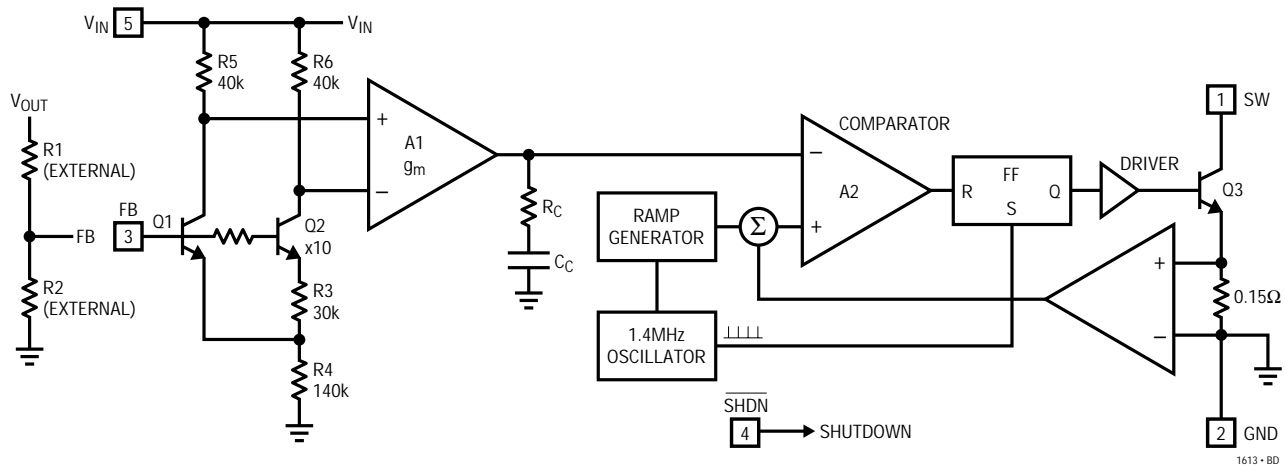

OPERATION

The LT1613 is a current mode, internally compensated, fixed frequency step-up switching regulator. Operation can be best understood by referring to the Block Diagram. Q1 and Q2 form a bandgap reference core whose loop is closed around the output of the regulator. The voltage drop across R5 and R6 is low enough such that Q1 and Q2 do not saturate, even when V_{IN} is 1V. When there is no load, FB rises slightly above 1.23V, causing V_C (the error amplifier's output) to decrease. Comparator A2's output stays high, keeping switch Q3 in the off state. As increased output loading causes the FB voltage to decrease, A1's output increases. Switch current is regulated directly on a cycle-by-cycle basis by the V_C node. The flip flop is set at the beginning of each switch cycle, turning on the switch. When the summation of a signal representing switch current and a ramp generator (introduced to avoid subharmonic oscillations at duty factors greater than

50%) exceeds the V_C signal, comparator A2 changes state, resetting the flip flop and turning off the switch. More power is delivered to the output as switch current is increased. The output voltage, attenuated by external resistor divider R1 and R2, appears at the FB pin, closing the overall loop. Frequency compensation is provided internally by R_C and C_C . Transient response can be optimized by the addition of a phase lead capacitor C_{PL} in parallel with R1 in applications where large value or low ESR output capacitors are used.

As the load current is decreased, the switch turns on for a shorter period each cycle. If the load current is further decreased, the converter will skip cycles to maintain output voltage regulation. If the FB pin voltage is increased significantly above 1.23V, the LT1613 will enter a low power state where quiescent current falls to approximately 100 μ A.

OPERATION

LAYOUT

The LT1613 switches current at high speed, mandating careful attention to layout for proper performance. *You will not get advertised performance with careless layouts.* Figure 2 shows recommended component placement for a boost (step-up) converter. Follow this closely in your PCB layout. Note the direct path of the switching loops. Input capacitor C1 *must* be placed close (< 5mm) to the IC package. As little as 10mm of wire or PC trace from C_{IN} to V_{IN} will cause problems such as inability to regulate or oscillation.

The ground terminal of output capacitor C2 should tie close to Pin 2 of the LT1613. Doing this reduces di/dt in the ground copper which keeps high frequency spikes to a minimum. The DC/DC converter ground should tie to the PC board ground plane at one place only, to avoid introducing di/dt in the ground plane.

A SEPIC (single-ended primary inductance converter) schematic is shown in Figure 3. This converter topology produces a regulated output voltage that spans (i.e., can be higher or lower than) the output. Recommended component placement for a SEPIC is shown in Figure 4.

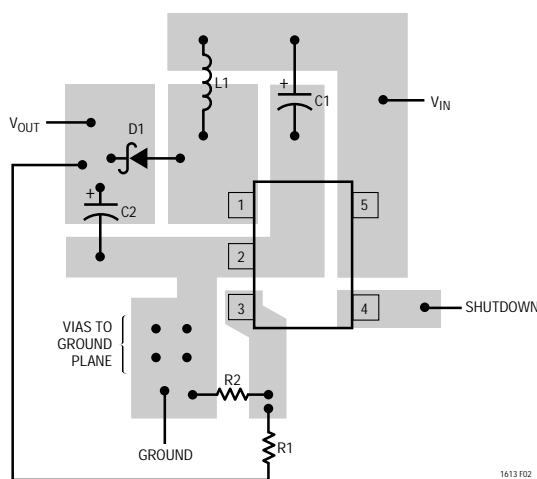

Figure 2. Recommended Component Placement for Boost Converter. Note Direct High Current Paths Using Wide PCB Traces. Minimize Area at Pin 3 (FB). Use Vias to Tie Local Ground Into System Ground Plane. Use Vias at Location Shown to Avoid Introducing Switching Currents Into Ground Plane

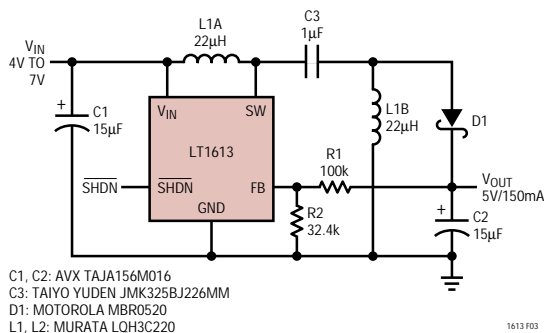

Figure 3. Single-Ended Primary Inductance Converter (SEPIC) Generates 5V from An Input Voltage Above or Below 5V

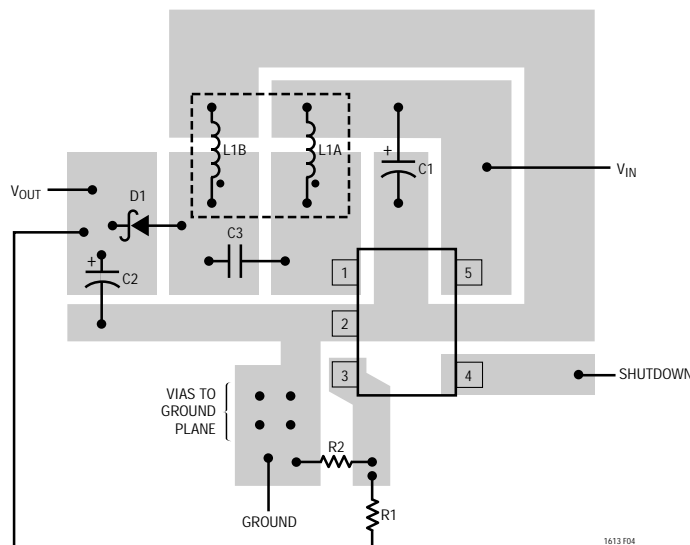

Figure 4. Recommended Component Placement for SEPIC

COMPONENT SELECTION

Inductors

Inductors used with the LT1613 should have a saturation current rating (where inductance is approximately 70% of zero current inductance) of approximately 0.5A or greater. DCR of the inductors should be 0.5Ω or less. For boost converters, inductance should be 4.7µH for input voltage less than 3.3V and 10µH for inputs above 3.3V. When using the device as a SEPIC, either a coupled inductor or two separate inductors can be used. If using separate inductors, 22µH units are recommended for input voltage above 3.3V. Coupled inductors have a beneficial mutual inductance, so a 10µH coupled inductor results in the same ripple current as two 20µH uncoupled units.

OPERATION

Table 1 lists several inductors that will work with the LT1613, although this is not an exhaustive list. There are many magnetics vendors whose components are suitable for use.

Diodes

A Schottky diode is recommended for use with the LT1613. The Motorola MBR0520 is a very good choice. Where the input to output voltage differential exceeds 20V, use the MBR0530 (a 30V diode). If cost is more important than efficiency, the 1N4148 can be used, but only at low current loads.

Capacitors

The input bypass capacitor must be placed physically close to the input pin. ESR is not critical and in most cases an inexpensive tantalum is appropriate.

The choice of output capacitor is far more important. The quality of this capacitor is the greatest determinant of the output voltage ripple. The output capacitor must have enough capacitance to satisfy the load under transient conditions and it must shunt the switched component of current coming through the diode. Output voltage ripple results when this switched current passes through the finite output impedance of the output capacitor. The capacitor should have low impedance at the 1.4MHz switching frequency of the LT1613. At this frequency, the impedance is usually dominated by the capacitor's equivalent series resistance (ESR). Choosing a capacitor with

lower ESR will result in lower output ripple.

Ceramic capacitors can be used with the LT1613 provided loop stability is considered. A tantalum capacitor has some ESR and this causes an "ESR zero" in the regulator loop. This zero is beneficial to loop stability. The internally compensated LT1613 does not have an accessible compensation node, but other circuit techniques can be employed to counteract the loss of the ESR zero, as detailed in the next section.

Some capacitor types appropriate for use with the LT1613 are listed in Table 2.

OPERATION WITH CERAMIC CAPACITORS

Because the LT1613 is internally compensated, loop stability must be carefully considered when choosing an output capacitor. Small, low cost tantalum capacitors have some ESR, which aids stability. However, ceramic capacitors are becoming more popular, having attractive characteristics such as near-zero ESR, small size and reasonable cost. Simply replacing a tantalum output capacitor with a ceramic unit will decrease the phase margin, in some cases to unacceptable levels. With the addition of a phase lead capacitor (C_{PL}) and isolating resistor (R_3), the LT1613 can be used successfully with ceramic output capacitors as described in the following figures.

A boost converter, stepping up 2.5V to 5V, is shown in Figure 5. Tantalum capacitors are used for the input and output (the input capacitor is not critical and has little

Table 1. Inductor Vendors

VENDOR	PHONE	URL	PART	COMMENT
Sumida	(847) 956-0666	www.sumida.com	CLS62-22022 CD43-220	22μH Coupled 22μH
Murata	(404) 436-1300	www.murata.com	LQH3C-220 LQH3C-100 LQH3C-4R7	22μH, 2mm Height 10μH 4.7μH
Coiltronics	(407) 241-7876	www.coiltronics.com	CTX20-1	20μH Coupled, Low DCR

Table 2. Capacitor Vendors

VENDOR	PHONE	URL	PART	COMMENT
Taiyo Yuden	(408) 573-4150	www.t-yuden.com	Ceramic Caps	X5R Dielectric
AVX	(803) 448-9411	www.avxcorp.com	Ceramic Caps Tantalum Caps	
Murata	(404) 436-1300	www.murata.com	Ceramic Caps	

OPERATION

effect on loop stability, as long as minimum capacitance requirements are met). The transient response to a load step of 50mA to 100mA is pictured in Figure 6. Note the "double trace," due to the ESR of C2. The loop is stable and settles in less than 100µs. In Figure 7, C2 is replaced by a 10µF ceramic unit. Phase margin decreases drastically,

resulting in a severely underdamped response. By adding R3 and C_{PL} as detailed in Figure 8's schematic, phase margin is restored, and transient response to the same load step is pictured in Figure 9. R3 isolates the device FB pin from fast edges on the V_{OUT} node due to parasitic PC trace inductance.

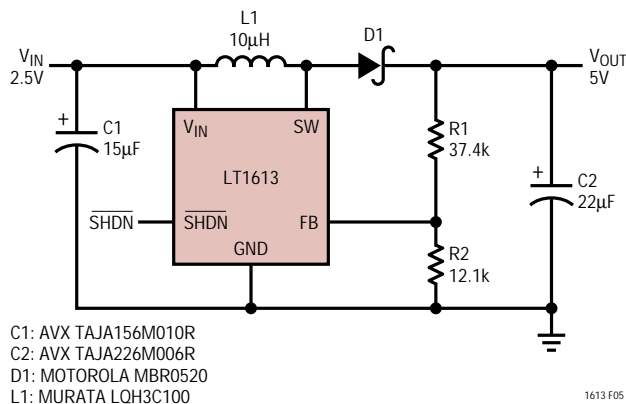

Figure 5. 2.5V to 5V Boost Converter with "A" Case Size Tantalum Input and Output Capacitors

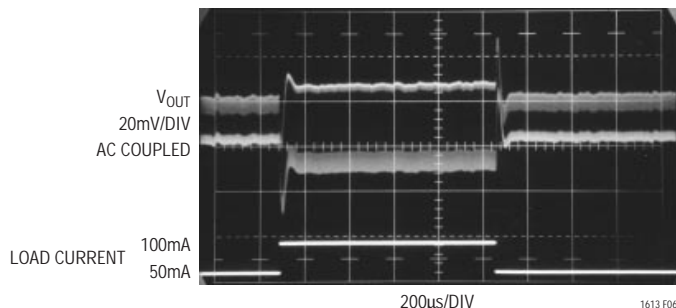

Figure 6. 2.5V to 5V Boost Converter Transient Response with 22µF Tantalum Output Capacitor. Apparent Double Trace on V_{OUT} Is Due to Switching Frequency Ripple Current Across Capacitor ESR

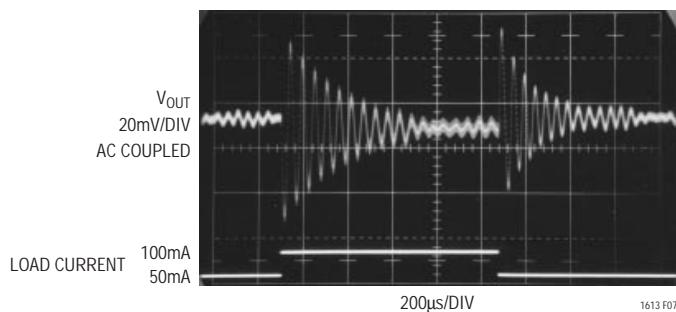

Figure 7. 2.5V to 5V Boost Converter with 10µF Ceramic Output Capacitor, No C_{PL}

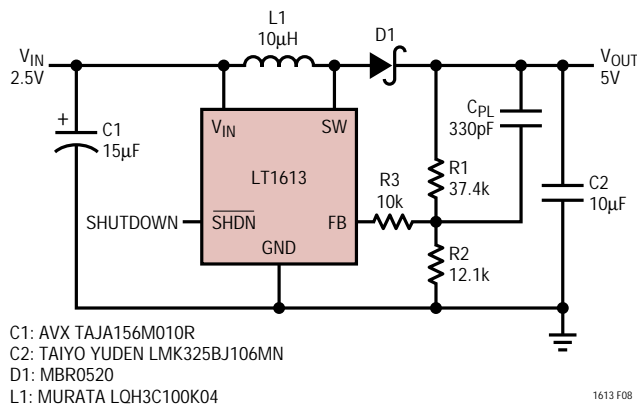

Figure 8. 2.5V to 5V Boost Converter with Ceramic Output Capacitor. C_{PL} Added to Increase Phase Margin, R3 Isolates FB Pin from Fast Edges

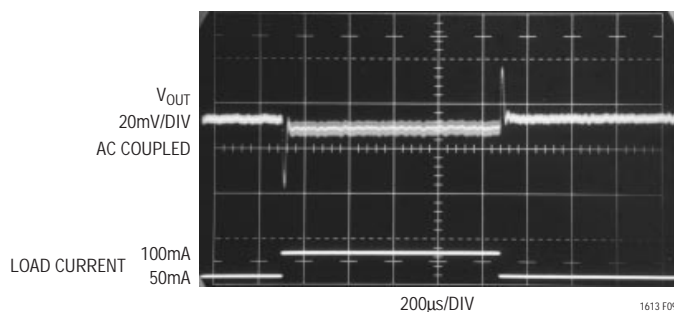
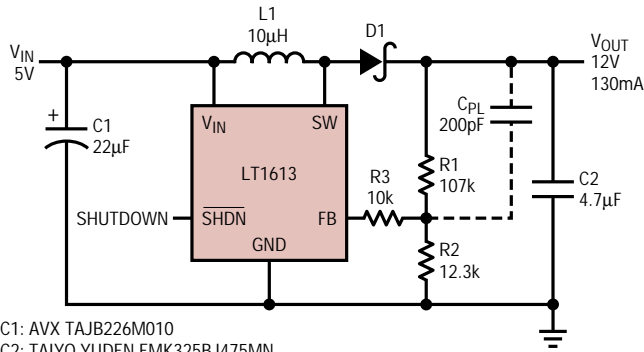

Figure 9. 2.5V to 5V Boost Converter with 10µF Ceramic Output Capacitor, 330pF C_{PL} and 10k in Series with FB Pin

OPERATION



C1: AVX TAJB226M010
 C2: TAIYO YUDEN EMK325BJ475MN
 D1: MOTOROLA MBR0520
 L1: MURATA LQH3C100

1613 F10

Figure 10. 5V to 12V Boost Converter with 4.7µF Ceramic Output Capacitor, C_{PL} Added to Increase Phase Margin

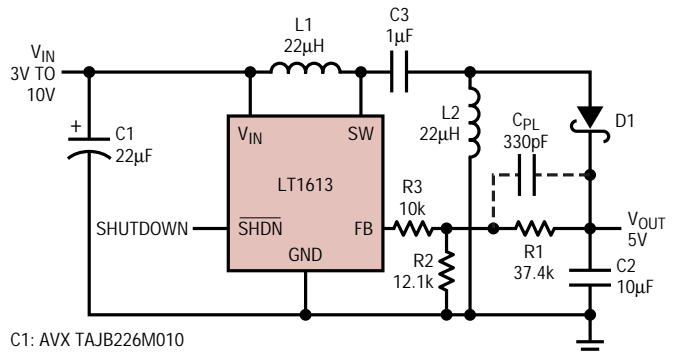

C1: AVX TAJB226M010
 C2: TAIYO YUDEN LMK325BJ106MN
 C3: TAIYO YUDEN LMK212BJ105MG
 D1: MOTOROLA MBR0520
 L1, L2: MURATA LQH3C220

1613 F13

Figure 13. 5V Output SEPIC with Ceramic Output Capacitor. C_{PL} Adds Phase Margin

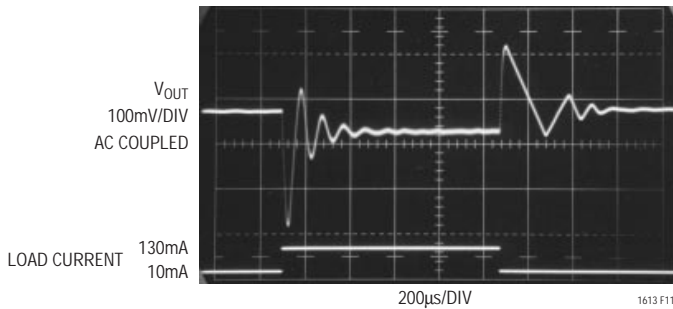

1613 F11

Figure 11. 5V to 12V Boost Converter with 4.7µF Ceramic Output Capacitor

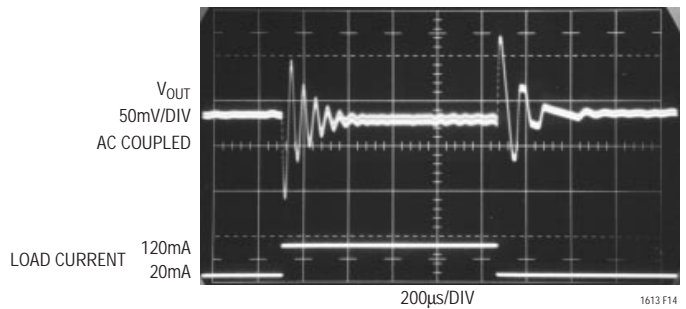

1613 F14

Figure 14. 5V Output SEPIC with 10µF Ceramic Output Capacitor. No C_{PL} . $V_{IN} = 4V$

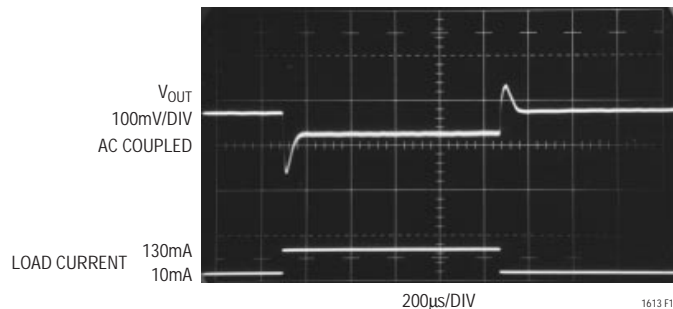

1613 F12

Figure 12. 5V to 12V Boost Converter with 4.7µF Ceramic Output Capacitor and 200pF Phase-Lead Capacitor C_{PL} and 10k in Series with FB Pin

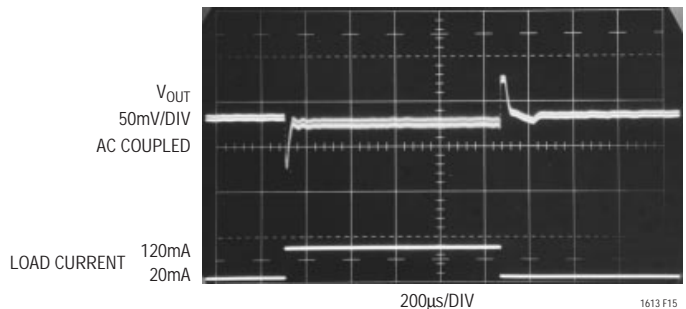

1613 F15

Figure 15. 5V Output SEPIC with 10µF Ceramic Output Capacitor, 330pF C_{PL} and 10k in Series with FB Pin

OPERATION

START-UP/SOFT-START

When the LT1613 $\overline{\text{SHDN}}$ pin voltage goes high, the device rapidly increases the switch current until internal current limit is reached. Input current stays at this level until the output capacitor is charged to final output voltage. Switch current can exceed 1A. Figure 16's oscillograph details start-up waveforms of Figure 17's SEPIC into a 50Ω load without any soft-start. The output voltage reaches final value in approximately $200\mu\text{s}$, while input current reaches 400mA. Switch current in a SEPIC is 2x the input current, so the switch is conducting approximately 800mA peak.

Soft-start reduces the inrush current by taking more time to reach final output voltage. A soft-start circuit consisting of Q1, R_{S1} , R_{S2} and C_{S1} as shown in Figure 17 can be used to limit inrush current to a lower value. Figure 18 pictures V_{OUT} and input current with R_{S2} of $33k\Omega$ and C_S of 10nF . Input current is limited to a peak value of 200mA as the

time required to reach final value increases to 1.7ms. In Figure 19, C_S is increased to 33nF . Input current does not exceed the steady-state current the device uses to supply power to the 50Ω load. Start-up time increases to 4.3ms. C_S can be increased further for an even slower ramp, if desired.

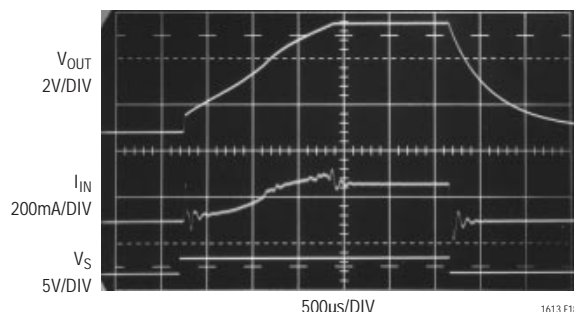

Figure 18. Soft-Start Components in Figure 17's SEPIC Reduces Inrush Current. $C_{SS} = 10\text{nF}$, $R_{\text{LOAD}} = 50\Omega$

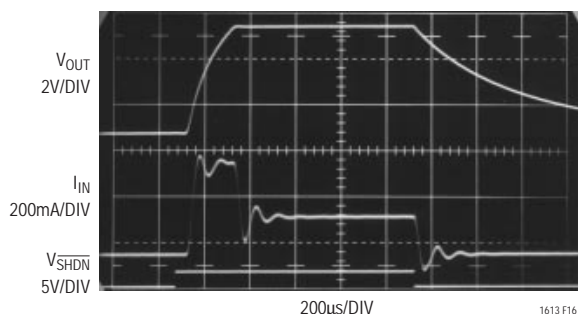

Figure 16. Start-Up Waveforms of Figure 17's SEPIC Into 50Ω Load

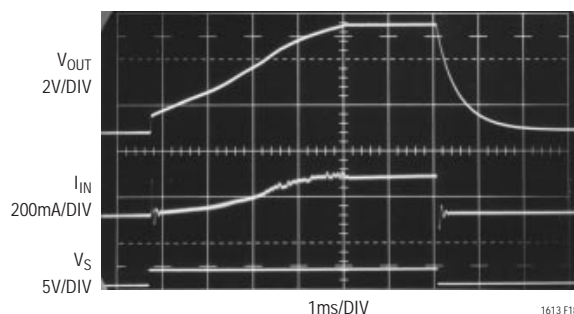

Figure 19. Increasing C_S to 33nF Further Reduces Inrush Current. $R_{\text{LOAD}} = 50\Omega$

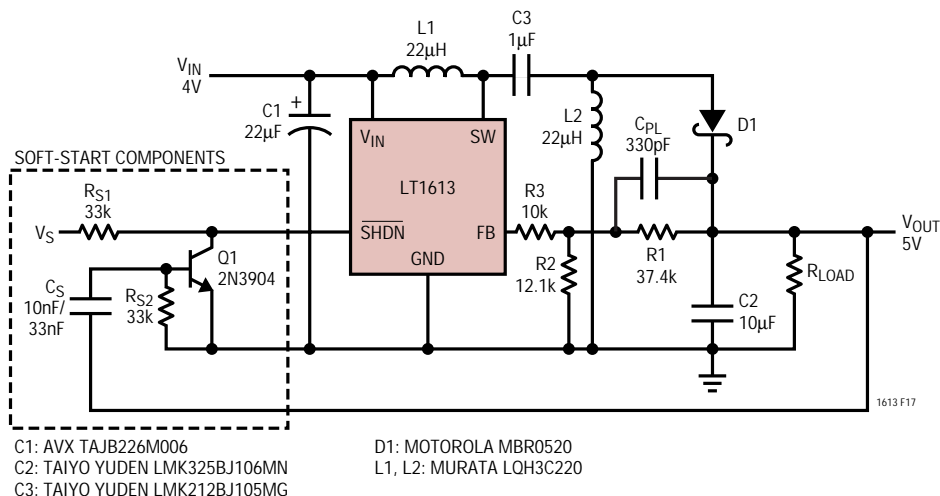
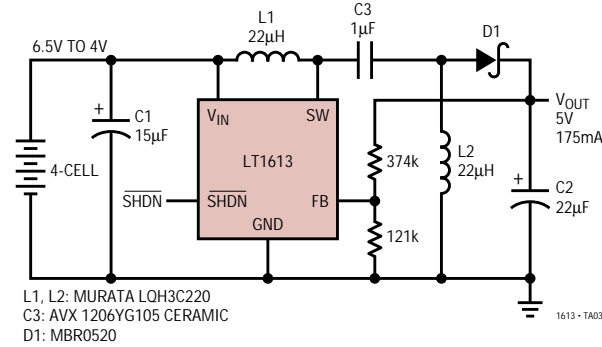

Figure 17. 5V SEPIC with Soft-Start Components

TYPICAL APPLICATIONS

4-Cell to 5V SEPIC DC/DC Converter



4-Cell to 15V/30mA DC/DC Converter

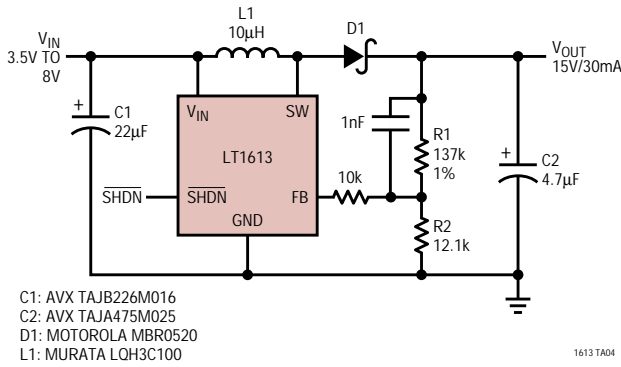

Efficiency

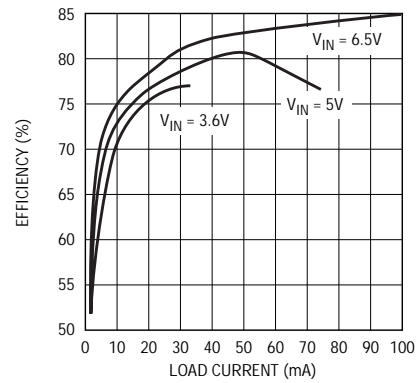

3.3V to 8V/70mA, -8V/5mA, 24V/5mA TFT LCD Bias Supply Uses All Ceramic Capacitors

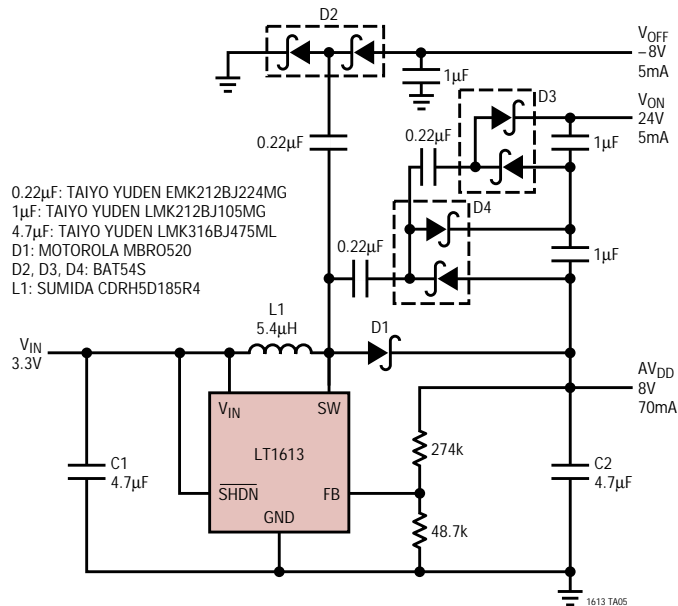

TYPICAL APPLICATIONS

4-Cell to 5V/50mA, 12V/10mA, 15V/10mA Digital Camera Power Supply

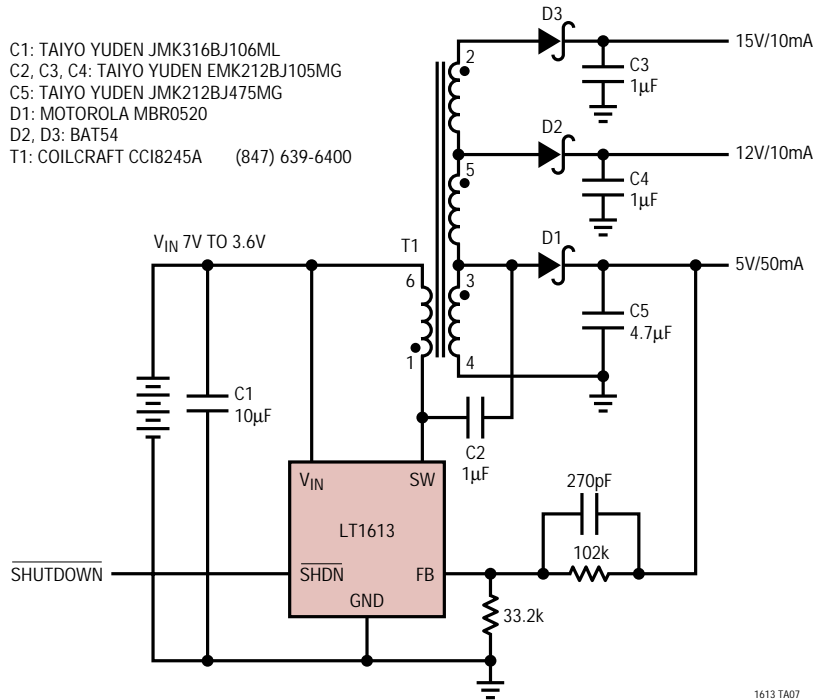

4-Cell to 5V/50mA, 15V/10mA, -7.5V/10mA Digital Camera Power Supply

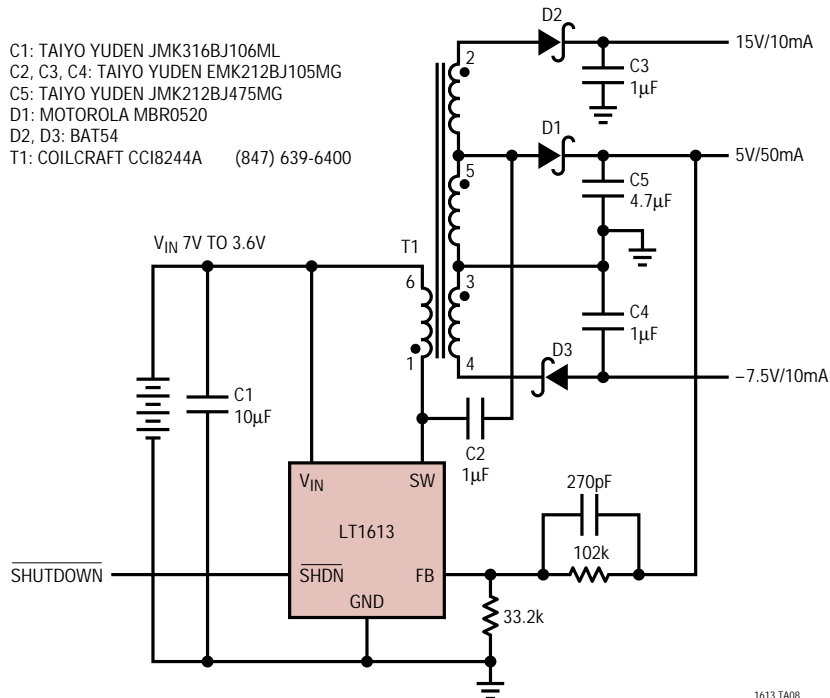

TYPICAL APPLICATIONS

Li-Ion to 16V/20mA Step-Up DC/DC Converter

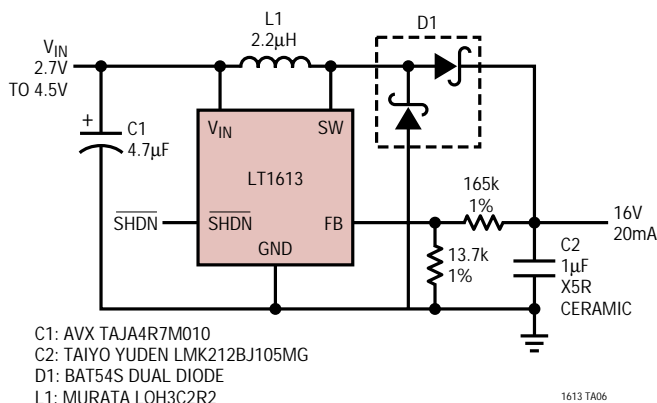

PACKAGE DESCRIPTION Dimensions in inches (millimeters) unless otherwise noted.

S5 Package 5-Lead Plastic SOT-23 (LTC DWG # 05-08-1633)

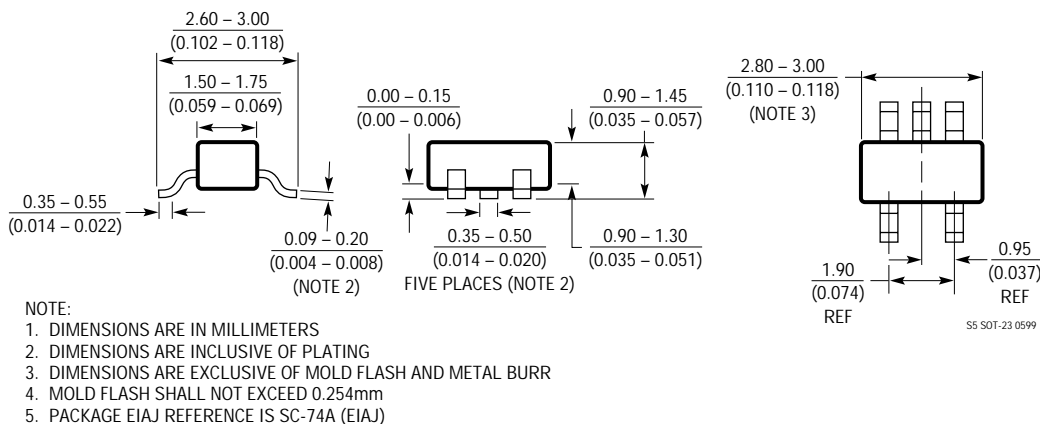

RELATED PARTS

PART NUMBER	DESCRIPTION	COMMENTS
LT1307	Single Cell Micropower DC/DC	3.3V/75mA From 1V; 600kHz Fixed Frequency
LT1317	2-Cell Micropower DC/DC	3.3V/200mA From Two Cells; 600kHz Fixed Frequency
LTC1474	Low Quiescent Current, High Efficiency Step-Down Converter	94% Efficiency, 10µA I _Q , 9V to 5V at 250µA
LT1521	300mA Low Dropout Regulator with Micropower Quiescent Current and Shutdown	500mV Dropout, 300mA Output Current, 12µA I _Q
LTC1517-5	Micropower, Regulated Charge Pump	3-Cells to 5V at 20mA, SOT-23 Package, 6µA I _Q
LT1610	1.7MHz Single Cell Micropower DC/DC Converter	30µA I _Q , MSOP Package, Internal Compensation
LT1611	Inverting 1.4MHz Switching Regulator	5V to -5V at 150mA, Low Output Noise
LT1615/LT1615-1	Micropower DC/DC Converter in 5-Lead SOT-23	20V at 12mA from 2.5V Input, Tiny SOT-23 Package